

JOINT CONNECTOR NUT ¼" X 17mm

JOINT CONNECTOR BOLT ¼" X 35mm

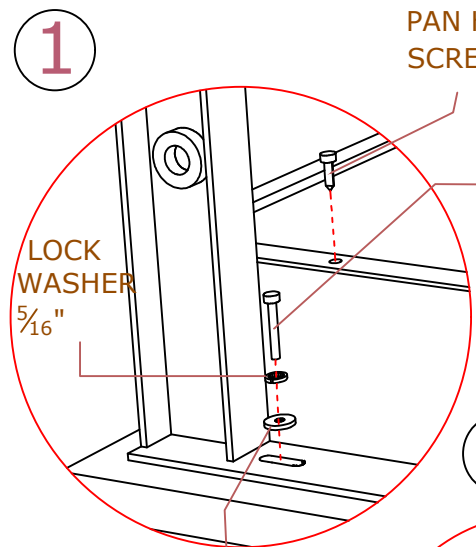

LOCK WASHER 5/16"

PLAIN WASHER 5/16"

PAN HEAD SCREW 6 X 3/4"

BUTTON HEAD SOCKET BOLT 5/16" X 1"

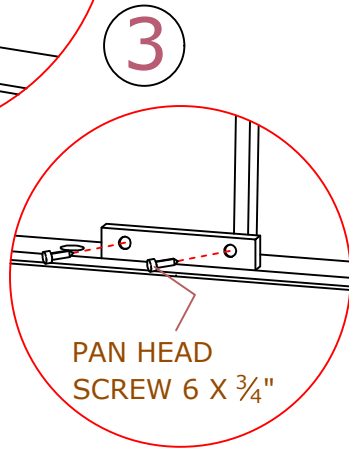

PAN HEAD SCREW 6 X 3/4"

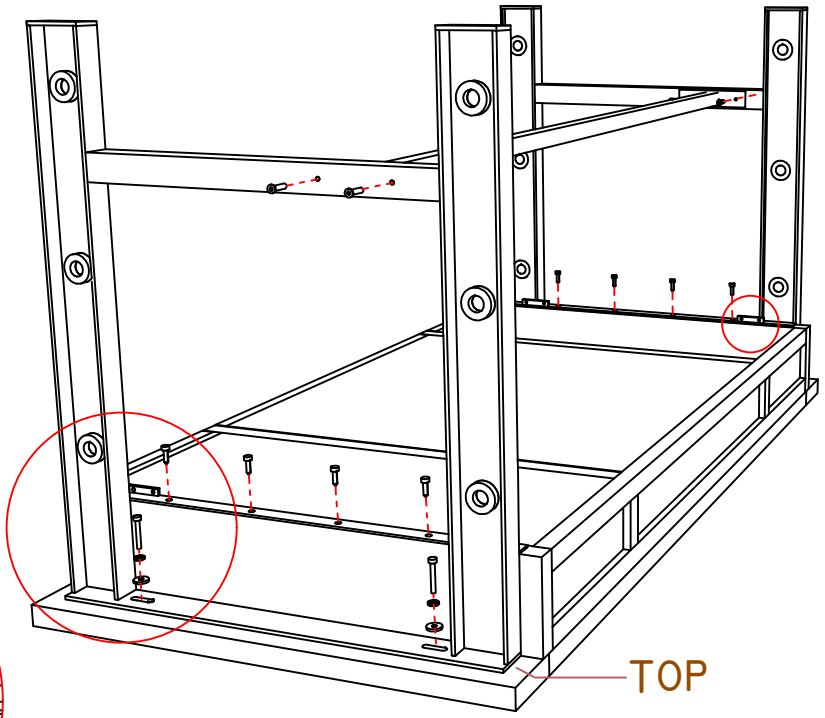

TOP

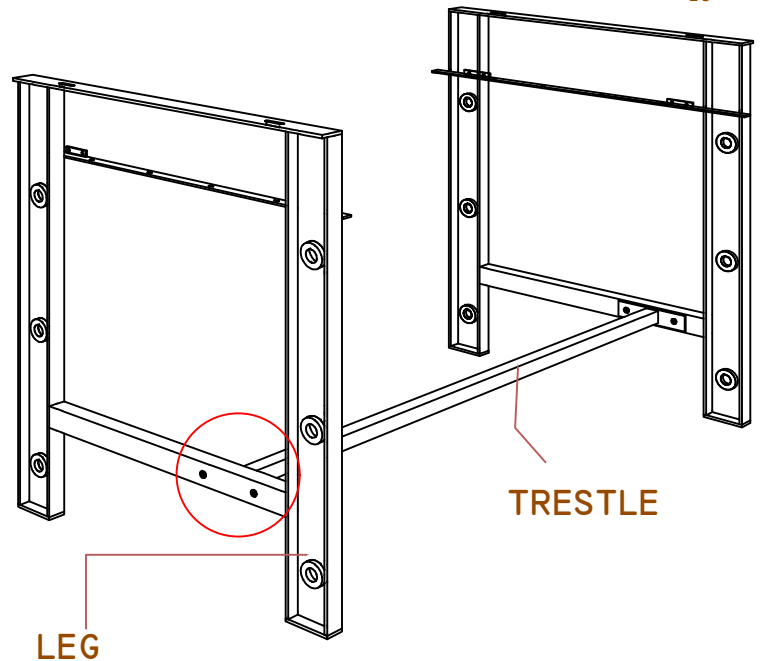

TRESTLE

LEG

| DESCRIPTION | #PZ |
|------------------------------------|-----|
| Join Connector Nut ¼" x 17mm | 4 |
| Join Connector Bolt ¼" x 35mm | 4 |
| Lock Washer 5/16" | 4 |
| Plain Washer 5/16" | 4 |
| Pan Head Screw 6 x 3/4" | 16 |
| Button Head Socket Bolt 5/16" x 1" | 4 |
| Allen Key 5/32" | 2 |
| Allen Key 3/16" | 1 |

INSTRUCTIONS

- 1.- WITH SOMEONE ELSE'S HELP, PLACE THE DESK UPSIDE DOWN. ON A FLAT AND CLEAN SURFACE.
- 2.- HOLD THE LEGS ALIGNED WITH THE HOLES ON THE TOP AND ATTACH THEM LOOSELY TO IT AS SHOWN IN FIG.1.
- 3.- ATTACH THE CROSSBAR BETWEEN THE LEGS WITH THE JOINT CONNECTOR NUTS AND BOLTS. FIG.2.
- 4.- IF ALL THE PARTS ARE ALIGNED IN THEIR CORRECT POSITION, START TIGHTENING ALL THE BOLTS AND INSERT THE SCREWS AS SHOWN IN FIG. 2 AND 3.

ASSEMBLY INSTRUCTIONS