

ASSEMBLY INSTRUCTION / INSTRUCTION D'ASSEMBLAGE

SIDE CHAIR / CHAISE DROITE

Thank you for purchasing this quality product. Be sure to check all packing material carefully for small parts which may have come loose inside the carton during shipment. Identify and count all parts and compare with the Parts List below.





** Assemble the chair on a flat & soft surface. Do not tighten all the screw until the chair has been put a flat/hard surface adjust & level all the legs so that they do not wobble. Once adjusted then tighten all the screws.





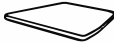

! For items use on wooden floor, hard surface or carpets, it is recommended to install protective pads under all legs and supports to avoid/prevent from damages/scratches and discoloration.

Merci d'avoir acheté ce produit de qualité. assurez-vous de vérifier les matériaux d'emballage pour les petites pièces qui s'écarte dans le carton durant le transport.

** Assembler la chaise sur une surface douce et plate pur prévenir des égratignures sur la finition. Lire tout les instructions étudié les dessins avant de commencer le montage.

! Pour les articles utilisés sur un plancher en bois, des surfaces dures ou tapis, il est recommandé d'installer des mordaches de protection sous tous les jambes et prend en charge pour éviter/empêcher de dommages/rayures et la décoloration.

PART LIST / LISTE DE PIÈCES		
NO	DESCRIPTION	QTY
1	CHAIR BACK DOSSIER 	1
2	SEAT FRAME CADRE DE SIÈGE 	1
3	WOODEN SEAT SIÈGE 	1
4	LEG PIED 	2

HARDWARE LIST / LISTE DE QUINCAILLERIE		
NO	DESCRIPTION	QTY
A	BOLT / BOULON M6 X 70MM 	4
B	BOLT / BOULON M6 X 60MM 	4
C	BOLT / BOULON M6 X 40MM 	2
D	LOCK WASHER / RONDELLE D'ARRET Ø1/4" X 12MM X 1.5MM 	10
E	FLAT WASHER / RONDELLE PLATE Ø1/4" X 16 X 1.2MM 	10
F	SCREW / VIS (RATTAN) #8 X 1" 	6
G	ALLEN KEY / CLE'ALLEN M4 X 60MM 	1

Step 1 / Etape 1.

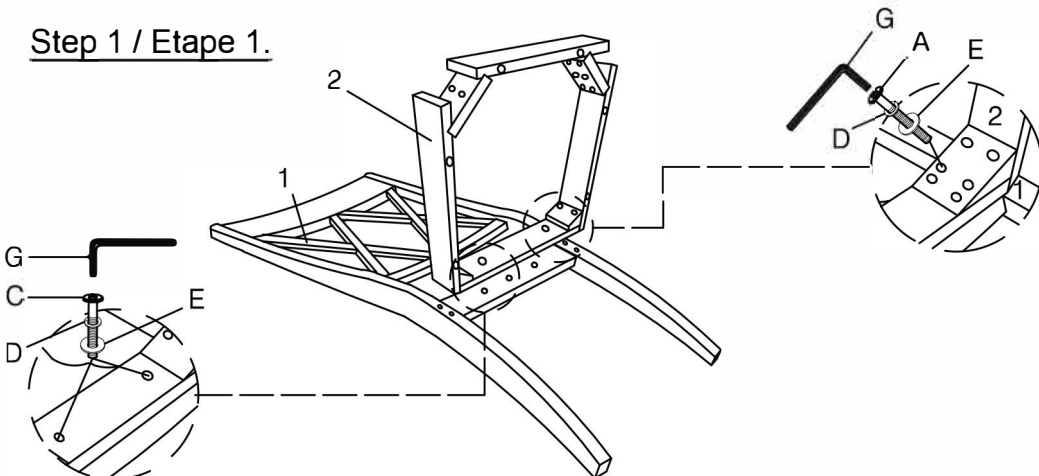

Step 2 / Etape 2.

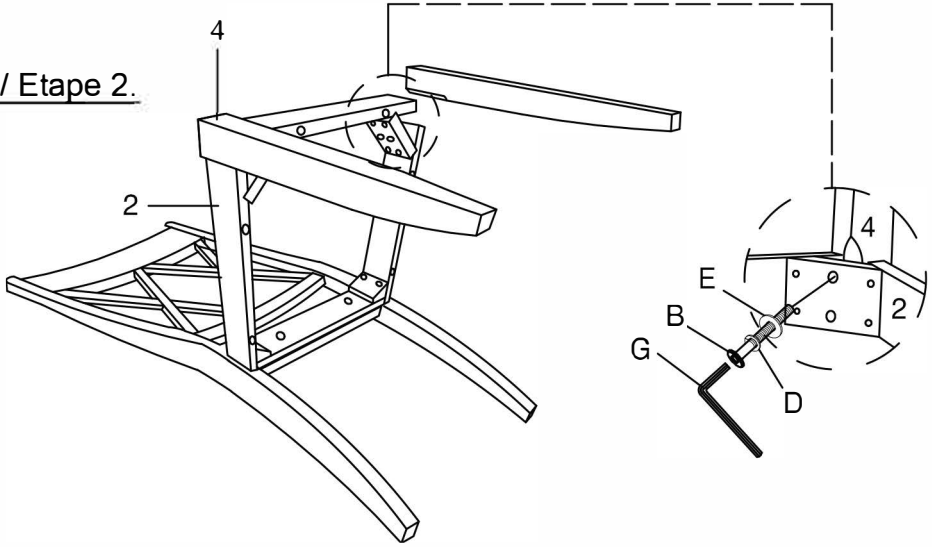

Step 3 / Etape 3.

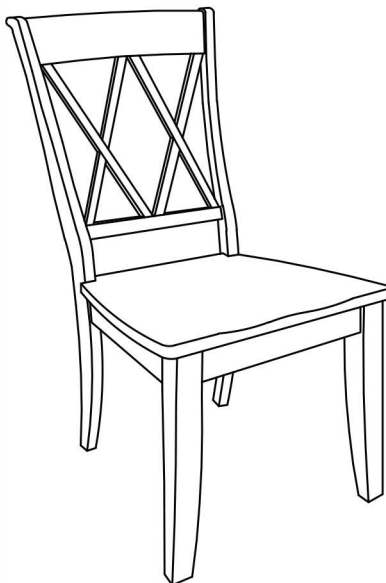
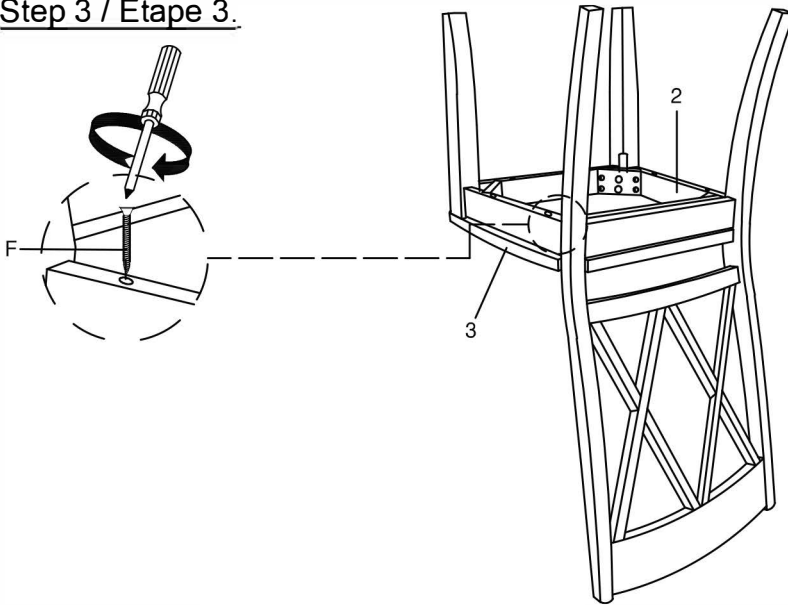

Completed