

54"

ceiling fan



Includes our new
CoolTouch™ Control System

U.S. Patent Pending



Instruction Manual

1. SAFETY RULES

1. To reduce the risk of electric shock, insure electricity has been turned off at the circuit breaker or fuse box before beginning.
2. All wiring must be in accordance with the National Electrical Code and local electrical codes. Electrical installation should be performed by a qualified licensed electrician.
3. **WARNING:** Suitable for use with solid-state speed controls.
4. **WARNING:** To reduce the risk of personal injury, use only the two steel screws (and lock washers) provided with the outlet box for mounting to the outlet box. Most outlet boxes commonly used for the support of lighting fixtures are not acceptable for fan support and may need to be replaced, consult a qualified electrician if in doubt.
5. The outlet box and support structure must be securely mounted and capable of reliably supporting a minimum of 50 pounds. Use only ETL Listed outlet boxes marked "FOR FAN SUPPORT".
6. The fan must be mounted with a minimum of 7 feet clearance from the trailing edge of the blades to the floor.
7. To operate the reverse function on this fan, press the reverse button while the fan is running.
8. Avoid placing objects in the path of the blades.
9. To avoid personal injury or damage to the fan and other items, be cautious when working around or cleaning the fan.
10. Do not use water or detergents when cleaning the fan or fan blades. A dry dust cloth or lightly dampened cloth will be suitable for most cleaning.
11. After making the electrical connections, spliced conductors should be turned upward and pushed carefully up into outlet box. The wires should be spread apart with the ground wire and white (common) wire to one side with the black (load) wire to the other side of the outlet box.
12. Electrical diagrams are reference only. Light kits that are not packed with the fan must be ETL Listed and marked suitable for use with the model fan you are installing. Switches must be ETL General Use Switches. Refer to the Instructions packaged with the light kits and switches for proper assembly.

WARNING

TO REDUCE THE RISK OF FIRE, ELECTRIC SHOCK OR PERSONAL INJURY, MOUNT FAN TO OUTLET BOX MARKED "ACCEPTABLE FOR FAN SUPPORT".

WARNING

TO REDUCE THE RISK OF PERSONAL INJURY, DO NOT BEND THE BLADE BRACKETS (ALSO REFERRED TO AS FLANGES) DURING ASSEMBLY OR AFTER INSTALLATION. DO NOT INSERT OBJECTS IN THE PATH OF THE BLADES.

2. TOOLS AND MATERIALS REQUIRED

- Philips screw driver
- Blade screw driver
- 11 mm wrench
- Step ladder
- Wire cutters

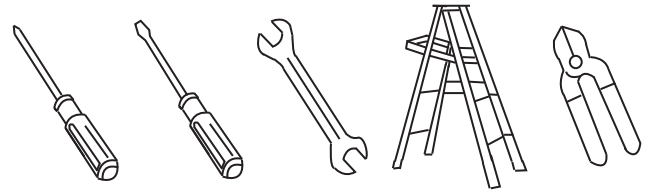

3. PACKAGE CONTENTS

Unpack your fan and check the contents. You should have the following items:

- Fan blades (2)
- Fan motor assembly
- CoolTouch™ Control System
- Part bag contents
 - Mounting hardware :
wood screws (2), flat washers (2),
star washers (2), wire nuts (3),
screws (2)
 - Blade attachment hardware:
screws (8), fiber washers (8)
 - Safety cable hardware:
wood screw, lock washer, flat washer
 - Balance Kit

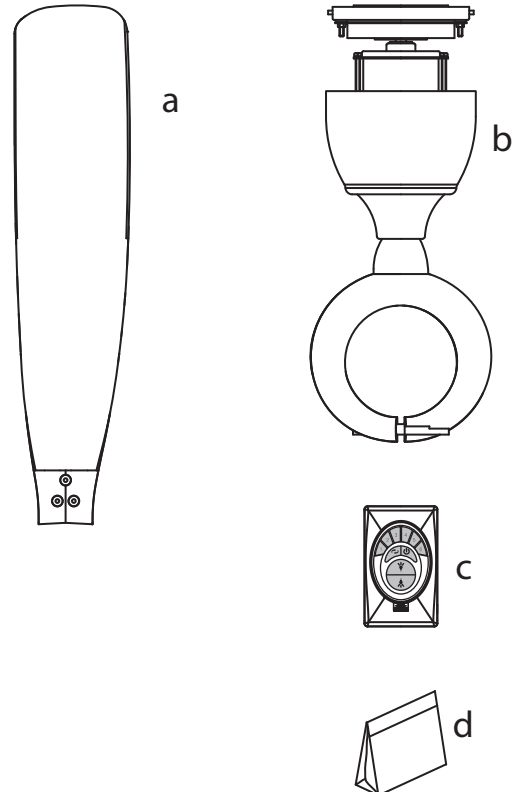

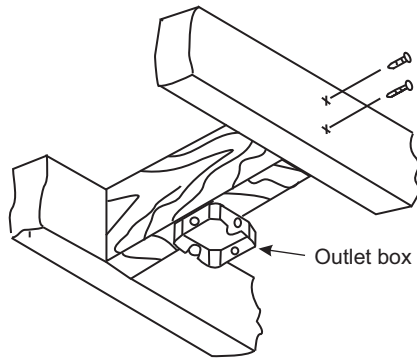

Fig. 1

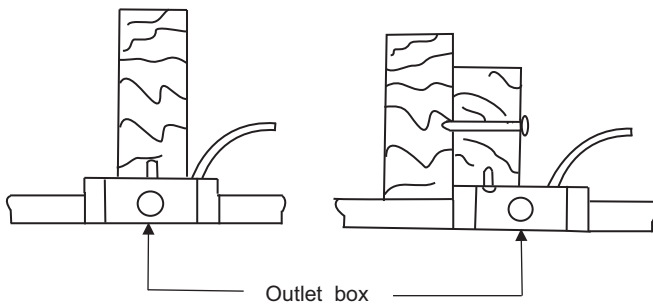

Fig. 2

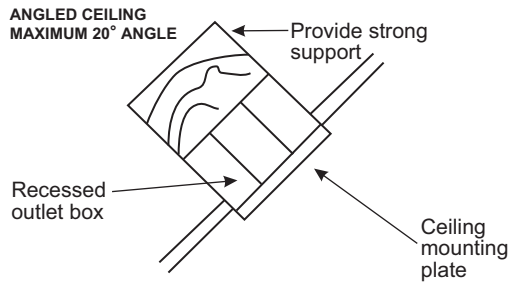

Fig. 3

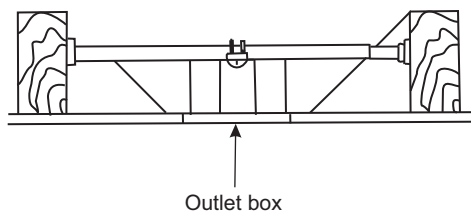

Fig. 4

4. MOUNTING OPTIONS

If there isn't an existing ETL listed mounting box, then read the following instructions. Disconnect the power by removing fuses or turning off circuit breakers.

Secure the outlet box directly to the building structure. Use appropriate fasteners and building materials. The outlet box and its support must be able to fully support the moving weight of the fan (at least 50 lbs). Do not use plastic outlet boxes.

Figures 1, 2 and 3 are examples of different ways to mount the outlet box.

NOTE: If you are installing the ceiling fan on a sloped (vaulted) ceiling, you may need a longer downrod to maintain proper clearance between the tip of the blade and the ceiling. A minimum clearance of 12" is suggested for optimal operation.

NOTE: Depending on the location you have selected for installation, you may need to purchase and install a "Joist Hanger" for the support of the outlet box. Make sure the joist hanger you purchase has been designed for use with ceiling fans. (Fig. 4)

5. REMOVE THE MOUNTING PLATE

REMEMBER to turn off the power. Follow the steps below to hang your fan properly:

Step 1. Remove the mounting plate from the fan motor by removing the nuts. (Fig. 4)

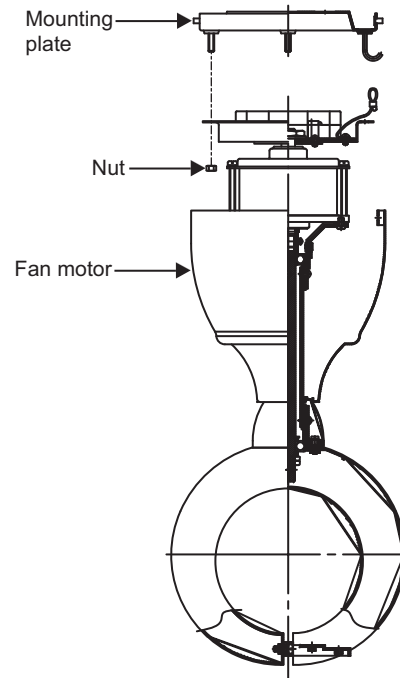

Fig. 4

6. HANGING THE FAN

REMEMBER to turn off the power. Follow the steps below to hang your fan properly:

Step 1. Attach the mounting plate to the outlet box with the screws and washers provided with the outlet box. Make sure the mounting plate is tight and secured. (Fig. 5)

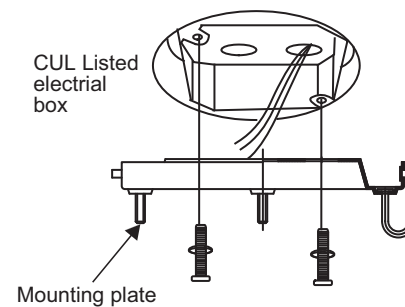

Fig. 5

Step 2. Hang the fan motor assembly and use the safety cable attached to the mounting plate. This will allow you to use both hands while make the electrical connections. (Fig. 6)

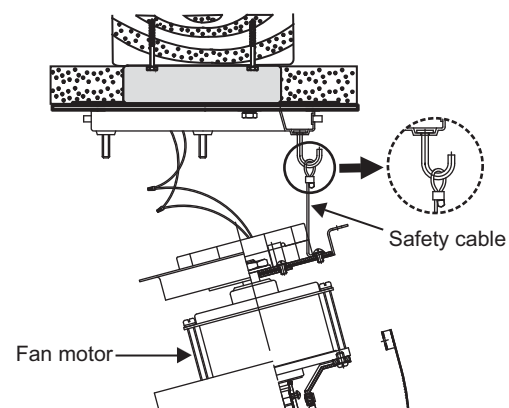

Fig. 6

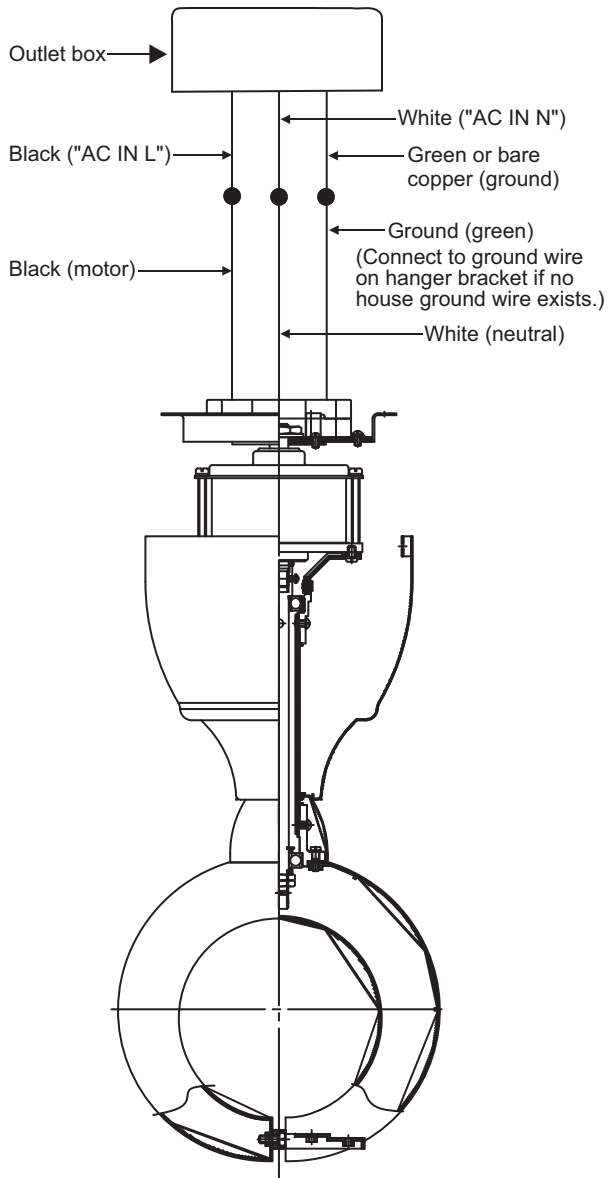

Fig. 7

7. ELECTRICAL CONNECTIONS

WARNING: To avoid possible electrical shock, be sure you have turned off the power at the main circuit panel.

Follow the steps below to connect the fan to your household wiring. Use the wire connecting nuts supplied with your fan. Secure the connectors with electrical tape. Make sure there are no loose wire strands or connections.

Step 1. Connect the fan supply (black) wire to the black household supply wire as shown in Figure 12.

Step 2. Connect the neutral fan (white) wire to the neutral household (white) wire.

Step 3. Connect the fan ground wire (green) to the household ground wire.

Step 4. After connecting the wires, spread them apart so that the green and white wires are on one side of the outlet box and the black and blue wires are on the other side.

Step 5. Turn the connecting nuts upward and push the wiring into the outlet box.

8. FINISHING THE INSTALLATION

Step 1. Move fan into position over the four mounting studs and secure with the provided nuts. (Fig. 8)

Step 2. Raise the motor housing up against the mounting plate, the four supports inside the housing should be placed against the four studs on mounting plate, twist the housing clockwise until snug. (Fig. 9)

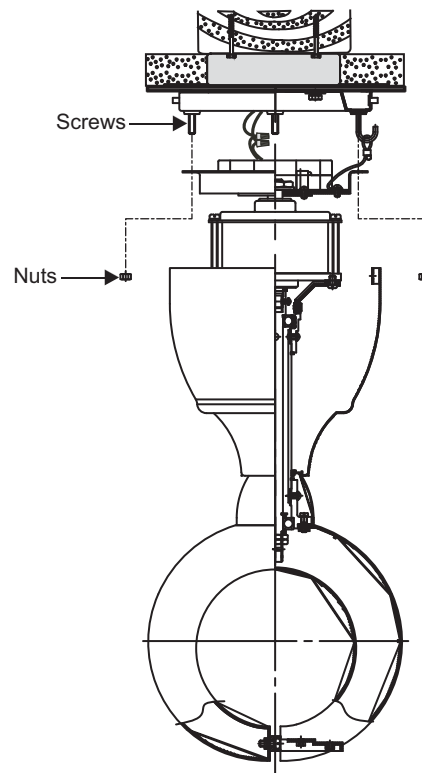

Fig. 8

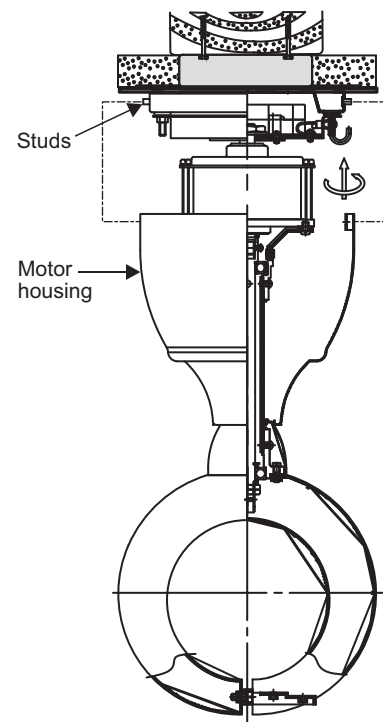

Fig. 9

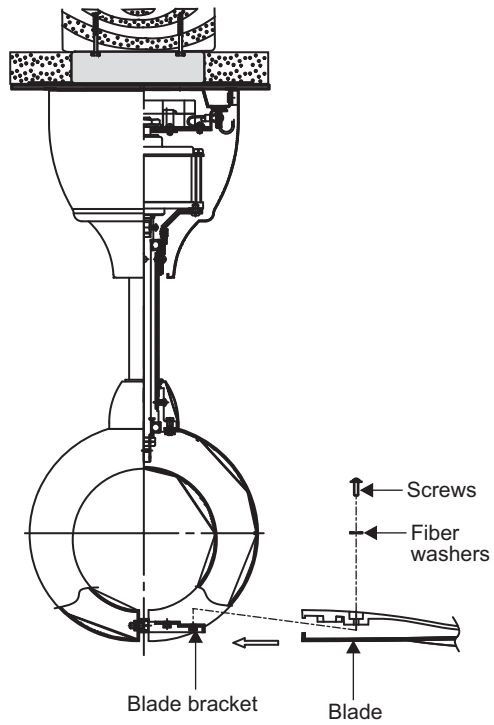

Fig. 10

9. ATTACHING THE FAN BLADES

Step 1. Attach a blade to a blade bracket using the screws and fiber washers provided. (Fig. 10)

Make sure the blade is straight when set on the blade bracket. Tighten each mounting screw and then repeat this procedure for each blade.

10. CONTROL SYSTEM SET-UP

Make sure the power is completely disconnected before you begin this procedure.

SPECIAL NOTE:

Your new Ceiling Fan is State of the Art and employs a High Efficiency DC (direct current) Motor with an advanced CoolTouch™ Remote Control System. The DC Motor uses 70% less energy than a conventional ceiling fan AC Induction Motor. The DC motor is "Digitally" controlled and operates differently than conventional ceiling fans motors. Please read this portion of the manual completely before proceeding.

Our CoolTouch™ Control system includes an "Automatic Frequency Selection" feature. To set the control frequency and program the control system, follow these steps.

Open the back of the Transmitter (figure 11)

The Frequency Selector is a "Dip Switch Block" inside the Battery compartment of the Transmitter. (See figure 12) You change frequencies by arranging the small switches numbered 1 through 4 in a up or down position. 16 possible frequencies or combinations are possible.

The fifth switch, marked D and X sets the system for operation with Incandescent or Fluorescent Lamps. It is essential to set this switch correctly. If your ceiling fan is equipped with **Incandescent Lamps** set this switch to the **D Position**, for **Fluorescent Lamps**, set the switch to the **X Position**. If these settings are reversed, the lighting control system will operate erratically and could damage your ceiling fan.

System Programing: Read all of these steps BEFORE proceeding. Each step must be followed exactly to properly program the control system.

1. You can leave the frequency switches at the factory setting or move them to any combination of up or down. Use a small flat bladed screwdriver to move the switches.

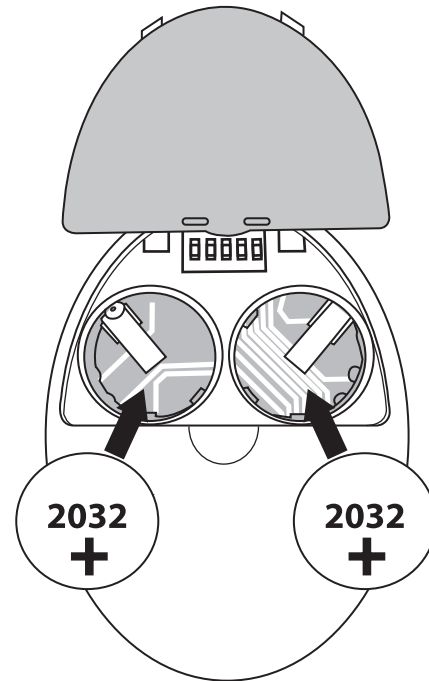

Fig. 11

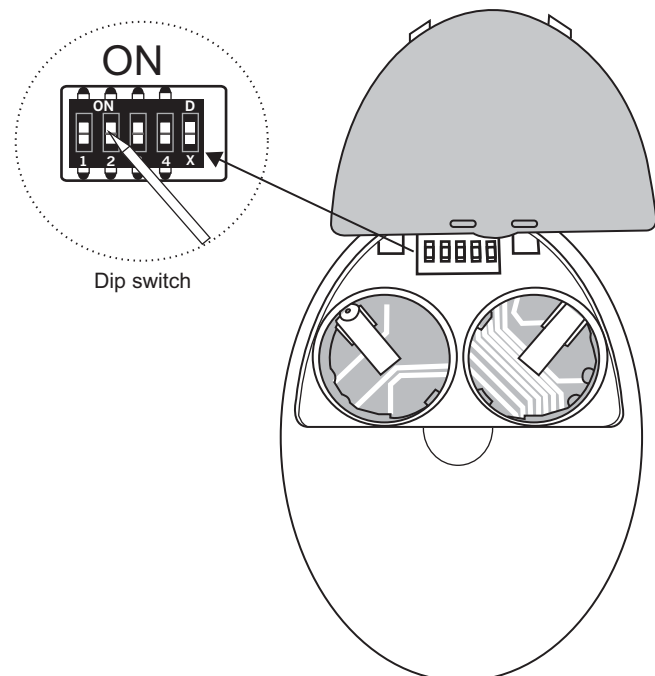

Fig. 12

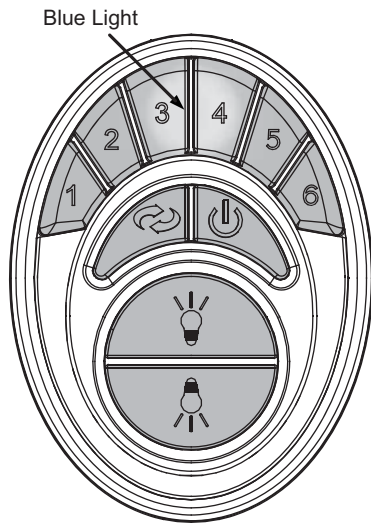

Fig. 13

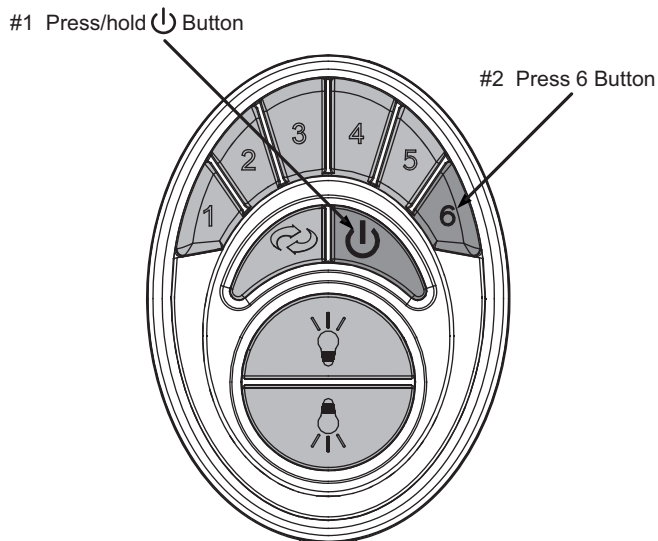

Fig. 14

2. Insert both batteries and make sure they are seated correctly in each recess with the Positive + sign facing up. Replace the battery cover. (Figure 11)

3. Test the transmitter by pushing and releasing ANY button briefly. A Blue Light should illuminate under the 3-4 buttons. (Fig. 13) If not, check to make sure the batteries are inserted and seated correctly.

Power Up and Programming:

4. Turn the power on, press and hold the (⏻) button until the ceiling fan light blinks twice (Figure 14)

NOTE: *Do not* press any other button during this procedure.

5. The transmitter just communicated with the ceiling fan, selected the appropriate frequency, did a self check and signaled “complete”.

NOTE: *This operation must be started WITHIN the first 120 seconds (2 minutes) of turning the power on. No other buttons can be push during this time.*

6. After the ceiling fan light blinks twice, press and release the High Speed (6) Button. Let the ceiling fan run for a minimum of 90 seconds (1 ½ minutes). The control system will do another self check, initialize all operational functions and complete the programming process (Figure 14).

7. Your CoolTouch™ Control System is now programmed and ready for use. Please see the follow Operational Instructions.

11. OPERATING INSTRUCTIONS:

Figure 15

1. Buttons 1, 2, 3, 4, 5 and 6 are used to set the blade speed as follows:

- 1 = Low Speed
- 2 = Medium Low Speed
- 3 = Medium Speed
- 4 = Medium High Speed
- 5 = High Speed
- 6 = Extra High Speed

Figure 16

2. The "⏻" button:
This button turns the fan motor off and is also used in the program procedure.

3. The "💡" and "💡" button:
The "💡" button turns the upper light ON or OFF and also controls the brightness setting on some models. The "💡" button turns the bottom light ON or OFF and also controls the brightness setting.

Press and hold either button to set the desired brightness level. The next time you turn the light on, the system will remember this setting.

Press and release either button to turn the light ON or OFF.

Figure 17

4. The "↻" button is used to set the fan in forward or reverse operation. Each time you press this button the fan blades will reverse direction. This button functions ONLY when the fan blades are in motion.

OPERATIONAL NOTE: Each time you start the blades rotating, at any speed or reverse the direction of the blades the Control System will do a "Self Check" to insure operational integrity. The blades will rotate slowly a short distance (¼ turn), pause, change directions, rotate ¼ turn, then build up RPM'S to the selected speed. This is a perfectly normal procedure and insures normal operating performance.

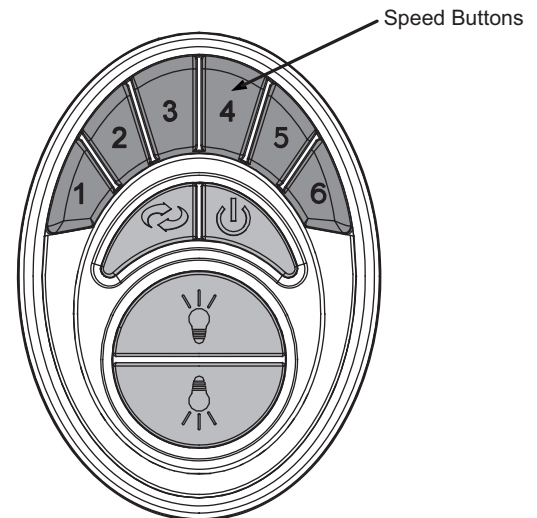

Fig. 15

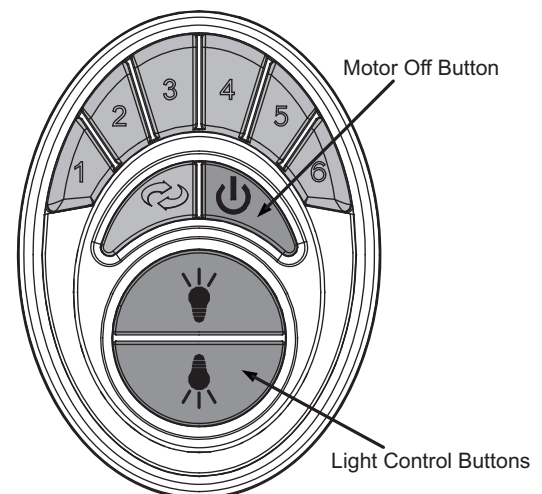

Fig. 16

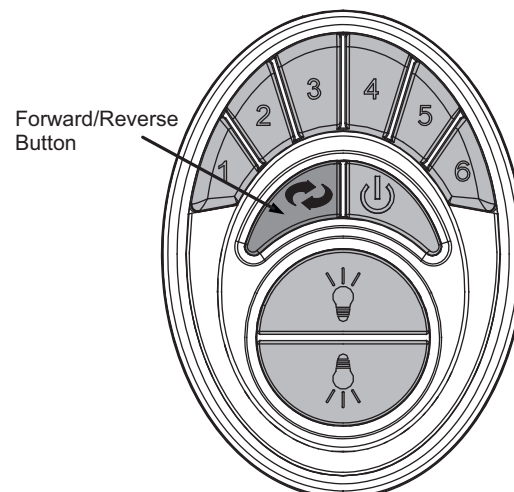

Fig. 17

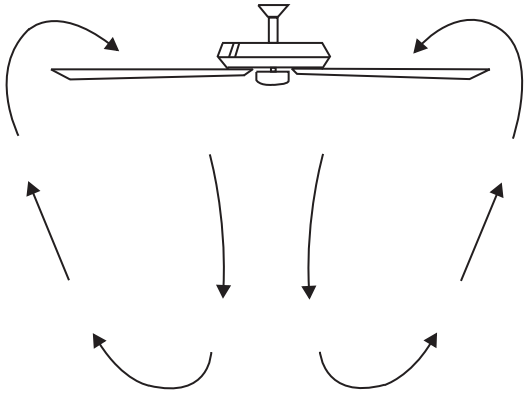

Fig. 18

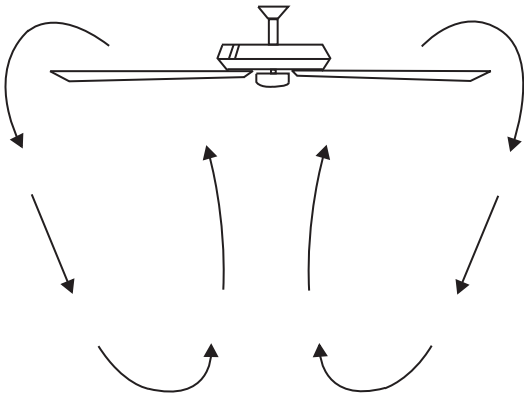

Fig. 19

NOTE: Please remember your control system is an RF (Radio Frequency) control system. You may occasionally experience control problems because of other radio frequency interference, i.e. fan turns off, light turns off or won't turn on, speed changes, etc. If this should happen, just change the "Control Frequency" by turning the power off and repeating steps 1 through 6 under System Programming.

Speed settings for warm or cool weather depend on factors such as the room size, Ceiling height, number of fans and so on.

Warm Weather Operation: Forward (counter clockwise) A downward airflow creates a cooling effect as shown in Fig. 18. This allows you to set your air conditioner on a warmer setting without affecting your general comfort.

Cool Weather Operation: Reverse (clockwise). An upward airflow moves warm air off the ceiling areas as shown in Fig. 19. This allows you to set your heating unit on a cooler setting without affecting your general comfort.

12. INSTALLING THE COOLTOUCH™ CONTROL SYSTEM WALL PLATE

Select a location to install your CoolTouch™ Control System Transmitter. You can replace an existing wall switch or, install the transmitter on ANY flat surface.

Option 1: Install the control system using an existing wall switch outlet box. Make sure the electrical power is **TURNED OFF** at the main panel before continuing.

Step 1. Remove the existing wall plate and the old switch from the wall outlet box. Wire nut the **BLACK** leads (hot) together and push back inside the outlet box. (Fig. 20)

Step 2. Install the metal plate and CoolTouch™ wall plate to the existing wall outlet box with 4 screws provided. Then place the two plastic plugs into the wall plate. (Fig. 21)

Option 2: Install the control system on ANY flat surface.

Select the desired location and use the CoolTouch™ wall plate to mark the location for the mounting holes. Use the dry wall anchors and/or screws provided and finish the installation.

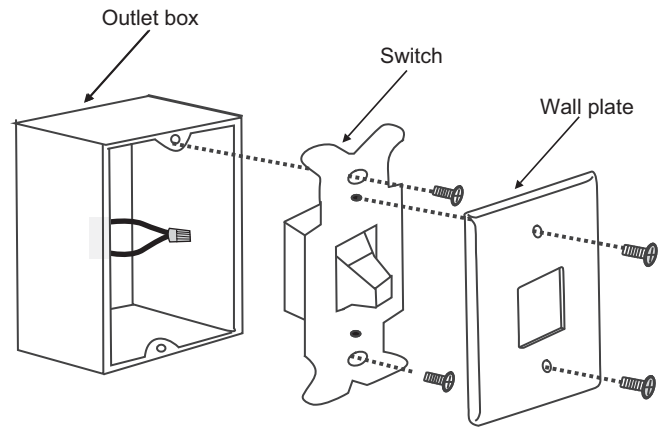

Fig. 20

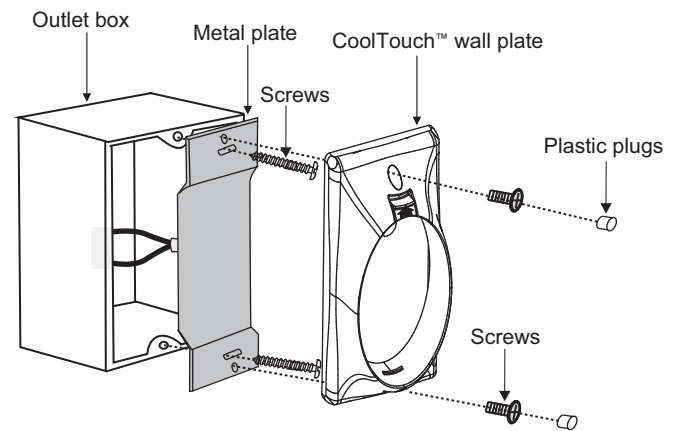

Fig. 21

13. INSTALLING THE TRANSMITTER

1. Insert the transmitter into the wall plate by inserting the bottom of the transmitter first and then press the top of the transmitter into the pocket. The transmitter will fully function from this location or you can remove the transmitter and use as a "Hand Held" device. (Fig. 22)

2. To remove the transmitter from the wall plate, push the release button and the transmitter will fall into your hand.

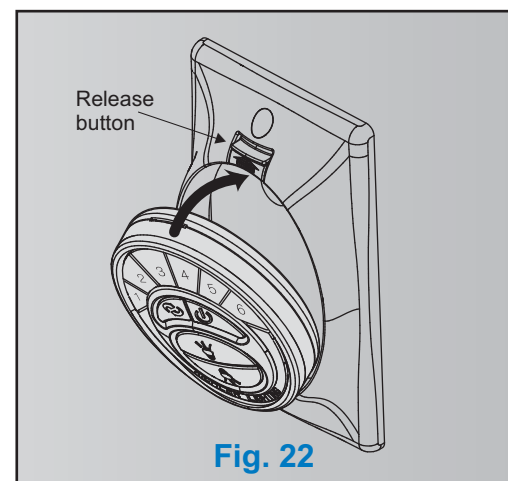

Fig. 22

14. TROUBLESHOOTING

Problem	Solution
Fan will not start.	<ol style="list-style-type: none"> 1. Check circuit fuses or breakers. 2. Check all electrical connections to insure proper contact. CAUTION: Make sure the main power is OFF when checking any electrical connection. 3. Make sure the transmitter batteries are installed properly. Positive (+) side facing out. 4. Insure the batteries have a good charge.
Fan sounds noisy.	<ol style="list-style-type: none"> 1. Make sure all motor housing screws are snug. 2. Make sure the screws that attach the fan blade brackets to the motor are tight. 3. Make sure wire nut connections are not rubbing against each other or the interior wall of the switch housing. CAUTION: Make sure main power is off. 4. Allow a 24-hour "breaking-in" period. Most noise associated with a new fan disappear during this time. 5. If using an optional light kit, make sure the screws securing the glassware are tight. Make sure the light bulbs are not touching any other component. 6. Do not connect this fan to wall mounted variable speed control(s). they are not compatible with ceiling fan motors or remote controls. 7. Make sure the upper canopy is a short distance from the ceiling. It should not touch the ceiling.
Fan wobble.	<ol style="list-style-type: none"> 1. Check that all blade and blade arm screws are secure. 2. Most fan wobbling problems are caused when blade levels are unequal. Check this level by selecting a point on the ceiling above the tip of one of the blades. Measure this distance. Rotate the fan until the next blade is positioned for measurement. Repeat for each blade. The distance deviation should be equal within 1/8". 3. Use the enclosed Blade Balancing Kit if the blade wobble is still noticeable. 4. If the blade wobble is still noticeable, interchanging two adjacent (side by side) blades can redistribute the weight and possibly result in smoother operation.
Remote control malfunction.	<ol style="list-style-type: none"> 1. Ceiling Fans with remote control systems CAN NOT be operated in conjunction with any other control system EXCEPT a basic On/Off wall switch, if desired.

15. SPECIFICATIONS

Fan Size	Speed	Volts	Amps	Watts	RPM	CFM	CFM/W	N.W.	G.W.	C.F.
54"	Extra-High	120	0.46	32.40	152	5126.23	158.22	26.40 kgs	30.80 kgs	1.94'
	High	120	0.30	20.40	131	4128.26	202.37			
	Medium High	120	0.20	13.20	111	3457.44	261.93			
	Medium	120	0.14	8.90	90	2988.25	335.76			
	Medium Low	120	0.09	5.60	71	2219.88	396.41			
	Low	120	0.06	3.40	51	1387.32	408.04			

These are approximate measurements. They do not include data for any lamps or fixtures attached to the ceiling fan.