

CRYSTORAMA

LIGHTING THE WAY FOR SIXTY YEARS



Crystorama.com

ASSEMBLY INSTRUCTION MODEL#XAN-8009-VG-BH

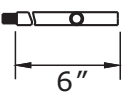
ROD 1 =  1Pc
6"

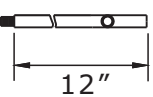
ROD 2 =  3Pcs
12"



All electrical components must be installed by a licensed electrician in accordance with the National Electric Code and the appropriate local electrical codes.



You will need 3 Candelabra Base
Bulb-5W LED Frosted bulb
60W Incandescent Equivalent
This fixture is Damp rated

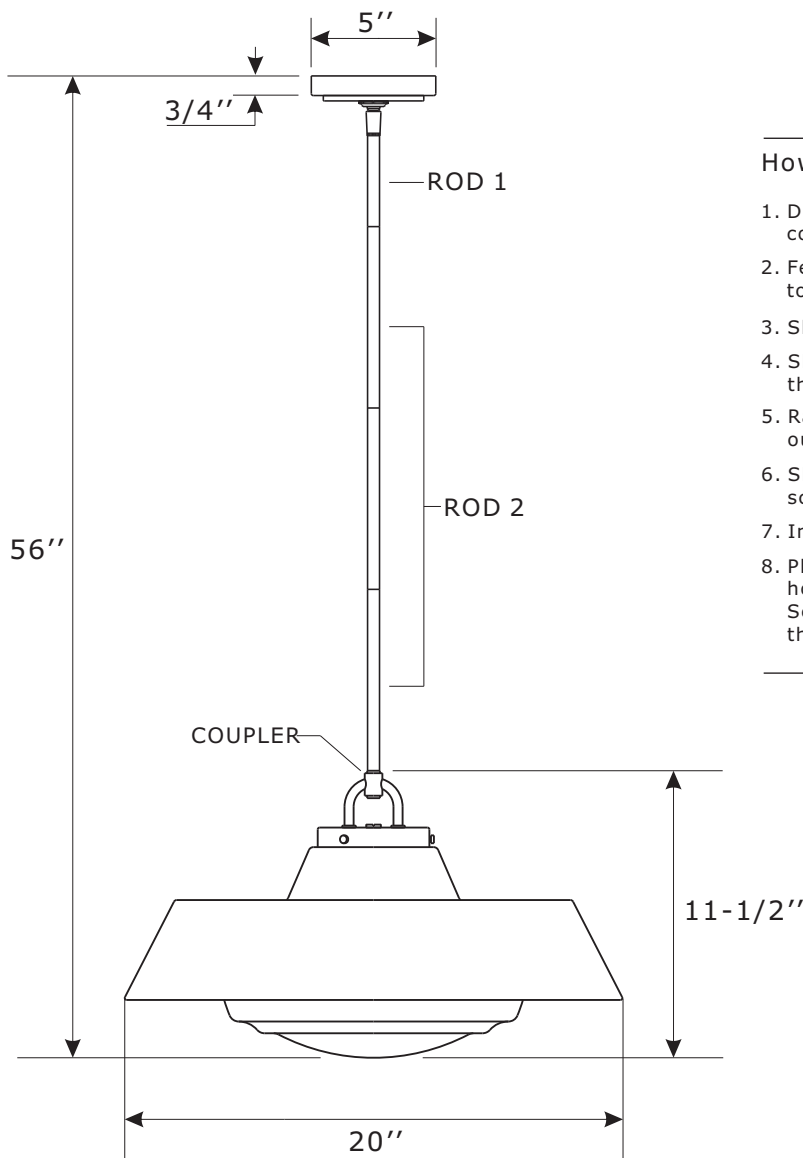

How to install

1. Determine the preferred hanging height and choose the correct length of rods needed.
2. Feed the wires through the rods and connect them together.
3. Slip collar ring and canopy over the rod assembly.
4. Slip mounting bar with swivel along wire and thread it into the top of the rod assembly.
5. Raise fixture up and attach mounting bar to the outlet box using two outlet box screws.
6. Slide collar ring up to canopy and thread it onto the screw collar, securing the canopy.
7. Install the bulb(not included) into the socket.
8. Place the metal shade gently over the glass shade and hold the glass shade up into the cap on the loop kit. Secure it with the cap nuts. Please do not overtighten the cap nuts to prevent the glass shade from breaking.

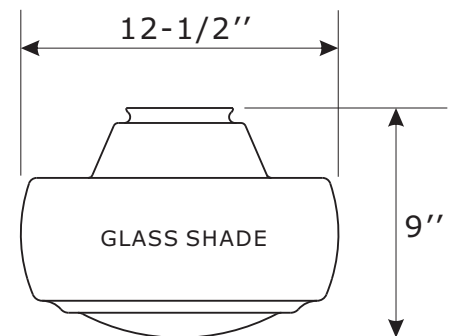

 **WARNING:** This product can expose you to Lead which is known to the state of California to cause cancer and/or birth defects or reproductive harm. For more information go to www.P65Warnings.ca.gov



Part Number

Part Numbers

- A. (1)-Mounting hardware
- B. (1)-Canopy D5''xH3/4'' #XRF8006VGCAN5IN
- C. (1)-Short rod D1/2''xL6'' #XRF8006VGRD6IN
- D. (3)-Long rod D1/2''xL12'' #XRF8006VGRD12IN
- E. (1)-Loop kit
- F. (3)-Cap nut
- G. (1)-Metal shade #XRF8009BHSHA20IN
- H. (1)-Glass shade D12-1/2''xH9'' #XRF8009GLA12.5IN

