

ASSEMBLY INSTRUCTION

ITEM: N715P227667

BAR TABLE

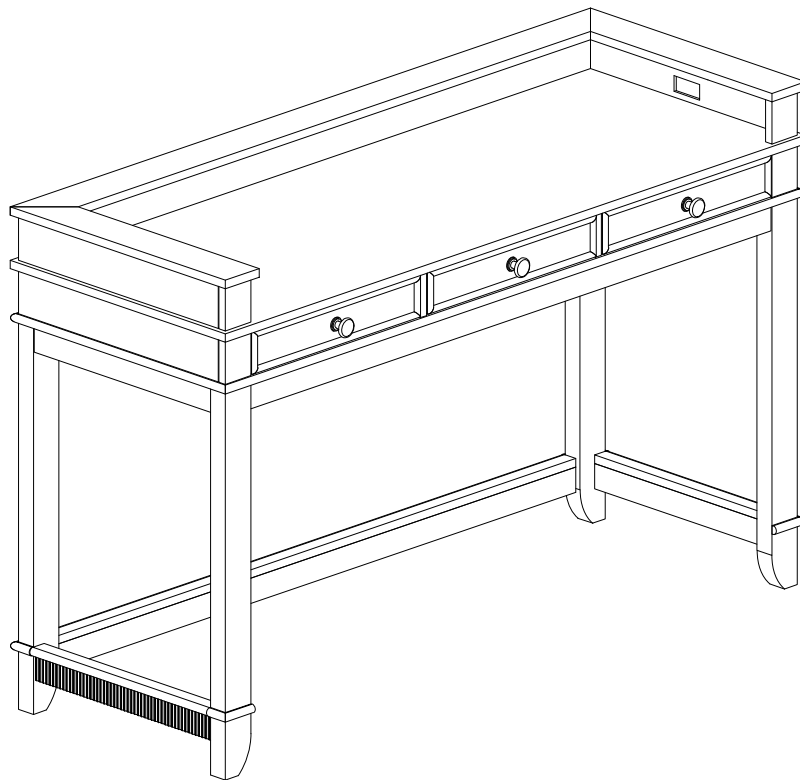

IMPORTANT NOTE :

Please read these INSTRUCTION fully before starting assembly:

1. Place all wooden parts on a clean and smooth surface such as a rug or carpet to avoid scratching the parts.
2. Kindly follow the assembly INSTRUCTION step by step.
3. Do not tighten all screws and bolts until the table is fully assembled.
4. Unscrew the protective plastique supports from the metal insert of the table legs before assembly.
5. Parts of the assembly will be easier with 2 people.

Care and maintenance:

Only clean using a damp cloth and mild detergent, do no use bleach or abrasive cleaners.

A

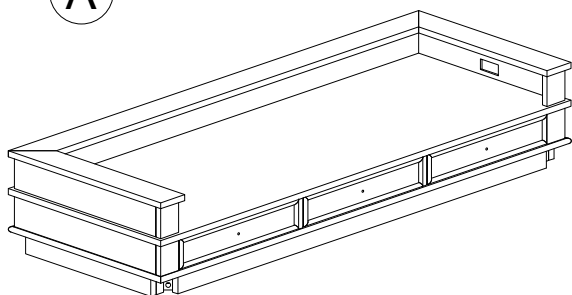

B

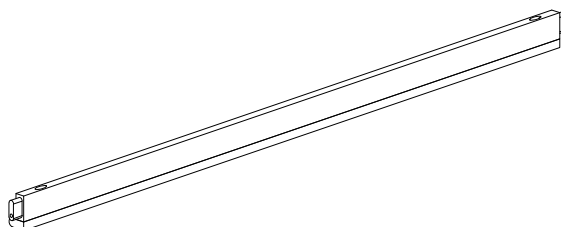

C

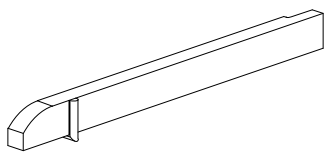



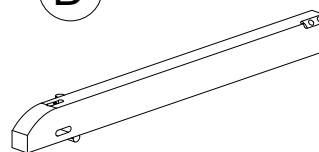

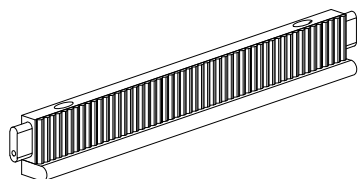

D

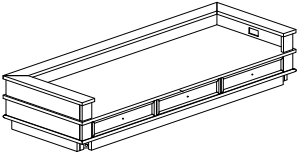
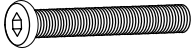
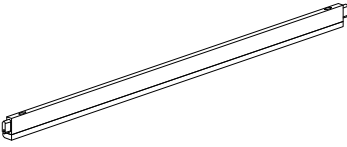
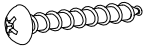
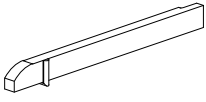

E

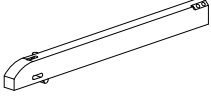

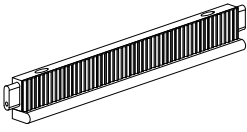
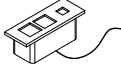
PART AND HARDWARE LIST

Part List For One	Hardware List For One
<p>(A)</p>  <p>TABLE TOP (1 pc)</p>	<p>(1)</p>  <p>Ø5/16" x 60mm</p> <p>BOLT (8 pcs)</p>
<p>(B)</p>  <p>STRECHER (1 pc)</p>	<p>(2)</p>  <p>M4 x 45mm</p> <p>ROUND HEAD SCREW (6 pcs)</p>
<p>(C)</p>  <p>FRONT LEG (2 pcs)</p>	<p>(3)</p>  <p>Ø5/16" x 19mm</p> <p>FLAT WASHER (8 pcs)</p>
<p>(D)</p>  <p>BACK LEG (2 pcs)</p>	<p>(4)</p>  <p>Ø5/16" x 13mm</p> <p>LOCK WASHER (8 pcs)</p>
<p>(E)</p>  <p>STRECHER (2 pcs)</p>	<p>(5)</p>  <p>DESK OUTLET WITH USB (1 pc)</p>
	<p>(6)</p>  <p>M3 x 15mm</p> <p>C-SCREW (2 pcs)</p>
	<p>(7)</p>  <p>M4 x 60mm</p> <p>ALLEN KEY (1 pc)</p>

ASSEMBLY INSTRUCTION



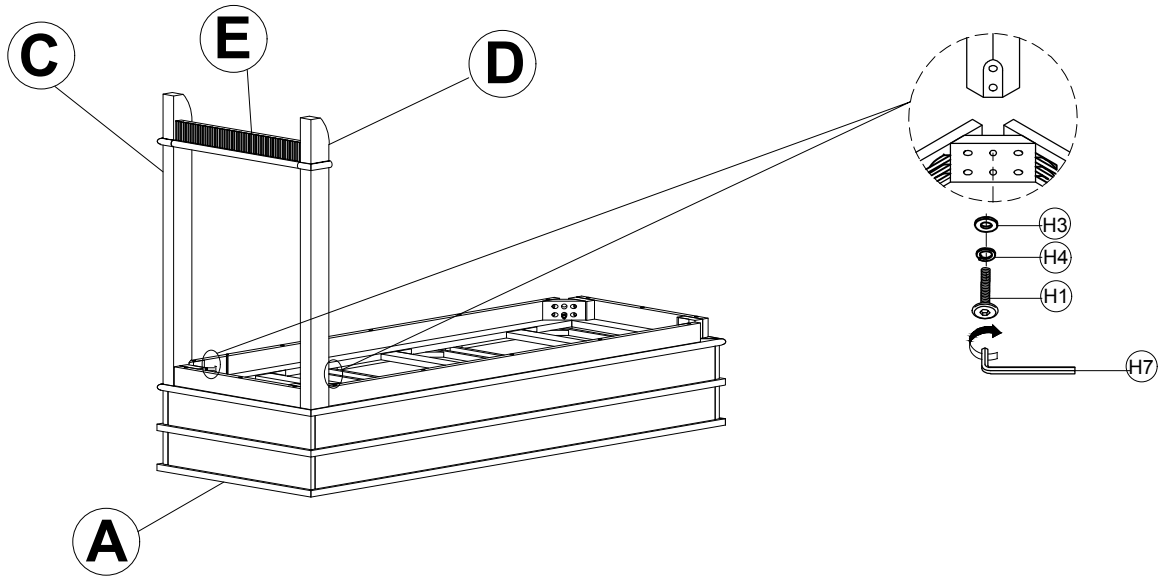

ITEM: N715P227667

STEP 1:

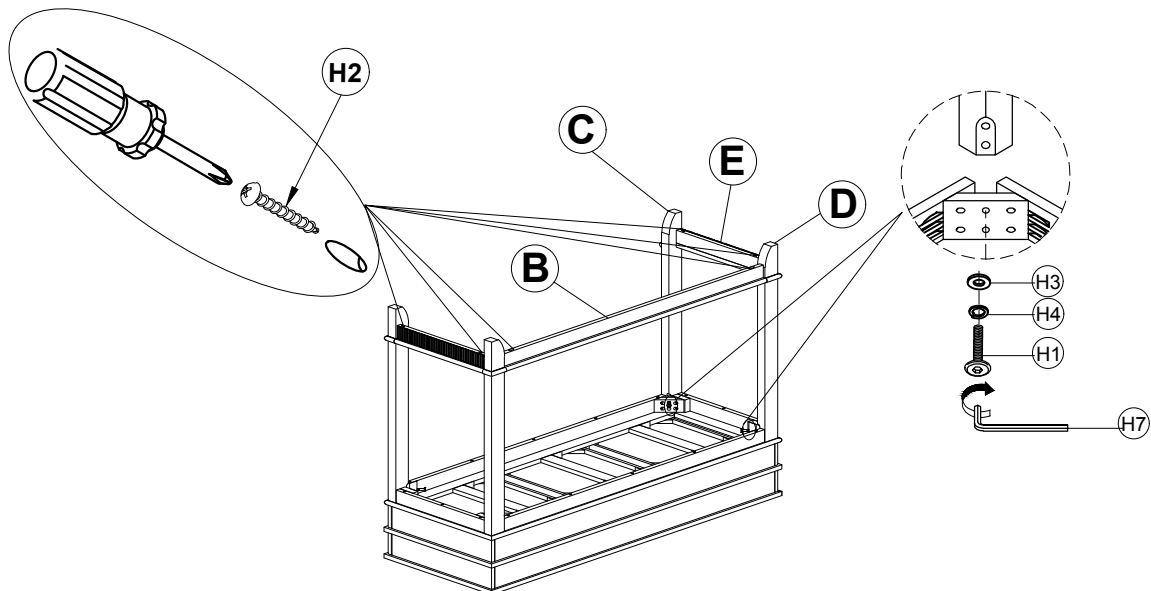

STEP 2:



Bolts 5/16" x 60mm	Round head screw M4 x 45mm	Flat Washer 5/16" x 19mm	Lock Washer 5/16" x 13mm	Allen Key M4 x 60mm
				
(H1) x 8	(H2) x 6	(H3) x 8	(H4) x 8	(H7) x 1

MADE IN VIETNAM



PAGE 4 OF 5

ASSEMBLY INSTRUCTION

ITEM: N715P227667

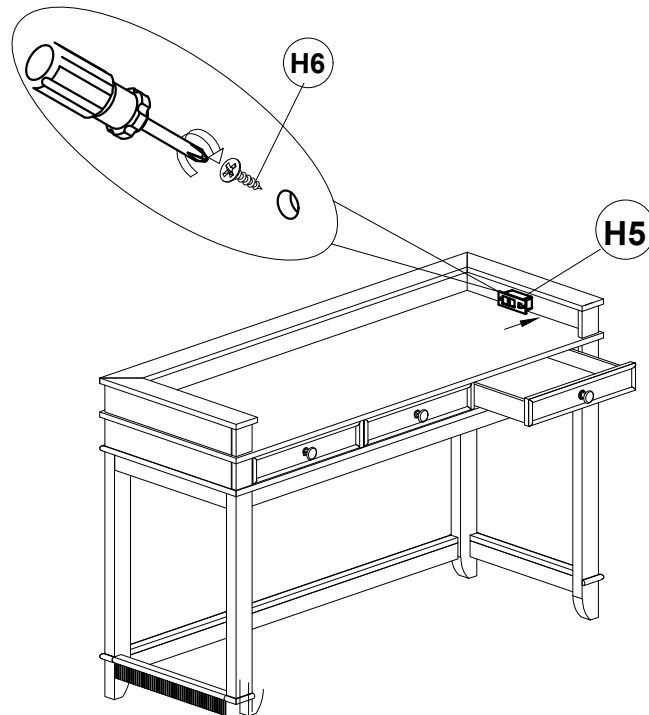
STEP 3:

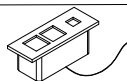

Desk Outlet with USB	C- screw M3 x 15mm
 (H5) x 1	 (H6) x 2

Be sure the legs are level
then fully tighten the leg bolts!

COMPLETE

