

# Fireplace / Le Foyer

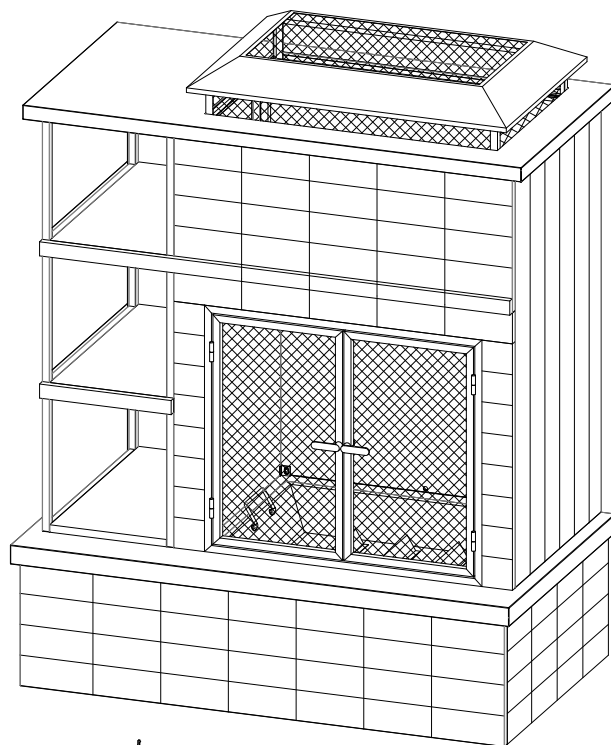

## Warnings:

**This Fireplace is intended for outdoor use only. NEVER LEAVE A FIRE UNATTENDED.**

- DO NOT use the fireplace to cook food. The fireplace is not designed for grilling food.
- DO NOT allow children or pets near the fireplace without supervision.
- DO NOT touch the surface of the fireplace while in use as it may cause burns.
- NEVER burn in vehicles, tents or indoors. CARBON MONOXIDE HAZARD.
- Use a poker and / or heat-resistant gloves to open / close the mesh cover while in use.
- DO NOT use water to extinguish as this is dangerous and can cause damage to the fireplace.
- Burn only untreated wood or fire logs in this fireplace.
- DO NOT use gasoline or kerosene to start the fire in this fireplace.
- Only place/use this fire place on stable and non-combustible surfaces.
- DO NOT attempt to move the fireplace while it is hot or in use.
- Place the fire place no closer than 8' (2.4 m) from walls or combustibles during use.
- Adequate fire extinguishing material should be readily available.
- Always ensure that the mesh cover is secured over the fireplace while in use.
- NEVER leave a burning fire unattended when in use. Always extinguish fire completely before leaving it.
- DO NOT COVER THE UNIT UNTIL FIRE HAS BEEN EXTINGUISHED FOR 24 HOURS.
- The poker handle may become hot during and after use.
- Check local fire regulations and municipal by-laws for information regarding the safe use of this fireplace.
- The maximum amount of firewood should be stacked no higher than 1/3 of the fireplace height.
- Body always use caution while using your fire place.

## Avertissement:





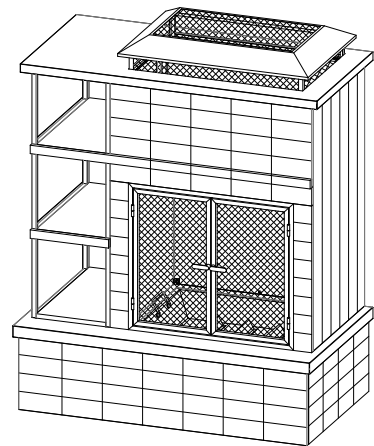
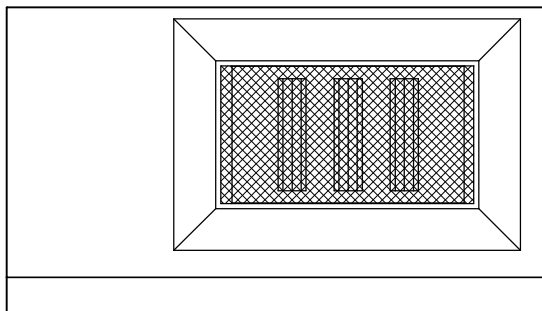
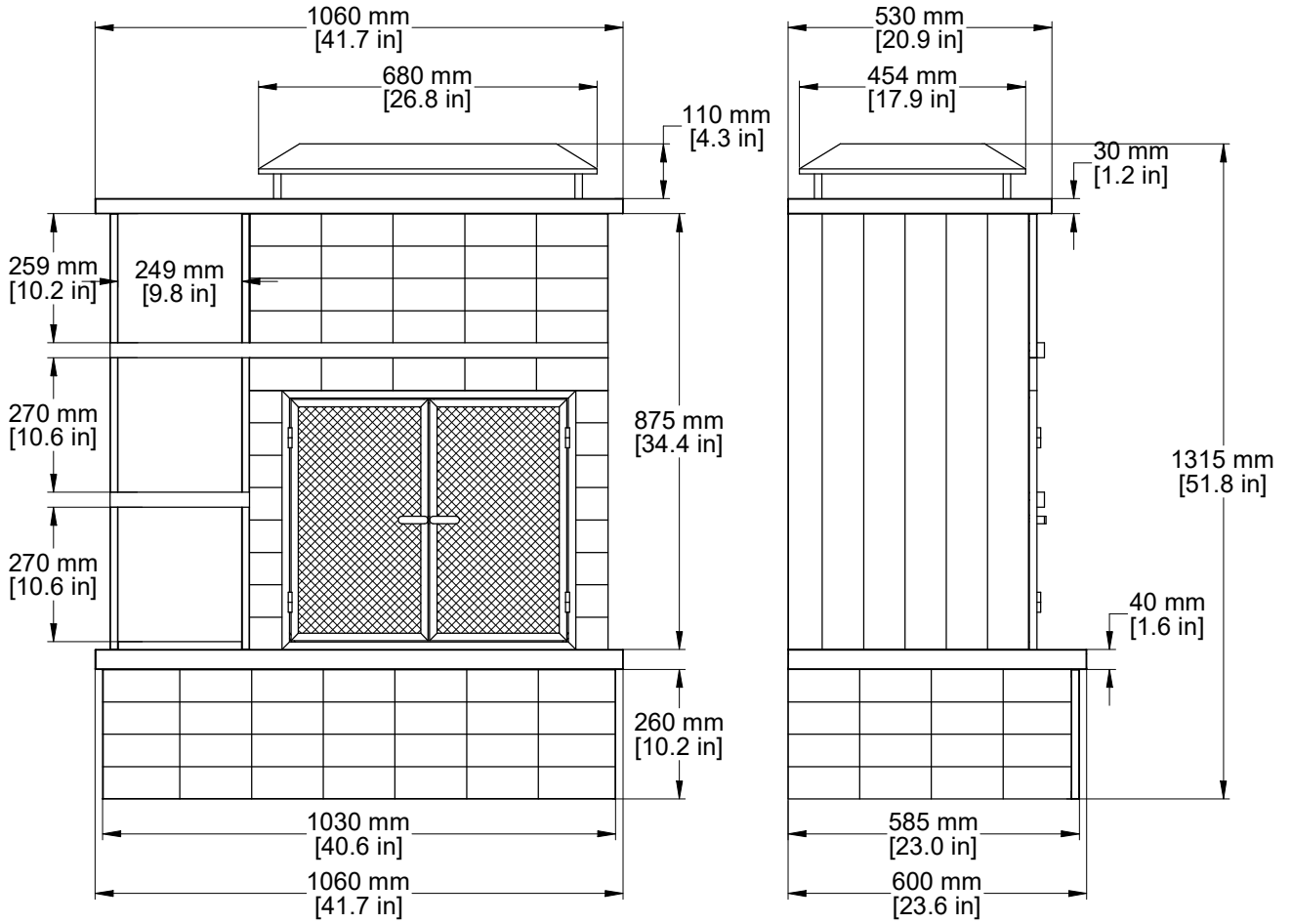

### **Ce foyer est conçu pour un usage extérieur seulement. NE LAISSEZ JAMAIS UN FEU SANS SURVEILLANCE**

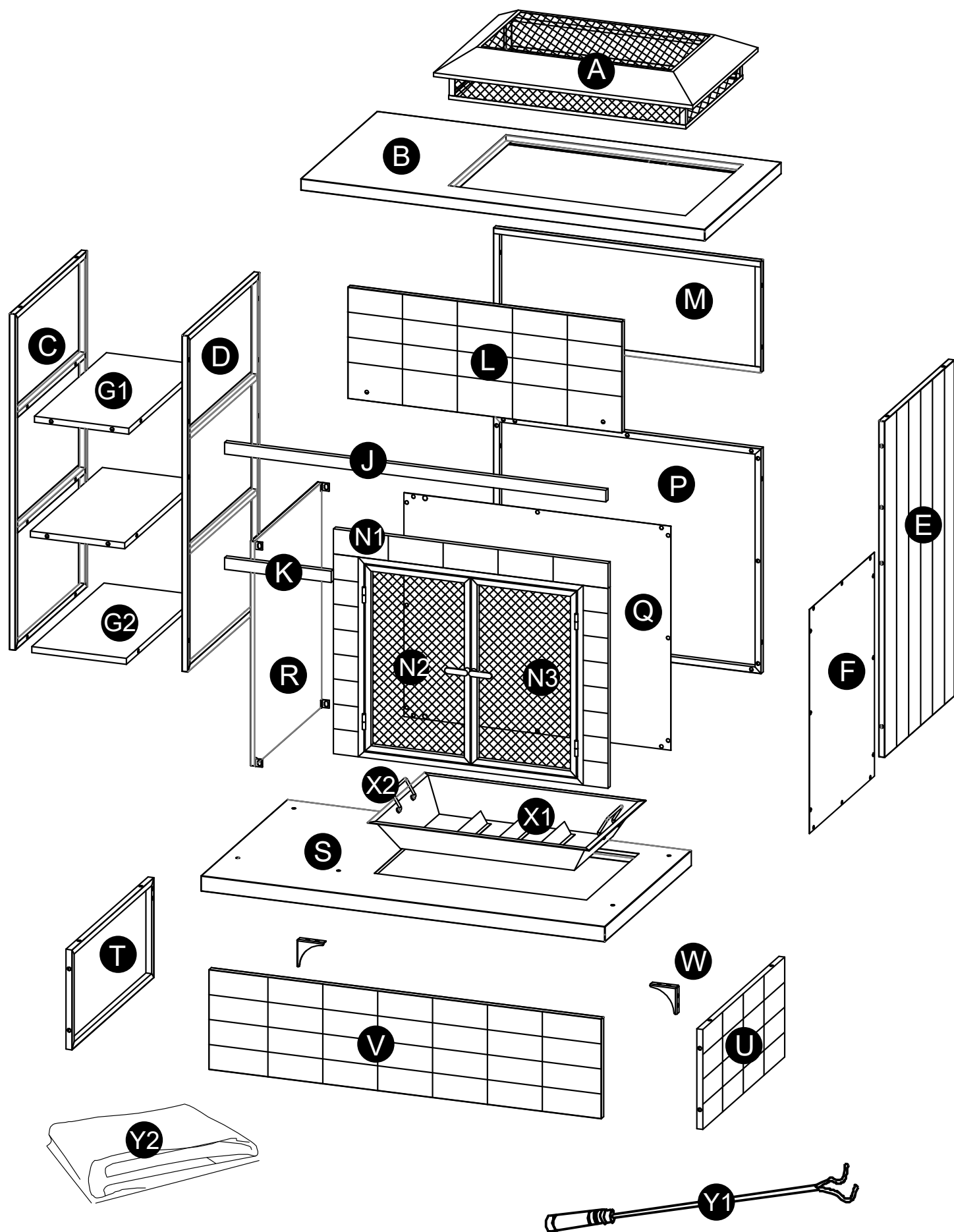

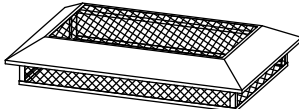
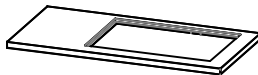
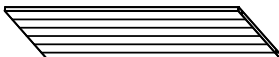



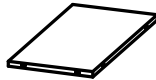
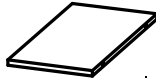

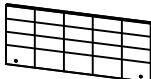

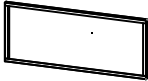
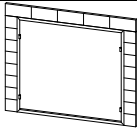
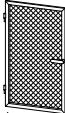
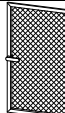
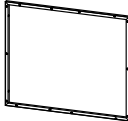
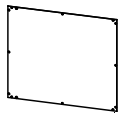
- N'utilisez PAS ce foyer pour faire cuire de la nourriture. Il n'est pas conçu pour un tel usage.
- NE laissez PAS les enfants et les animaux s'approcher du foyer sans surveillance.
- NE touchez PAS à la surface du foyer lorsque vous l'utilisez, car vous pourriez vous brûler.
- NE l'utilisez JAMAIS dans un véhicule, dans une tente ou à l'intérieur. RISQUE D'INTOXICATION PAR LE MONOXYDE DE CARBONE.
- Lorsque vous utilisez le foyer, servez-vous d'un tisonnier ou de gants résistants à la chaleur pour ouvrir ou fermer le couvercle grillagé.
- N'utilisez PAS d'eau pour éteindre le feu. Cette pratique est dangereuse et pourrait endommager le foyer.
- Ne brûlez que des bûches ou du bois non traité.
- N'utilisez PAS d'essence ni de kérosène pour allumer le foyer.
- Placez et utilisez ce foyer uniquement sur des surfaces stables et incombustibles.
- N'essayez PAS de déplacer le foyer lorsqu'il est allumé ou encore chaud.
- Placez le foyer à au moins 8 pi (2,4 m) des murs ou de toute matière combustible lorsqu'il est en cours d'utilisation.
- Un matériel d'extinction d'incendie convenable doit être facilement disponible.
- Assurez-vous toujours que le couvercle en maille soit placé sur la cheminée pendant l'emploi.
- NE laissez JAMAIS un feu allumé sans surveillance lorsque vous l'utilisez. Éteignez toujours complètement le feu avant de vous éloigner.
- ATTENDEZ AU MOINS 24 HEURES APRÈS QUE LE FEU SOIT ÉTEINT AVANT DE COUVRIR L'APPAREIL.
- La poignée du tisonnier peut être très chaude pendant et après l'emploi.
- Vérifiez les règlements de votre localité et les règlements municipaux en matière d'incendie pour obtenir de l'information à propos de l'emploi sain et sauf de cette cheminée
- La quantité maximale de bûches à brûler ne doit pas être à plus de 1/3 de la hauteur du récipient du foyer.
- Soyez toujours prudent pendant que vous utilisez le foyer.

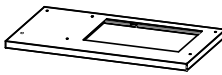

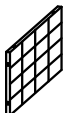
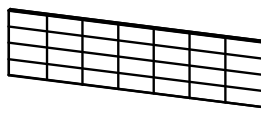

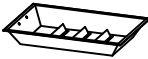

## EXPLODED DRAWING/DESSIN ÉCLATÉ

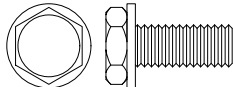
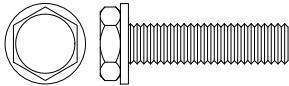

Parts List/Liste de Pièces				
Label Étiquette	Part Number/ Numéro de la Pièce	Description	Qty Quantité	Part Image/Numéro de la Pièce Diagramme
A	P00090023701	Top Cover/ Toiture	1	
B	P00030012001	Upper Base/ Base Supérieure	1	
C	P00380076501	Left Side Panel / Panneau latéral gauche	1	
D	P00380076601	Middle Panel/ Panneau Central	1	
E	P00380076701	Right Side Panel /Panneau du Côté Droit	1	
F	P00380076801	Inner Side Panel 1 / Panneau latéral intérieur 1	1	
G1	P00420006901	Shelf 1/Étagère 1	2	
G2	P00420007001	Shelf 2 / Étagère 2	1	
J	P00560064801	Decoration 1/ Ornement 1	1	
K	P00560064901	Decoration 2/ Ornement 2	1	
L	P00390019101	Front Panel/ Face avant	1	

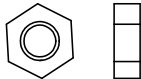
M	P00400044401	Back Panel 1/ Panneau arrière 1	1	
N1	P00410024601	Door/Porte	1	
N2	P00410028001	Left Door (Preloaded on N1)/ Porte gauche (préchargée sur N1)	1	
N3	P00410028101	Right Door(Preloaded on N1)/Porte droite (préchargée sur N1)	1	
P	P00400044501	Back Panel 2/ Panneau arrière 2	1	
Q	P00400044601	Back Panel 3/ Panneau arrière 3	1	
R	P00380076901	Inner Side Panel 2 /Panneau latéral intérieur 2	1	
S	P00370004801	Base Top Panel/ Base Panneau supérieur	1	
T	P00400044701	Base Left Side Panel /Base Panneau latéral gauche	1	
U	P00400044801	Base Right Side Panel / Base Panneau latéral droit	1	
V	P00390019201	Base Front Panel/ Panneau avant de la base	1	
W	P00500098301	Triangle Support/ Soutien au triangle	2	
X1	P00250017101	Fire Bowl/Foyer	1	
X2	P00510042601	Handle/Poignée	2	
Y1	P002700014	Poker/ Tisonnier	1	
Y2	P00690006501	PVC Cover/ Couverture en PVC	1	

<b>Hardware Pack/ Liste de Pièces</b>				
<b>Label/ Étiquette</b>	<b>Part Number/ Numéro de la Pièces</b>	<b>Description</b>	<b>Qty/ Quantité</b>	<b>Part Image/Numéro de la Pièces Diagramme</b>
H1	H100010068	Bolt M6*15/ Boulon M6*15	56	
H2	H100010086	Bolt M6*25/ Boulon M6*25	28	
H3	H050010025	Plain Washers- Product Grade C 6x12/Rondelles plates - Grade C 6x12	8	
H4	H040010004	Hexagon Nuts, M6/ Écrous hexagonaux, M6	8	
HW	H090010017	Wrench M6/ Clé M6	2	

**1**

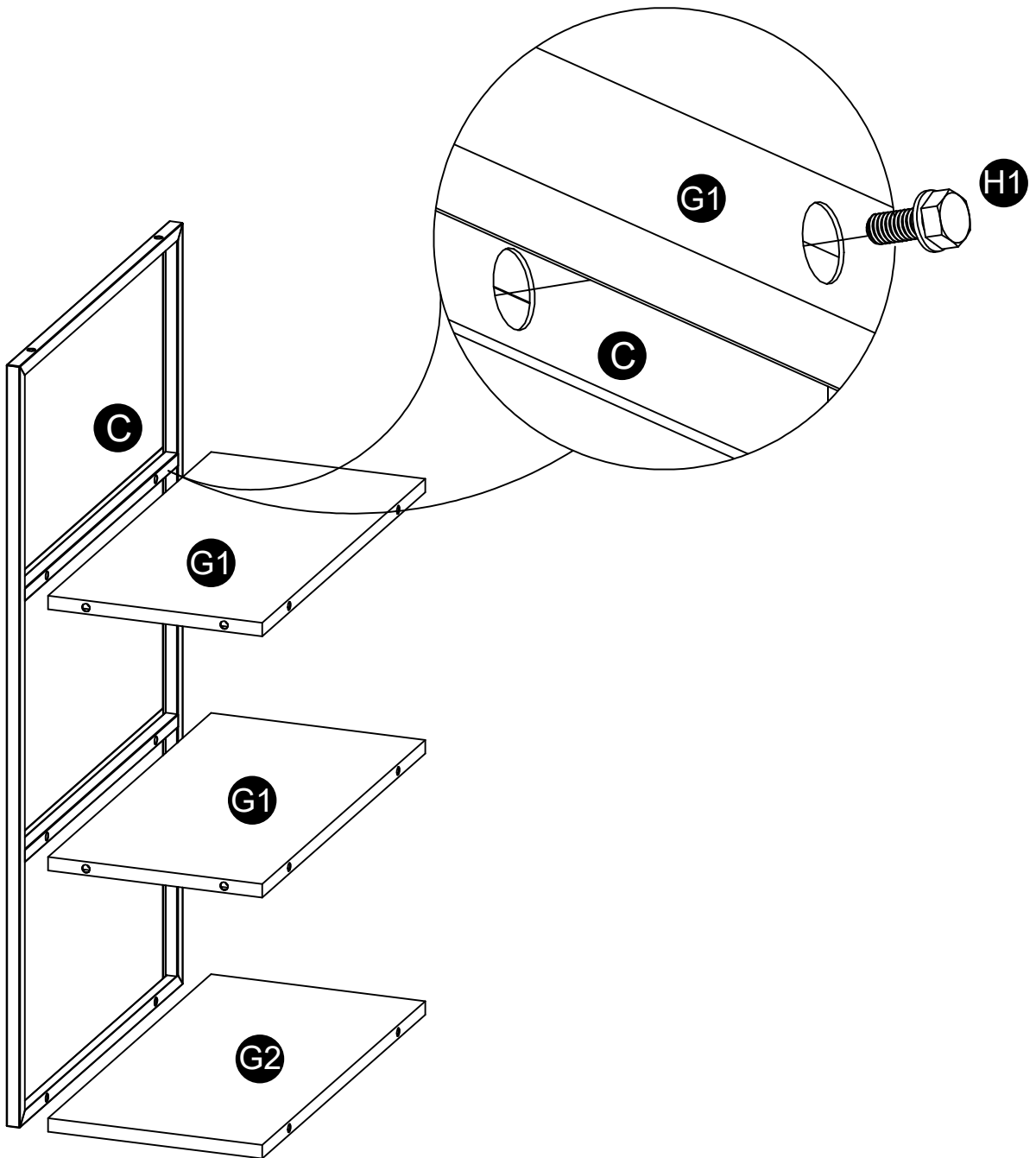
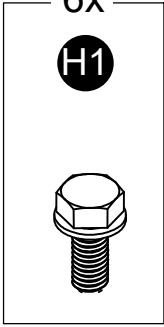
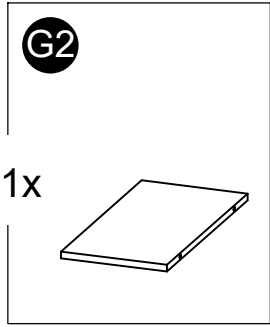
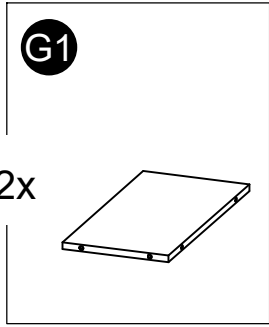
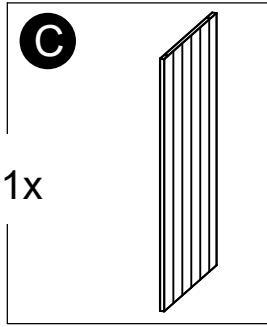

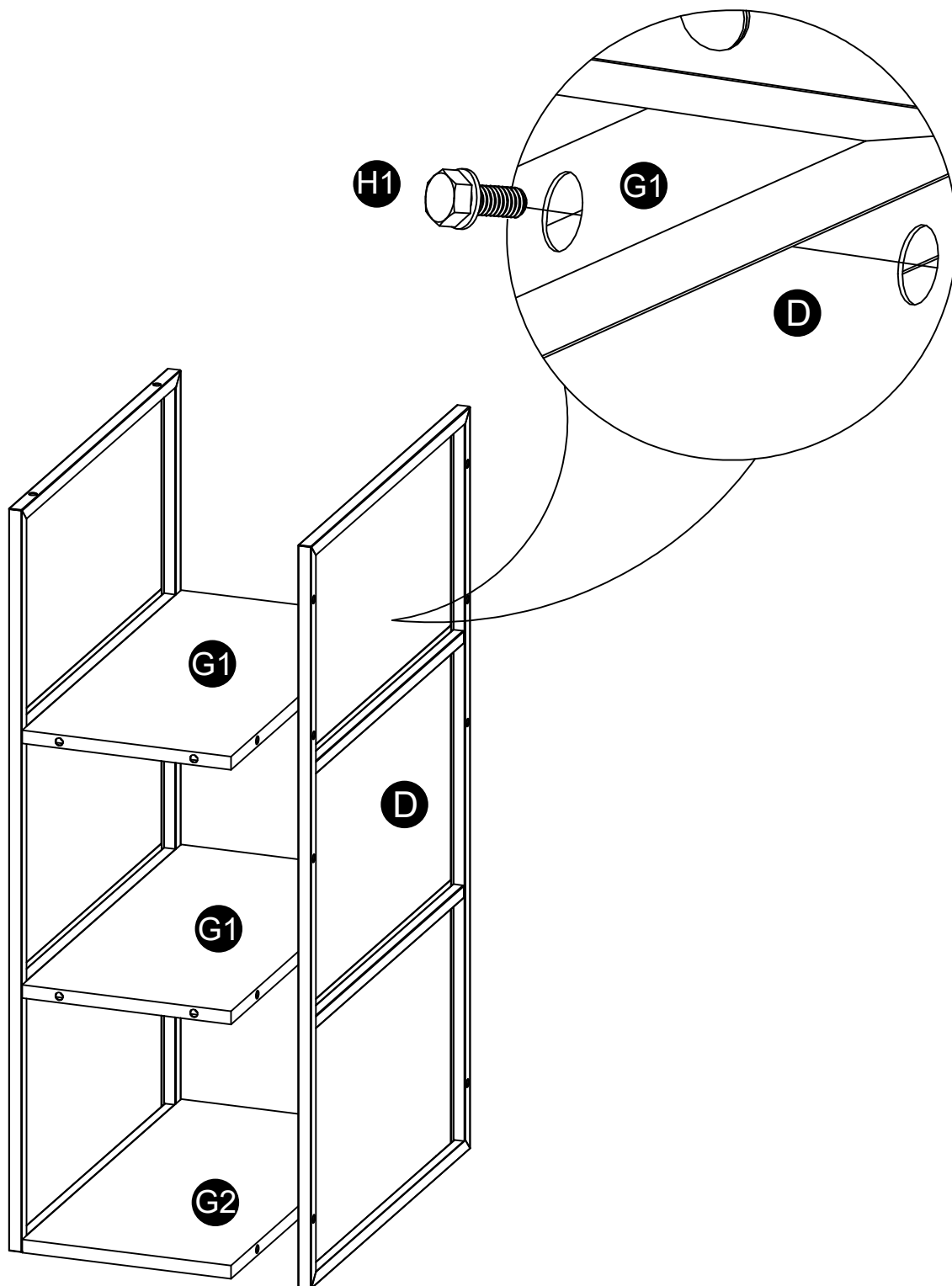
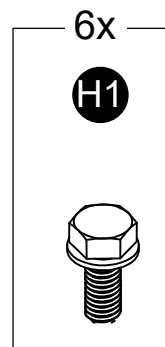
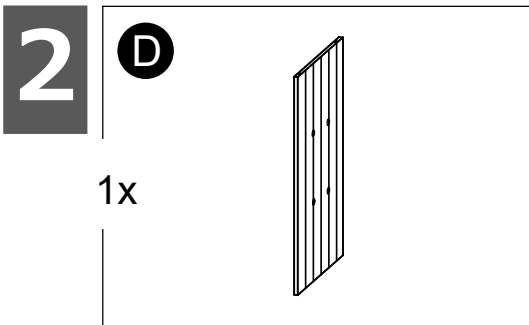

**3**

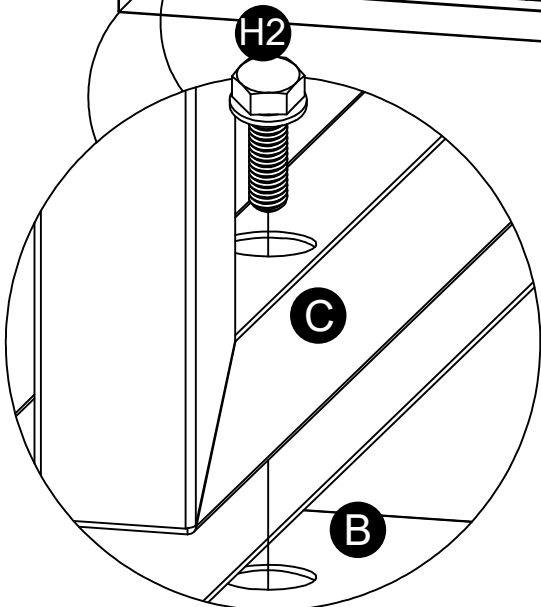
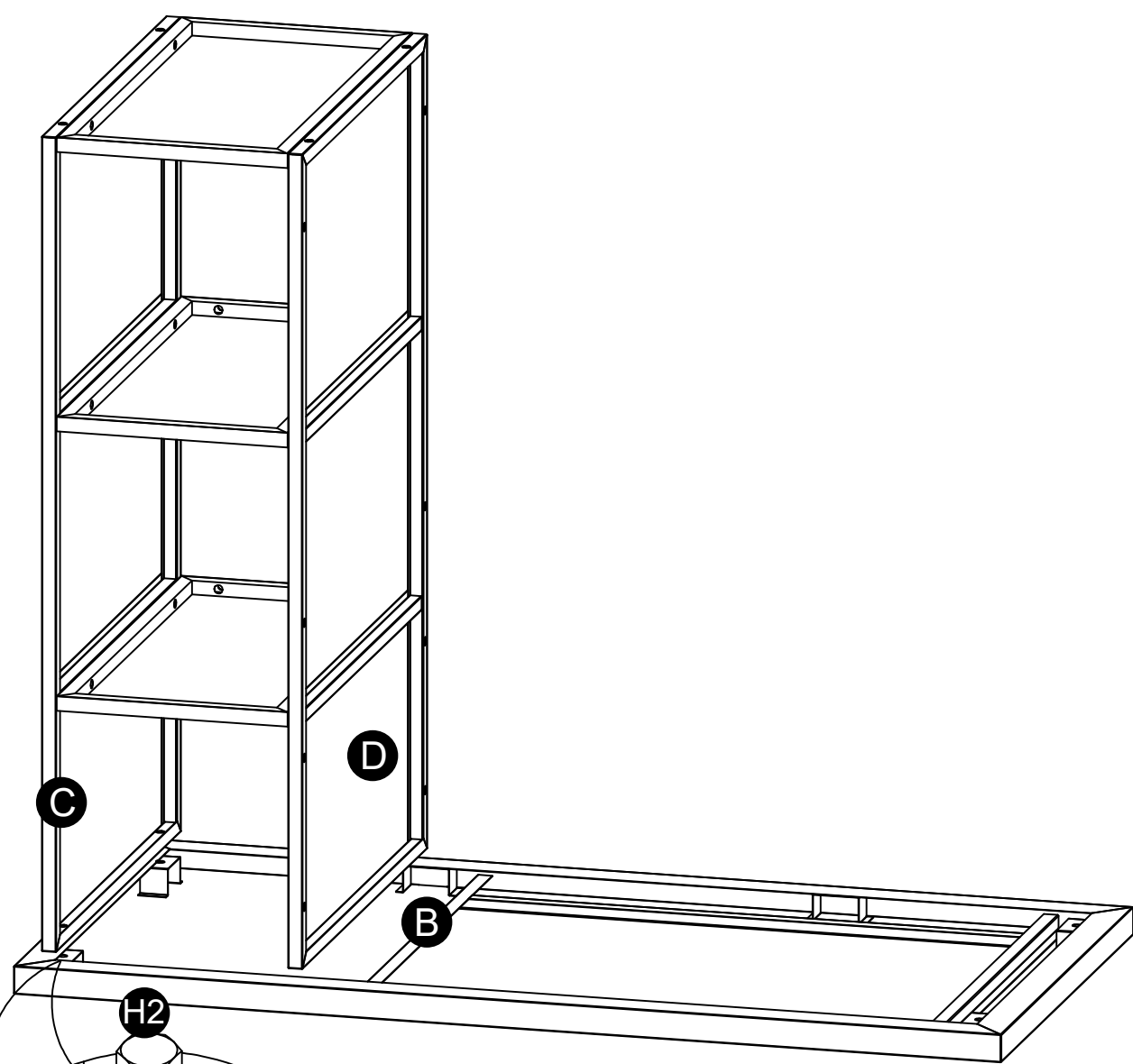
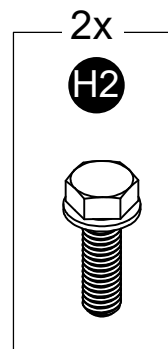
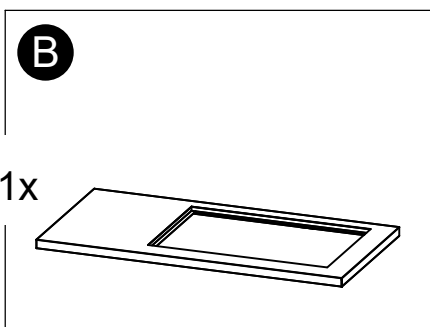

4

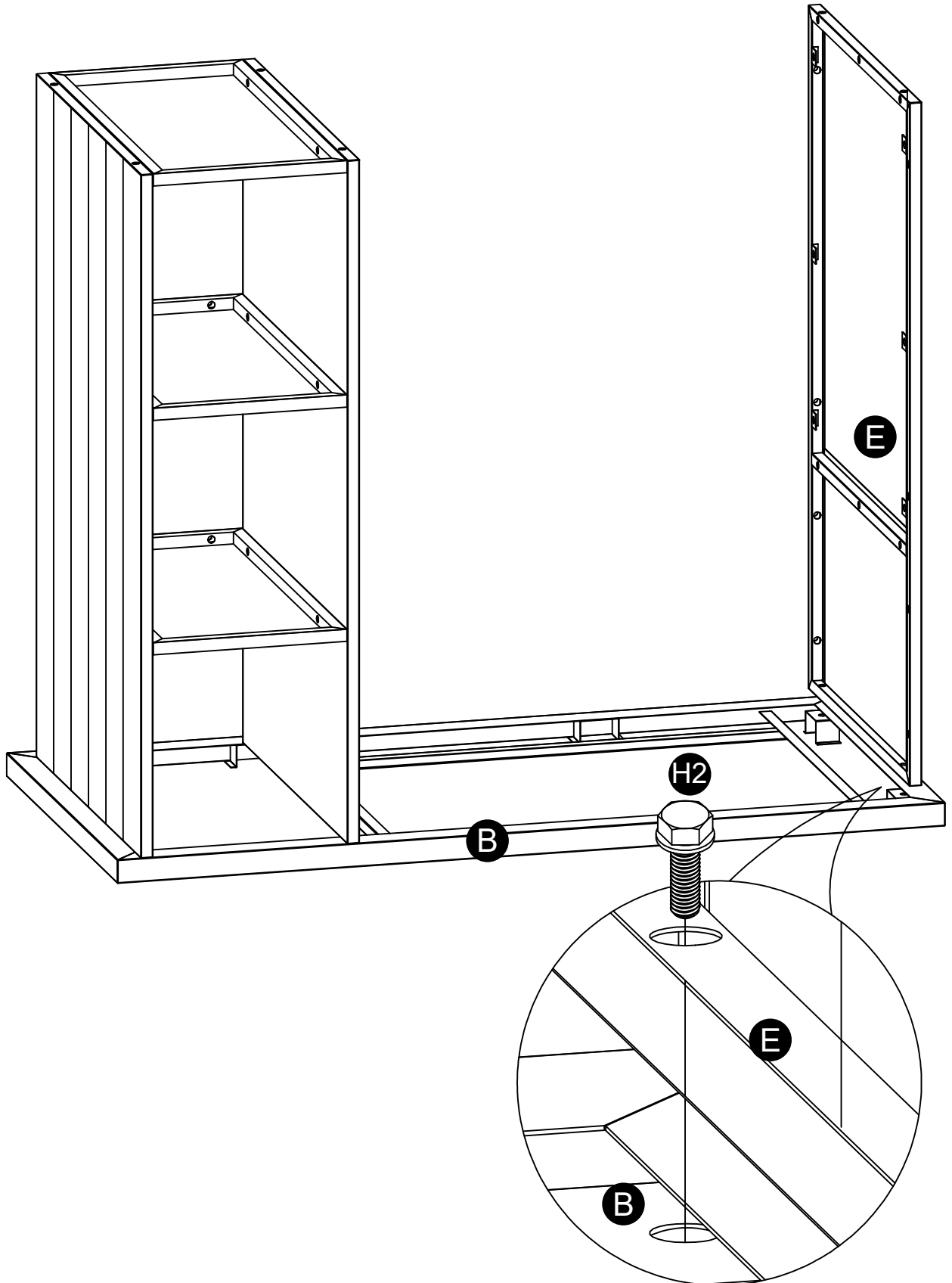
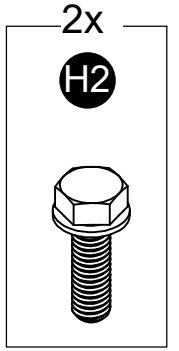
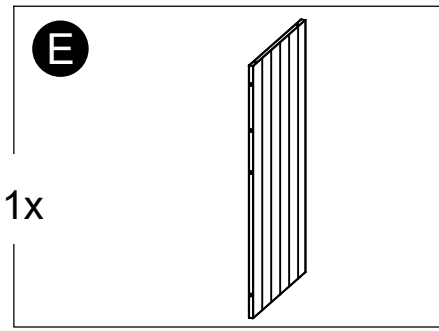

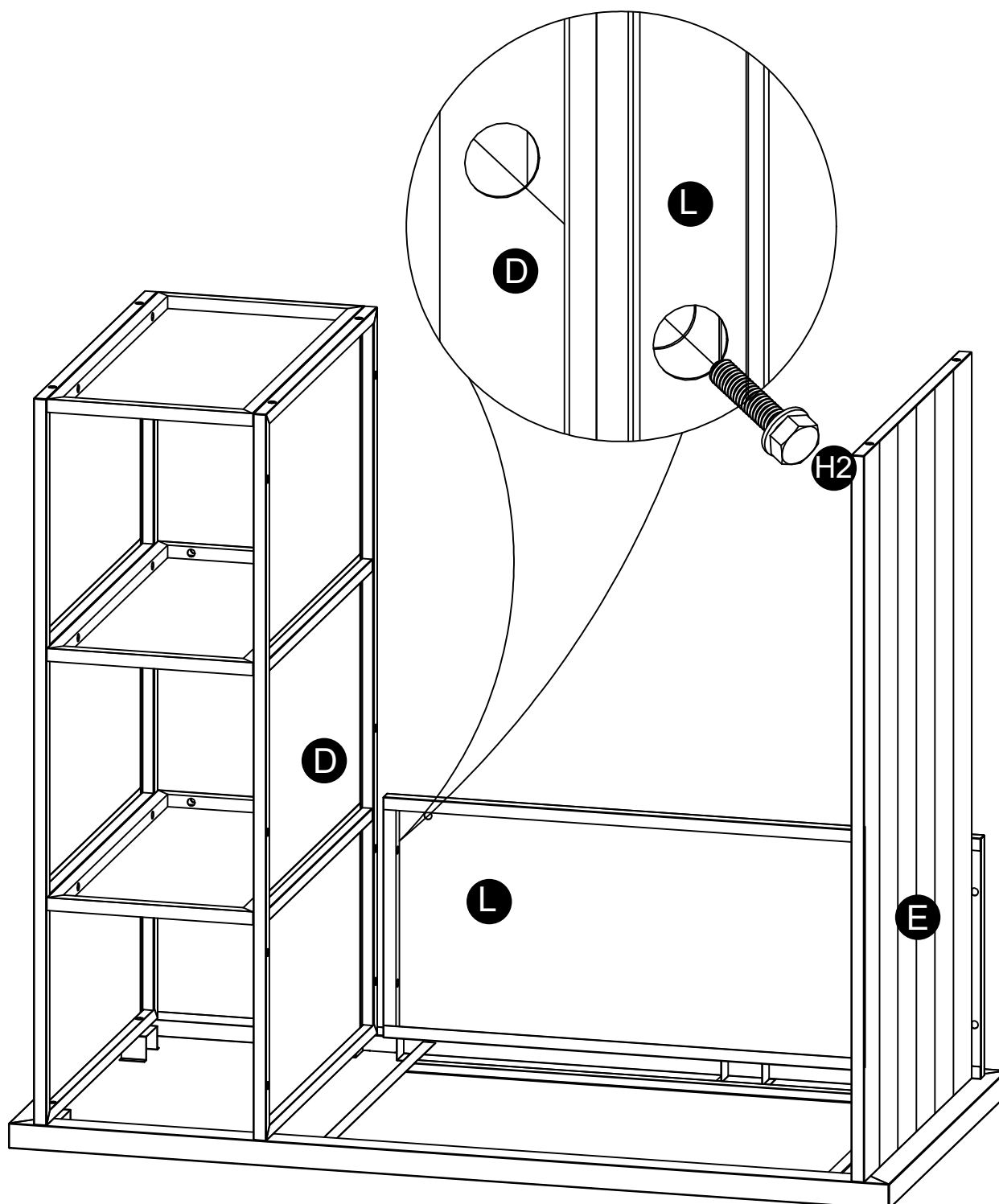
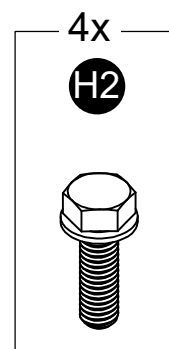
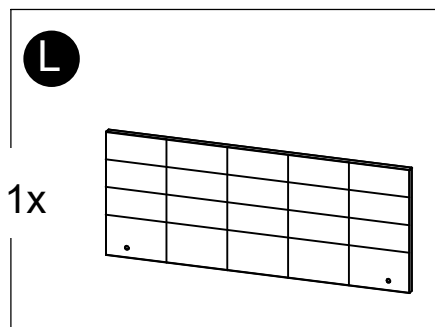
**5**

6

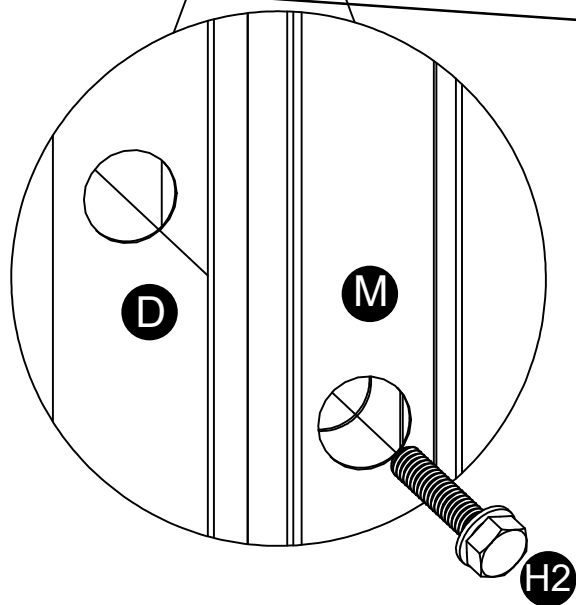
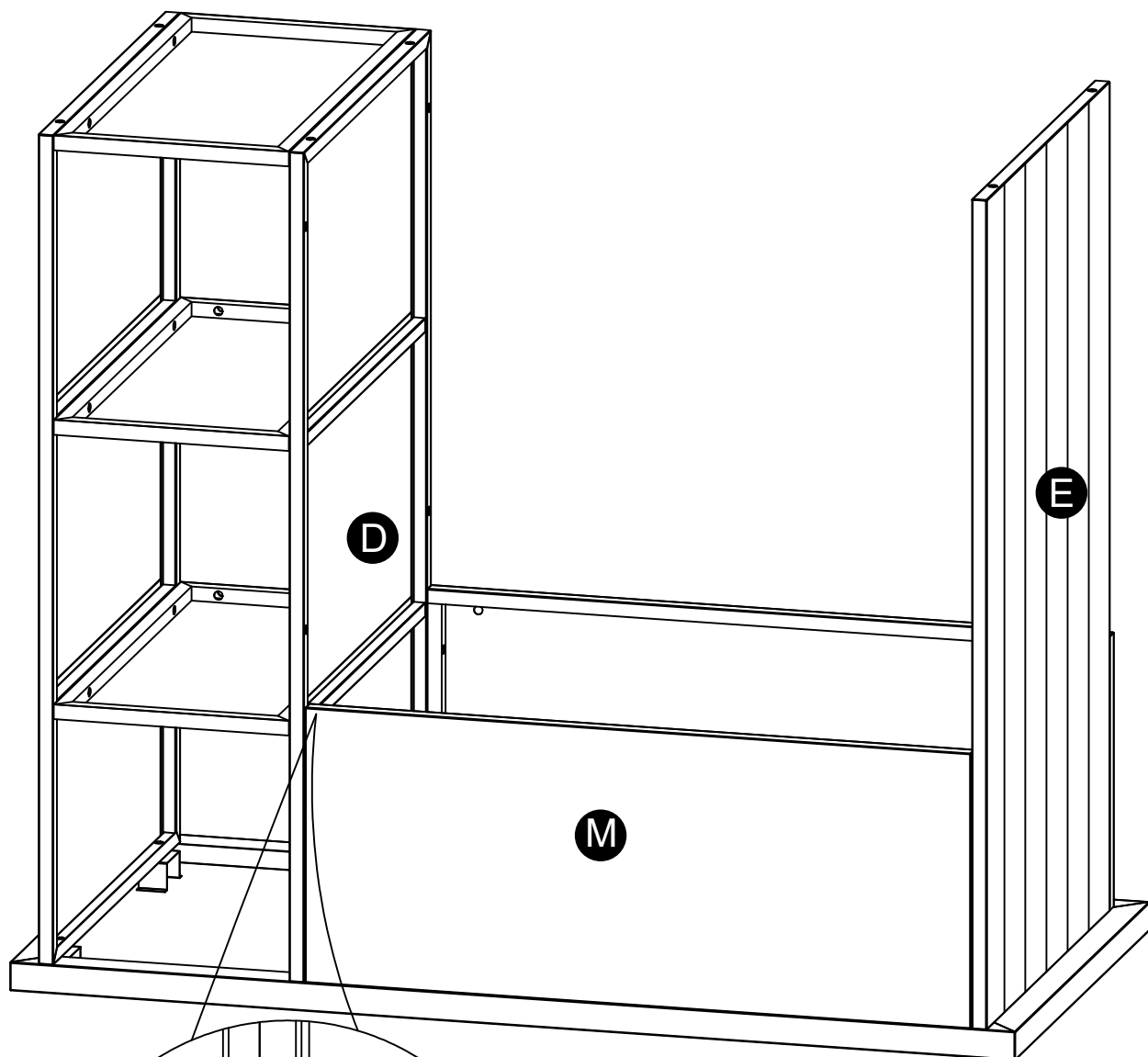
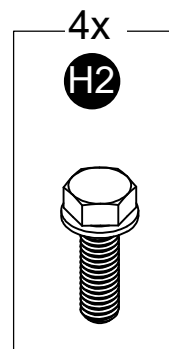
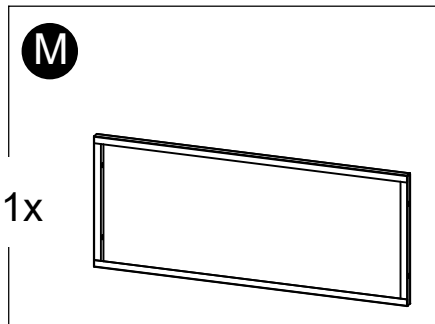

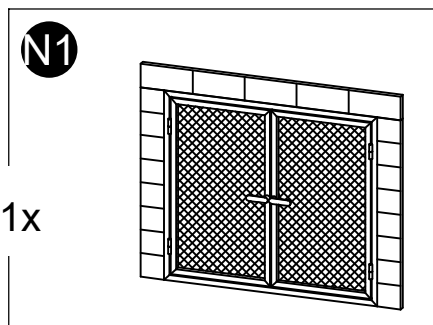
**7**

4x

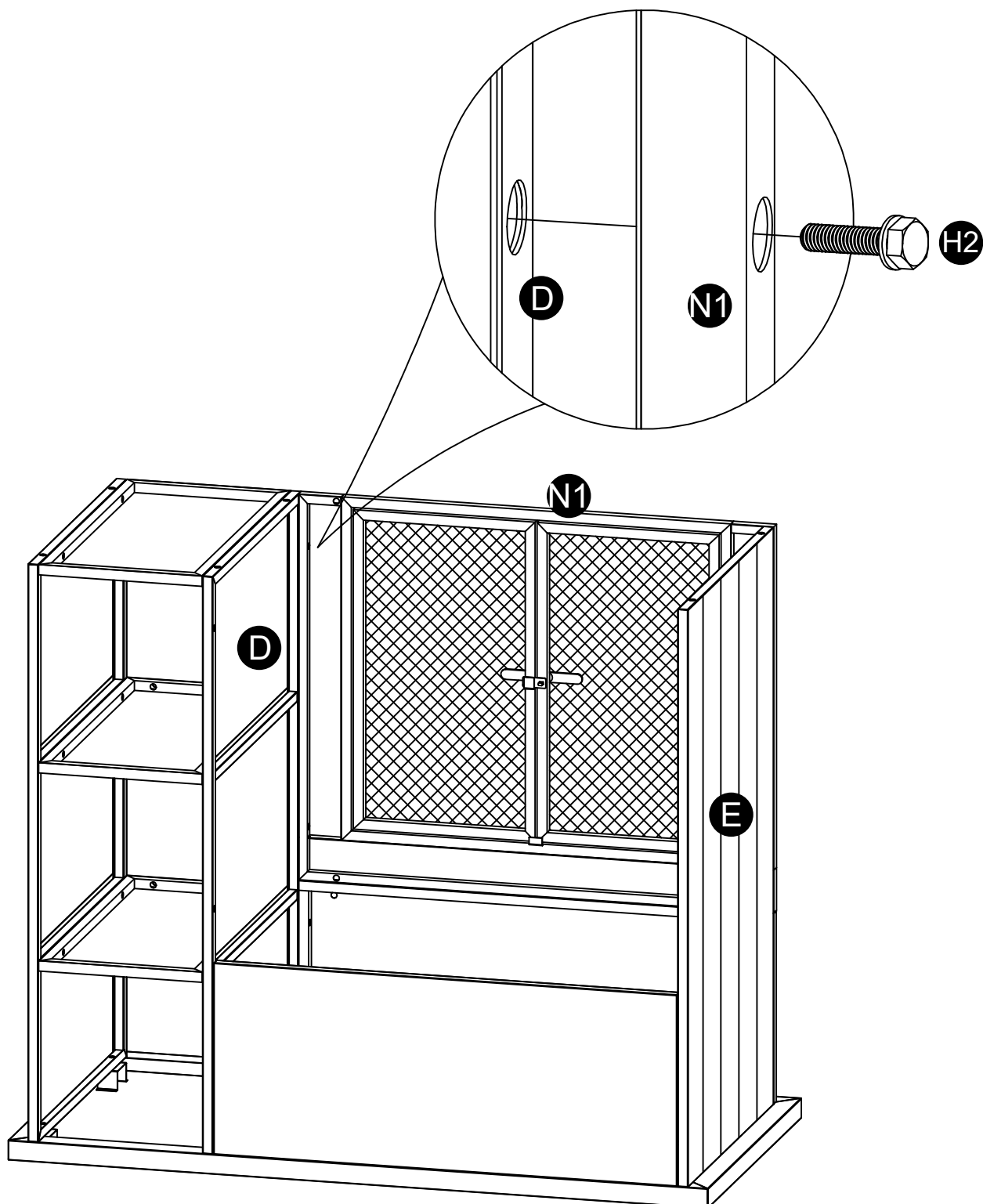
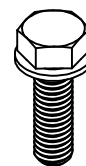
**H2**

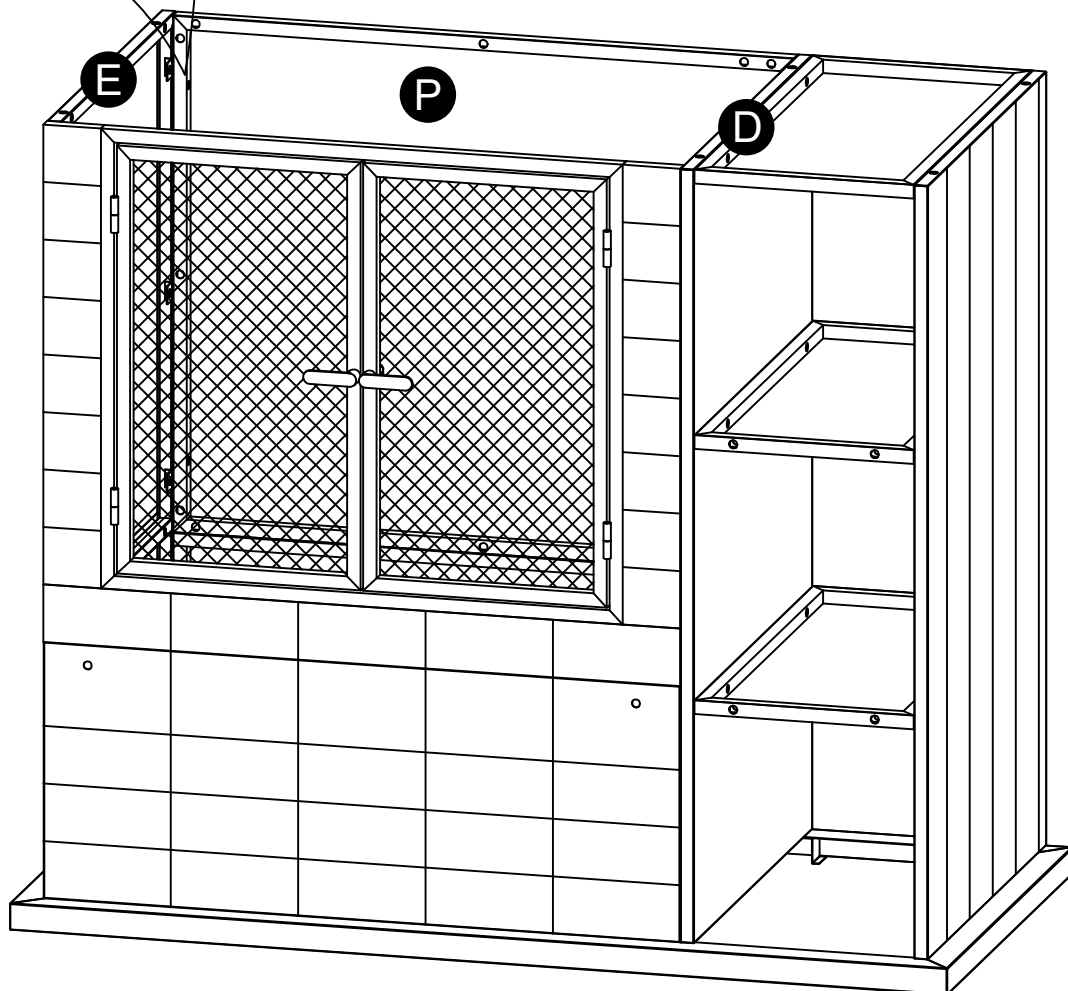
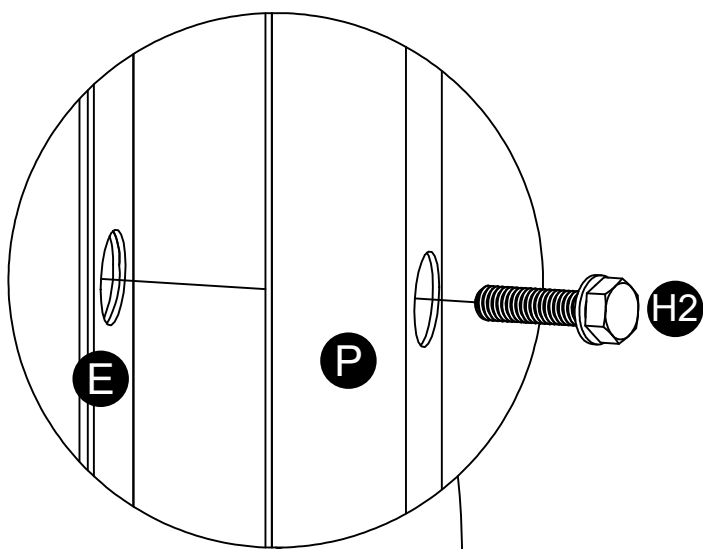
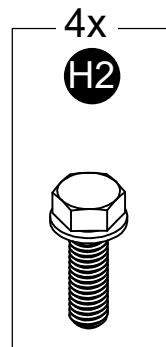
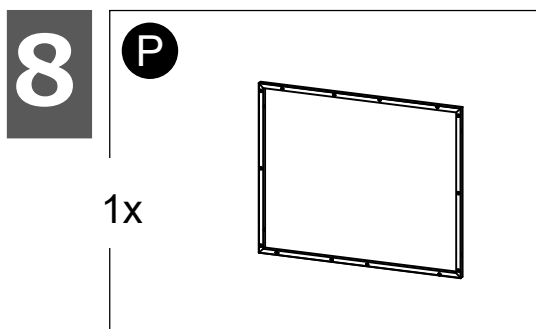

12x

H1



9

Q

1x

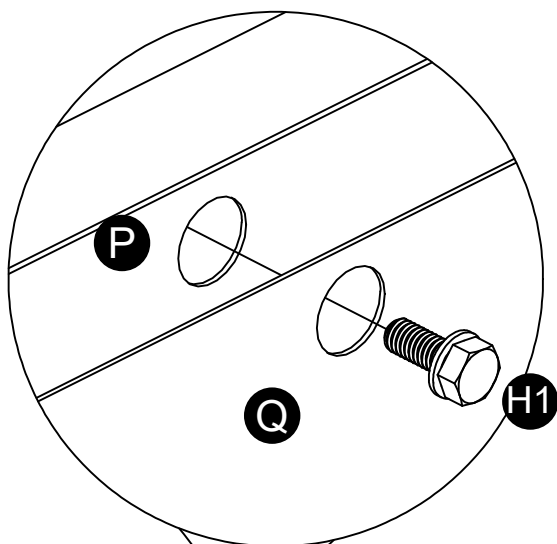
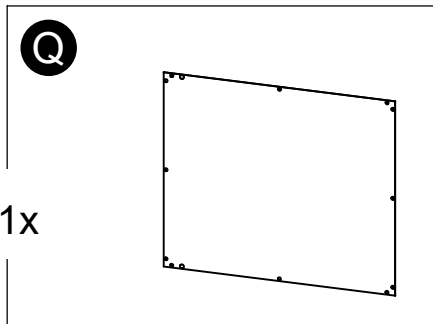

Note: The upper and lower holes in this position need no assembly bolts for the next assembly/  
 Remarque : Les trous supérieur et inférieur dans cette position ne nécessitent aucun boulon d'assemblage pour l'assemblage suivant.

P

Q

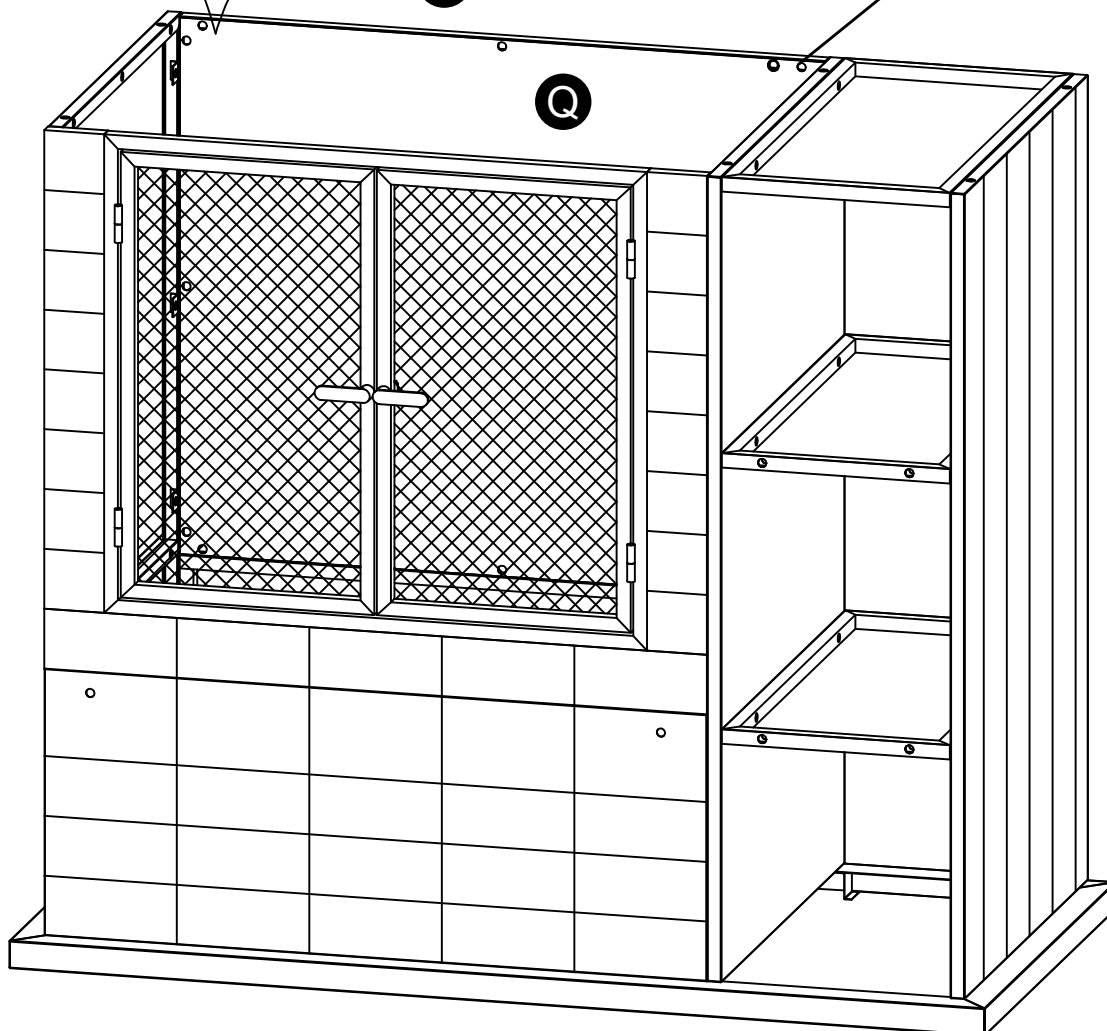

**10**

**R**

1x

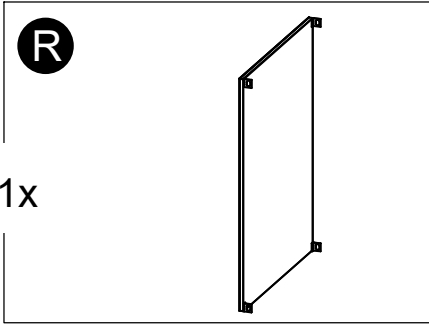

4x

**H1**

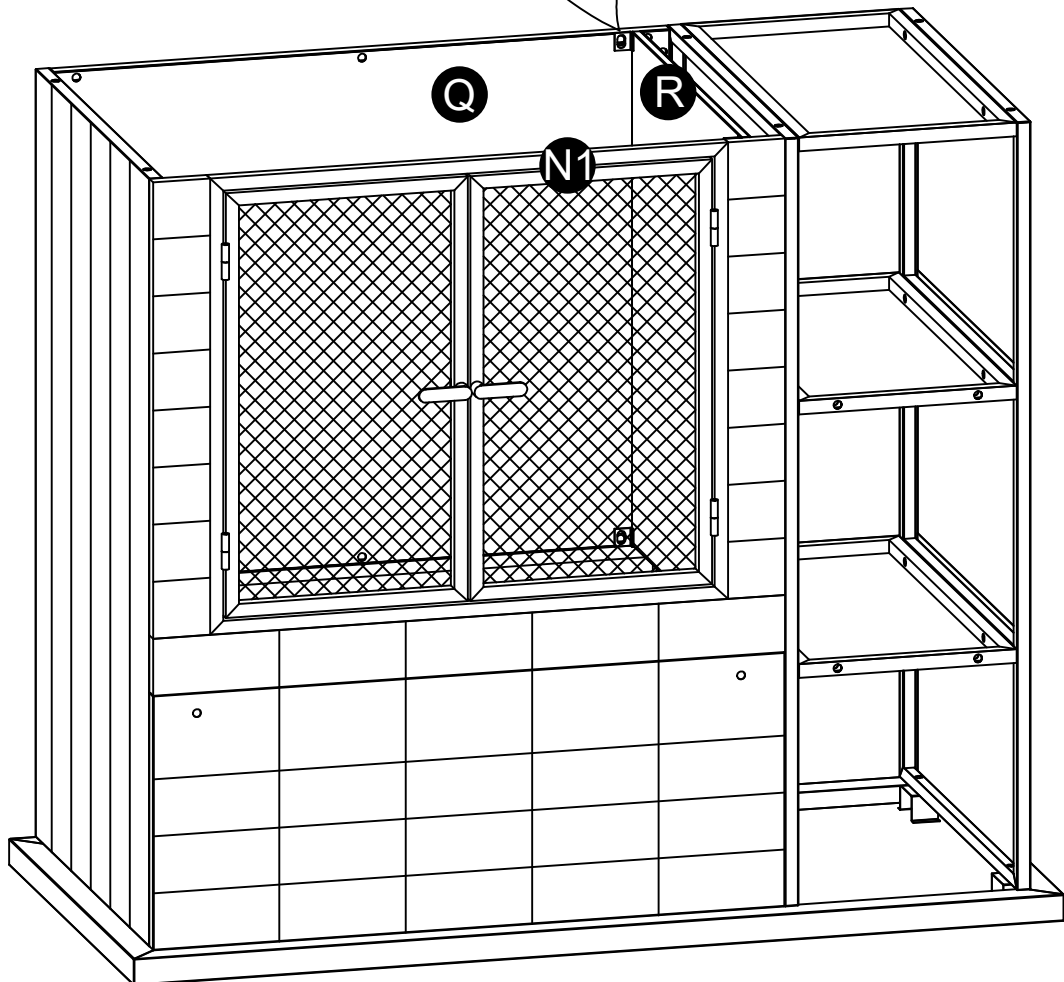
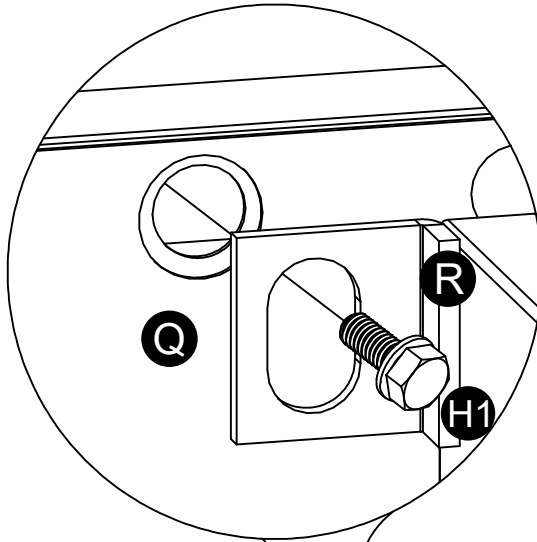
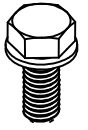

**11**

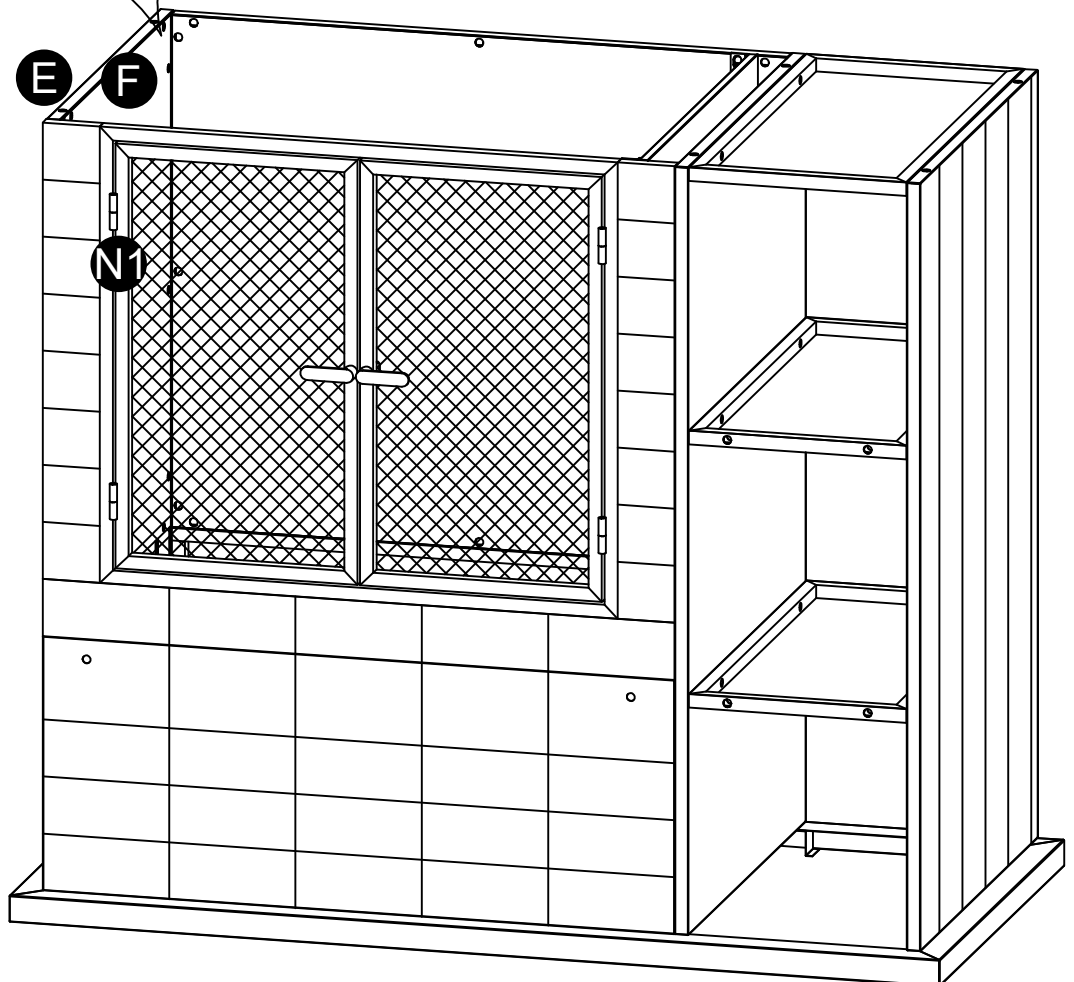
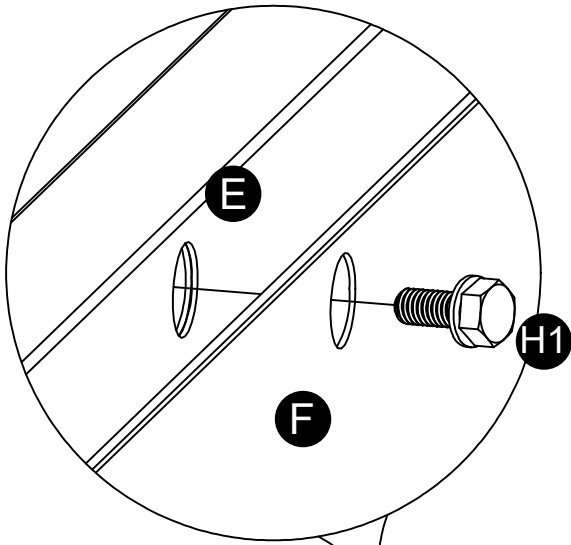
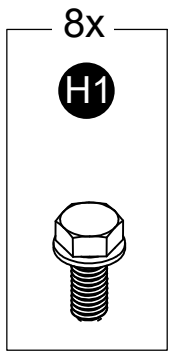
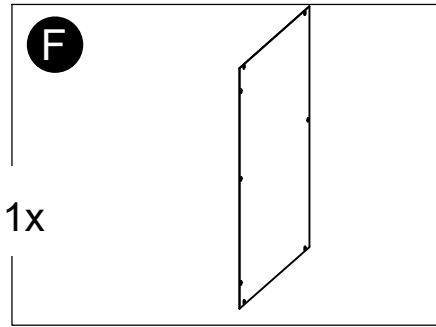

12

J

1x



4x

H1

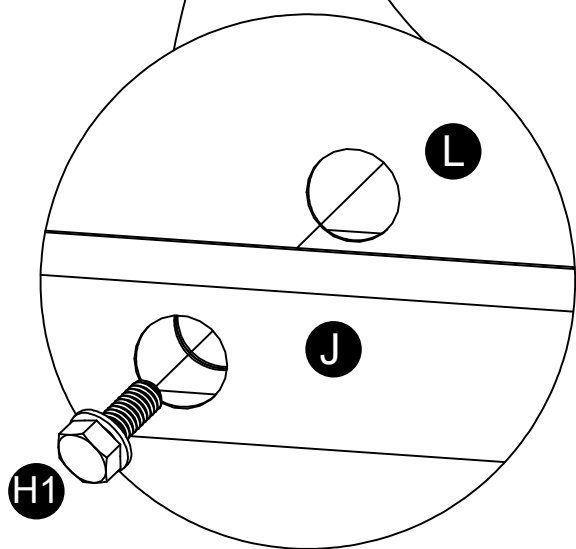
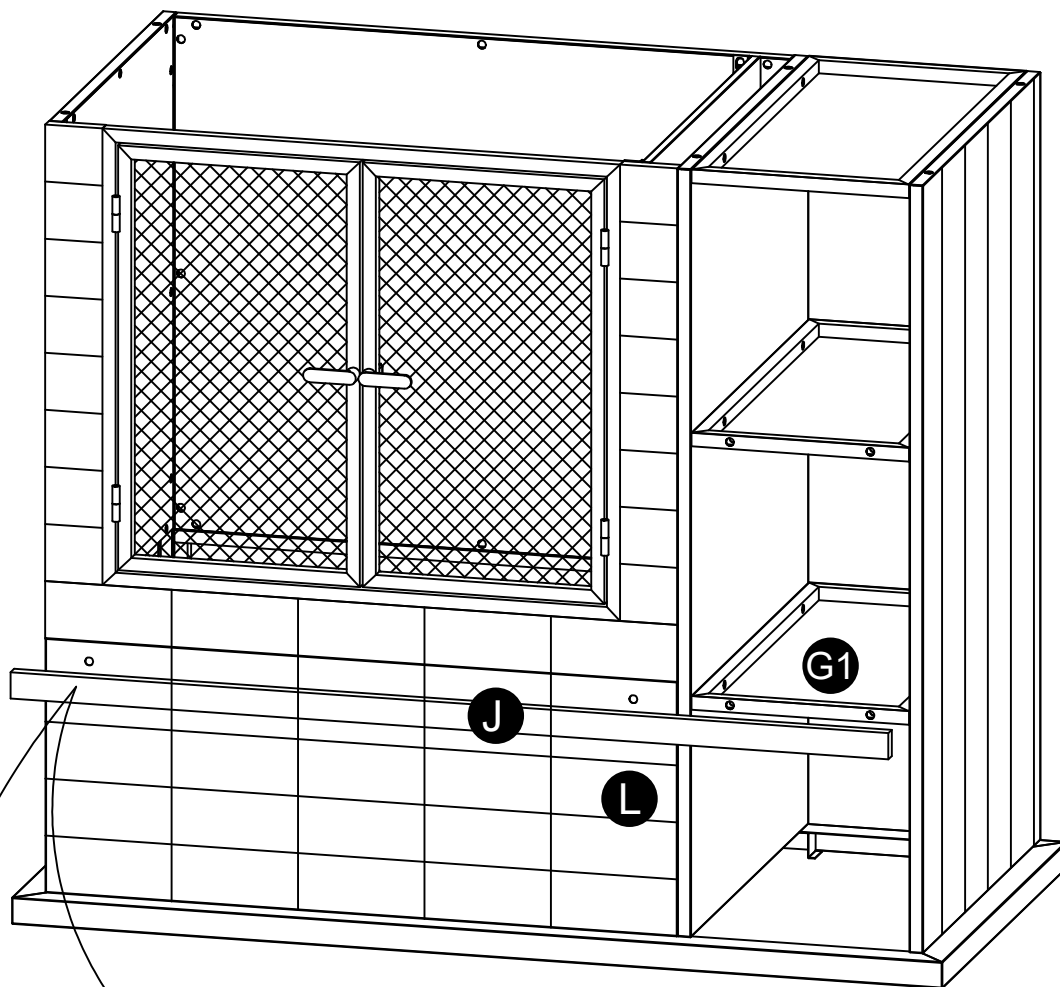
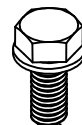

**13**

**K**

1x



2x

**H1**

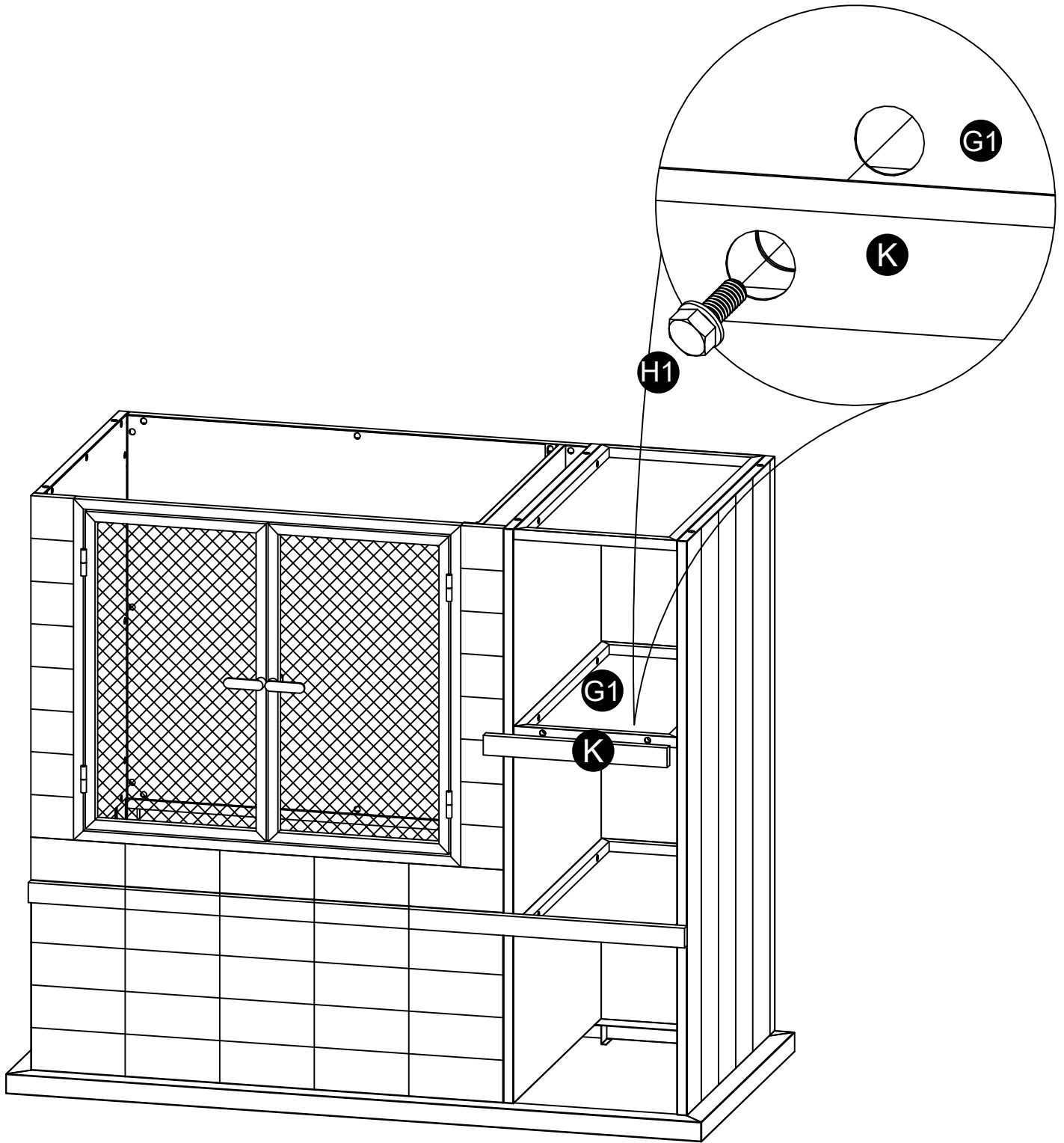
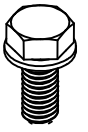

14

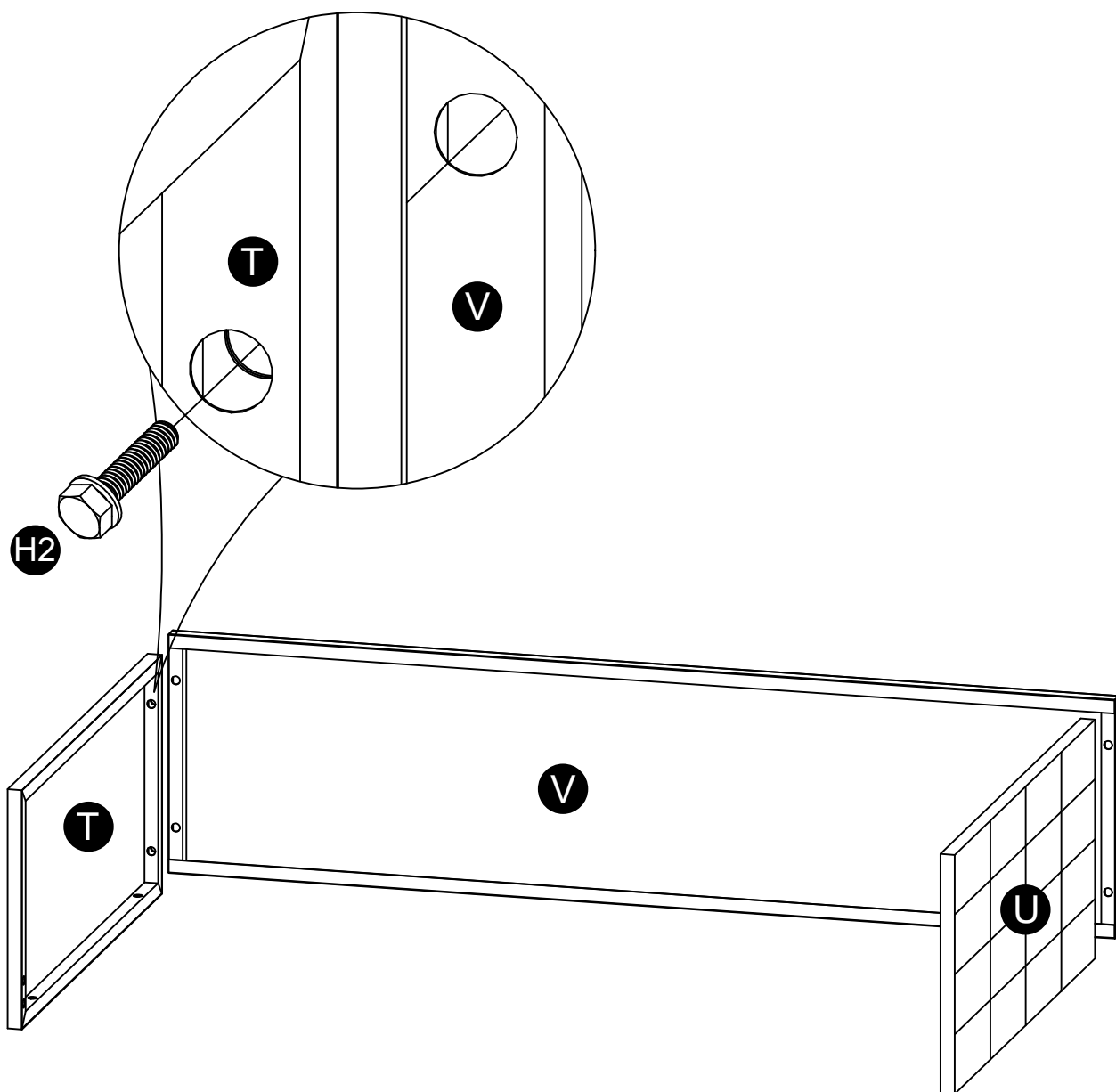
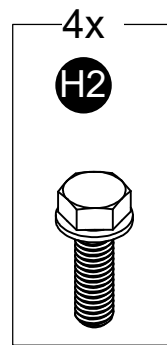
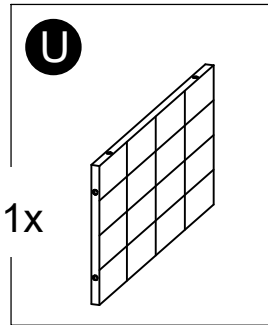
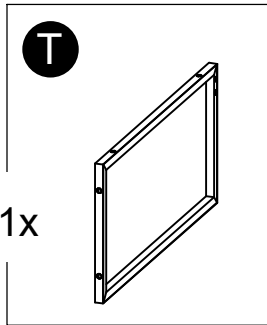
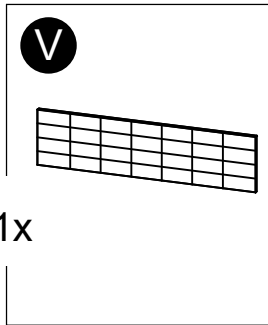

15

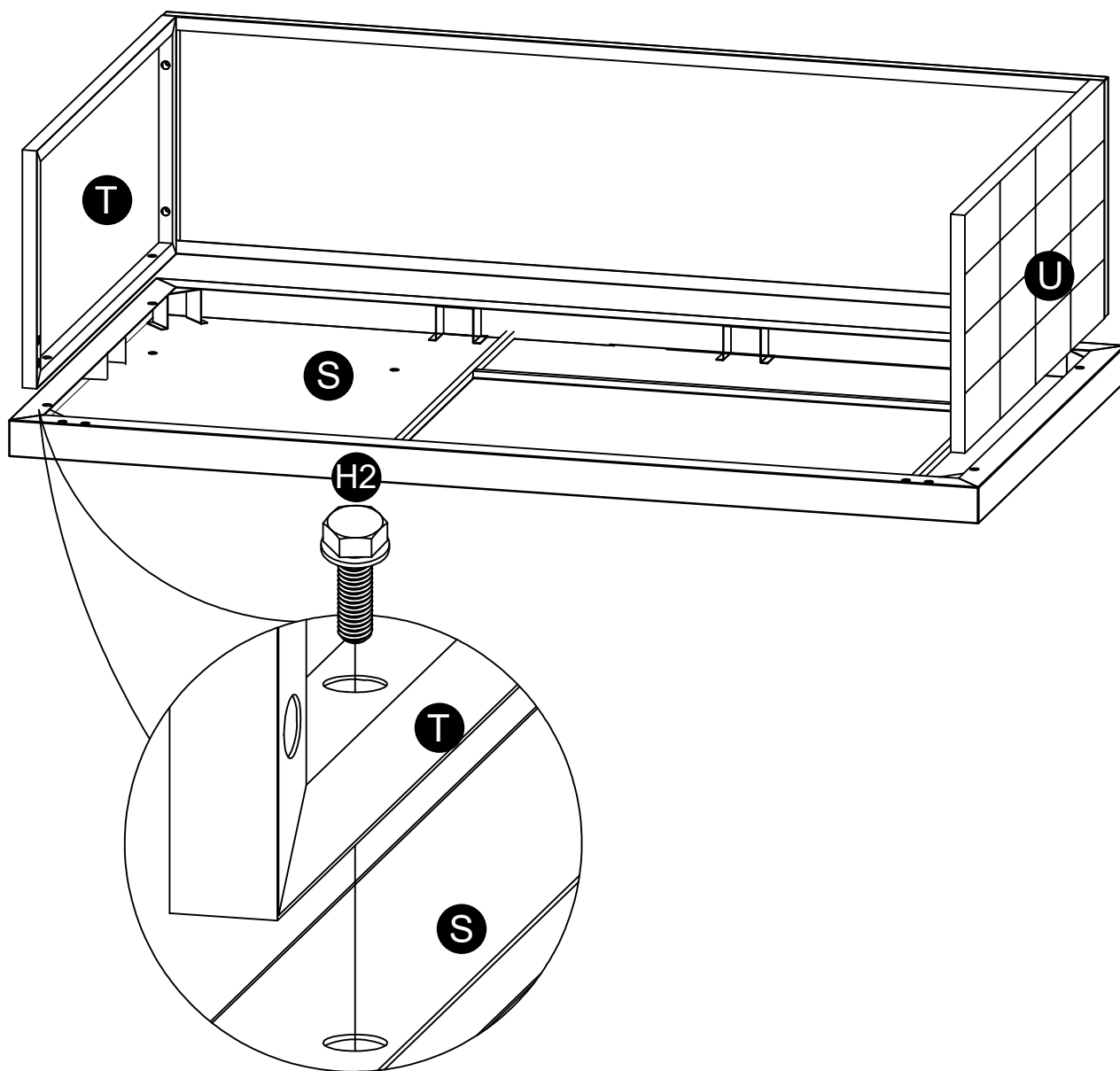
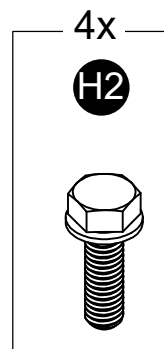
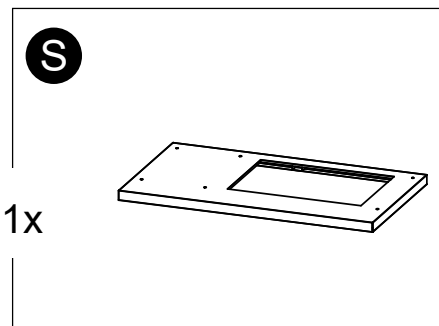

**16**

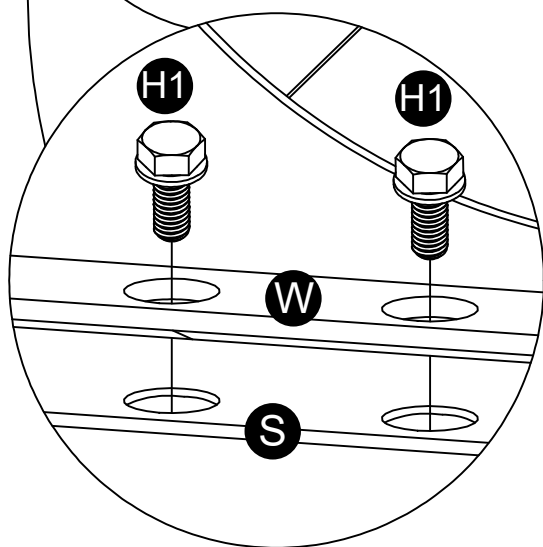
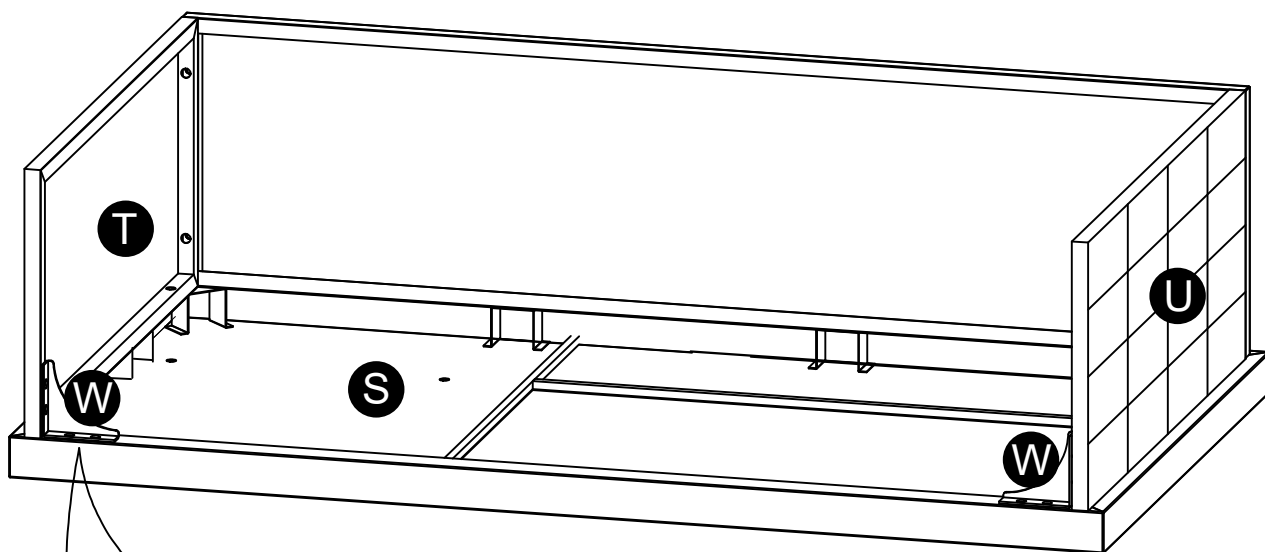
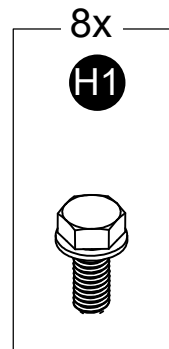
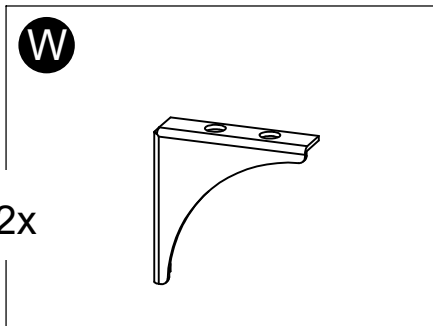

# 17

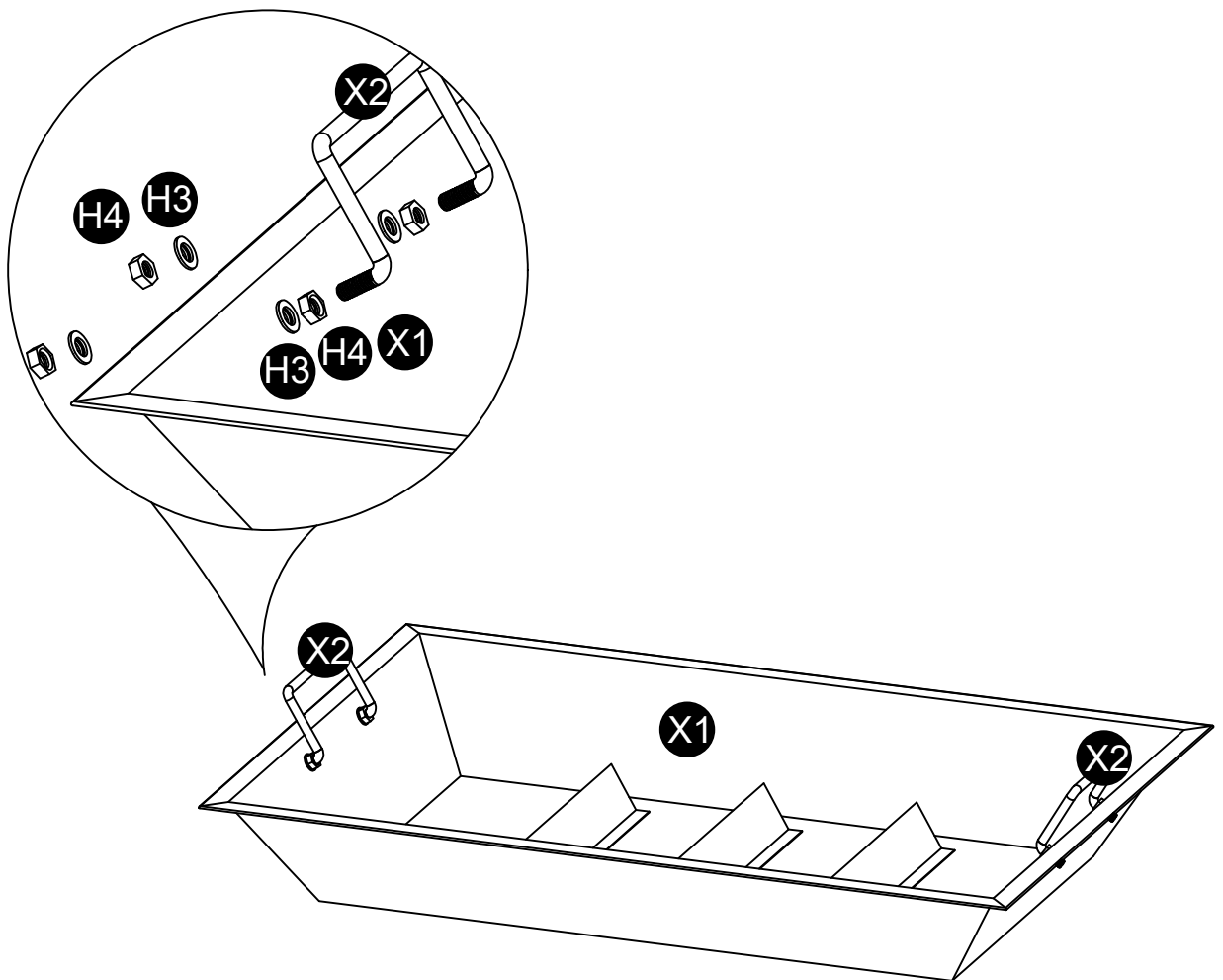
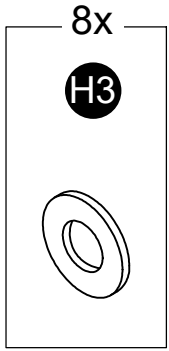
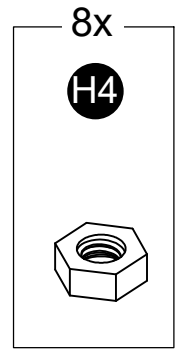
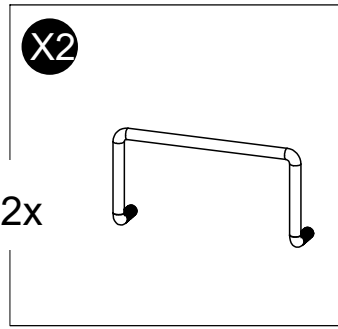
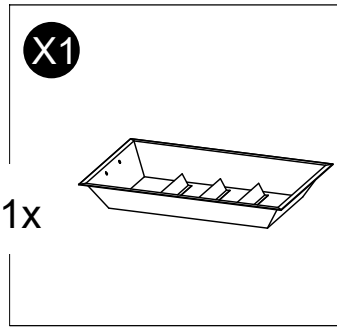

18

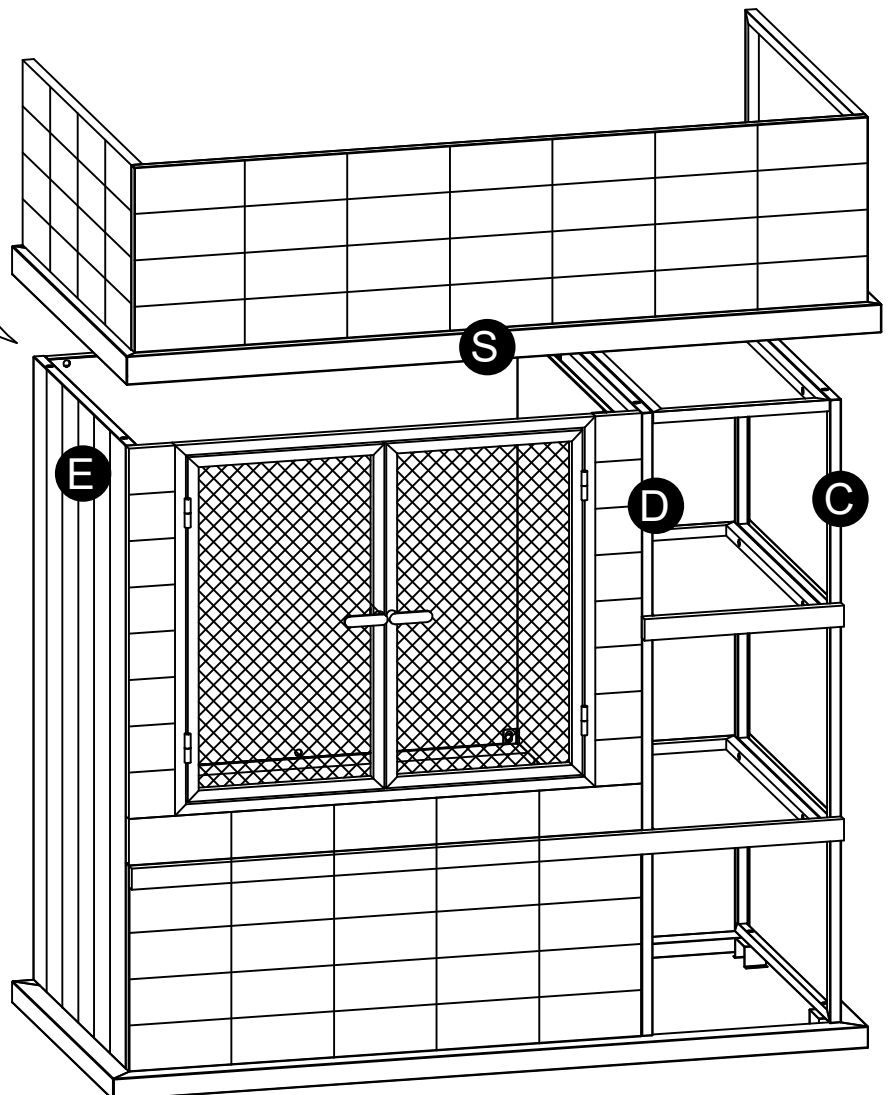
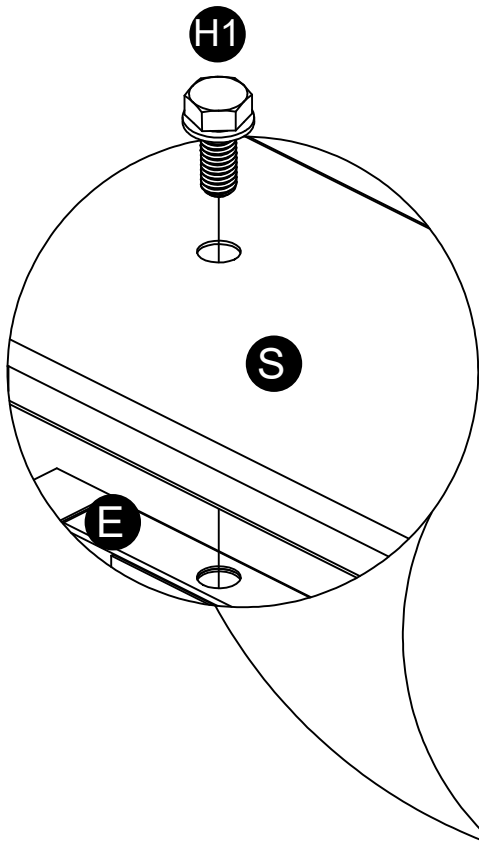
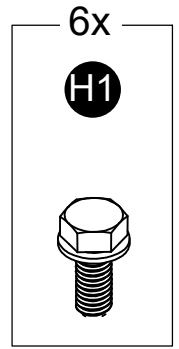

19

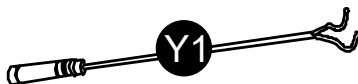
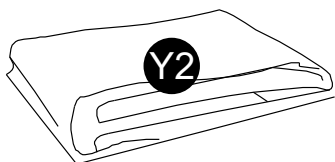
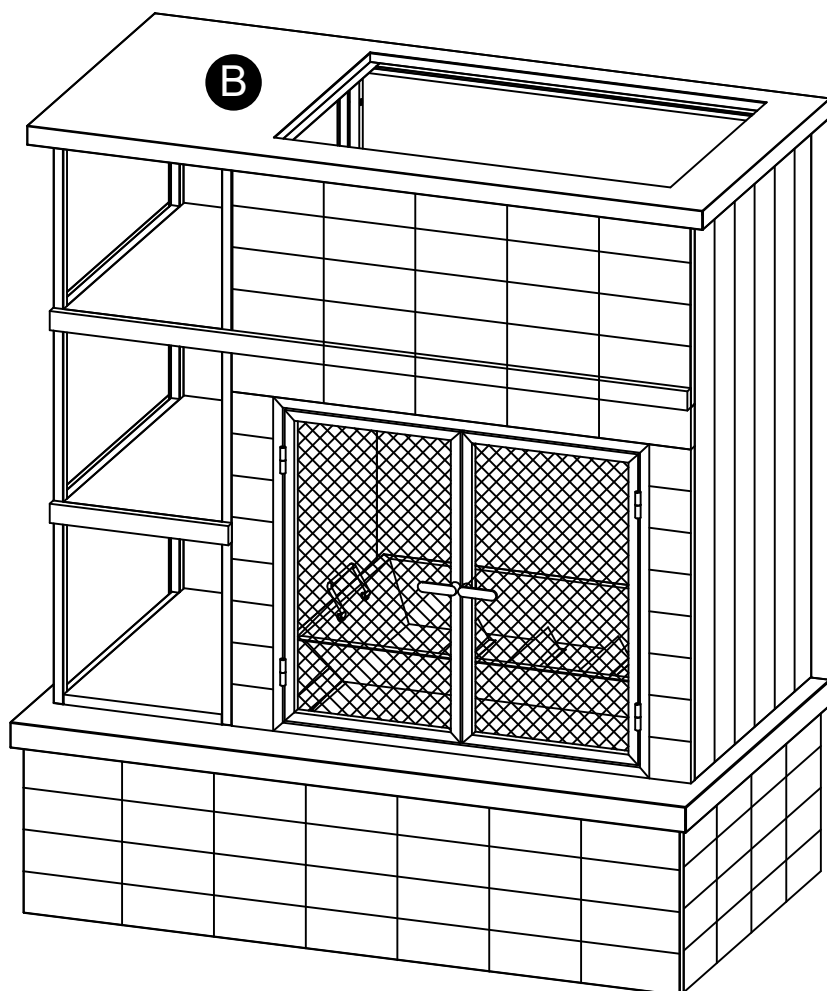
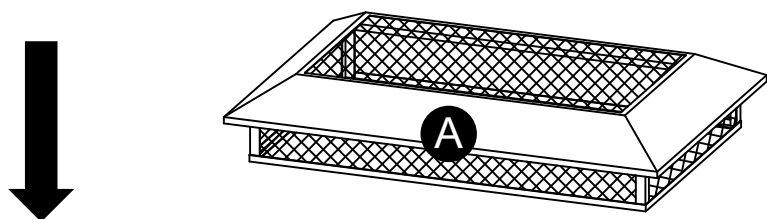
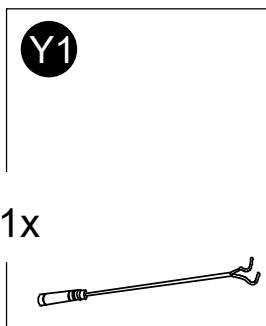
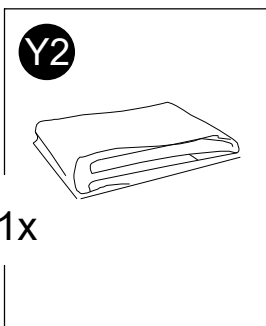
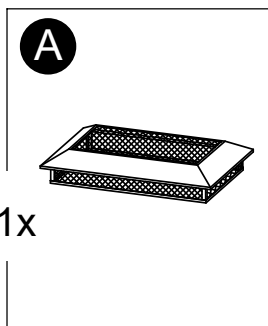

## **Care & Maintenance**

Before using, clean the fireplace completely with a soft dry towel. When not in use, wipe free of any dirt or loose objects, wash with a mild solution of soap and water; rinse thoroughly and dry completely. Do not use strong detergent or abrasive cleaners. When not in use, recommend the use of patio furniture covers.

Steel components of garden accessories and furniture are treated with rust inhibiting paint. However, due to the nature of steel, surface oxidation (rusting) will occur if this protective coating is scratched. To minimize this condition, it is recommended that care be taken when assembling and handling the product, in order to prevent the paint from being scratched.

Like all topical coatings, cleaning should be with a non-abrasive neutral pH cleaner.

## **Limited Warranty**

We warrant to the original purchaser that this item is free from defects in workmanship and materials for a period of (1) year from the date of purchase, provided the item was factory-sealed at the time of purchase and is maintained with care and used only for personal, residential purposes. Should any manufacturing defect arise within this warranty period, we will repair or replace (at our option) any defective merchandise upon proof of purchase; however, transportation and delivery costs, as well as payments to a third party for assembly or disassembly of the item, remain the responsibility of the purchaser. A purchaser of an "open box," previously-returned, or "clearance" item, as well as original purchasers outside of the warranty period, may obtain replacement parts from us for products in current production, at nominal cost.

## **Exclusions**

Items used for commercial, contract, or other non-residential purposes, or items damaged due to acts of nature, vandalism, misuse, or improper assembly are not covered. Corrosion or rusting of hardware is not covered. Proof of purchase (dated register receipt) is required for warranty claims. Warranty is to the original purchaser and is non-transferable. Any replacement of warranted items will be in the original style and color, or a similar style and color if the original is unavailable or has been discontinued. As some states do not allow exclusions or limitations on an implied warranty, the above exclusions and limitations may not apply. This warranty gives you specific rights, and you may also have other rights, which vary from state to state.

## **Soin et Entretien**

Avant d'utiliser, nettoyez le produit complètement avec une serviette sèche et douce. Tandis que l'on ne l'utilise pas, nettoyez toute saleté ou objets, lavez avec une solution légère d'eau et de savon, rincez et séchez complètement.

N'utilisez pas de détergents forts ou de nettoyeurs abrasifs. Tandis que l'on ne l'utilise pas, nous recommandons de couvrir avec des housses pour mobilier de patio, ou une protection similaire (pas incluse).

Les accessoires et mobilier de jardin sont traités avec une peinture antirouille. Cependant, dû à la nature de l'acier, la rouille peut se produire si ces couches protectrices sont rayées.

Pour réduire ce problème, il est recommandé de faire très attention pendant le montage et la manipulation du produit, pour ne pas rayer ou égratigner la peinture.

## **Garantie Limitée du Fabricant**

garantit à l'acheteur d'origine que cet article est exempt de défauts de fabrication et de matériaux pour une période d'un an à compter depuis la date d'achat, pourvu que l'article soit scellé de fabrique au moment de l'achat et qu'il soit entretenu avec soin et utilisé uniquement à des fins personnelles et résidentielles. Si un défaut de fabrique se produit dans la période de garantie, réparera ou remplacera (à votre option) toute marchandise défective en montrant une preuve d'achat; cependant, les frais de transport et de livraison, autant que les paiements à d'autres personnes pour le montage ou démontage du produit, seront la responsabilité de l'acheteur. Un acheteur d'une "boîte ouverte", précédemment rendue, ou article en "liquidation", autant que les acheteurs original hors de la période de garantie, peuvent obtenir des pièces de remplacement de pour les produits qui sont couramment sous production, à un prix abordable.

## **Exclusions**

Les articles utilisés pour emploi commercial, sous contrat, ou d'autres emplois non-résidentiels, ou les articles abimés par les intempéries, le vandalisme, le mauvais emploi, le montage incorrecte ne sont pas couverts. La corrosion ou la rouille de la quincaillerie ne sont pas couverts. Une preuve d'achat (reçu daté) sera requise pour toute réclamation sous garantie. La garantie est pour l'acheteur originel et n'est pas transmissible. Tout article de rechange garanti sera du style et de la couleur d'origine, ou d'un style ou couleur similaire si l'originel n'est pas disponible ou s'il a été discontinué. Comme certains états ne permettent pas d'exclusions ni de limitations sur une garantie implicite, les exclusions et limitations ci-dessus peuvent ne pas s'appliquer. Cette garantie vous donne des droits spécifiques et vous pourriez également avoir d'autres droits, qui varient d'un état à un autre.