

Nightstands

Table de chevet

Nachttisch

Comodino

Mesilla de noche

협탁

ナイトスタンド

床头柜

B200980N

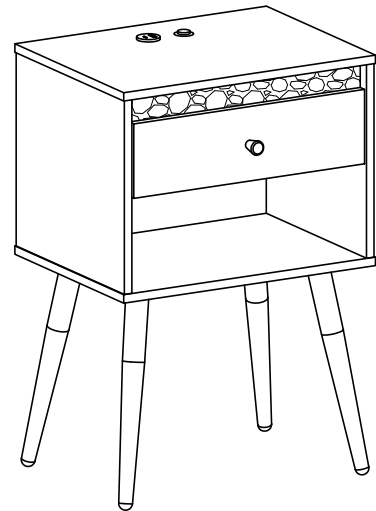
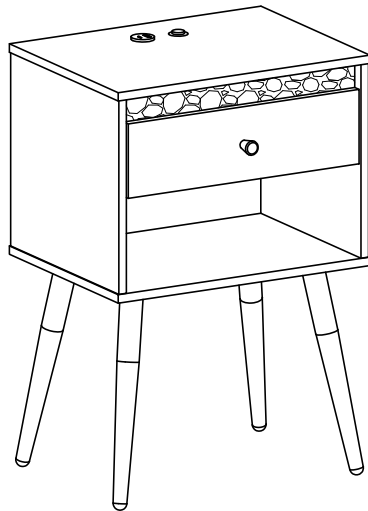

B200940M

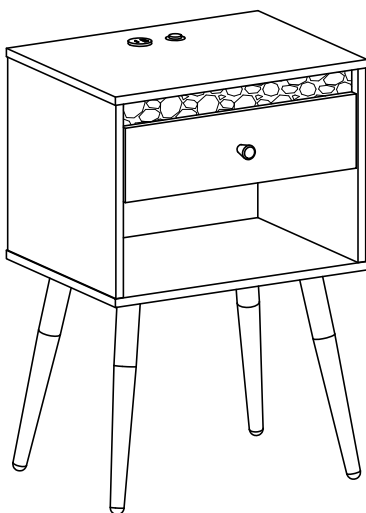

ASSEMBLY INSTRUCTION

Montageanleitung

Instructions De Montage

Istruzioni Per L'assemblaggio

Instrucciones De Montaje

어셈블리 설명

組立説明書

安装说明书



HELPFUL HINTS

BEFORE YOU START

Inspect product packaging to ensure the appearance is good.

Read the assembly instruction carefully and follow it step by step.

To avoid any scratching, putting a soft blanket on the floor is suggested.

Identify, sort and count all the parts with tags.

Find out installation position according to the drawing and install it in correct steps.



OTHER

- People needed for assembly: 1-2.
- Estimated assembly time: 0.5-1h.

CAUTION

Be cautious when using a power drill or power screwdriver.

Please be aware to slow down and stop when screw is nearly tight.

Do Not use any harsh chemicals or abrasive cleaners for this item.

Push, pull or drag this item carefully.

ASTUCES UTILES

AVANT DE COMMENCER

Inspectez l'emballage du produit pour vous assurer que l'apparence est bonne.

Lisez attentivement les instructions de montage et suivez-les étape par étape.

Pour éviter toute rayure, posez une couverture douce sur le sol est suggéré.

Identifiez, triez et comptez toutes les pièces avec des étiquettes.

Trouver la position d'installation selon le dessin et l'installer dans les étapes correctes.



AUTRE

- Personnes nécessaires pour l'assemblage : 1-2.
- Temps de montage estimé : 0.5-1 h.

AVERTIR

Soyez prudent lorsque vous utilisez une perceuse électrique ou un tournevis électrique.

Veuillez être conscient de ralentir et d'arrêter lorsque la vis est presque serrée.

N'utilisez pas de produits chimiques corrosifs ou de nettoyeurs abrasifs pour cet article.

Poussez, tirez ou tirez cet article avec précaution.

CONSEJOS ÚTILES

ANTES DE EMPEZAR

● Inspeccione el paquete del producto para asegurarse de que la apariencia es buena.

● Lea atentamente las instrucciones de montaje y sígalas paso a paso.

● Para evitar rayas, se sugiere poner una manta suave en el suelo.

● Identifique, clasifique y enumere todas las piezas con etiquetas.

● Averigüe la posición de instalación según el dibujo e instálela en los pasos correctos.



OTROS

- Personas necesarias para el montaje: 1-2.
- Tiempo de montaje estimado: 0.5-1 h.

PRECAUCIÓN

● Tenga cuidado al utilizar un taladro eléctrico o un destornillador eléctrico.

● Tenga en cuenta que debe hacerlo más despacio y detenerse cuando el tornillo esté casi apretado.

● No utilice productos químicos agresivos ni limpiadores abrasivos para este artículo.

● Empuje, tire o arrastre este elemento con cuidado.

SUGGERIMENTI UTILI

PRIMA DI INIZIARE

● Controllare la confezione del prodotto per assicurarsi che sia in buono stato.

● Leggere con attenzione le istruzioni per l'assemblaggio e seguirle passo dopo passo.

● Per evitare graffi al pavimento, suggeriamo di stendervi una coperta morbida.

● Identificare, suddividere e contare tutte le parti con etichetta.

● Trovare la posizione adatta per il montaggio in base al disegno e montare lo scaffale seguendo correttamente i vari passaggi.



ALTRO

- Persone necessarie per l'assemblaggio: 1-2.
- Tempo di assemblaggio stimato: 0.5-1 ora.

ATTENZIONE

● Prestare molta attenzione quando si utilizza un trapano elettrico o un cacciavite elettrico.

● Rallentare con accortezza e fermarsi quando una vite è già sufficientemente serrata.

● Non utilizzare prodotti chimici aggressivi o detergenti abrasivi su questo articolo.

● Spingere, tirare o trascinare questo articolo con cautela.

NÜTZLICHE HINWEISE

BEVOR SIE BEGINNEN

- Überprüfen Sie die Produktverpackung auf Schäden.
- Lesen Sie sich die Montageanleitung sorgfältig durch und befolgen Sie sie Schritt für Schritt.
- Um etwaiges Zerkratzen zu vermeiden, wird das Auslegen einer weichen Decke auf dem Boden empfohlen.
- Identifizieren, sortieren und zählen Sie alle Teile mit Tags nach.
- Identifizieren Sie die Montageposition gemäß der Zeichnung und bauen Sie das Regal den richtigen Schritten entsprechend auf.

SONSTIGES

- Für den Zusammenbau erforderliche Anzahl an Menschen: 1-2.
- Ungefähre Montagedauer: 0.5-1 h.

VORSICHT

- Seien Sie bei der Verwendung einer Bohrmaschine oder eines Akkuschraubers vorsichtig.
- Bitte vergessen Sie nicht darauf, langsamer zu werden und zu stoppen, sobald die Schraube fast festgezogen ist.
- Verwenden Sie keinerlei aggressive Chemikalien oder scheuernden Reinigungsmittel für dieses Produkt.
- Schieben oder ziehen Sie dieses Produkt vorsichtig.

유용한 힌트

시작하기 전에

- 제품 포장 검사, 확보외관이 좋다.
- 어셈블리 지침 자세히 보기한 걸음 한 걸음 그것을 따르다.
- 굽히지 않도록 바닥에 부드러운 담요를 놓는 것이 좋습니다.
- 모든 부품을 라벨로 식별, 분류 및 계산합니다.
- 도면에 따라 설치 위치를 찾아 올바른 단계에 따라 설치합니다.

기타

- 조립에 필요한 인원: 1-2명.
- 예상 조립 시간: 0.5-1h.

안전에 주의하다:

- 전기 드릴이나 전기 드라이버를 사용할 때는 조심해야 한다.
- 나사가 거의 조이면 속도를 줄이고 멈추십시오.
- 자극성 화학물질이나 연마성 세정제는 이 품목에 사용하지 마십시오.
- 이 항목을 조심스럽게 밀거나 당기거나 드래그합니다.

役に立つヒント

組立の場所を確保し、順番通りに組み立てる

- 組立場所 (充分広くて平たい場 所) を確保してください。
- 床や壁、商品を傷つけないように、商品の下に厚めの布や段ボールなどを敷いてください。
- 組立の順番を守らないと、組立できなくなったり、商品を傷つけたりします。

その他

- 組み立てに必要な人:1-2.
- 組立時間: 約0.5~1時間.

部品を確認する

- ネジ類などの部品番号、形状を説明書の部品一覧で確認してください。
- 部品をなくさないように纏めて置いてください。
- 部品を取り出すときに使う分だけ取り出してください。

温馨提示

安装前注意事项

- 检查产品包装，确保外观良好。
- 仔细阅读安装说明，按步骤操作。
- 为了避免刮伤，建议在地板上放一条柔软的毯子。
- 标识、分类和清点所有部件。
- 根据图形找到安装孔位，按正确步骤安装。

其他:

- 组装所需人员:1-2人.
- 预计组装时间: 0.5-1小时.

注意:

- 小心使用电钻或电动螺丝刀。
- 当螺丝快要拧紧时，请注意减速。
- 不要使用任何刺激性化学物质或擦洗剂。
- 当推、拉或拖动产品时，注意小心谨慎，防止损坏。

DETAILS

DÉTAILS/POINTS DE MONTAGE
NOTE PARTICOLARI
DETALLES

디테일
組み立てのポイント
詳細情報

UNIT:INCH/CM/厘米

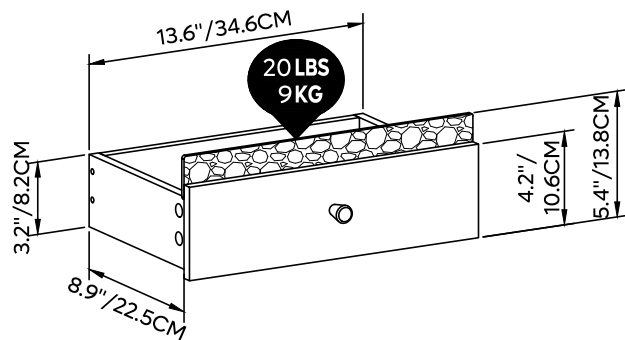
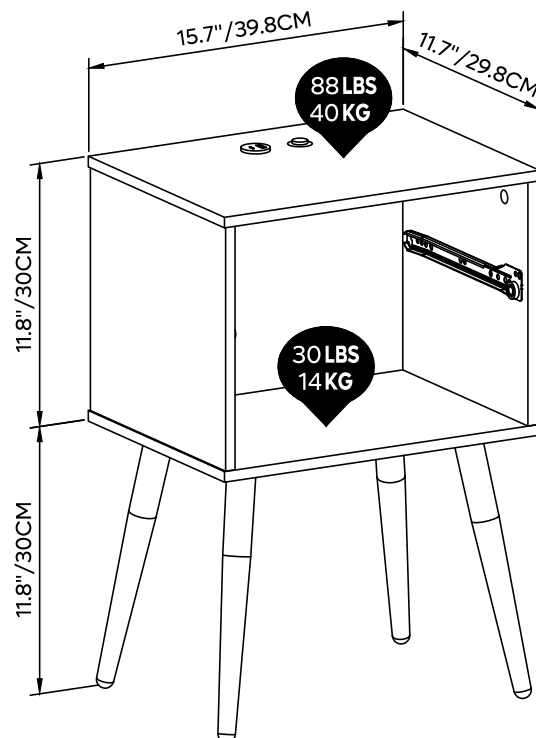
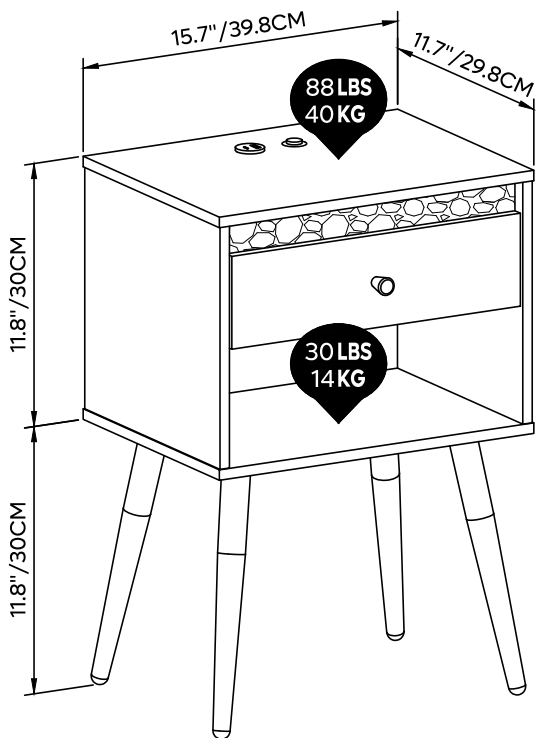

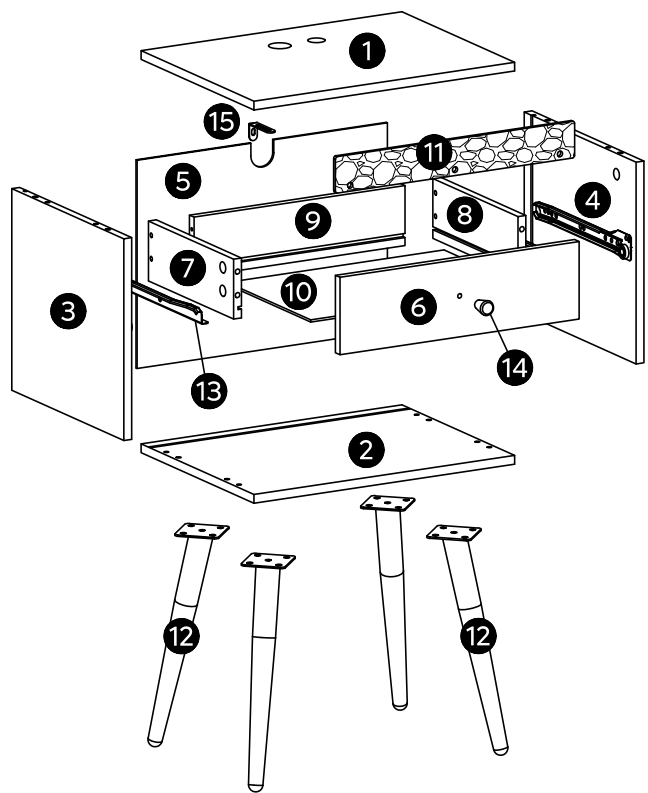
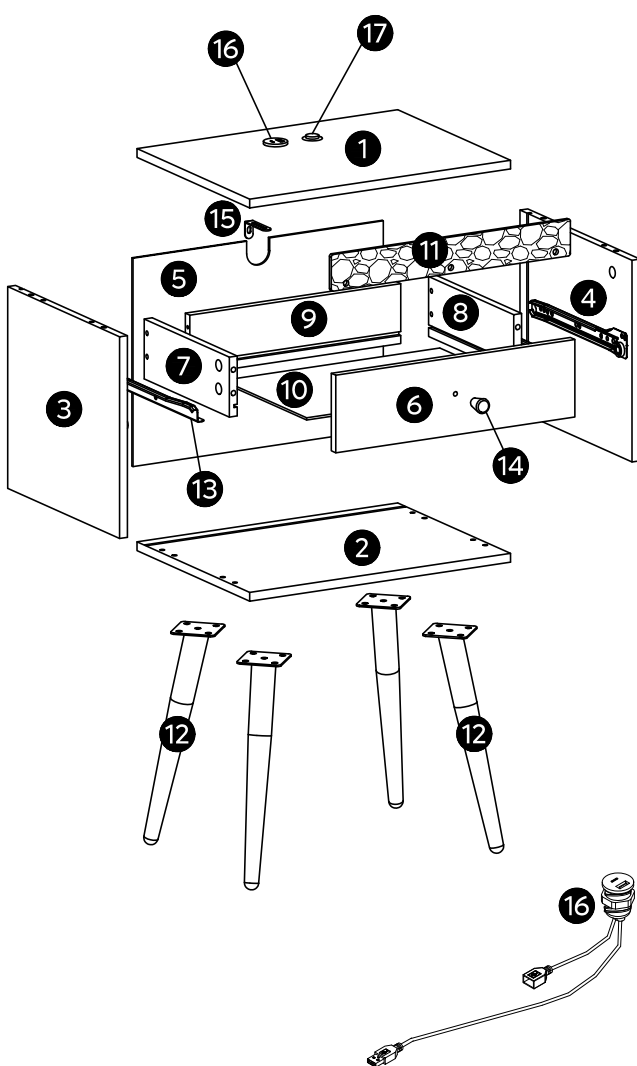

011-300LED

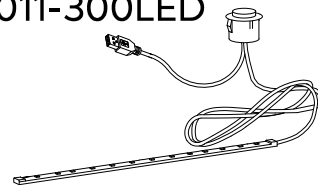

B200940M

PART LIST

STÜCKLISTE
LISTE DES PIÈCES
ELENCO DEI PEZZI

LISTA DE PIEZAS
부품 목록
部品の確認/部件清單

1

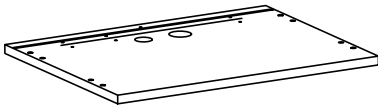

X1

2

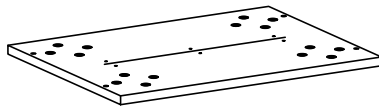

X1

3

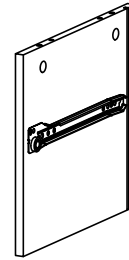

X1

4

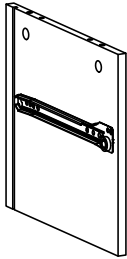

X1

5

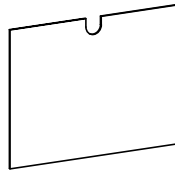

X1

6

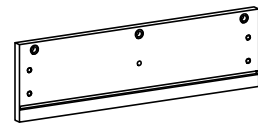

X1

7

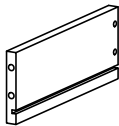

X1

8

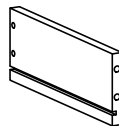

X1

9

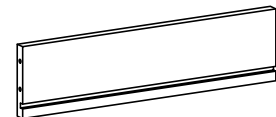

X1

10



X1

11

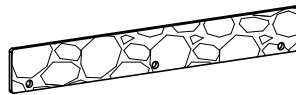

X1

12

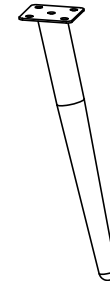

X4

13

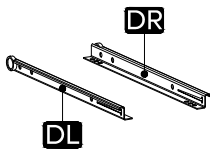

X1

14



X1

15

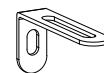

X1

16

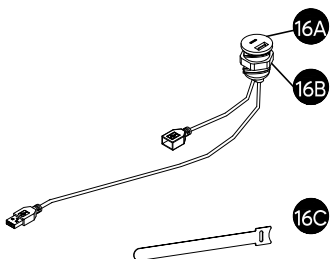

X1

17

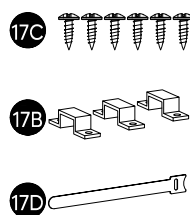

011-300LED

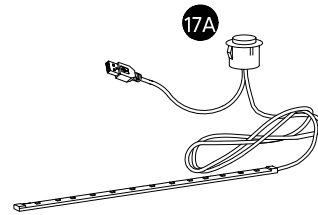







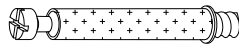

X1

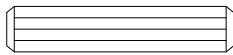
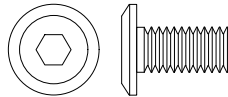
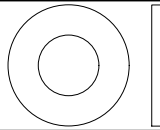
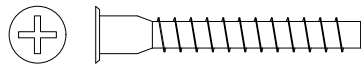
B200940M ACCESSORY LIST

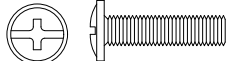
ZUBEHÖRLISTE
LISTE DES ACCESSOIRES
ELENCO DEGLI ACCESSORI

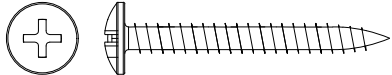
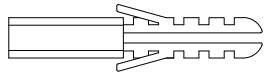
LISTA DE ACCESORIOS
부품 목록
付属品部品の確認/配件清單

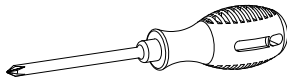
A	ST6x35mm	8+1	
B	Ø15	8+1	
C	Ø6x30mm	8+2	
D	M6x12mm	19+2	
E	Ø16mm	16+2	
F	ST5x35mm	8+1	
G	ST3x14mm	8+1	
H		4+1	
I	M4x16mm	1	
J	ST3.5x10mm	1	
K	ST4x35mm	1	
L	Ø8mm	1	
	M4	1	
		1	

B200980N

PART LIST

STÜCKLISTE
LISTE DES PIÈCES
ELENCO DEI PEZZI

LISTA DE PIEZAS
부품 목록
部品の確認/部件清單

1

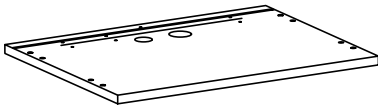

X2

2

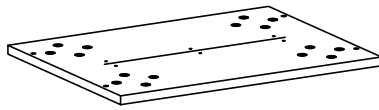

X2

3

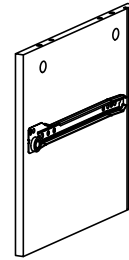

X2

4

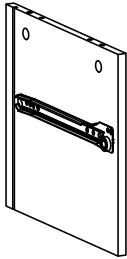

X2

5

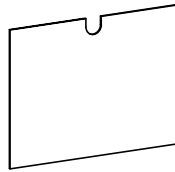

X2

6

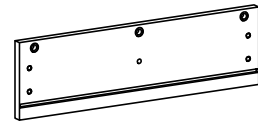

X2

7

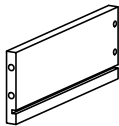

X2

8

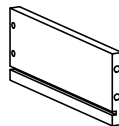

X2

9

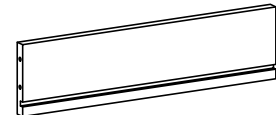

X2

10



X2

11

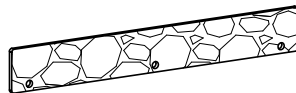

X2

12

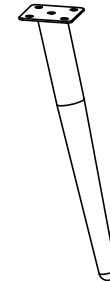

X8

13

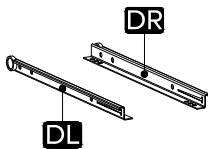

X2

14



X2

15

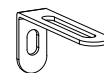

X2

16

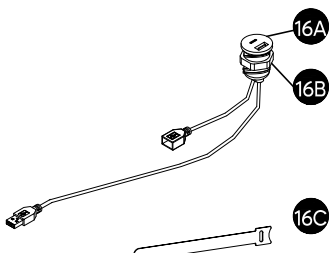

X2

17

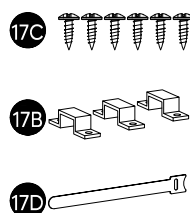

011-300LED

17A

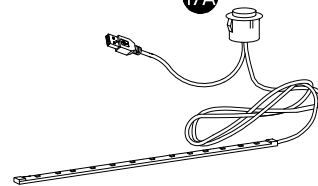





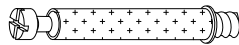

X2

B200980N ACCESSORY LIST

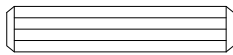
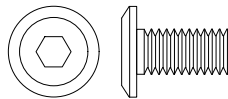
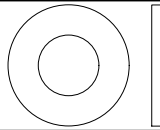
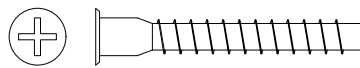
ZUBEHÖRLISTE
LISTE DES ACCESSOIRES
ELENCO DEGLI ACCESSORI

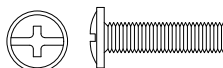
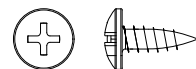
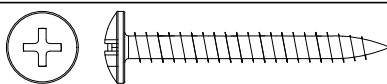
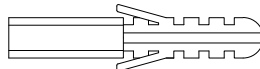
LISTA DE ACCESORIOS
부품 목록
付属品部品の確認/配件清單

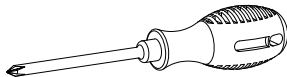
A	ST6x35mm	16+1	
B	Ø15	16+1	
C	Ø6x30mm	16+2	
D	M6x12mm	38+2	
E	Ø16mm	32+2	
F	ST5x35mm	16+1	
G	ST3x14mm	16+1	
H		8+1	
I	M4x16mm	2	
J	ST3.5x10mm	2	
K	ST4x35mm	2	
L	Ø8mm	2	
	M4	1	
		1	

Detailed Installation for Accessory A B

Installation détaillée pour l'accessoire A B
 Detaillierte Installation des Zubehörs A B
 Installazione dettagliata per l'accessorio A B
 Instalación detallada del accesorio A B
 액세서리 A 및 액세서리 B의 상세 설치
 カムロック取り付け方
 配件A、B详细安装

1

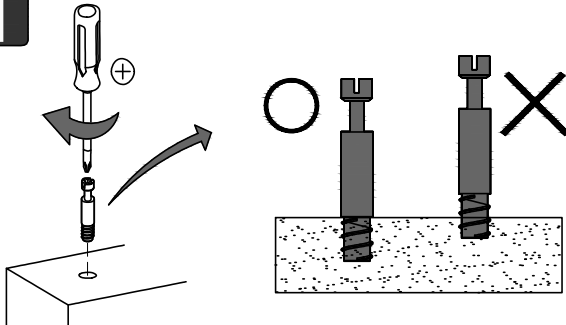

Screw cam dowel on the panel.
 Vissez la goupille de came au panneau.
 Nockendübel auf die Platte schrauben.
 Avvitare il tassello a camme sul pannello.
 tornillo de pasador de leva en el panel.
 캠 핀을 패널에 조입니다.
 カムロックネジを部品に取り付ける。
 螺杆用十字螺丝刀装入对应的预留孔内

Place another panel via the dowel.
 Placez un autre panneau par le goujon.
 Setzen Sie eine weitere Platte über den Dübel ein.
 Posizionare un altro pannello tramite il tassello.
 Coloque otro panel a través del pasador.
 핀을 통해 다른 패널을 배치합니다.
 カムロックネジをカムロック穴に差し込む。
 螺杆插入对应孔位，将两块板材对接起来。

2

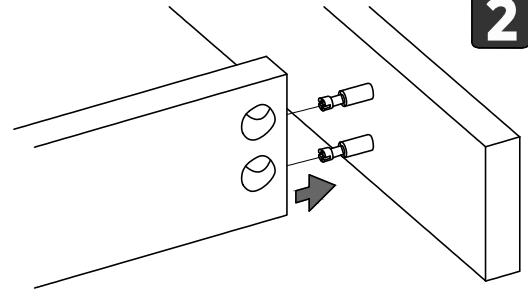

3

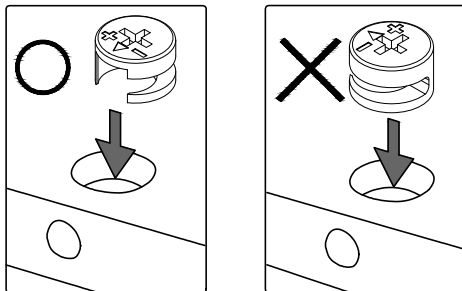

Pay attention to the direction of cam lock when putting it into hole.

Faites attention à la direction du verrou à came en entrant dans le trou.

Achten Sie auf die Richtung des Nockenschlosses, wenn Sie es in das Loch stecken.

Fare attenzione alla direzione della serratura a camme quando lo si inserisce nel foro.

Preste atención a la dirección de la leva de fijación al insertarla en el orificio.

캠 자물쇠를 구멍에 넣을 때 캠 자물쇠의 방향에 주의하십시오.

カムロックネジの方向にカムロックの穴の穴の向きを合わせ取り付け。

装入锁扣圆盘，注意锁扣圆盘的方向；

Tighten up cam lock clockwise until it stops.
 Serrez le verrou à came dans le sens des aiguilles d'une montre jusqu'à ce qu'il s'arrête.
 Ziehen Sie die Nockenverriegelung im Uhrzeigersinn bis zum Anschlag an.
 Stringere la serratura a camme in senso orario fino all'arresto.
 Apriete la leva de fijación en sentido horario hasta el tope.
 타이밍에 맞춰 캠 자물쇠가 멈출 때까지 조입니다.
 カムロックをドライバーで締め固定する。
 顺时针旋转锁扣圆盘并锁紧。

4

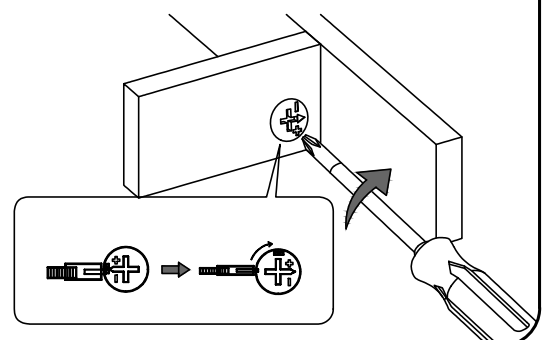

Detailed Installation for LED Strip

Installation détaillée de la bande LED
 Ausführliche Anbringungsanleitung für LED-Streifen
 Installazione dettagliata della striscia LED
 Instalación detallada de la tira de LED
 LED 밴드의 상세 설치
 LED 스트립라이트의設置に関する詳細説明
 LED 灯带安装方法

- 1**
- Remove about 25mm (1") of adhesive tape at both ends of LED light strip.
 - Retirez environ 25 mm de ruban adhésif à chaque extrémité de la bande lumineuse LED.
 - An beiden Enden des LED-Streifens etwa 25 mm (1 Zoll) des Klebebandes entfernen.
 - Rimuovere circa 25 mm di nastro adesivo su entrambe le estremità della striscia luminosa a LED.
 - Retire unos 25 mm (1") de la cinta adhesiva en ambos extremos de la tira de luces LED.
 - LED 램프의 양쪽 끝에서 약 25mm(1인치)의 테이프를 제거합니다.
 - LED 스트립라이트의 両端にある粘着テープを約25mm (1") はがしてください。
 - 揭开LED灯带两端的胶纸约25mm (1")。

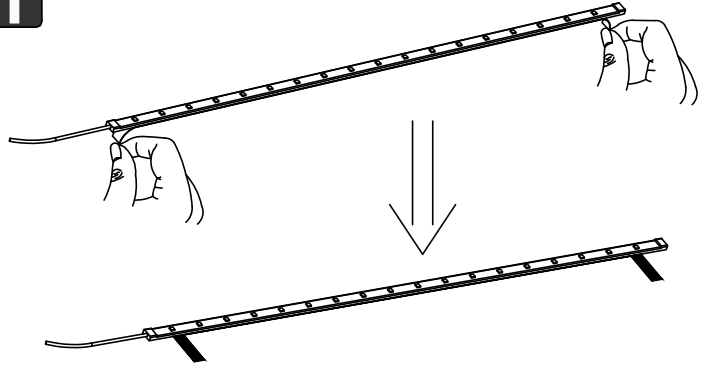

- 2**
- The head and tail of the LED light strip are pasted in a straight line, and the fixing parts at both ends are locked with screws.
 - Tête et queue du ruban LED collé sur une ligne droite, et les pièces de fixation situées à chaque extrémité sont sécurisées par des vis.
 - Kopf und Heck des LED-Lichtstreifens sind in einer geraden Linie geklebt und die Befestigungselemente anschrauben.
 - La testa e la coda della striscia luminosa LED sono incollati in un dritto Linea, e le parti di fissaggio ad entrambe le estremità sono bloccate con viti.
 - La cabeza y la cola del cinturón de Luz LED se pegan en línea recta Cable, las piezas de fijación en ambos extremos están cerradas con tornillos.
 - LED 램프의 머리와 꼬리는 일직선으로 붙여져 있고 양쪽 끝의 고정 부품은 나사로 단단히 잠겨 있습니다.
 - LED 라이트밴드의 頭部と尾部を直線に貼り付けるワイヤ、両端の固定具はネジでロックします。
 - LED灯带头尾沿着直线粘贴,用螺丝将两端的固定件锁住。

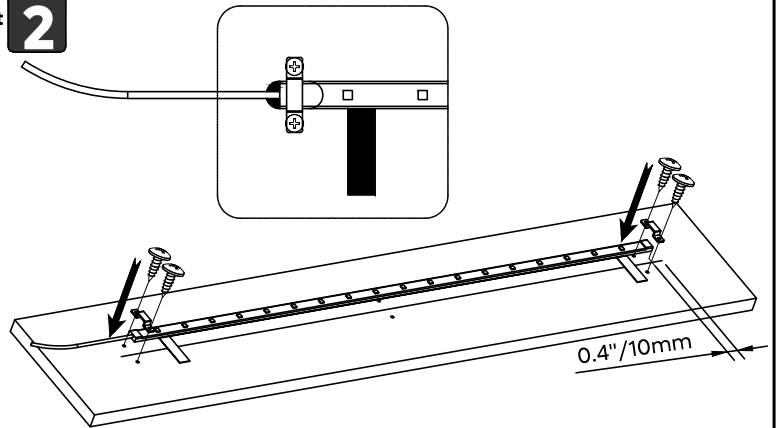

- 3**
- Tear off the whole protective paper, and flatten the strip light so that the LED light strip is completely adhered to the wood.
 - Arrachez tout le papier de protection et aplatissez la bande lumineuse de manière à ce que la bande lumineuse à DEL soit complètement collée au bois.
 - Die gesamte Schutzfolie abziehen und den LED-Streifen so flach andrücken, dass er vollständig auf dem Holz aufliegt.
 - Strappare l'intera carta protettiva e appiattire la striscia luminosa in modo da farla aderire completamente al legno.
 - Retire todo el papel protector y aplane la tira de luz para que la tira de luz LED quede completamente adherida a la madera.
 - 보호지 전체를 찢고 막대 램프를 눌러 LED 램프가 나무에 완전히 달라붙도록 합니다.
 - 全体の保護ペーパーをはがしてLED 스트립라이트を平らにして、木材に完全に貼り付けるようにします。
 - 将整条保护纸撕掉,并压平整条灯带,使LED灯带完全粘在木板上。

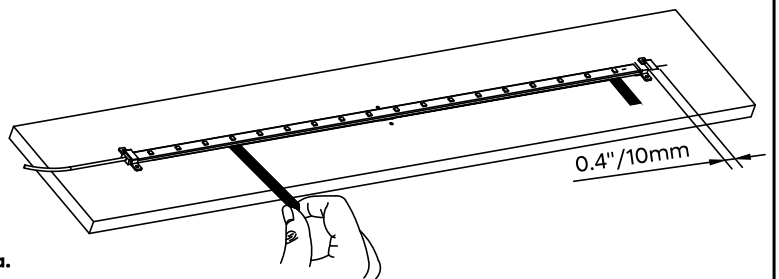

- 4**
- Lock the remaining fixings.
 - Verrouillez les autres fixations.
 - Die restlichen Befestigungen anziehen.
 - Bloccare i restanti elementi di fissaggio.
 - Bloquee las fijaciones restantes.
 - 나머지 고정 부품을 잠급니다.
 - 残りの固定具を留めます。
 - 锁上剩下的固定件。

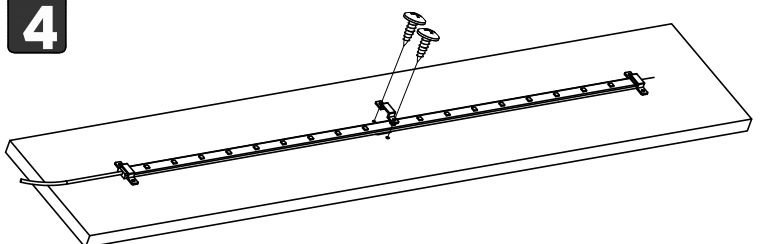

1

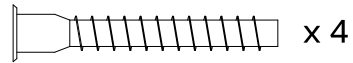
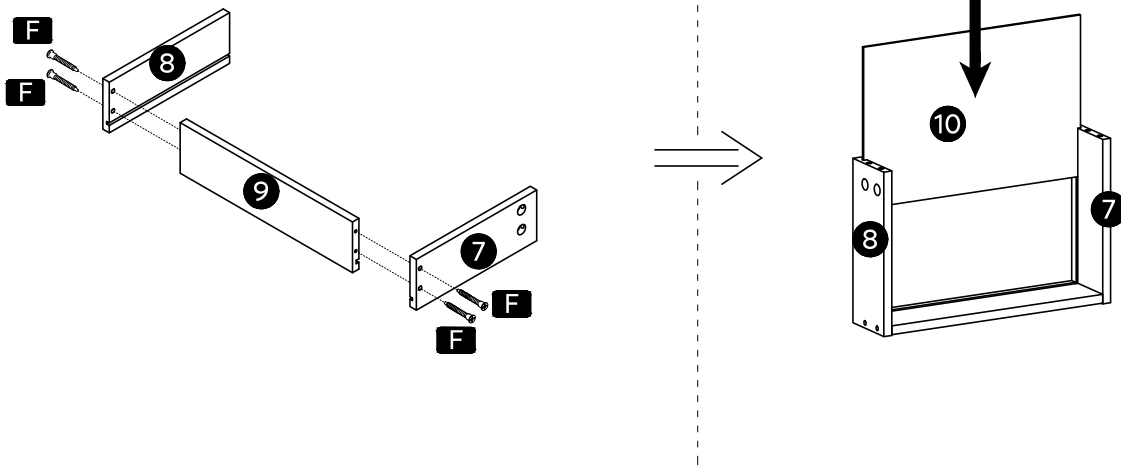

x 4

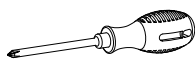

F ST5x35mm

x2

B200980N

2

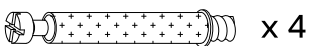
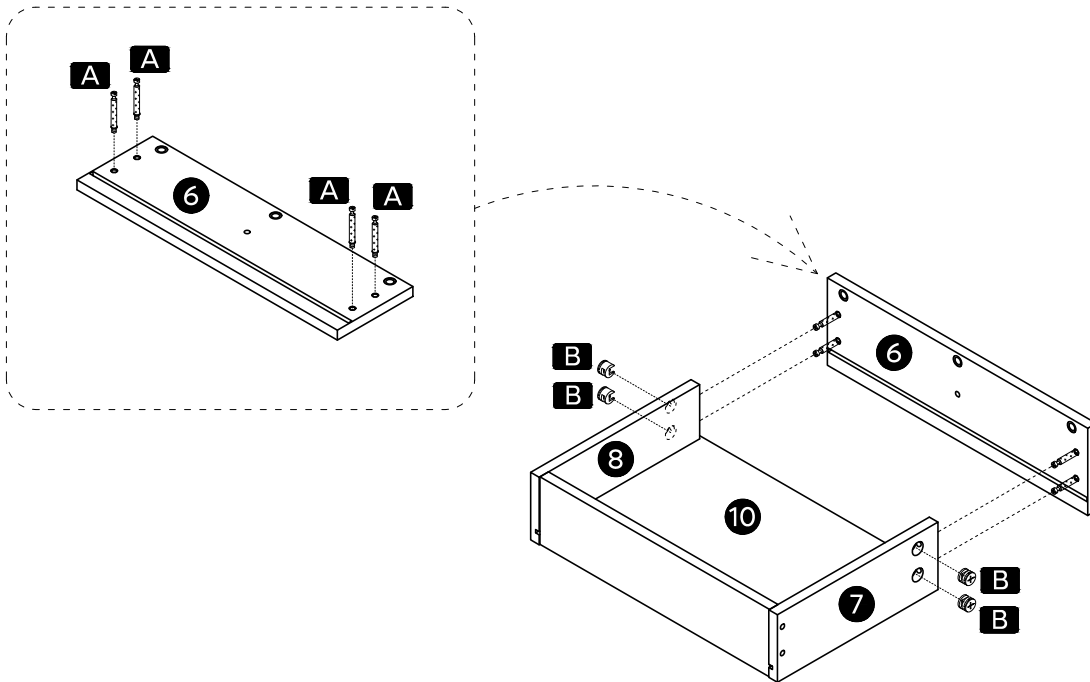

x 4



x 4

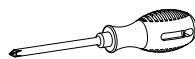



A ST6x35mm

B Ø15mm

x2

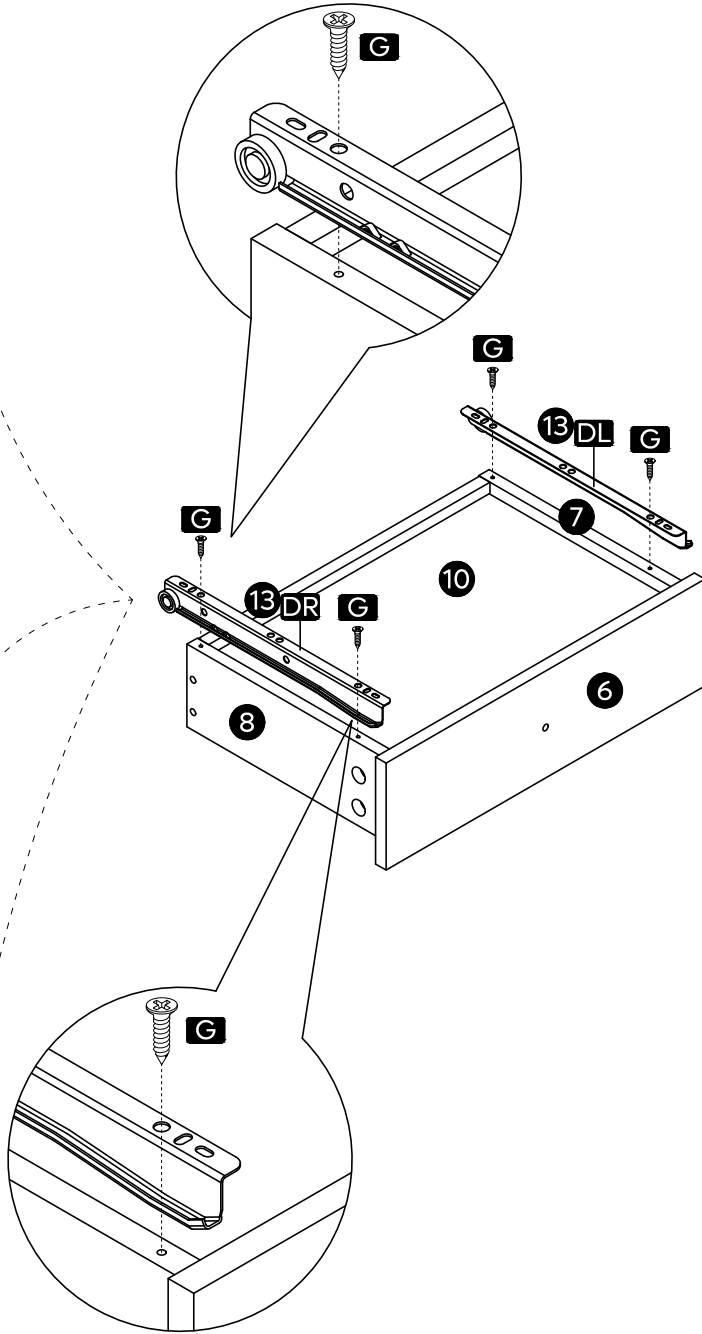
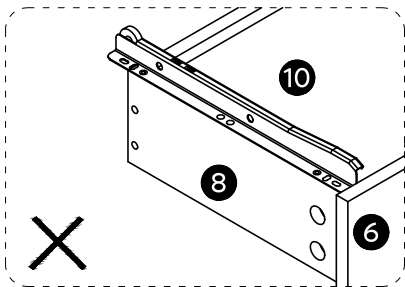
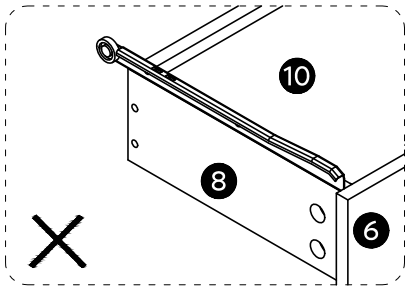
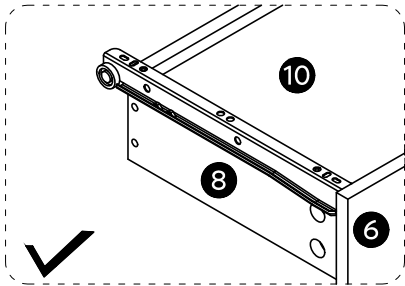
B200980N



⊕  x 4
G ST3x14mm

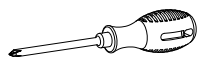

x2
B200980N

4

※The rough surface of #11 faces outward.
 ※La surface rugueuse de #11 est orientée vers l'extérieur.
 ※Die raue Oberfläche von #11 zeigt nach außen.
 ※La superficie ruvida della #11 è rivolta verso l'esterno.
 ※La superficie áspera del número 11 está hacia afuera.
 ※#11의 거친 표면은 바깥쪽을 향한다.
 ※#11の粗面は外側。
 ※#11的粗糙面朝外。

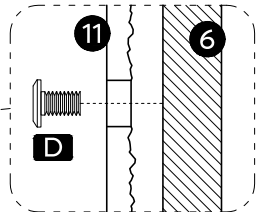
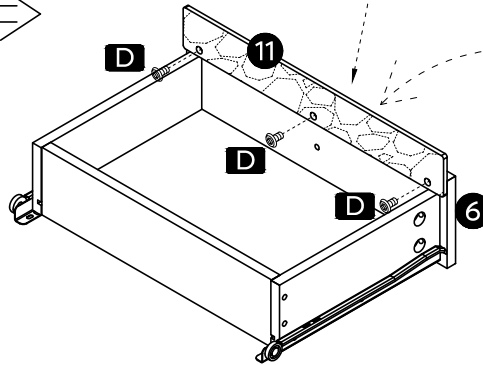
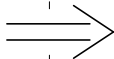
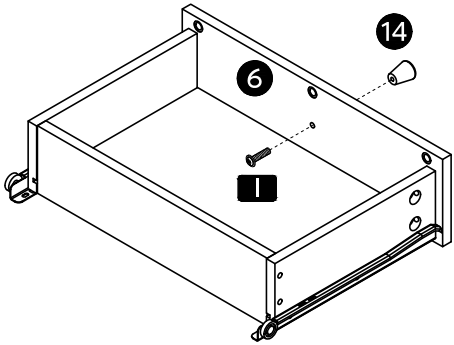

x2
B200980N

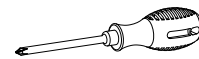
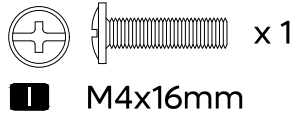
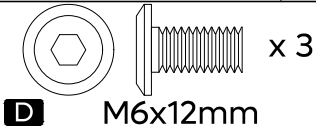

5

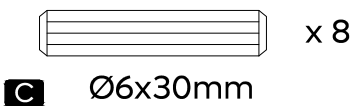
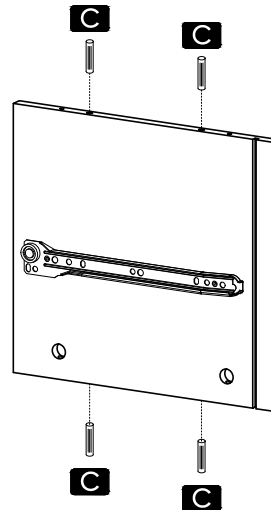
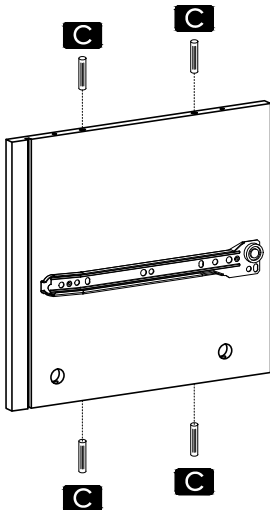

x2
B200980N

6

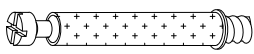
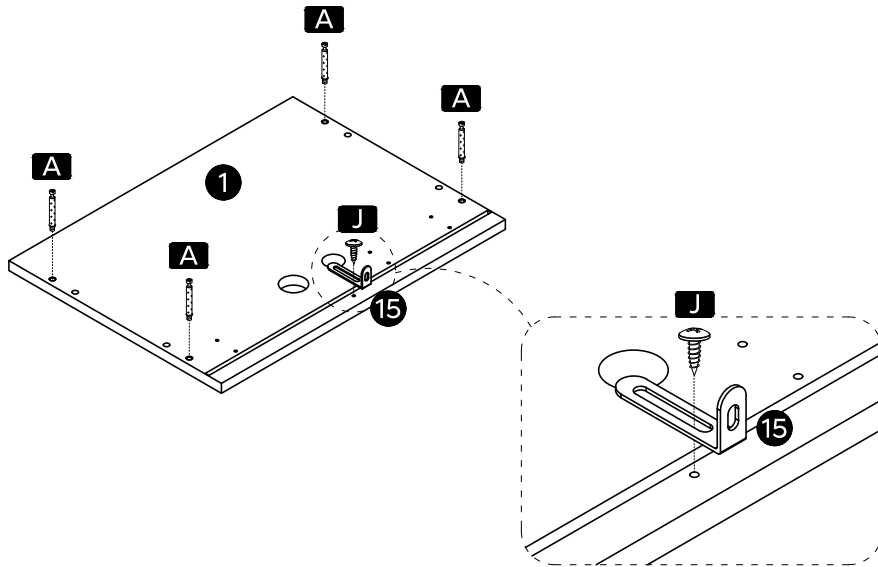

x 4

A ST6x35mm

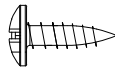

x 1

J ST3.5x10mm

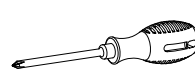

x2
B200980N

7

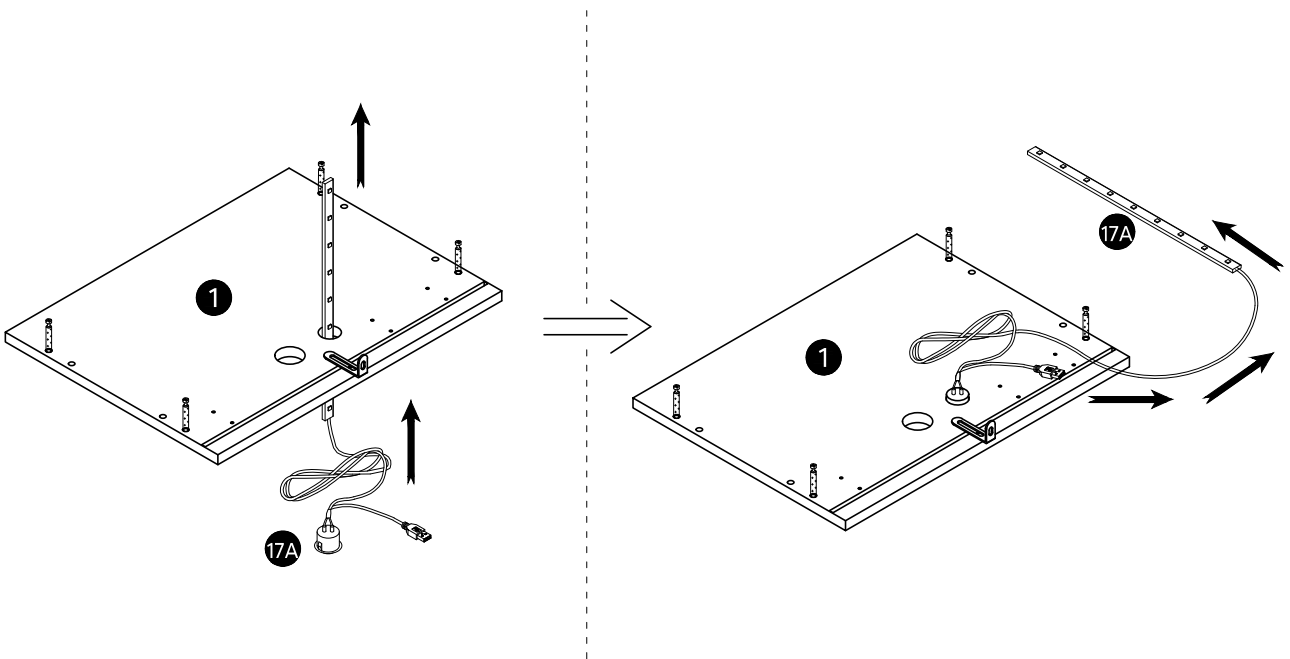

x2
B200980N

A

Style A: Step 8-13,20-23

Style A: Étape 8-13,20-23

Ausführung A: Schritt 8-13,20-23

Stile A: Step 8-13,20-23

Estilo A: paso 8-13,20-23

스타일 A: 8-13,20-23 단계

スタイル A: ステップ 8-13,20-23

安装方式 A: 8-13,20-23

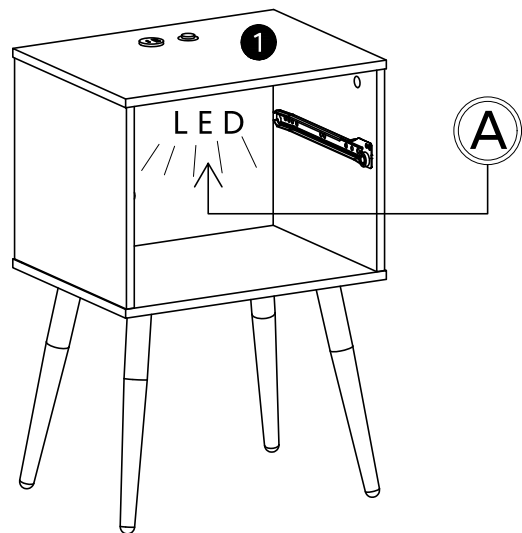

B

Style B: Step 14-23

Style B: Étape 14-23

Ausführung B: Schritt 14-23

Stile B: Step 14-23

Estilo B: paso 14-23

스타일 B: 14-23 단계

スタイル B: ステップ 14-23

安装方式 B: 14-23

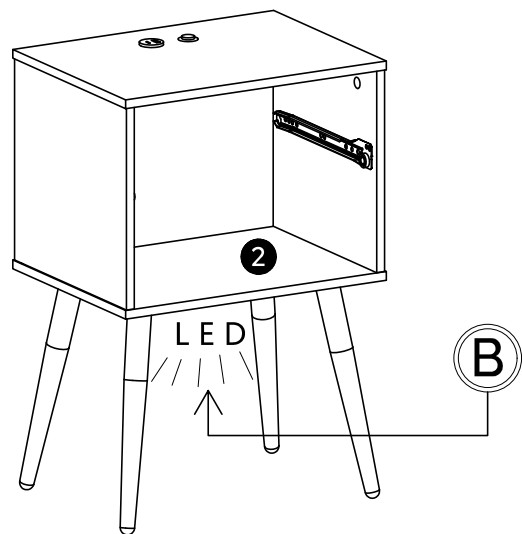

8

A

- Please refer to "Detailed Installation for LED Strip" on page "9".
- Veuillez consulter "Installation détaillée de la bande LED" sur la page "9".
- Siehe Seite "9" der "Ausführlichen Anbringungsanleitung für LED-Streifen".
- Fare riferimento a "Installazione dettagliata della striscia LED" a pagina "9".
- Consulte "Instalación detallada de la tira de LED" en la página "9".
- "9페이지의" "LED 램프 상세 설치"를 참조하십시오.
- "9" 페이지にある"LED 스트리플라이트の設置に関する詳細説明"を参照してください。
- 请参考第 "9" 页 "LED 灯带安装方法"

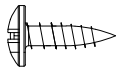
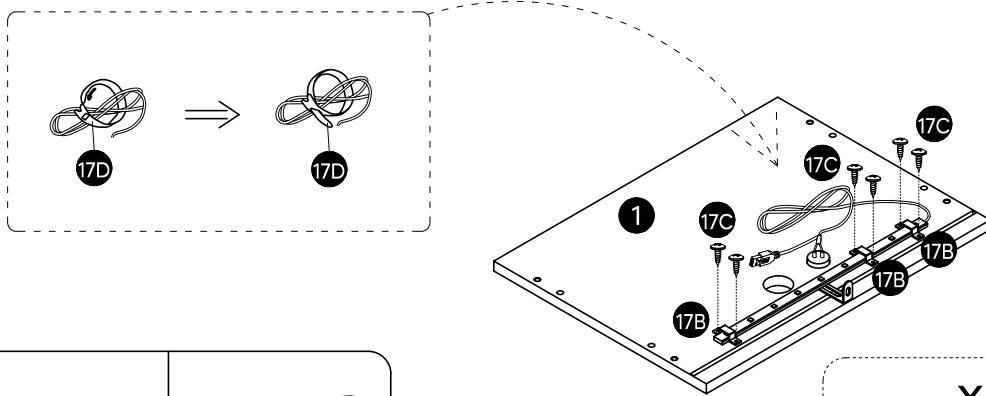

x 6

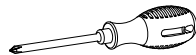

17C

x2

B200980N

9

A

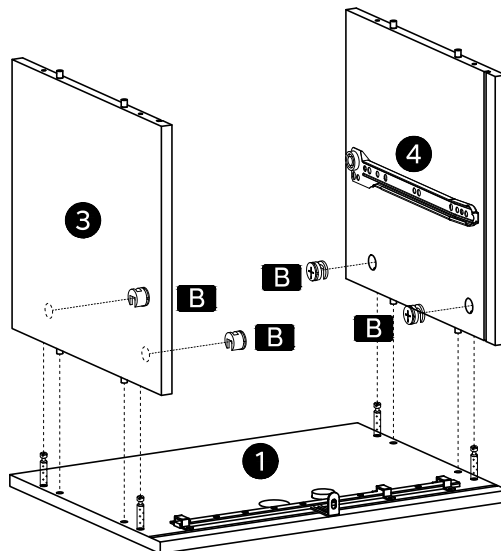

x 4

B Ø15mm

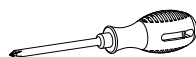

x2

B200980N

B200940M/B200980N

10

A

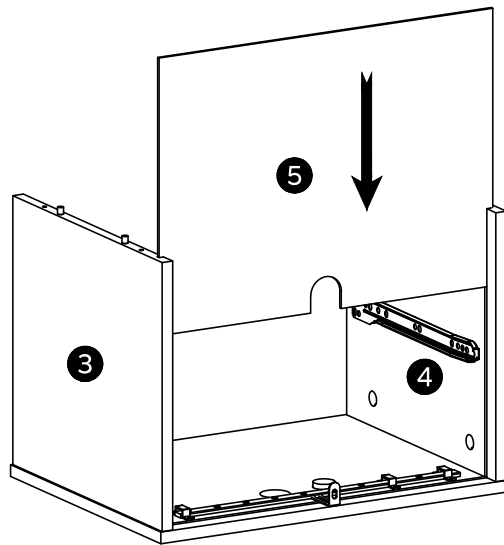

x2
B200980N

11

A

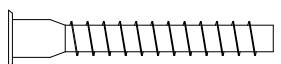
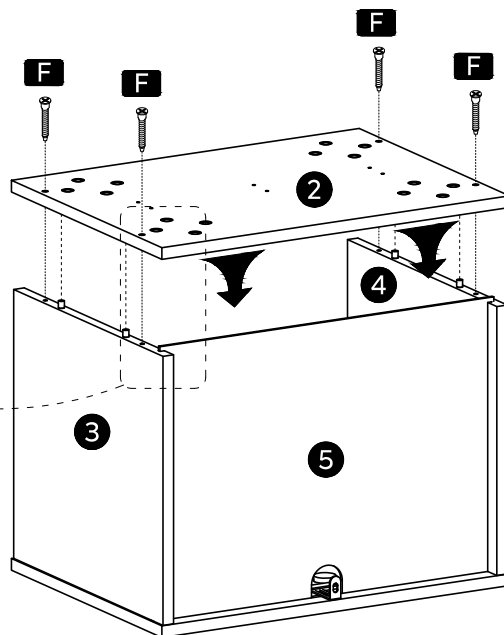
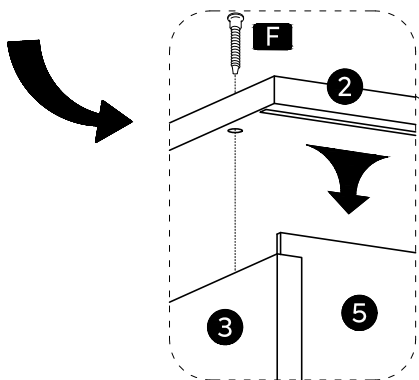
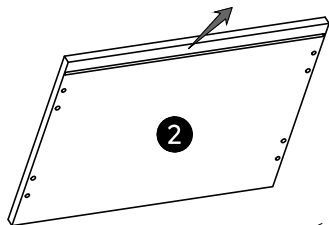

x 4

ST5x35mm

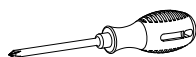

x2
B200980N

12

(A)

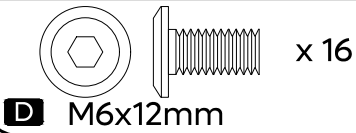
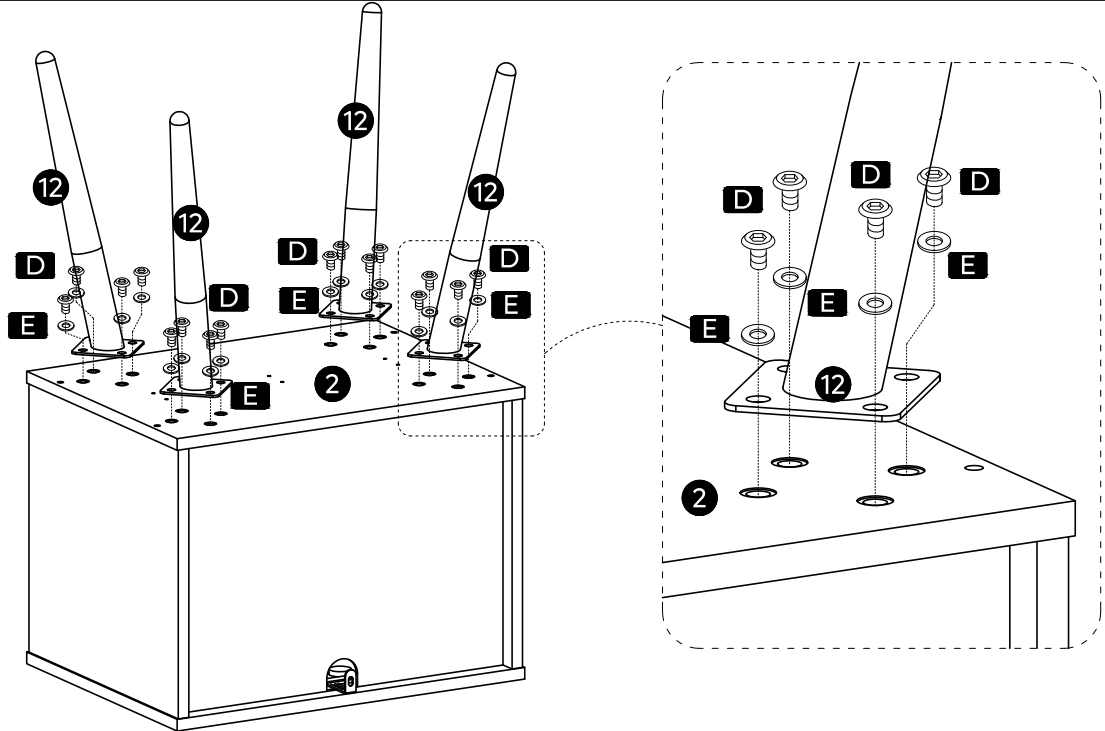

x2
B200980N

13

(A)

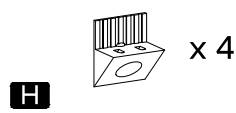
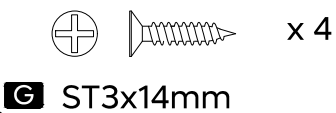
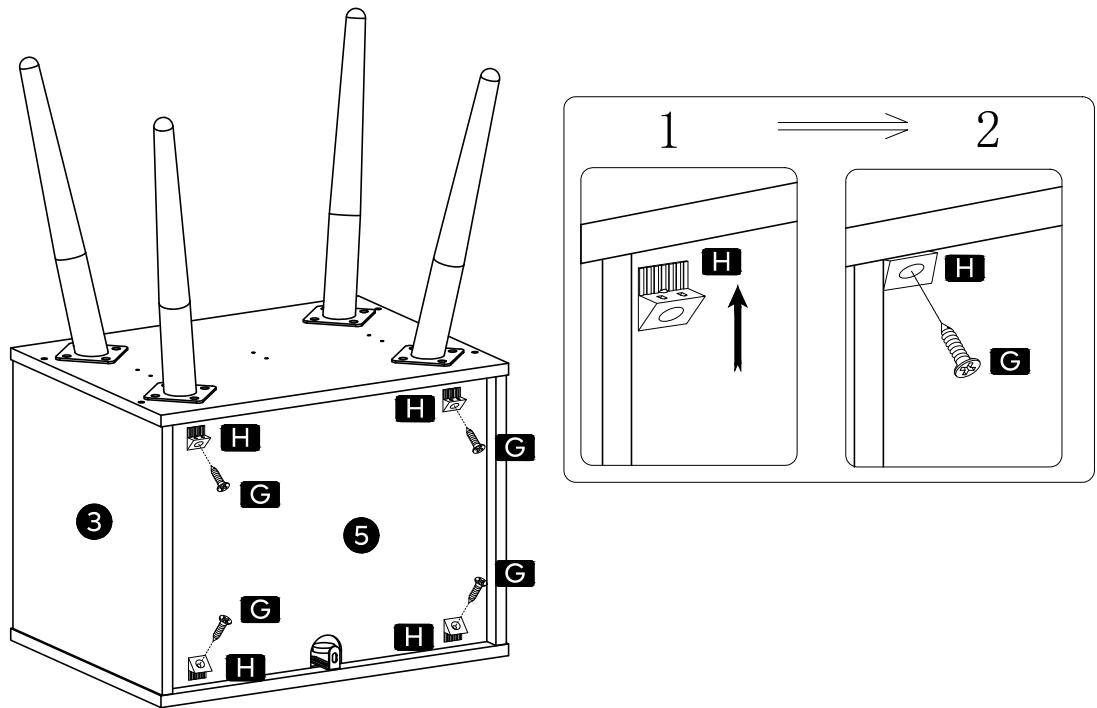

x2
B200980N

B200940M/B200980N

14

(B)

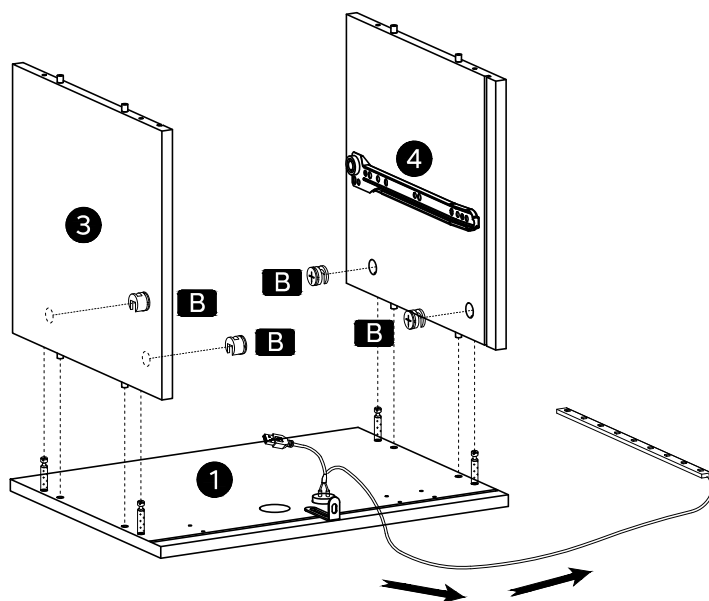

x 4

B Ø15mm

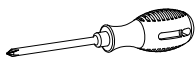

x2

B200980N

15

(B)

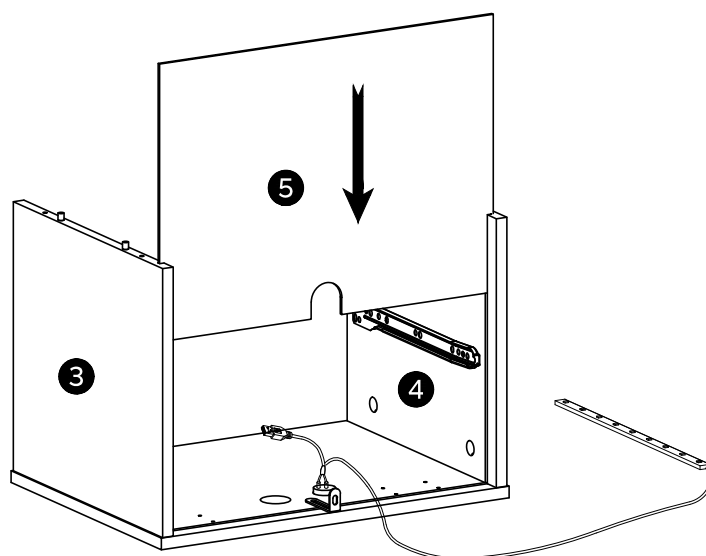

x2

B200980N

16

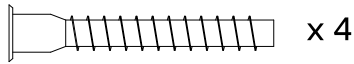
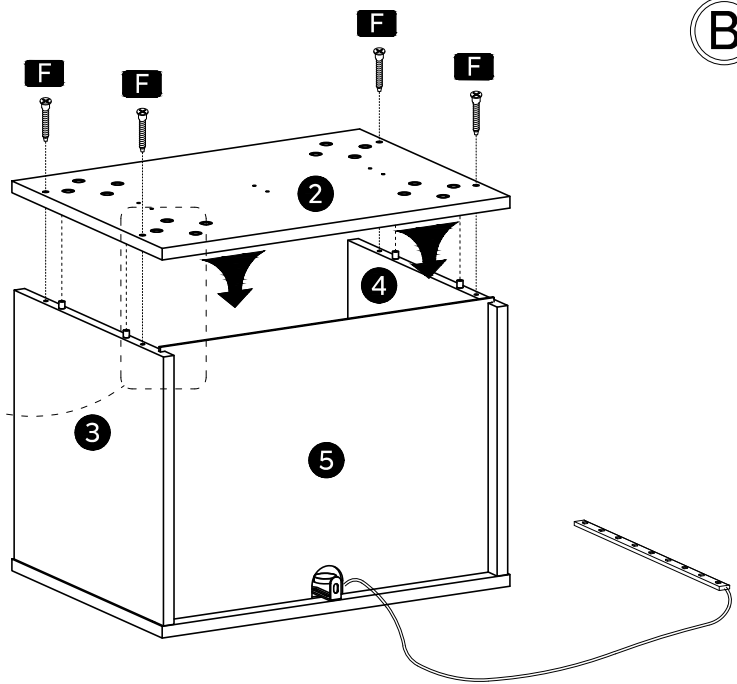
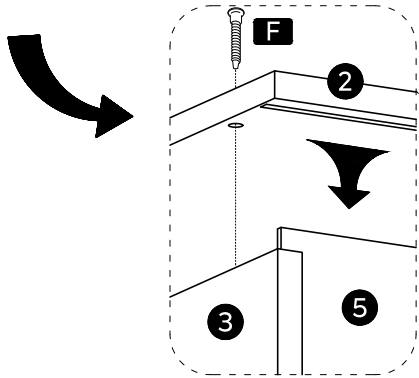
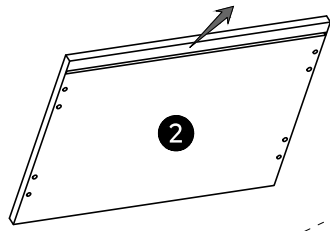

F

ST5x35mm

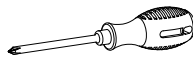

x2

B200980N

17

(B)

- Please refer to "Detailed Installation for LED Strip" on page "9".
- Veuillez consulter "Installation détaillée de la bande LED" sur la page "9".
- Siehe Seite "9" der "Ausführlichen Anbringungsanleitung für LED-Streifen".
- Fare riferimento a "Installazione dettagliata della striscia LED" a pagina "9".
- Consulte "Instalación detallada de la tira de LED" en la página "9".
- "9페이지의" "LED 램프 상세 설치" 를 참조하십시오.
- "9" 페이지にある"LED 스트립 라이트의設置に関する詳細説明"を参照してください。
- 请参考第 "9" 页 "LED 灯带安装方法"

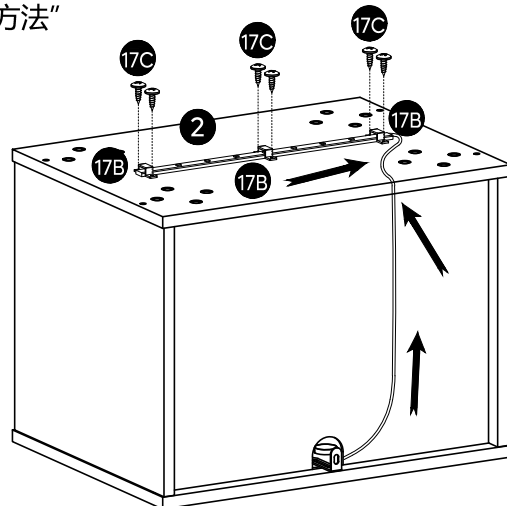

x2
B200980N

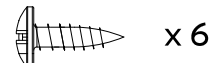

17C

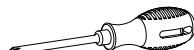

B200940M/B200980N

18

(B)

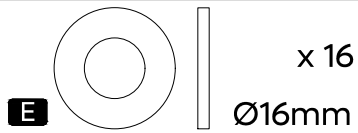
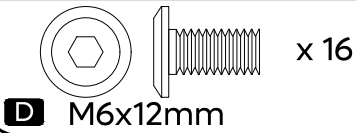
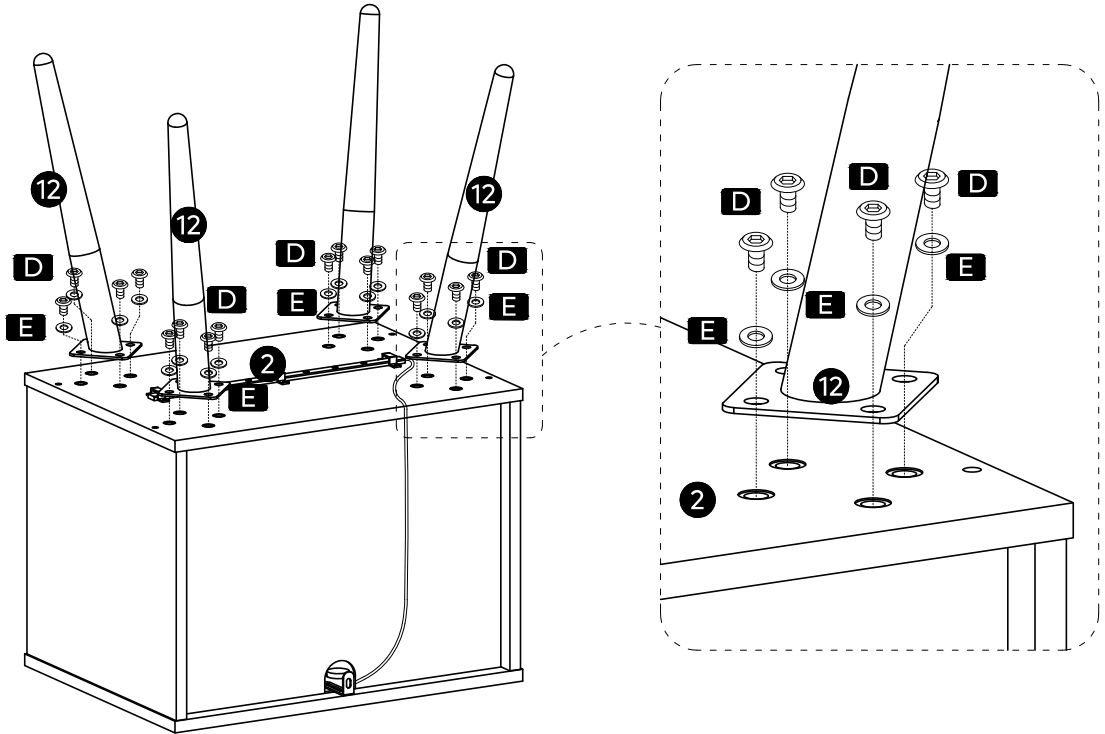

x2
B200980N

19

(B)

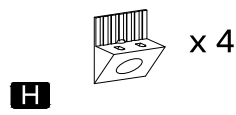
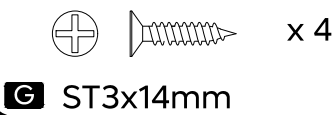
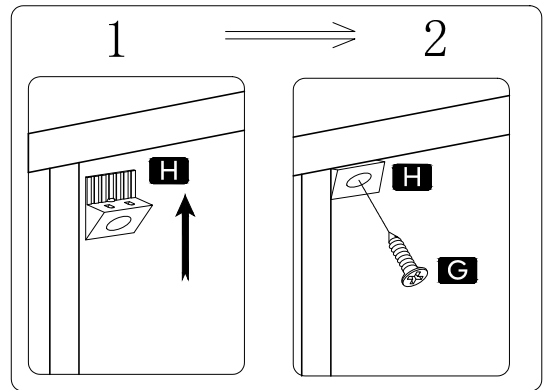
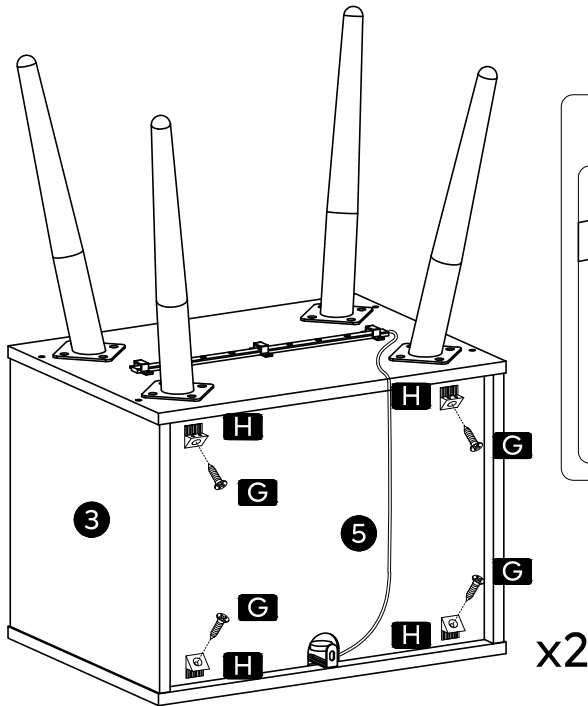

x2
B200980N

20

(A) / (B)

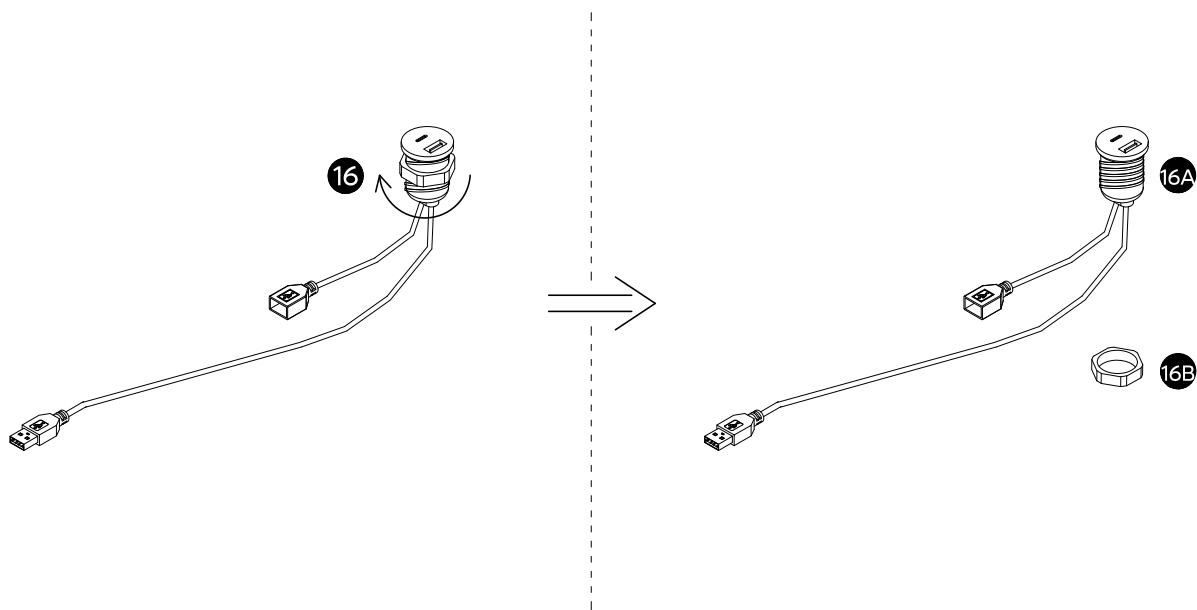

x2
B200980N

21

(A) / (B)

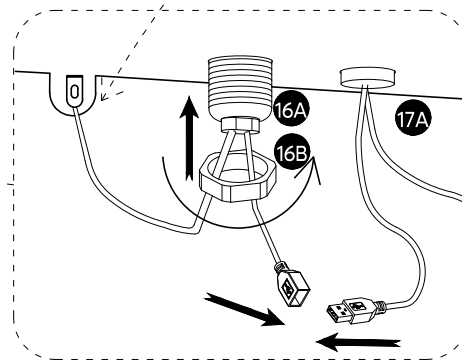
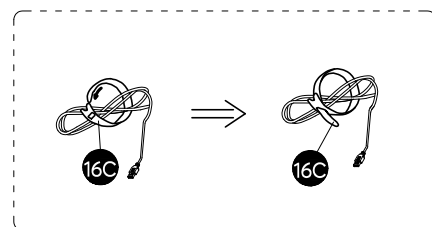
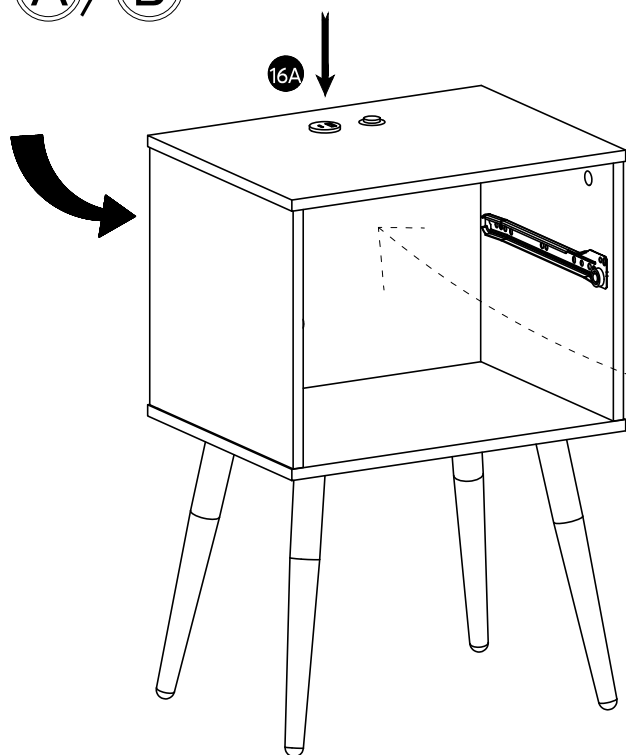

x2
B200980N

(A)/(B)

WALL

WALL
Mur
WAND
PARETE
MURO
壁
墙体

WALL

1

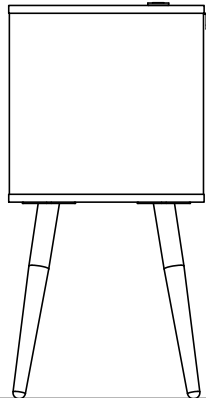

2

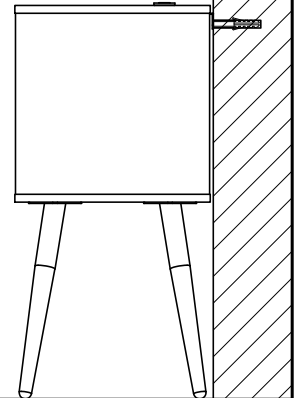

WALL

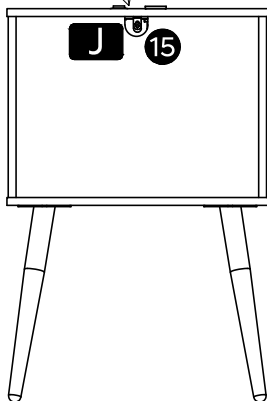

WALL

3

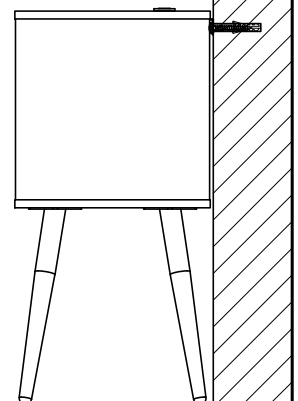

4

K

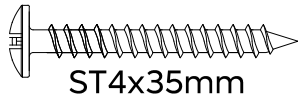

ST4x35mm

x 1

L



Ø8mm

x 1

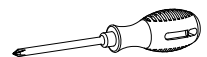

※ Please fasten this item to wall for protection and safety.

1. Drill 1 holes in the wall and insert L into holes.

※ You may need to use rubber mallet for tapping L.

2. Use K to attach L with "15".

x2

B200980N

←

※ **Veillez fixer ce buffet de salle à manger sur votre mur pour plus de protection et de sécurité.**

1. Percez 1 trou dans le mur et insérez L dans les trous.
- ※ Vous devrez peut-être utiliser un maillet en caoutchouc pour frapper L.
2. Utilisez K pour connecter L avec "15".

※ **Bitte befestigen Sie diesen Artikel zum Schutz und zur Sicherheit an der Wand.**

1. Bohren Sie 1 Löcher in die Wand und setzen Sie die L in die Löcher ein.
- ※ Möglicherweise müssen Sie einen Gummihammer zum Llopfen von L verwenden.
2. Verwenden Sie K, um L mit "15" zu verbinden.

※ **Si prega di fissare questo articolo alla parete per protezione e sicurezza.**

1. Praticare 1 fori nella parete e inserire L nei fori.
- ※ Potrebbe essere necessario usare un martello di gomma per fissare il pezzo L.
2. Utilizzare K per collegare L con "15".

※ **Fije este elemento a la pared como medida de protección y seguridad.**

1. Taladre 1 orificios en la pared e inserte el tornillo L en los orificios.
- ※ Es posible que tenga que utilizar el mazo de goma para golpear L.
2. Utilice K para unir L con "15".

※ 보호와 안전을 위해 이 물건을 벽에 고정하십시오 .

1. 벽에 구멍 1 개를 뚫고 L 를 구멍에 삽입합니다 .
- ※ 고무망치로 L 를 두드려야 할 수도 있습니다 .
2. K 를 사용하여 L 를 "15"에 연결합니다 .

※ **安全のために、オープンシェルフを壁に固定してください。**

1. 壁に 1 つ穴を開け、L を穴に差し込む。
- ※ L を叩くにはラバーハンマーが必要かもしれません。
2. K を使用し、L と"15"を接続してください。

※ **请将此产品固定在墙上以防护和安全。**

1. 在墙上钻 1 个孔，然后将 L 插入孔中。
- ※ 您可能需要使用橡皮槌敲击 L 。
2. 用 K 将 L 与 配件"15" 连接。

x2
B200980N

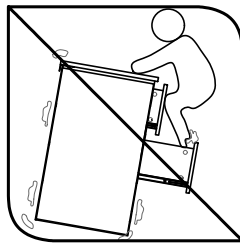
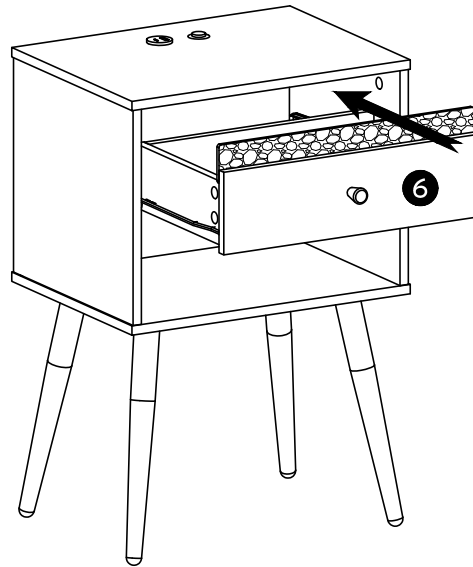

STOP!

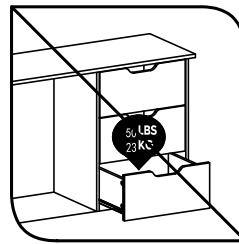

OVERLOAD!

WARNING

- * Never allow children to climb or hang on drawers, handles, towel rack, paper towel holder.
- * Do not overload.

"AVERTISSEMENT"

- * Ne pas laisser les enfants grimper ou s'accrocher aux tiroirs, poignées, porte-serviettes, porte-essuie-tout.
- * Ne pas surcharger.

ACHTUNG

- * Erlauben Sie Kindern nicht, auf Schubladen, Griffe, Handtuchhalter und Papiertuchhalter zu klettern oder sich daran zu hängen.
- * Nicht überlasten

AVVERTENZA

- * Non consentire mai ai bambini di arrampicarsi o aggrapparsi a cassetti, maniglie, portasciugamani, porta asciugamani di carta.
- * Non sovraccaricare.

ADVERTENCIA

- * Nunca permita que los niños se suban o se cuelguen de los cajones, las manijas, el toallero o el soporte para toallas de papel.
- * No sobrecargue.

警告

- *引き出し、取っ手、タオル掛け、ペーパータオルホルダーにお子様に登ったり、ぶら下がったりしないように十分注意してください。
- *無理な荷重を加えないようにしてください。

경고

- * 어린이가 서랍, 손잡이, 수건걸이, 휴지걸이에 기어오르거나 걸지 않도록 하십시오.
- * 과부하하지 마십시오.

警告

- *切勿让儿童攀爬或悬挂在抽屉、把手、毛巾架、纸巾架上。
- *不要超载。



MADE IN CHINA

Love coming home.

Comfort Zone Co., Limited

RM1903 19F BeiYou technology Building, Yuehai Street,
No.42 Gaoxin South Ring Road, Nanshan, Shenzhen

CUSTOMER SUPPORT	
North American	Global
888-666-1086 Service.US@pinmoco.com	Service.US@pinmoco.com