

# ASSEMBLY INSTRUCTIONS

---

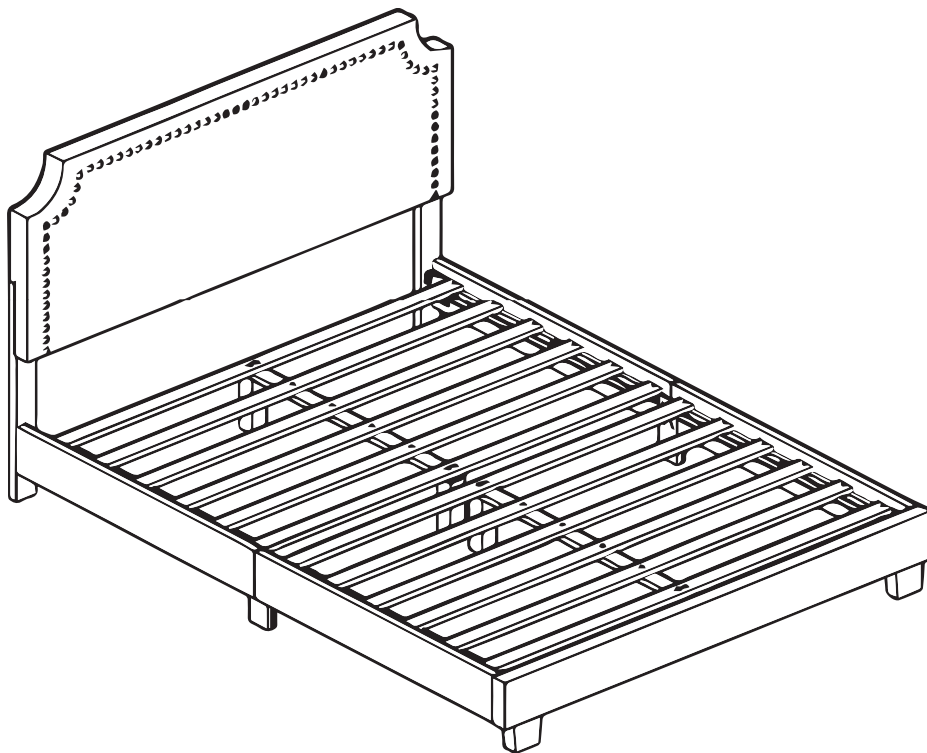

## TOOLS REQUIRED

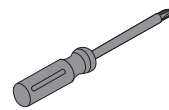

Screwdriver  
(Not included)



2 - People

## ASSEMBLY RATING



EASY → DIFFICULT

The Assembly Rating is a 5-point system showing the level of effort needed to assemble a specific product.

# PRE ASSEMBLY INTRODUCTION

We understand building ready-to-assemble furniture can be a challenging experience for some. To help avoid confusion, we have provided some helpful tips that may speed up the process.

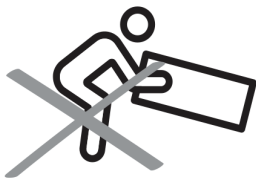

## Teamwork

ALWAYS have at least two people to help with transporting and assembling the product to avoid potential injury and/or damage.

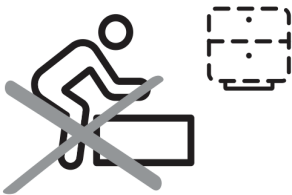

## Suitable Location

Assembling near the area of the intended location is highly recommended.



## Sufficient Space

Make sure you have enough space to move around during the assembly.



## Avoid Scratches

Use cardboard, blankets or a carpeted area while assembling furniture to prevent to prevent scratches and damages.



## Flat Surface

Make sure the furniture rests on a flat and level surface with each leg evenly touching the floor.

# ASSEMBLY AND CARE ADVICE



**FAILURE TO FOLLOW THE GUIDELINES BELOW MAY RESULT IN INJURY AND/OR PROPERTY DAMAGE.**



Position each part correctly and insert screws or bolts into their respective holes.

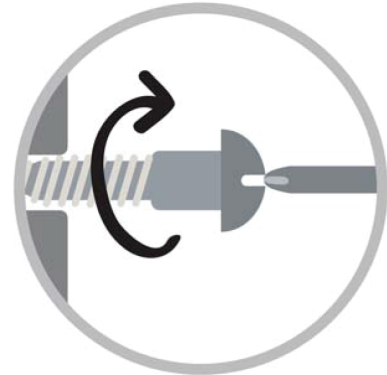

Turn clockwise to tighten and only tighten when step is completed or when instructed to do so.



Use the appropriate hand tools or power tools for assembly. Select steps, such as tightening screws and/or bolts, may require hand tools to avoid causing damage during assembly.



Save the instructions and store any supplied tools for later maintenance.



After two weeks, check and tighten any loose hardware and repeat again every six months thereafter.

**IT IS THE USER'S RESPONSIBILITY TO MAINTAIN THE FURNITURE. THE HARDWARE MAY LOOSEN OVER TIME AND MAY CAUSE THE FURNITURE TO BE WOBBLY AND UNABLE TO SUPPORT ITS INTENDED WEIGHT CAPACITY. THIS MAY LEAD TO COLLAPSE AND MAY CAUSE SERIOUS INJURY.**

# BED

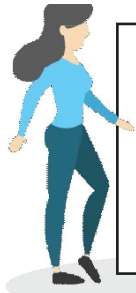

- Please keep instructions for future reference.
- Check the quantity and irregularity of parts and hardware before you start.

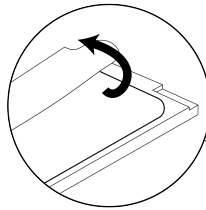

**Tip!**  
Parts are stored in the back of the headboard.

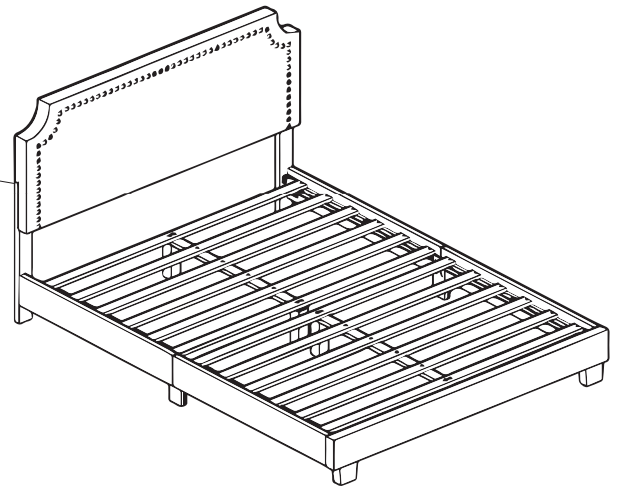

## PARTS

1

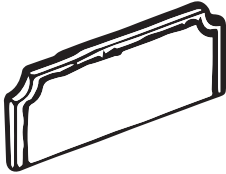

HEADBOARD  
1 pc.

2L



HEADBOARD  
LEG (Left)  
1 pc.

2R

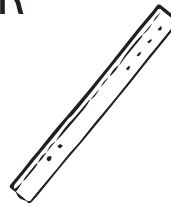

HEADBOARD  
LEG (Right)  
1 pc.

3L



SIDE RAIL (Left)  
2 pcs.

3R



SIDE RAIL (Right)  
2 pcs.

4

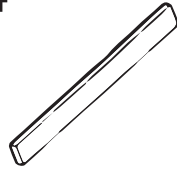

FOOTBOARD  
1 pc.

5



CENTER LEG  
4 pcs.

6

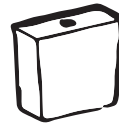

BED LEG  
2 pcs.

7



SR LEG  
2 pcs.

8



CENTER RAIL  
2 pcs.

9

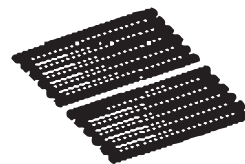

SLAT  
12 pcs. (2sets)

## HARDWARE

Ⓐ



ALLEN KEY M4  
Long Ball Head  
1 pc.

Ⓑ

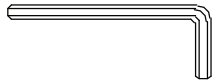

ALLEN KEY  
M5  
1 pc.

Ⓒ

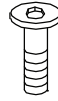

JCBC BOLT  
M6 x 25mm  
8 pcs.

Ⓓ

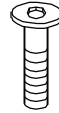

JCBC BOLT  
M6 x 40mm  
6 pcs.

Ⓔ

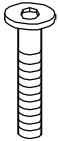

JCBC BOLT  
M6 x 50mm  
10 pcs.

Ⓕ



WOOD SCREW  
M4 x 25mm  
32 pcs.

Ⓖ

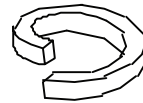

M6 SPRING  
WASHER  
6 pcs.

Ⓖ

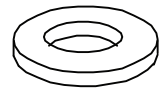

M6 FLAT  
WASHER  
6 pcs.

# ASSEMBLY INSTRUCTIONS

**1**

- Part #3L x 2pcs
- Part #3R x 2pcs
- Part #7 x 2pcs
- Hardware #C x 8pcs
- Hardware #A x 1pc

Attach the side rail leg (#7) to side rail (#3L/R) and secure by using Bolts (#C).

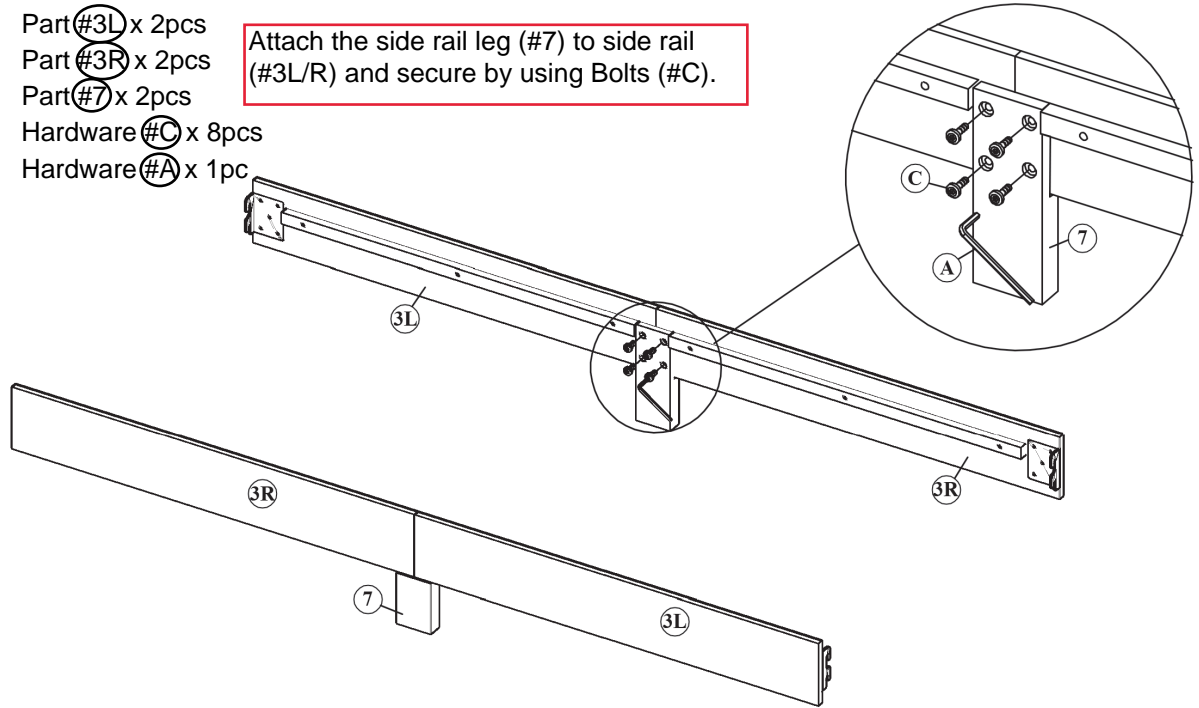

**2**

Lowest Position

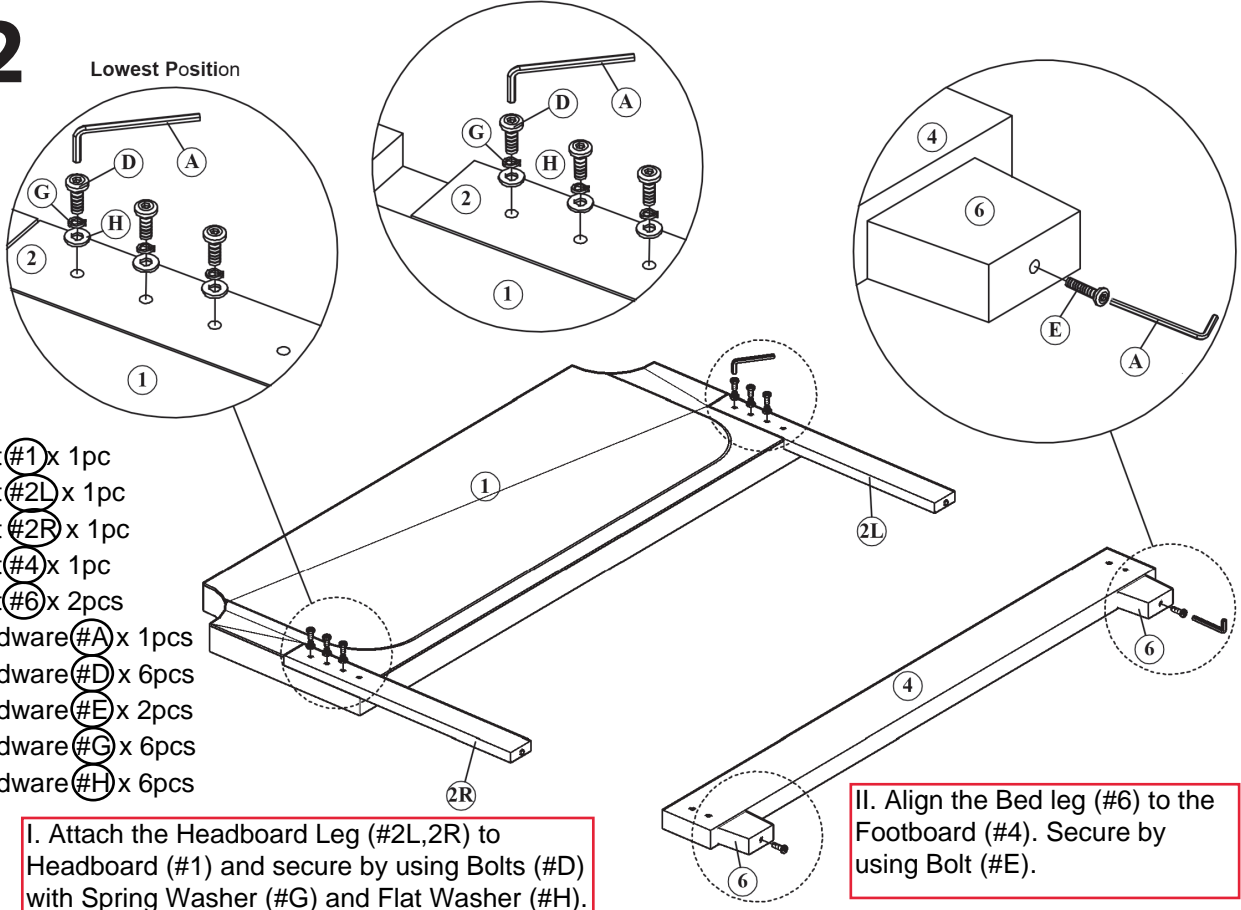

- Part #1 x 1pc
- Part #2L x 1pc
- Part #2R x 1pc
- Part #4 x 1pc
- Part #6 x 2pcs
- Hardware #A x 1pc
- Hardware #D x 6pcs
- Hardware #E x 2pcs
- Hardware #G x 6pcs
- Hardware #H x 6pcs

I. Attach the Headboard Leg (#2L,2R) to Headboard (#1) and secure by using Bolts (#D) with Spring Washer (#G) and Flat Washer (#H).

II. Align the Bed leg (#6) to the Footboard (#4). Secure by using Bolt (#E).

# ASSEMBLY INSTRUCTIONS

## 3

Align the side rail (#3L/R) in between the Headboard (#1) and Footboard (#4) and secure by using the bolts found on the Headboard (#1) and Footboard(#4).

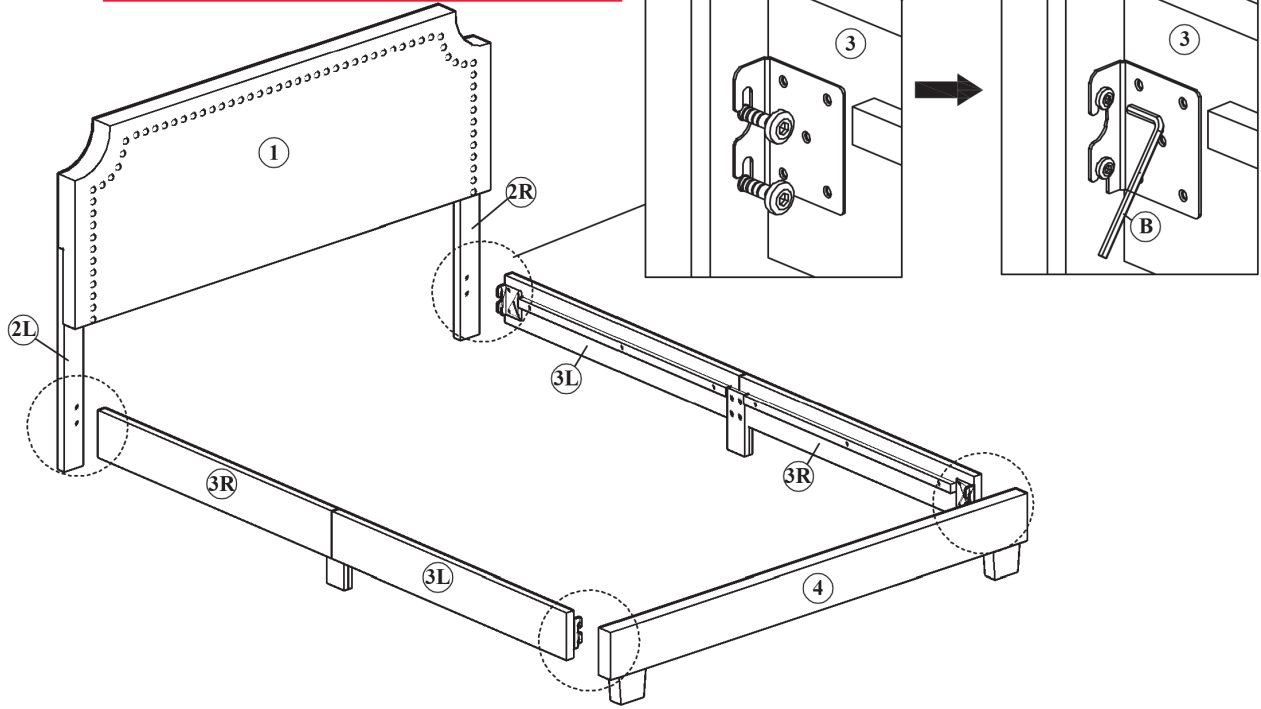

## 4

- Part #5 x 4pcs
- Part #8 x 2pcs
- Part #9 x 12 pcs
- Hardware #A x 1pc
- Hardware #E x 8pcs

Align the Bed Slat (#9), Center rail (#8), and the Center Leg (#5) and secure together by using Bolts (#E).

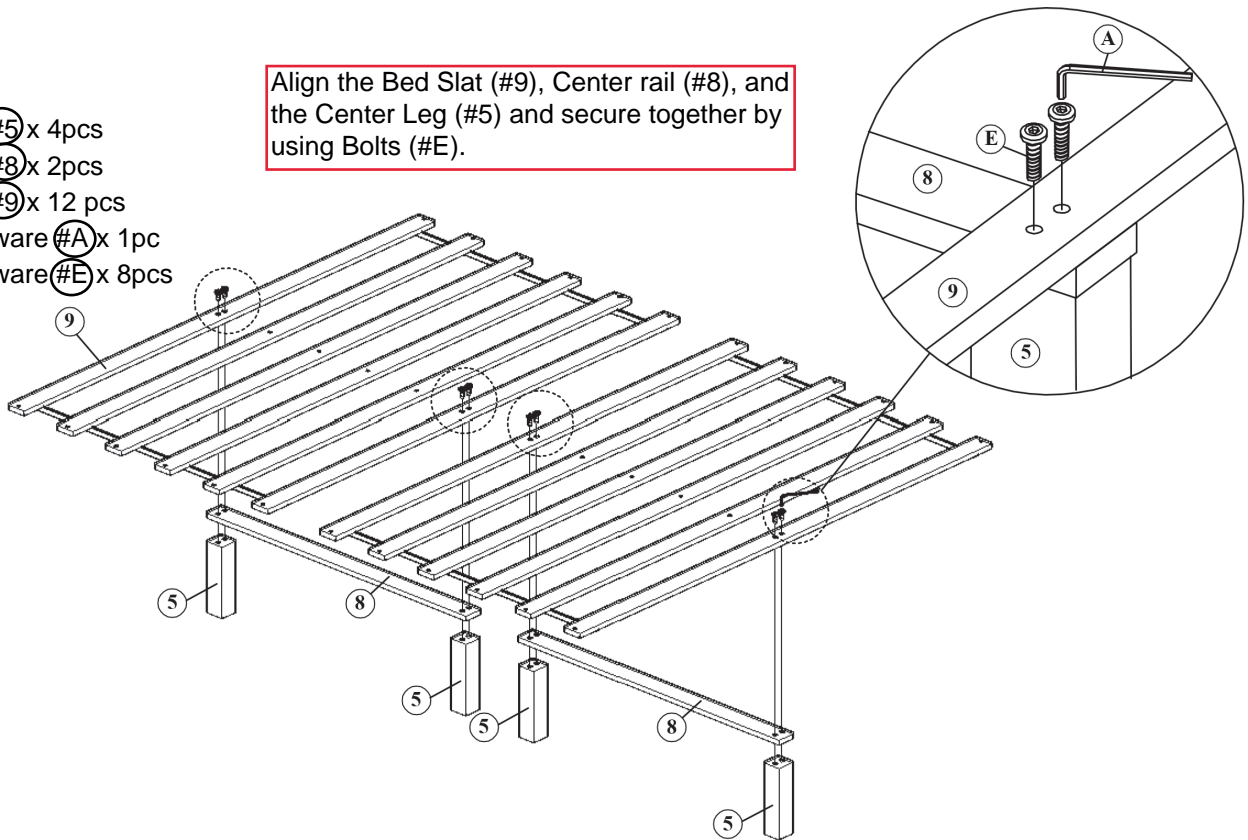

# ASSEMBLY INSTRUCTIONS

## 5

Hardware (#F) x 32pcs

Spread the Bed Slat (#9) in the frame and secure by using Screw (#F).

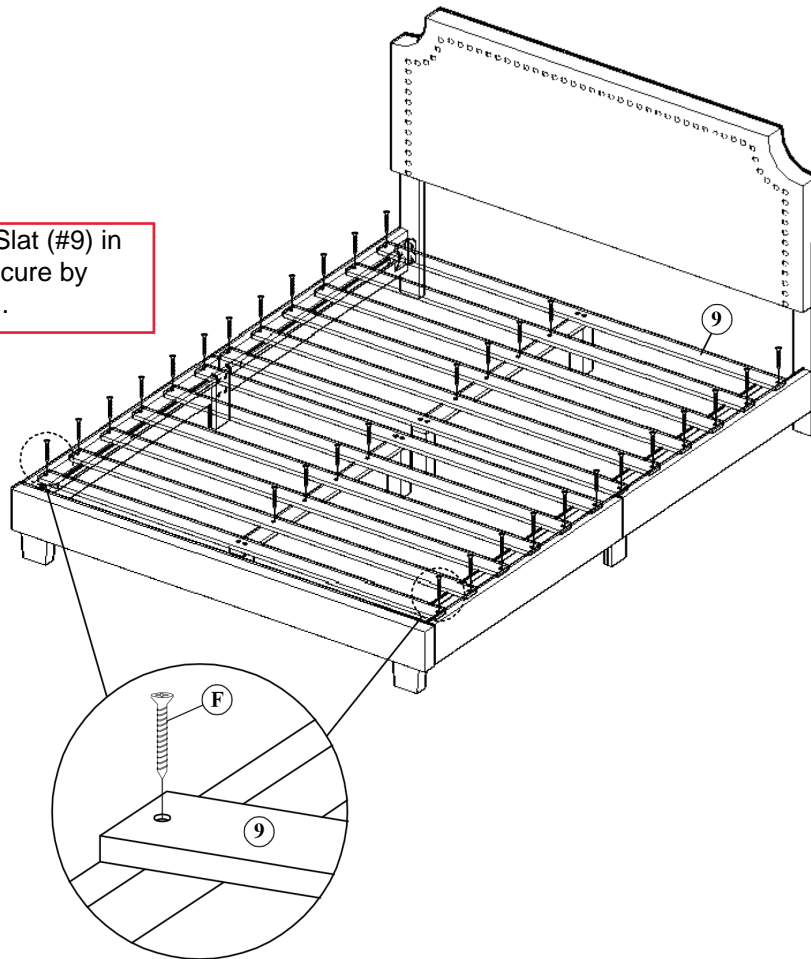

## 6

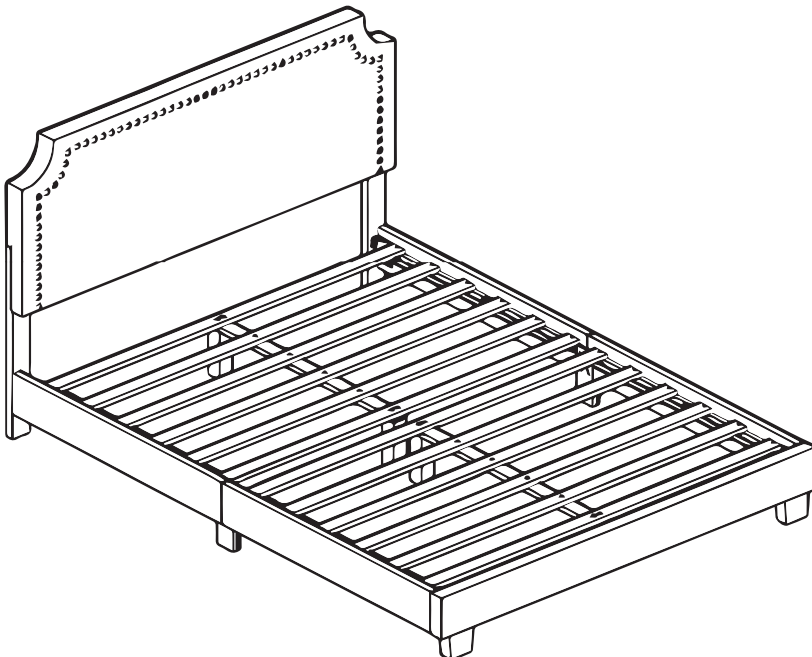

### ASSEMBLY COMPLETED



Please ensure the furniture rests on an even and flat surface. If the product wobbles or feels loose, double-check all bolts and/or screws are properly tightened and secured.



#### Keep this handy!

Please retain this instruction manual and any order-related information for future reference.



#### Lift, don't drag!

To avoid damage to product please always LIFT the product when transporting or adjusting the placement.