

# ASSEMBLY INSTRUCTIONS

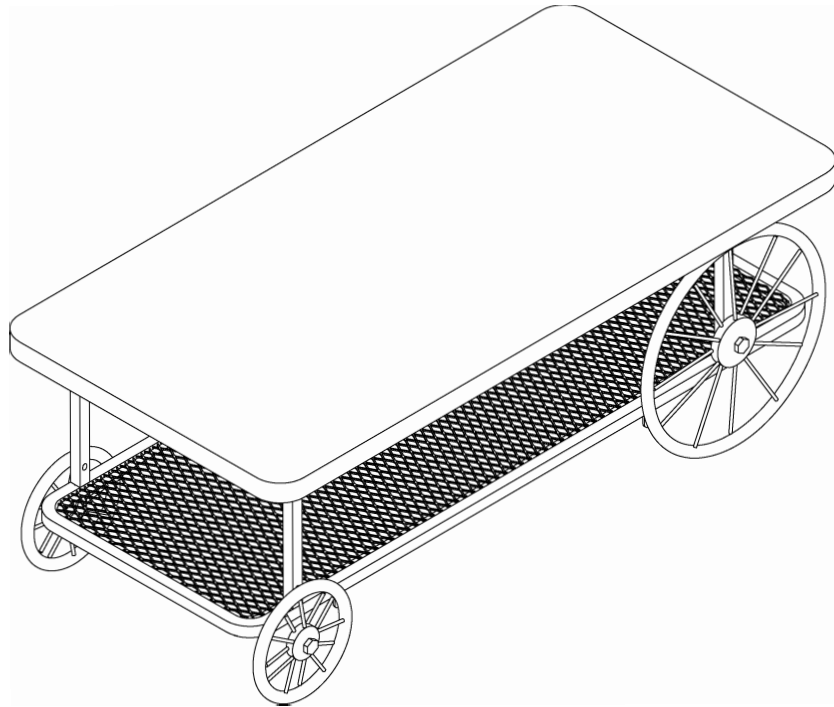

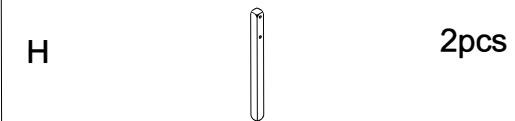
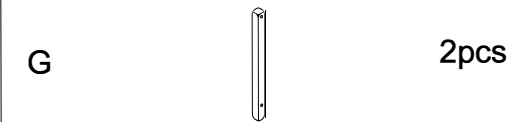
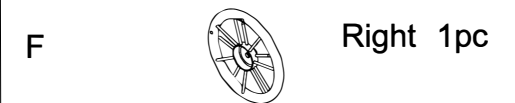
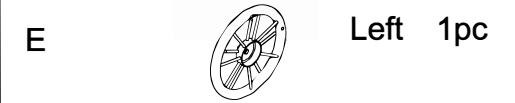
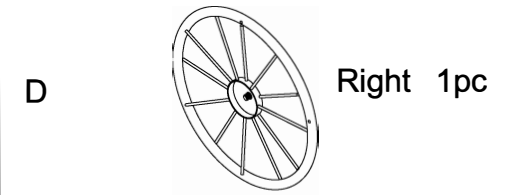
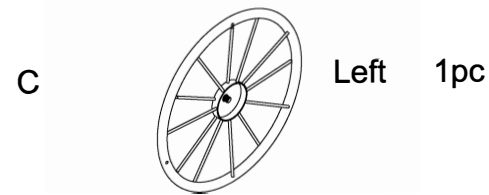
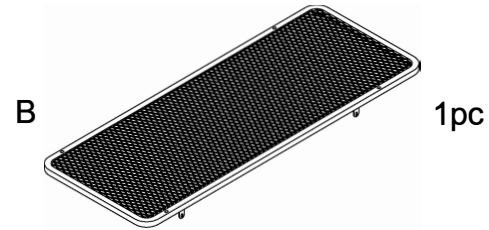
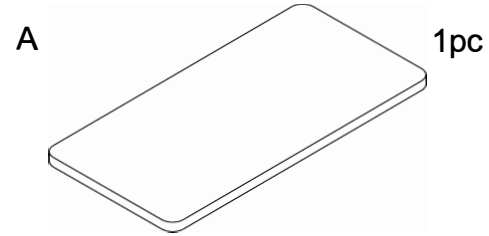

**Do not tighten screws until completely assembled.**

## PARTS IDENTIFICATION



## HARDWARE LIST

1		4pcs	2		12pcs	3		1pc
M6x15			M6x35			4x4		

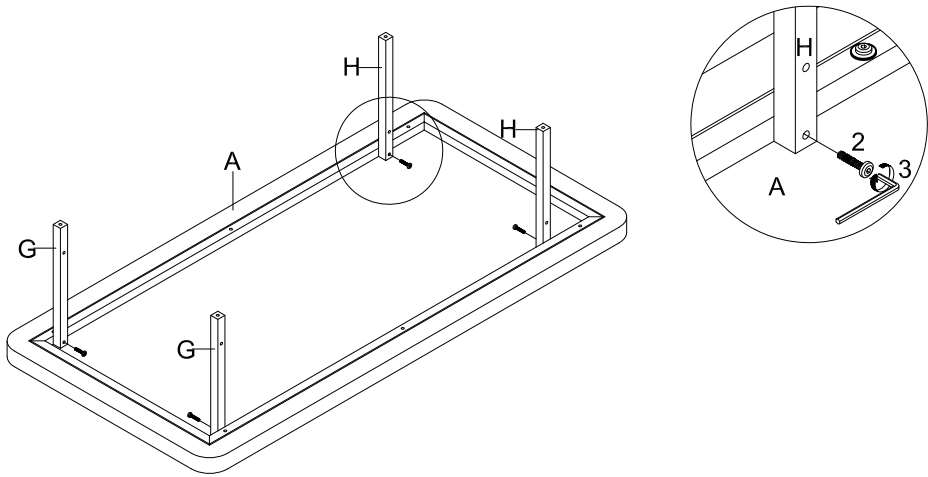

STEP 1.

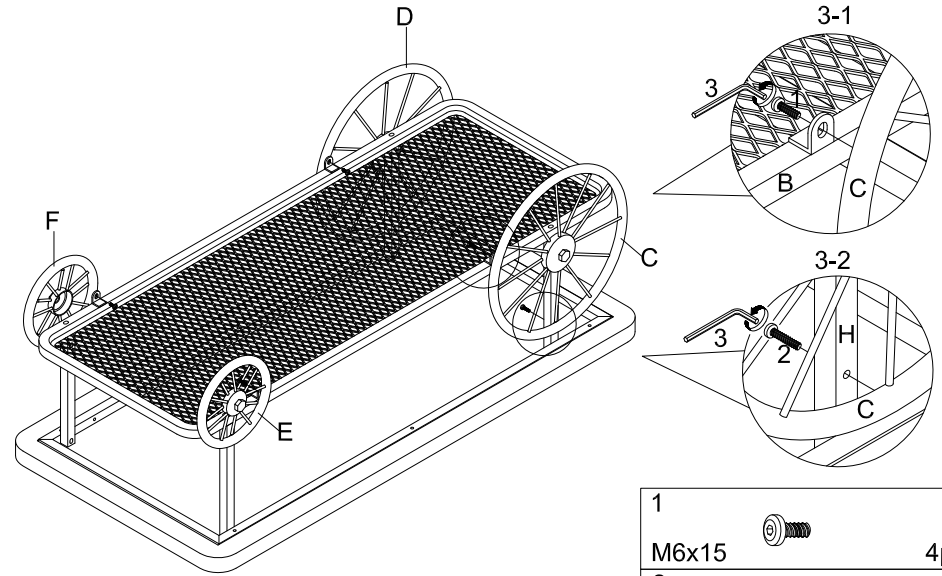

2  
M6x35 4pcs

STEP 3.



1		4pcs
M6x15		
2		4pcs
M6x35		

STEP 2.

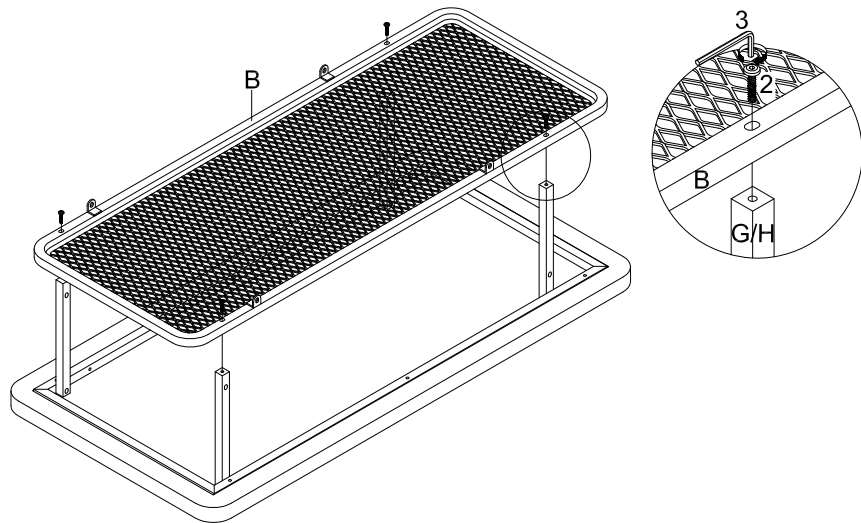

2  
M6x35 4pcs

STEP 4.

