



MCombo®

OWNER'S MANUAL

**HIGH LEG POWER
RECLINER CHAIR**

Hello,

Thank you for choosing MCombo®

Let's get started

○ PURCHASER'S AGREEMENT

By accepting delivery of this product, you promise that you will not change, alter, or modify this product or remove or render inoperable or unsafe any guards, shields or other safety features of this product.

You will not refuse or neglect any retrofit kits that MCombo may provide to enhance and preserve the safe use of this product.

CONTENTS

I	SAFETY GUIDELINES	- 01	VI	DISASSEMBLY INSTRUCTION	- 19
	<ul style="list-style-type: none"> • Mandatory • Danger • Warning • Symbols information • Disclaimer 			<ul style="list-style-type: none"> • Disconnect all Connections • Disassemble Armrests • Disassemble Backrest and Anti-forward-tipping • Disassemble Legs 	
II	ASSEMBLY INSTRUCTIONS	- 04	VII	WARRANTY	- 21
	<ul style="list-style-type: none"> • Product Parameters • Part List • Assembly Steps 				
III	OPERATING INSTRUCTIONS	- 13	VIII	RETURN / REPLACEMENT POLICY	- 22
	<ul style="list-style-type: none"> • Operation Precautions • Operation Instruction 				
IV	CARE AND MAINTENANCE	- 15			
	<ul style="list-style-type: none"> • Fabric Care • Faux Leather Care • Electronics Care • Disposal & Recycling 				
V	TROUBLESHOOTING	- 17			

I. SAFETY GUIDELINES

1. Mandatory

Read the safety and other instructions thoroughly before using your MCombo® product. Failure to follow the guidelines, warnings in this manual and those located on your product can result in personal injury or product damage and will void the product warranty. Keep this manual for future reference.

2. Danger

- To prevent suffocation, keep plastic bags away from children.
- Do not allow children play on or near the chair when in use. Serious injury or death could occur if a child is under the chair when the chair is in motion.
- Keep cord out of reach of small children, and do not use where it may be a trip hazard.
- Plug directly into a wall outlet. Do not use an extension cord or adapter.
- Do not use this product if it is wet, in water, around water or any liquid.
- Always leave in an upright and closed position. Keep hands and feet clear of mechanism and all moving parts. Footrest must be completely closed before getting in or out of the chair. Only the occupant should operate the chair.
- Before moving or troubleshooting, unplug power cords from outlet and secure the mechanism to prevent unexpected movement of the chair.

3. Warning

- Weight Capacity: 350 lbs.
- Do not use outdoors. INDOOR USE ONLY.
- To avoid tip over, do not put your weight against the back of the chair.
- Do not stand, sit, or place extra weight on the arms, back or open footrest.
- Do not use this product if it is damaged. Do not use attachments or substitute parts.
- Avoid exposing upholstered chair to burning cigarettes or cigars, open flames, and high temperatures.

- Do not operate the unit until the back is installed and locked.
- Do not attempt to disassemble or repair the actuator or pump; no serviceable parts are inside.
- Do not allow electrical cord to be pinched between moving parts or between the frame and the floor. Do not place cord under carpet or in a location where it could become worn.
- Do not attempt to disconnect the power plug by pulling the power cord. Always hold the power plug and pull it out.
- Closely supervise children and disabled persons using this product.
- To reduce the risk of head entrapment and other injuries, keep children and pets away from openings and moving parts in and around furniture.
- This product has many moving parts, serious injury can occur if not used properly. Keep hands, fingers, and body parts away from the mechanism.
- To exit the unit safely and prevent a tripping hazard, bring the back upright and close the footrest.
- Place tables and area rugs at a distance to allow the footrest to fully extend without rubbing or interference.
- Check the condition of the power supplies, electrical cords, plugs, and connectors often. Keep the power supplies and electrical cords away from heat sources. Never operate the unit with a damaged power supply, electrical cord, plug or connector.
- Do not charge your device into the USB charge ports over 24hours.
- Do not charge any devices over 5V/2A with the USB charge ports.
- Do not overlay the USB charge ports with other heat-dissipating electronic products. This may prevent heat dissipation and cause overheating or melting.
- Unplug the power cord immediately if you detect strange odors or fumes coming from the chair.
- The chair is intended for a single occupant, not exceeding 350 pounds. Do not operate the chair with more than one occupant in or on any part of the chair.
- If you give this product to someone else, must include this owner's manual.

4. Symbols Information

The symbols below represent labels used on the product to identify warnings, mandatory actions, and prohibited actions. It is especially important for you to read and understand these symbols completely. Do not remove these labels from your product. Please note that not all the symbols may be used on your chair.



5. Disclaimer

Make sure you read and understand this manual completely before using your MCombo Product. We are not and cannot be held responsible for any damage or injury incurred due to improper or unsafe use of the MCombo Product. We specifically disclaim responsibility for any bodily injury or property damage that may occur during any use that does not comply with applicable federal, state, or local laws or ordinances.

II. ASSEMBLY INSTRUCTIONS

■ Notice

- Please read these instruction thoroughly before using.
- Do not plug the power supply in until assembly complete.
- Please contact us (See "MCombo Customer Support" on Page) immediately if anything is missing or damaged.

1. Product Parameters

Specification	Description
Model No	6160-HL128
Rated Voltage	100~240V
Rated Current	2A
Out put Voltage	29V
Overall Dimension	37"(W)*36.8"(D)*32.9"(H)
Reclining Angle	145°
Weight Capacity (Single)	350lbs
Package Quantity	3
Voltage	5V

2. Part List

● **Notice**

- Use MCombo parts only for all replacements.

Box 1 of 3

A Base x 1

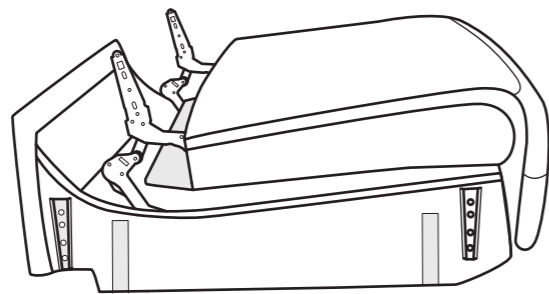

H



Hexagonal Screw x 4
spare x 2

J

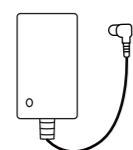

Power Adapter x 1
6160-FF-29V-Angle

K



Hex Key x 1

X

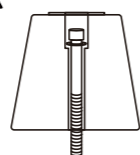

Wooden High Leg x4
6160-RS128H

Y



Support Leg x 4
6160-RS16A

Z



Anti-tipping Forward x 2

Box 2 of 3

E Backrest x 1

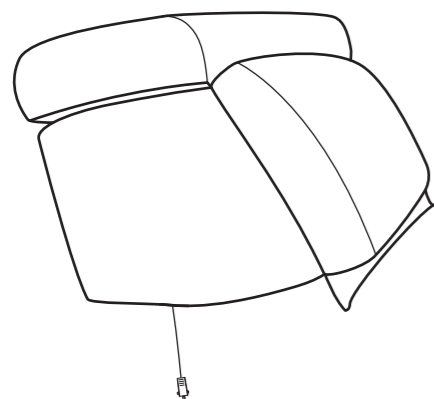

Box 3 of 3

C Left Armrest x 1

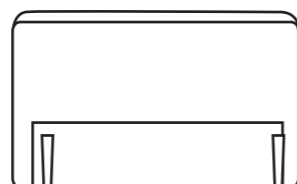

D Right Armrest with USB x1

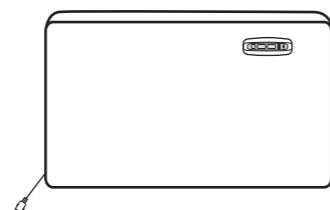

3. Assembly Steps

● **Notice**

- Use MCombo parts only for all replacements.

Step1 - Remove Protective Round Bar

Use the hex key to unscrew both ends of the iron bar and remove the iron bar.

■ **Notice**

Before assembly, please remove the protective round iron bar from the base brackets.

Please remove the protective round iron bar

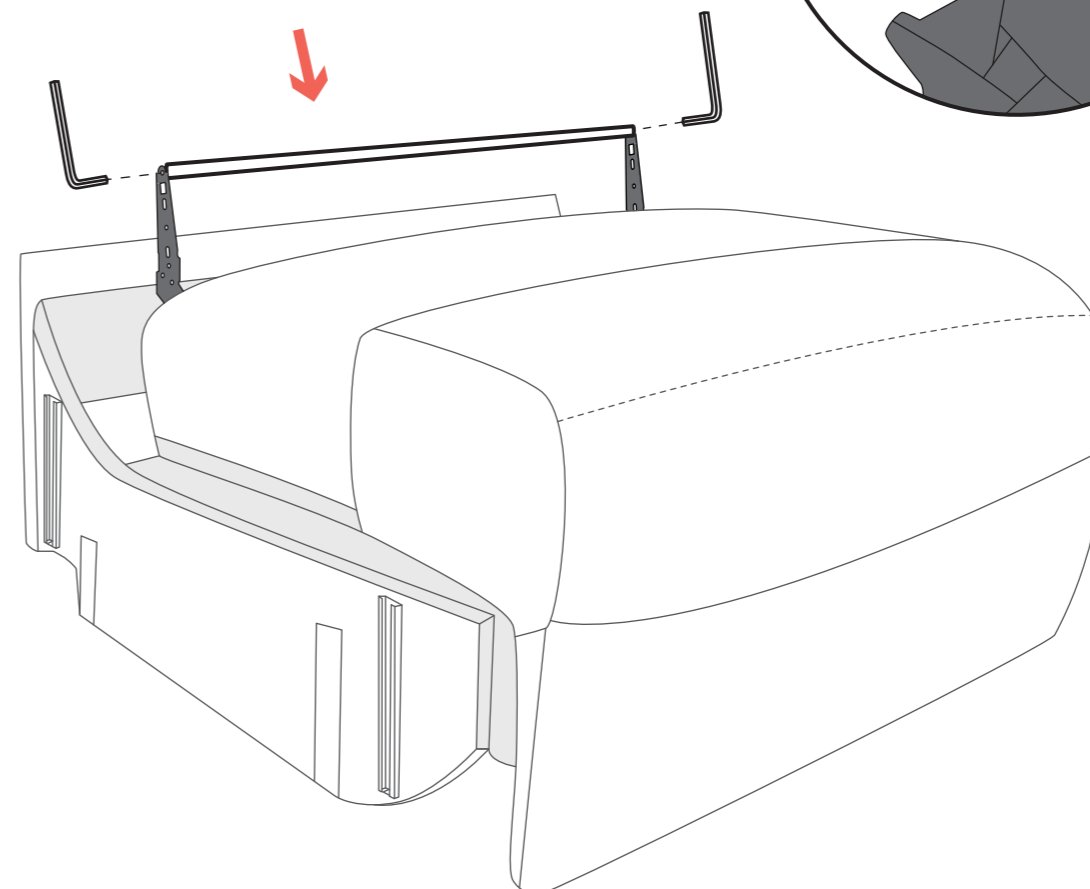

Step2 - Anti-forward-tipping Parts Assembly

1. Turn the two bases on the right side until the Step 3.
2. Screw one Anti-forward-tipping part into the two preset holes in the bottom inboard of the base. (Figure)

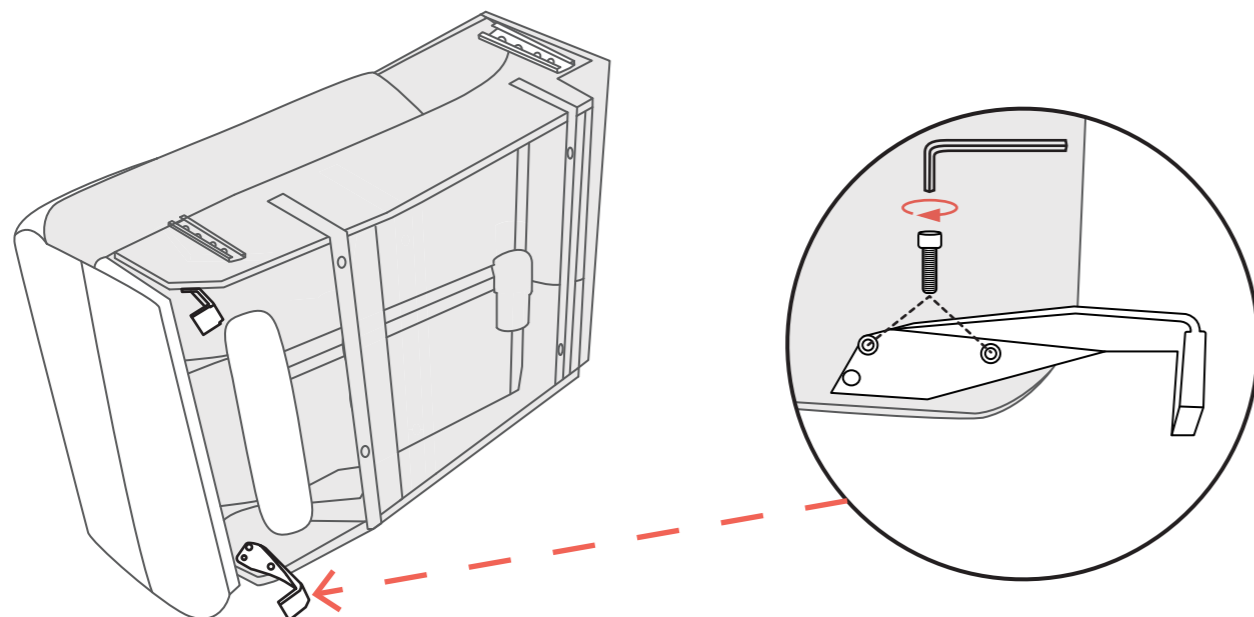

Step3 - Support Legs Assembly

1. Turn the base on its right side until the Step 3.
2. Screw the support legs into the preset holes in the bottom of the base.
3. Make sure four support legs are properly screwed in tighten and and ensure all legs do not move.

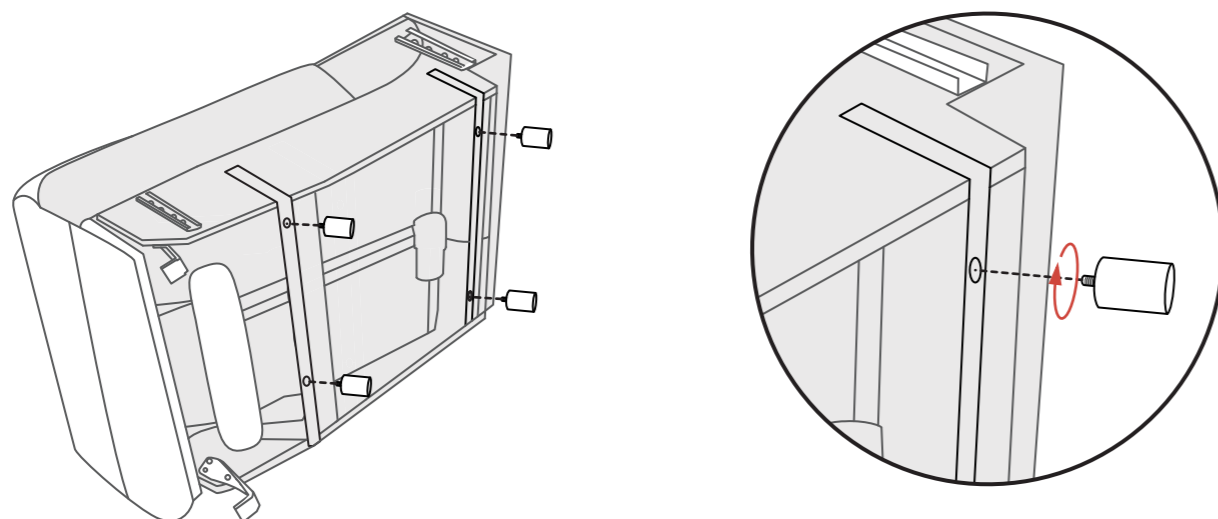

Step4 - Backrest Assembly

1. The headrest wire with the corresponding base wire interconnect.
2. Align the brackets of backrest at the clips of seat-back (Figure).
3. Push firmly the brackets into the seat-back. Listen for a "click" on each side to ensure the backrest is locked in properly.

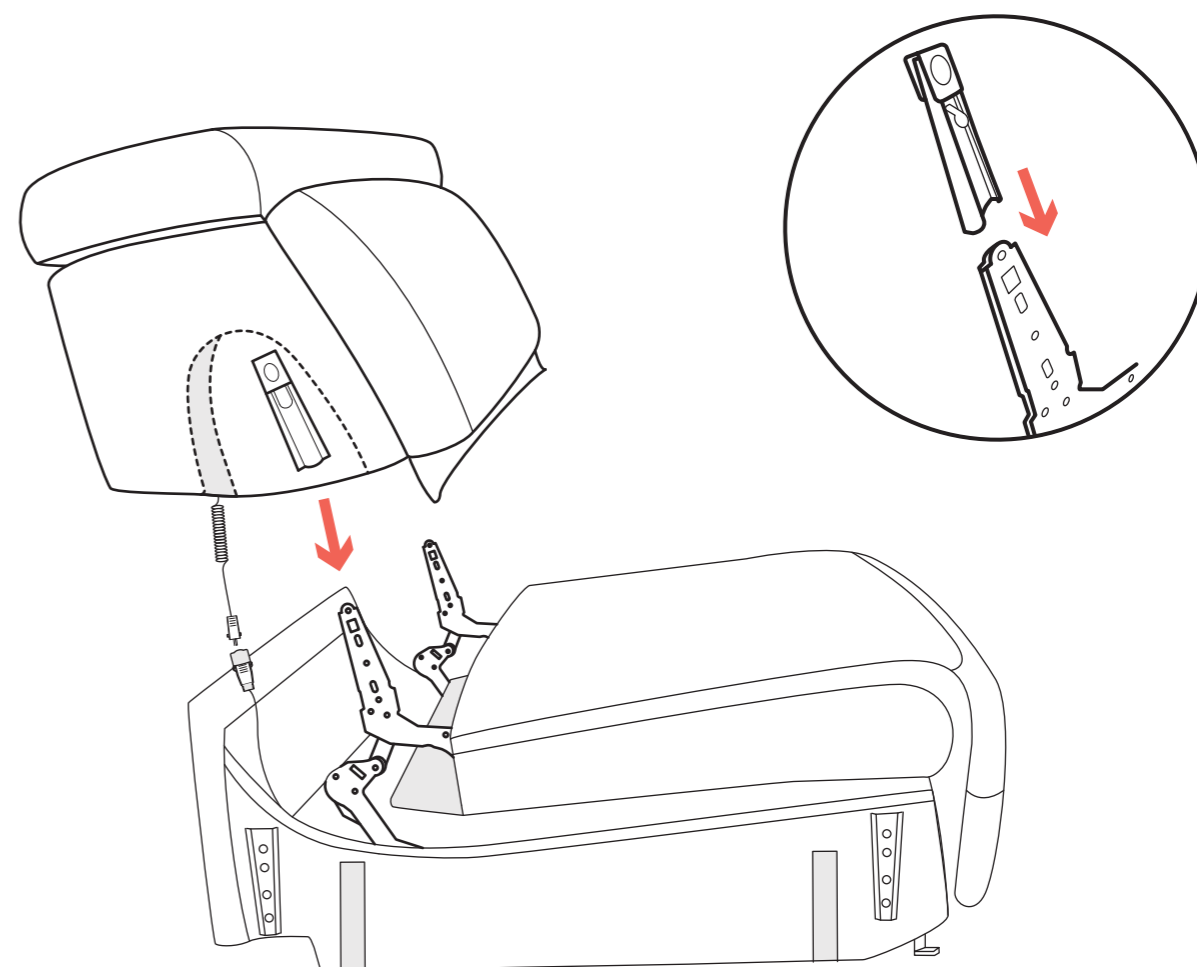

NOTE: Pull up the backrest to check if it is locked in place.

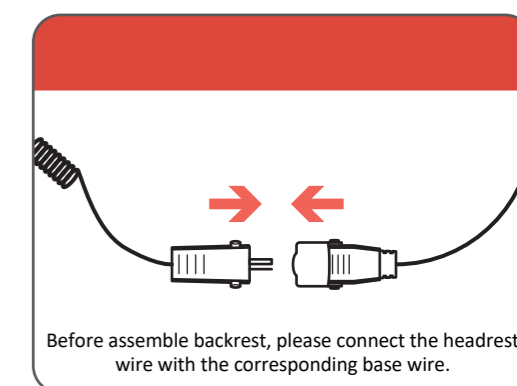

Step5 - Adjustable Support Legs Assembly

1. Turn the armrest upside down until the end of Step 5.
2. Screw the screw and gasket into the preset holes at the bottom of the armrest.
3. Make sure the screw is properly screwed in then tighten them.
4. Ensure the legs do not move.
5. Repeat above 4 steps for the other armrest.

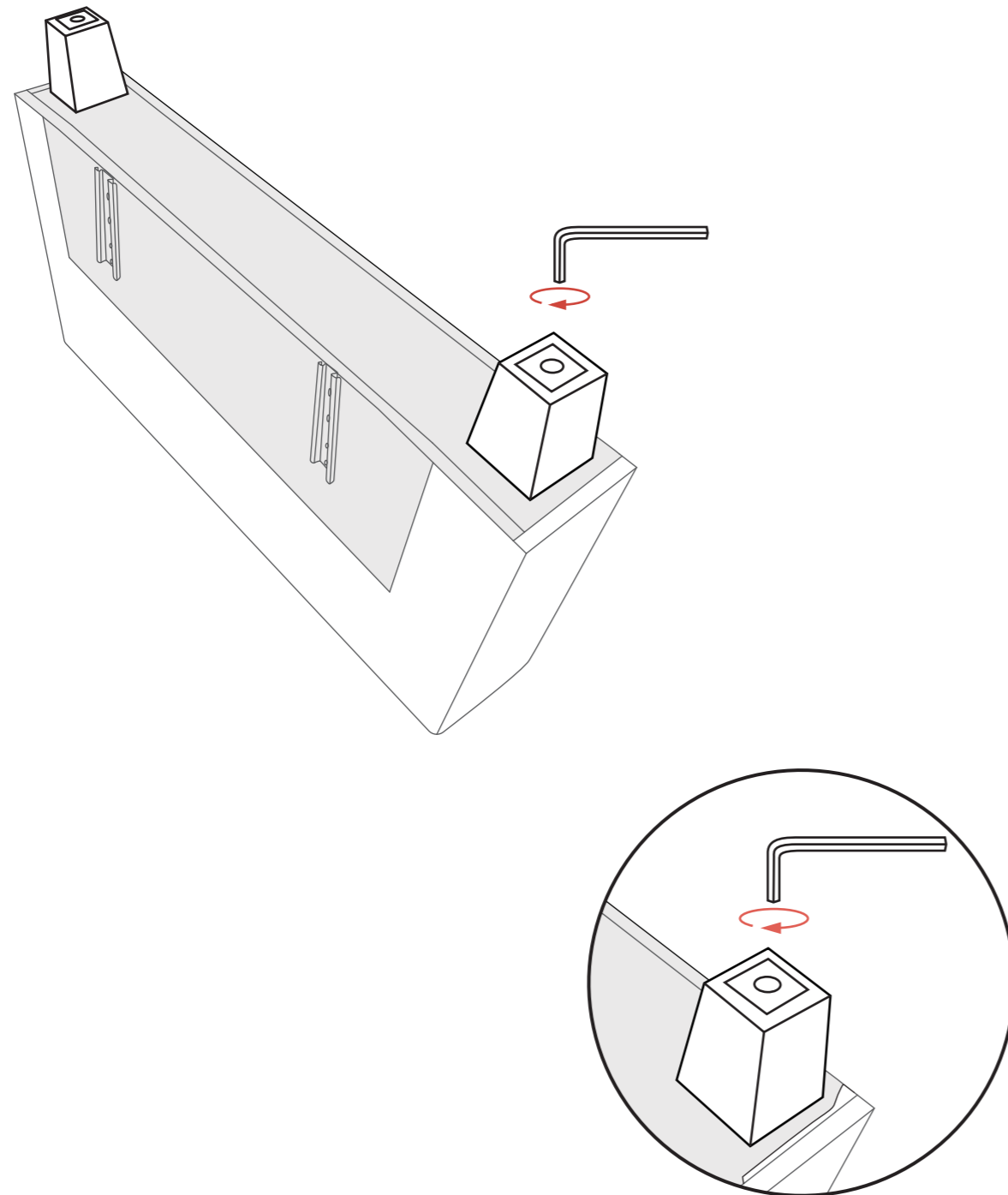

Step6 - Armrests Assembly

1. Ensure the armrest which has USB charge port is located on right of seat.
2. Slide the left and right armrest into the brackets of the seat.
3. Press each armrest down as far as it will go (Figure).

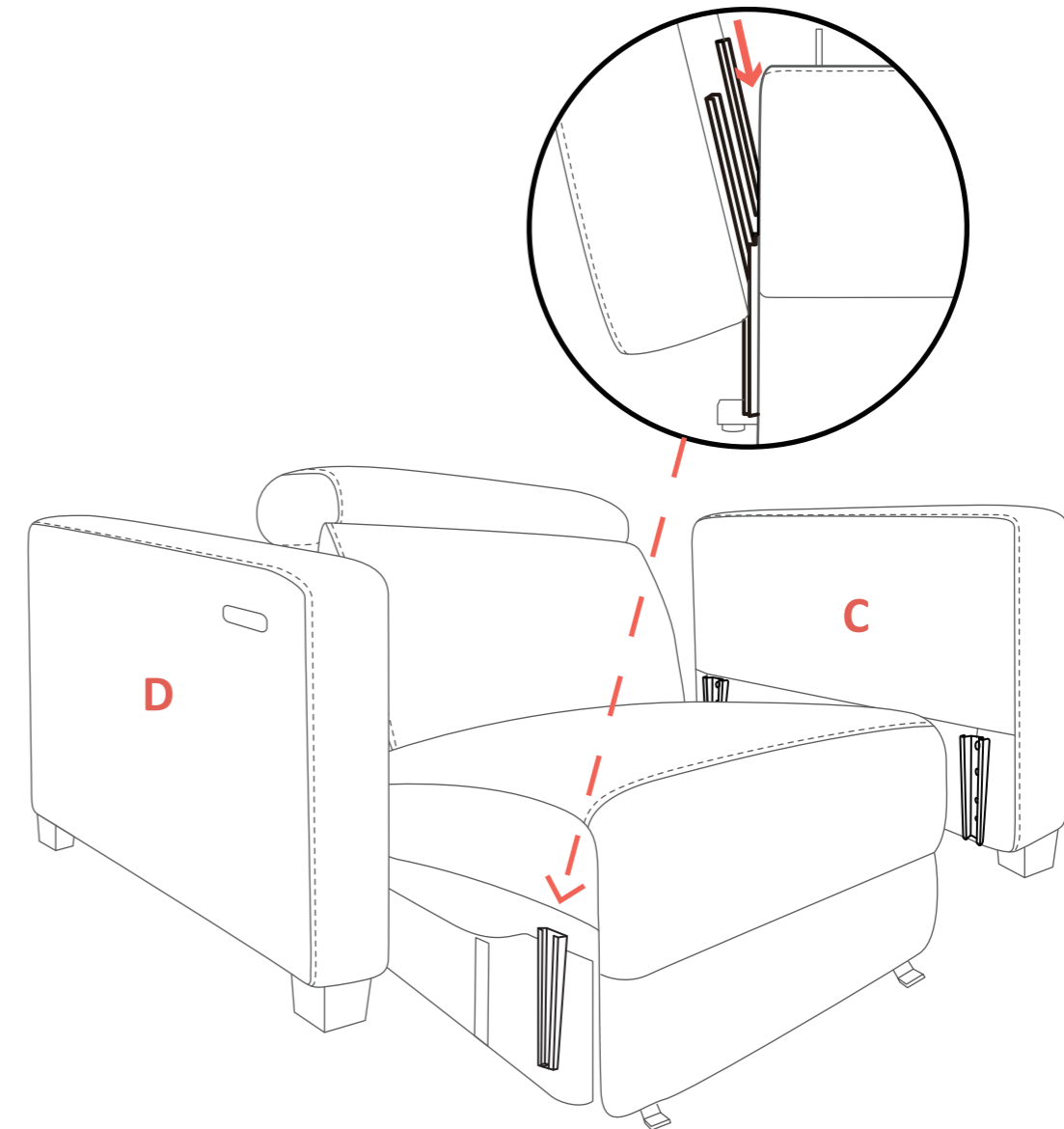

NOTE: Ensure the two connections on each armrest are both inserted onto the seat tightly.

ATTENTION

Ensure the two connections on each armrest are all inserted onto the seat tightly.

Step7 - Connections

Connect the recliner sofas according to the following wiring diagram (Figure).

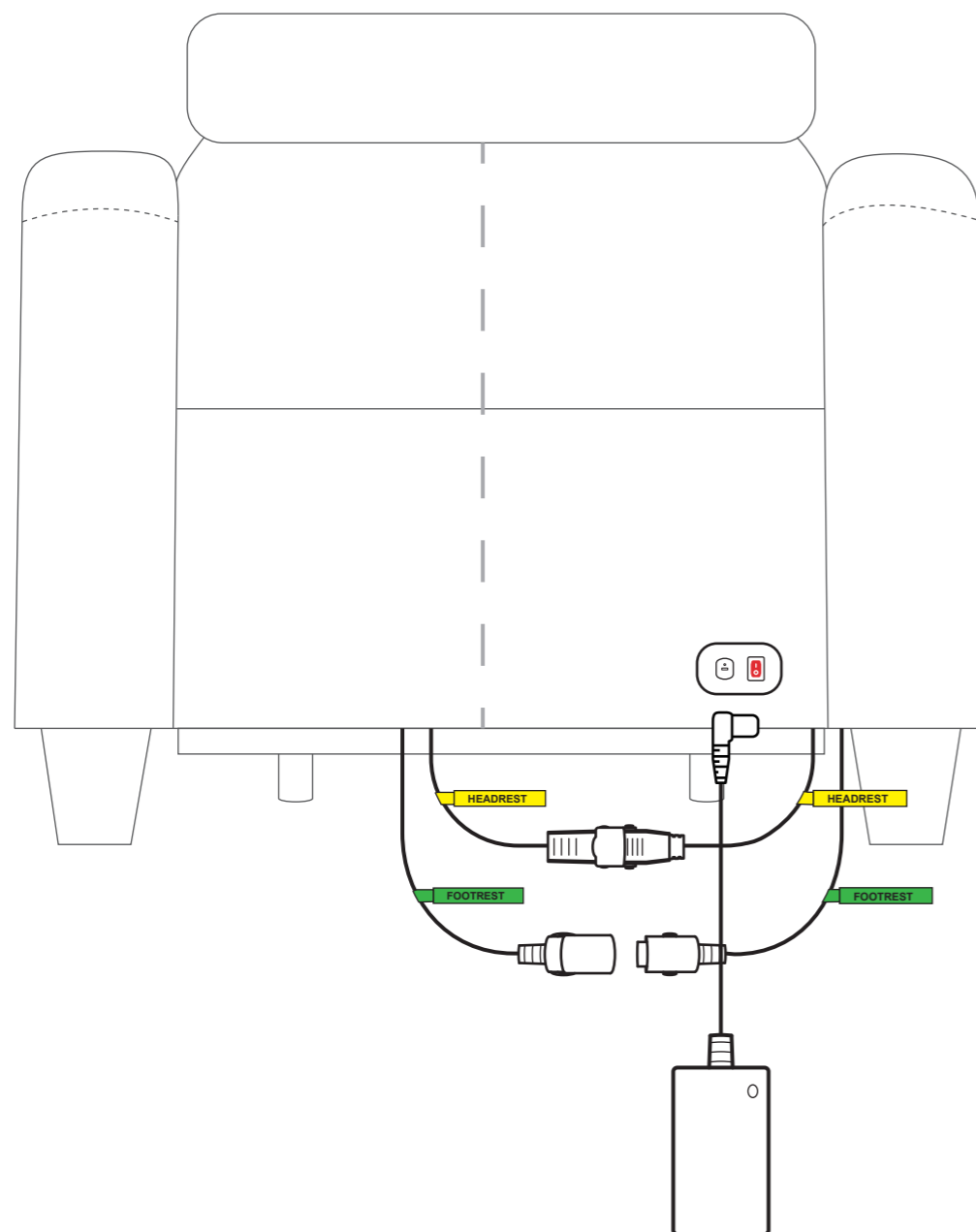

NOTE: The armrest wire needs to be wound under the base to avoid the wire is crushed by the rack frame (Figure).

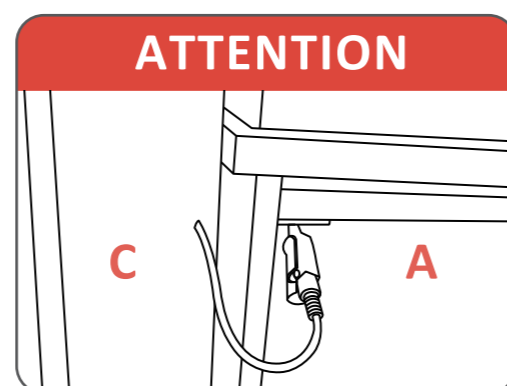

Step8 - Paste Velcro

1. Place the chair in the reclined position.
2. Pull out the Velcro in the gap between the base and the backrest and paste it well.

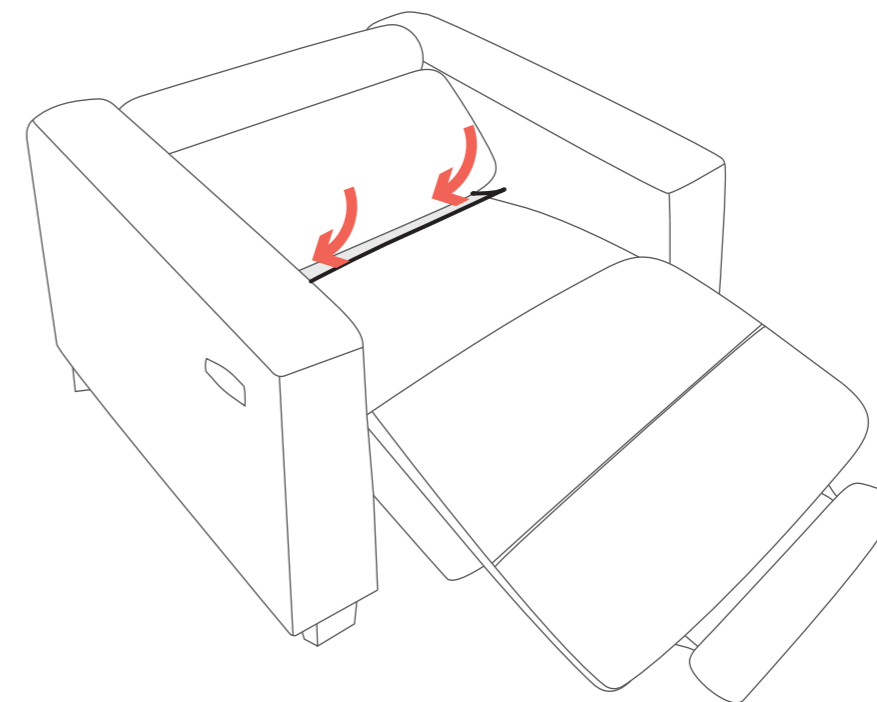

Step8 - Final Check

1. Make sure both metal brackets on each armrest are mounted on the base.
(There are two metal brackets on each side of the base, it looks like assembly finished when you insert armrest into only one bracket instead of two, however all pressure will apply to one bracket, that is one likely reason that the armrest falls apart from the base.)
2. Make sure the backrest inserts are locked to the base.
3. Make sure all wires are connected tightly.
4. Make sure all wires did not place the bottom of the rack and will not be pressed by frame.
(If the wire is pressed by the frame, the wire will be broken by the frame and the chair will stop working.)
5. Make sure all screws on four wooden high legs and four support legs are tightened.

III. OPERATING INSTRUCTIONS

1. Operation Precautions

- Do not use an extension cord.
- Do not exceed recommended weight limit.
- Do not use outdoors. INDOOR USE ONLY.
- Keep dry. Do not operate in a wet or moist environment.
- Keep all cords away from heated surfaces and pinch points.
- Do not use attachments not recommended by the manufacturer.
- Periodically check the control and all power cords for visible damage.
- Always leave the recliner in an upright and closed position when not in use.
- Do not use the footrest as a seat, or for purposes outside its intended use.
- Do not lean or apply downward force to the chair-back while in recline position.

NOTE:

If you discover a problem at any point during the setup and positioning of your power recliner sofa, stop and contact the MCombo Customer Support immediately. To avoid personal injury or product damage, do not plug the unit into the electrical outlet until the problem is corrected and do not attempt to fix electrical problems by yourself.

2. Operation Instruction

● **Control Buttons**

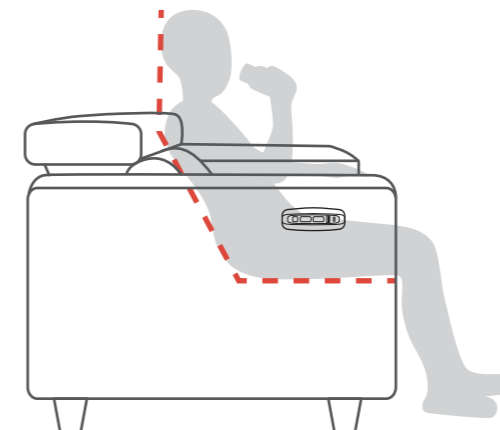
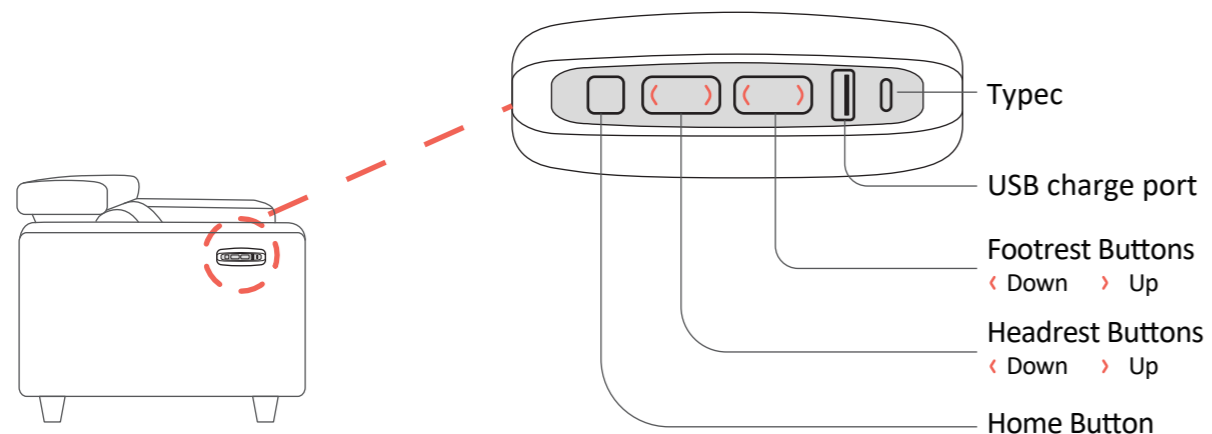

● **Seated**

When you want to take a short break, there is no need to operate the sofa you will get a comfortable experience.

● **Relaxing**

When you want to relax, adjust the footrest and headrest position.

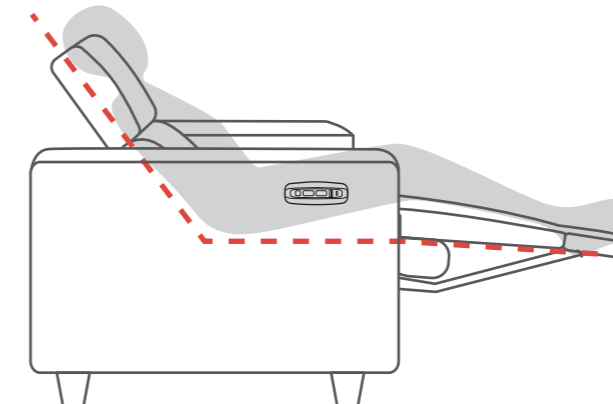
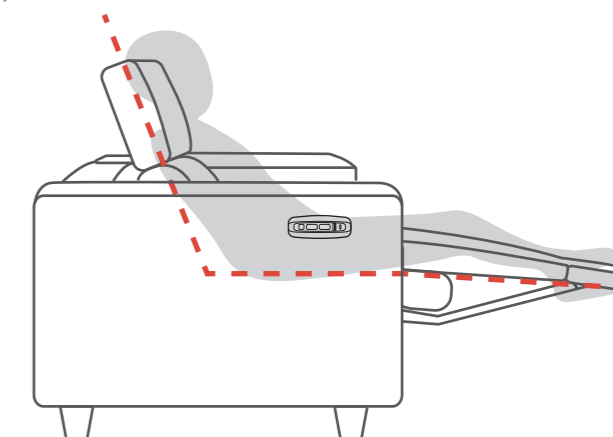

● **Napping**

When you want to take a nap, you can adjust the headrest to the right position while raising the footrest to relax.

● **Home Button**

When you want to get off, just press the **Home button**, and both the headrest and the footrest will return to original position.

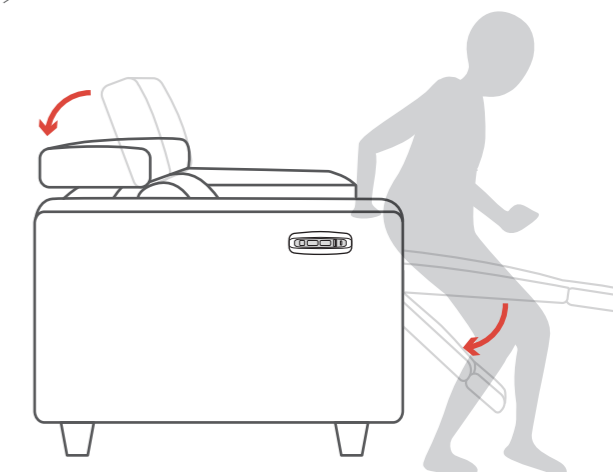

IV. CARE AND MAINTENANCE

Your MCombo product will provide years of superior performance and satisfaction with regular care and maintenance. To maintain the finish quality of your "assistant", please follow the guidelines and cleaning procedures provided below.

■ Notice

- Do not place your chair in direct sunlight, as sunlight causes fading.
- Do not smoke cigarettes while seated in or using your chair.
- Avoid extreme changes in temperature by arranging chair away from radiators, heat and air vents.
- Do not use solvent-type cleaners to spot clean.
- Do not saturate fabric.
- Please be careful that pet scratch may cause fabric or leather break.

1. Fabric Care

- Inspect the fabric on a regular basis for any pulls, tears, or gaps.
- Frequent vacuuming or light brushing with a nonmetallic, stiff bristle brush to remove dust and grime is recommended.
- When liquid spills onto the fabric, please immediately wipe off liquid spills with a dry or lightly dampened clean white cloth, sponge, or paper towel.

2. Faux Leather Care

- Wipe leather down regularly with a clean, dry microfiber cloth.
- For more stubborn dust, dampen the cloth with distilled water. Make sure that the cloth is not soaking wet. Never let water soak into leather.
- Always be sure to use a soft cloth and never use an abrasive brush or scrubber as this can scratch and damage the leather.

3. Electronics Care

- Inspect all wiring harnesses to make sure they are not damaged or stuck under chair.
- Keep all the electronics free from moisture and temperature extremes.
- Check electrical components frequently for signs of corrosion and replace as necessary.
- Contact MCombo Customer Support if damage is present, do not fix it by yourself.

4. Disposal & Recycling

Your power recliner sofa must be disposed of according to applicable local and national statutory disposal regulations. Contact your local waste disposal agency for information on proper disposal of recliner sofa packaging, metal/wood frame components, fabric, electronic components.

V. TROUBLESHOOTING

The following troubleshooting FAQs should summarize what you need to know about your power recliner sofa.

Questions	Answers
What if my power recliner sofa does not operate at all?	<ul style="list-style-type: none"> • Make sure all the connections at the bottom of the chair are secured; refer to the Assembly Instructions. • Check all the electrical cords are not crimped or pinched. • Check if the GREEN light on the power adapter is on. • Check if the light of the RED button at the back of the base is on. • Make sure the light of the control buttons on the right armrest goes on.
What if the reclining function doesn't work?	<ul style="list-style-type: none"> • Make sure the light of the control buttons on the right armrest goes on. • Check the electrical cords of the motor on the base are not crimped or pinched. • Check the rack frame of the recliner sofa is not broken.
What if the headrest function doesn't work?	<ul style="list-style-type: none"> • Make sure the light of the control buttons on the right armrest goes on. • Check the electrical cords of the motor on the backrest are not crimped or pinched. • Check the motor of the backrest are not broken.

Questions	Answers
What if the USB charge ports do not work?	<ul style="list-style-type: none"> • Make sure all the connections at the bottom of the chair are secured ; refer to the Assembly Instructions. • Check all the electrical cords are not crimped or pinched. • Check if the light of the control buttons on the right armrest goes on.
What if the armrest falls apart from base?	<ul style="list-style-type: none"> • Ensure the two connections on each armrest are all inserted onto the base tightly. • Check the brackets of armrest and base to ensure there is no defects.
What if my recliner sofa makes a clicking noise?	<ul style="list-style-type: none"> • Check the motor and make sure the end of motor at the center of pivot point. • Make sure the weight capacity of 350 lbs has not been exceeded.
What if my recliner tilted to one side?	<ul style="list-style-type: none"> • Make sure the rack of recliner sofa is in a good condition without any distortion.

VI. DISASSEMBLY INSTRUCTION

■ Notice

- Ensure the chair is in upright position and its footrest and headrest return to original position.
- Please unplug the power adapter before disassembling.
- Please dismantle the power recliner sofa in strict accordance with the order in which they were dismantled.

Step1 - Disconnect all Connections

Please disconnect all connections on the chair base and backrest before disassembling.

Step2 - Disassemble Armrests

1. Use your knees to find a support point on the seat and press on the base with your own strength.
2. Hold the two marked positions at the bottom of the armrest and lift the armrest vertically upward.(Refer to arrow direction and the circular marking area.)

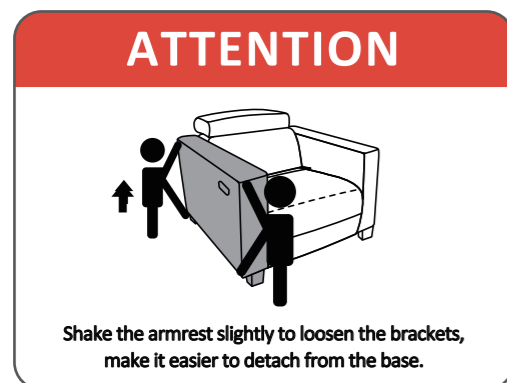
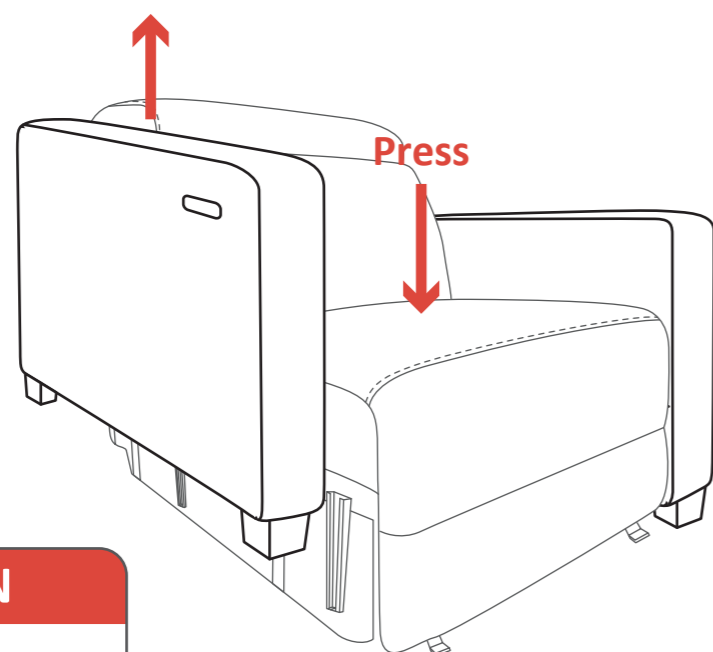

Step3 - Disassemble Backrest and Anti-forward-tipping

1. Pushing the metal ears of the bracket inserts outward (Refer to arrow direction.)
2. After unlocking the metal lugs on both sides of the backrest hold the bottom part of the backrest marked in the picture below and pull it vertically upward.
3. Unscrew the anti-forward-tipping part out of the preset holes at the bottom of the inside of the base. (Figure)

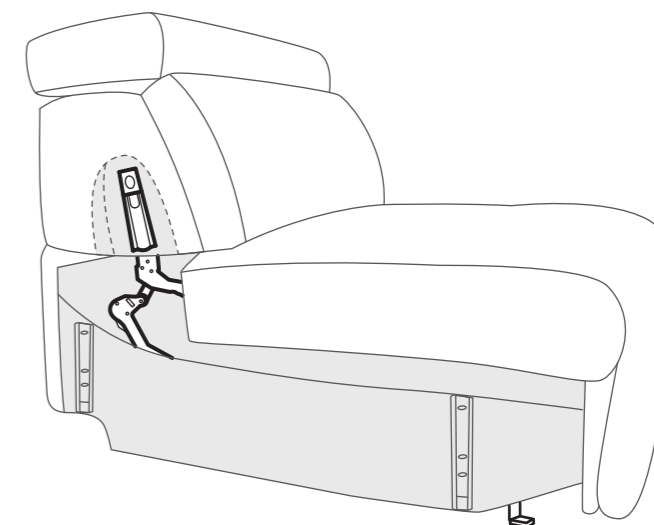
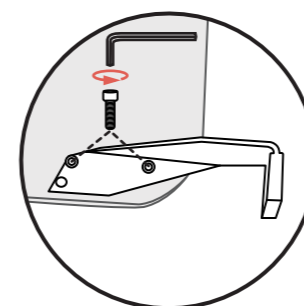
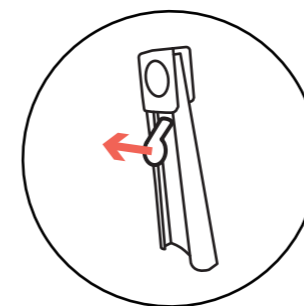

Step4 - Disassemble Legs

Please use Hex key to remove four wooden high legs and four support legs.

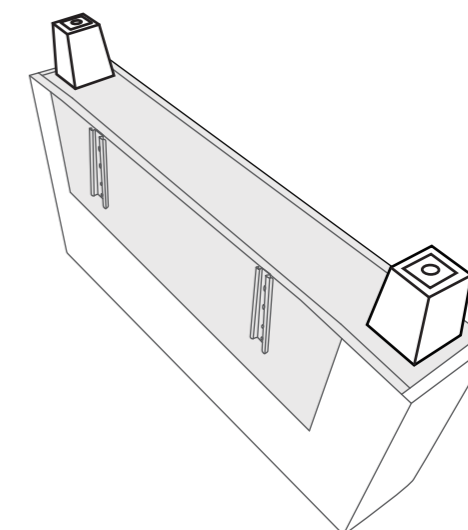
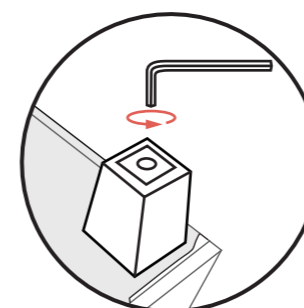

NOTE:

- If the chair needs to be returned, please pack all screws, feet, power supply and other accessories into the box.
- Please refer to the 5-page part list and 22-page return for other packing methods.

VII. WARRANTY

■ Notice

- For product beyond the limited manufacturer warranty period and scope, MCombo® can also provide replacement service, but a basic charge will be charged according to the circumstances.
- The warranty only applies to MCombo® products and does not include any accessories or enhancements.
- Warranties are only valid in the 48 contiguous United States and are contingent upon the consumer operating the product according to the corresponding instruction manual.

Reclining Mechanism	★ 2 Years
Upholstery Material	★ 2 Years
Metal/ Wood Chair Frame	★ 2 Years
Electronic Parts	★ 2 Years

CONSUMER WARRANTY LIMITATIONS AND EXCLUSIONS

All warranties begin on the date of delivery.

All warranties are to the original purchaser from MCOMBO® ONLY.

- MCOMBO® will replace the defective parts or send replacement product provided that the warranty parts have not been subjected to misuse, abuse or improper service by the consumer, for example, damaged wire arising in consequence of negligence or improper operation.
- Exclusions also include components with damage caused by:
 - Contamination
 - Abuse, misuse, accident, or negligence
 - Commercial use, or use other than normal
 - Improper operation, maintenance, or storage

NOTE:

MCOMBO® will pay standard shipping rates on all warranted parts for two years. We can also sell you replacement part for a discount price when your product is out of warranty policy.

VIII. RETURN/ REPLACEMENT POLICY

■ Notice

Why don't we recommend returning the item by yourself?

- Huge cost- UPS/FedEx oversize fee.
- Need you to take the box to UPS/FedEx facility.

Return/ Replacement Policy

MCOMBO®

All of product come with a 30-day return/replace policy. During this time, we will cover the shipping cost of return and replacement for defective and damaged product, through providing pre-paid return label or pick-up service for customer convenience.

NOTE:

- Please keep the original packaging in case the product needs to be returned. If the original packaging is not available, the newly found packaging needs to meet the following size standard:
UPS/FedEx packaging size standard: (width+ height) * 2+ length < 128 inch.
- Please disassemble the product before you return it, otherwise there will be a huge cost as oversized and it could even exceed your order amount.
- Please do not purchase return label for a damaged/defective product by yourself.
- If you have any problem to return the product, please contact us immediately, we will do our best to help you with a reasonable solution.

