

INSTALLATION INSTRUCTION

BLADE

WARNING

IMPORTANT: NEVER attempt any work without shutting off the electricity.

- Read all instructions before installing.
- System is intended for installation by a qualified electrician in accordance with the National Electrical Code and local regulations.
- Go to the main fuse box, or circuit breaker. Place the main power switch in the "OFF" position and unscrew the fuse(s) or switch "OFF" the circuit breaker switch(es) that control the power to the fixture or room that you are working on.
- Place the wall switch in the "OFF" position.

CAUTION

- All parts must be used as indicated in these instructions. Do not substitute any parts, leave parts out, or use any parts that are worn out or broken. Failure to follow this instruction could invalidate the ETL/CETL listing of this fixture.
CAUTION When handling the fixture, do not apply pressure to the LEDs. Hold the fixture by the base only.

AVERTISSEMENT

IMPORTANT : Coupez l'électricité avant TOUTE manipulation.

- Lisez toutes les instructions avant d'installer.
- Système est destiné à être installé par un électricien qualifié en conformité avec le code national de l'électricité et les règlements locaux.
- Accédez au panneau central de disjoncteurs ou de fusibles de votre demeure et placez l'interrupteur principal en position d'arrêt (« OFF »).
- Placez l'interrupteur mural en position d'arrêt (« OFF »).

MISE EN GARDE

- Toutes les pièces doivent être utilisées tel qu'il est indiqué dans ces instructions. Ne remplacez pas les pièces, n'en laissez pas de côté et ne les utilisez pas si elles sont usées ou brisées. Le non-respect de ces instructions peut annuler l'homologation ETL/CETL du luminaire. MISE EN GARDE Ors de la manipulation de l'appareil, ne pas appliquer de pression à la LED, tenir l'appareil par la seule base.

ADVERTENCIA

IMPORTANTE: NUNCA intente hacer trabajos sin desconectar el suministro eléctrico.

- Lea y comprenda todas las instrucciones e ilustraciones por completo antes de proceder con el ensamblaje e instalación de esta lámpara.
- Sistema está diseñado para ser instalado por un electricista calificado, de acuerdo con el código eléctrico nacional y las normas locales.
- Diríjase a la caja de fusibles o a la caja del interruptor de circuito principal en su hogar. Coloque el interruptor de alimentación principal en la posición "OFF" (APAGADO).
- Coloque el interruptor de la pared en la posición "OFF" (APAGADO).

PRECAUCIÓN

- Todas las piezas deben usarse como lo indican estas instrucciones. No reemplace las piezas, no omita piezas durante la instalación ni utilice piezas gastadas o rotas. El incumplimiento de esta indicación podría invalidar la calificación ETL/CETL esta lámpara. PRECAUCIÓN Al manipular el aparato, no aplique presión a los LED, mantenga el aparato en la base sólo.

HARDWARE



P3 Wire Connector
Qty: 3pc



Junction Box Screw
Qty: 2pc + 1 Extra



Set Screw
Qty: 4pc + 1 extra



Fixture Screw
Qty: 2pc + 1 extra

INSTALLATION INSTRUCTION

BLADE

PREPARATION

1. Shut off the power at the circuit breaker and remove existing fixture, including the mounting hardware.
2. Carefully unpack your new fixture and lay out all the parts on a clear area. Be careful not to lose any small parts necessary for installation.
3. Remove the mounting screws (C1) from the fixture.
4. Connect the electrical wires as shown in **Fig. 3**, making sure that all wire connectors are secured. Fixture and junction box ground wires should be connected to mounting plate using green screw provided. After wires are connected, tuck them carefully inside the junction box.

MOUNTING THE FIXTURE

For Junction Box (**Fig.1**)

- Secure the mounting ring (D1) to the junction box (F1) using junction box screws (B1). Make sure the two holes (spacing 2-3/4") are vertical direction as shown in **Fig. 1**.
- Put the mounting plate (E1) and the conversation plate (G1) onto the mounting ring (D1). Make sure the two holes on mounting plate (E1), the two slots on conversation plate (G1) and the two holes (spacing 2-3/4") are aligned. Fasten them using screws (I1).

For Switch Box (**Fig.2**)

- Secure mounting plate (E1) to the switch box (F1) using screws (B1). The side of the mounting plate marked "GND" (E1) must face out.
5. Place the fixture back plate (H1) over the mounting plate (E1) and secure with screws (C1).

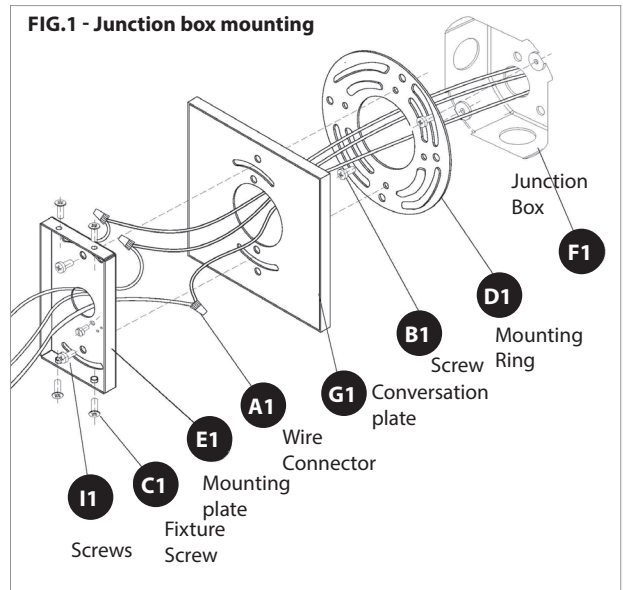

FIG.2 - Switch box mounting

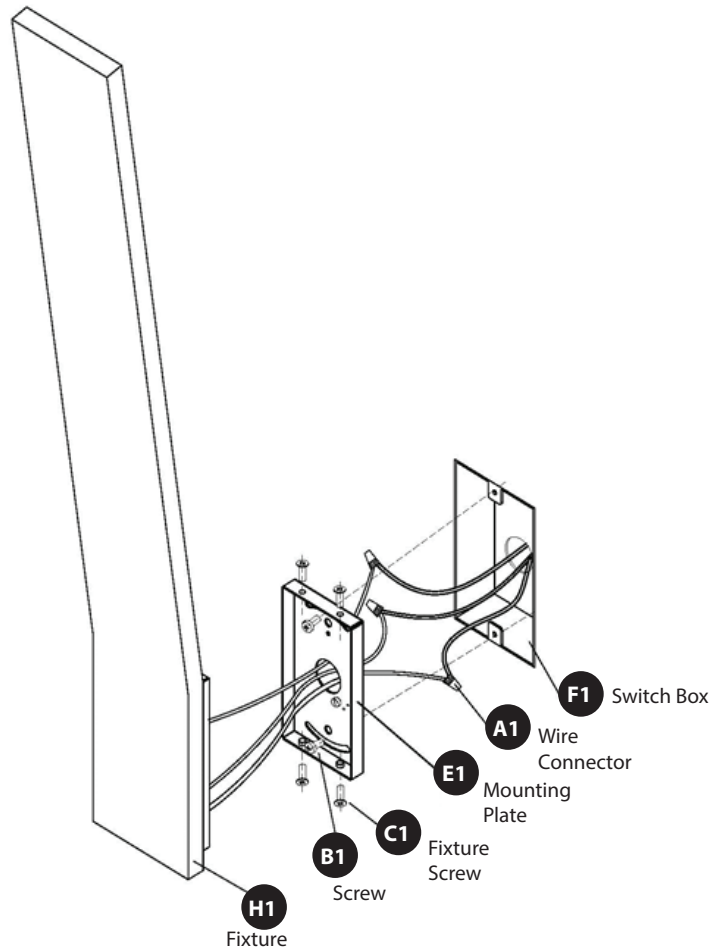

Fig.3 Wiring

Fixture Wires	House Wires
Black or Smooth	Black (Hot)
White or Ribbed	White (Neutral)
Bare wire (Ground)	Green or Bare Copper (Ground)

