

ASSEMBLY INSTRUCTIONS

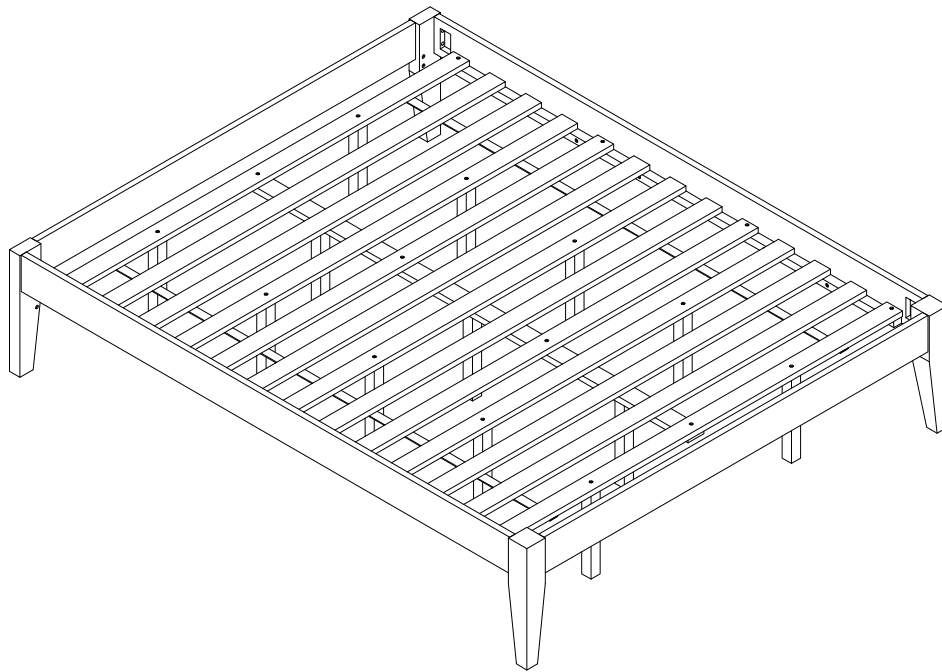

Fine Furniture for every stage of life

Eastern King Universal Platform Bed

REVISION 0 : 12/26/2015
REVISION 1 : 01/10/2020

ASSEMBLY INSTRUCTIONS

ASSEMBLY TIPS:

1. Remove hardware from box and sort by size.
2. Please check to see that all hardware and parts are present prior to start of assembly.
3. Please follow attached instructions in the same sequence as numbered to assure fast & easy assembly.



WARNING!

1. Don't attempt to repair or modify parts that are broken or defective. Please contact the store immediately.
2. This product is for home use only and not intended for commercial establishments.

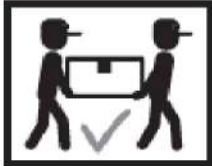

ASSEMBLY TIME



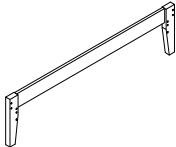

10 MINUTES

PARTS IDENTIFICATION

B1 (BOX 1)

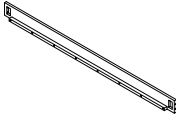

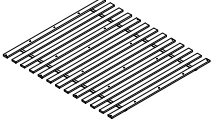



A	HEADBOARD		1PC		B	FOOTBOARD		1PC
---	-----------	---	-----	--	---	-----------	---	-----

B2 (BOX 2)

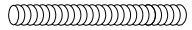
C	BED RAIL		2PCS		F	BED SLAT SUPPORT WITH LEVELER		10PCS
D	ROLL SLAT (13PCS)		1SET		G	CENTER RAIL SUPPORT WITH LEVELER		3PCS
E	CENTER RAIL		1PC					

HARDWARE IDENTIFICATION

BOX2 - HARDWARE PACK

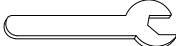
1	THREADED BOLT (5/16 x 90mm - RBW)		8PCS		5	BOLT (1/4 x 35mm Φ 12L4 - RBW)		13PCS
2	HEX NUT (5/16 x 12mm - RBW)		8PCS		6	ALLEN WRENCH (4 x 58MM - RBW)		1PC
3	FLAT WASHER (8/16 x 1.5mm - RBW)		8PCS		7	FLAT HEAD SCREW (4 x 30mm - RBW)		12PCS
4	WRENCH (12mm - RBW)		1PC					

NOTE:

Phillips head screw driver is required in the assembly process; however, manufacturer does not provide this item.

ASSEMBLY INSTRUCTIONS

STEP 1

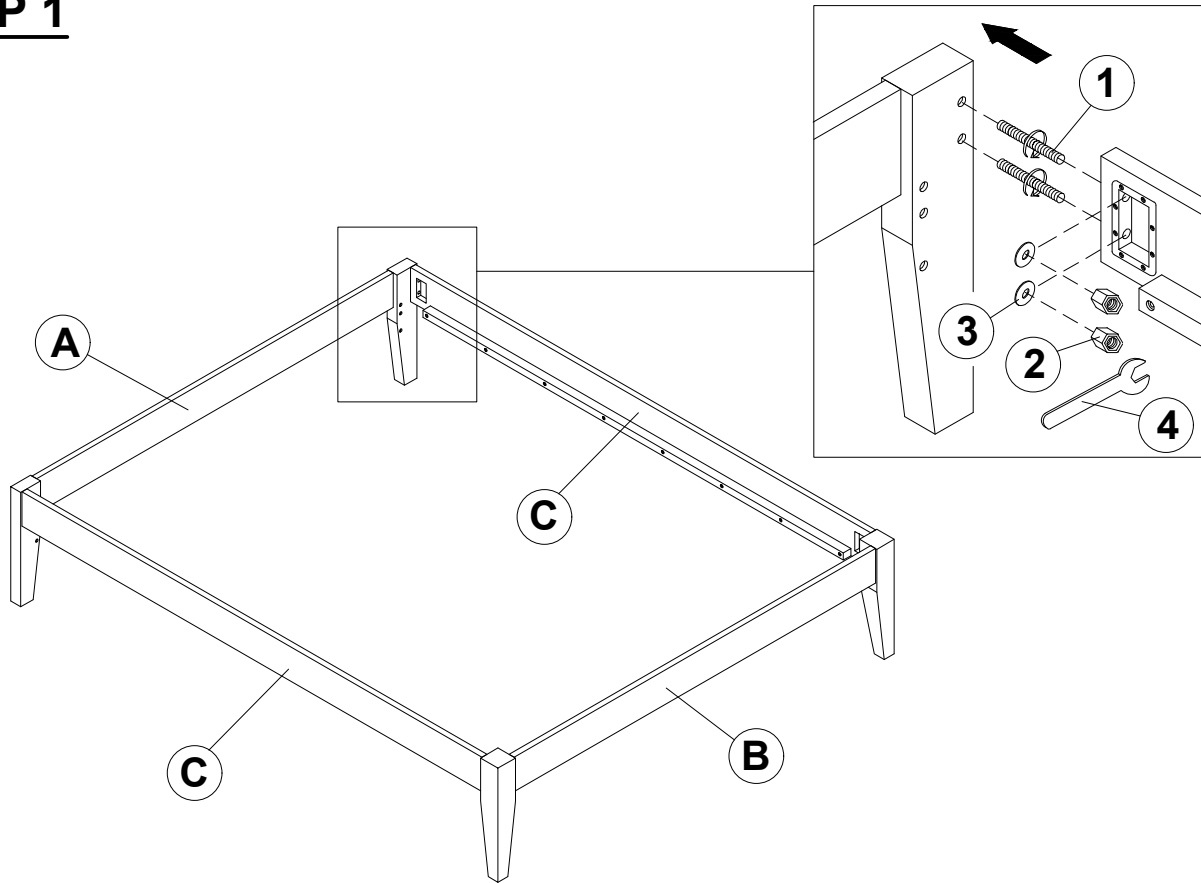

STEP 2

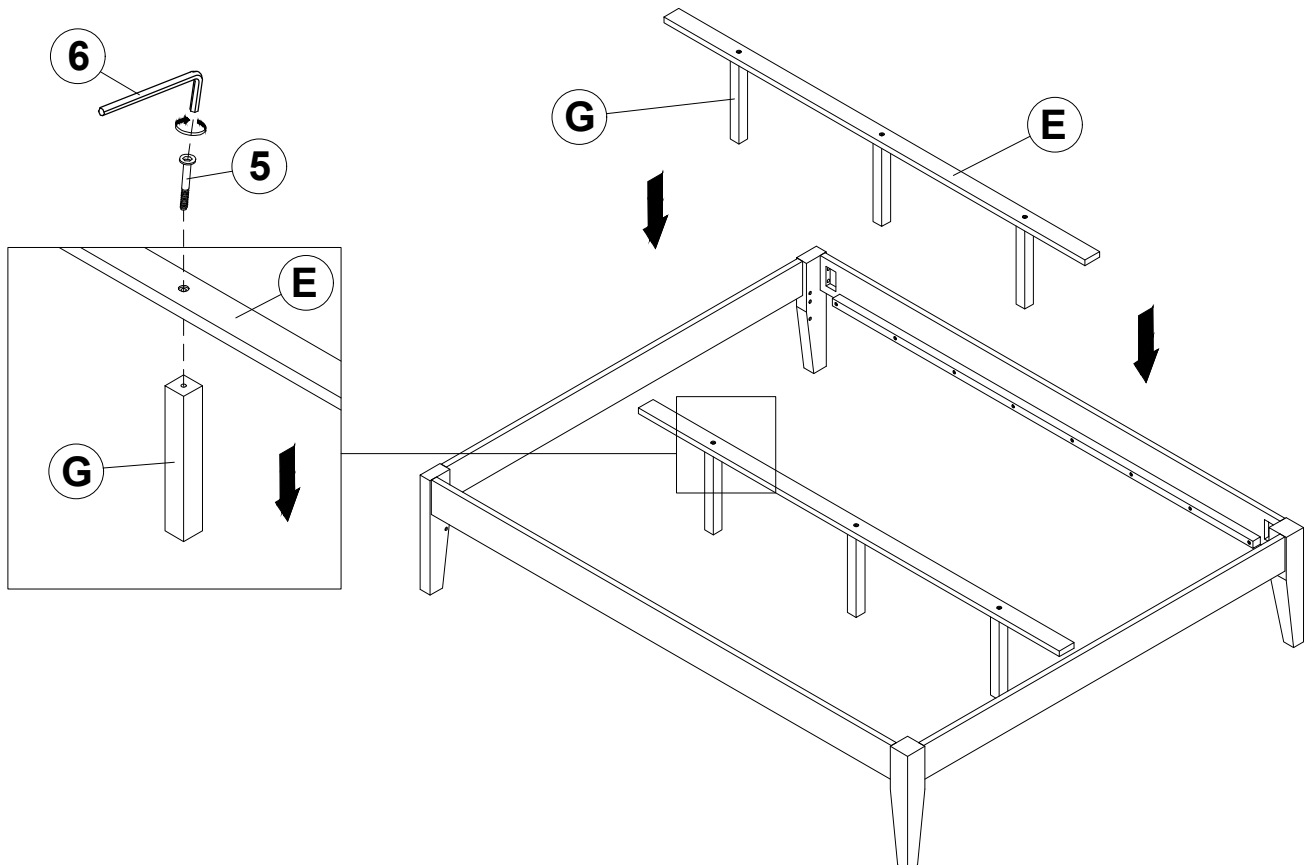

ASSEMBLY INSTRUCTIONS

STEP 3

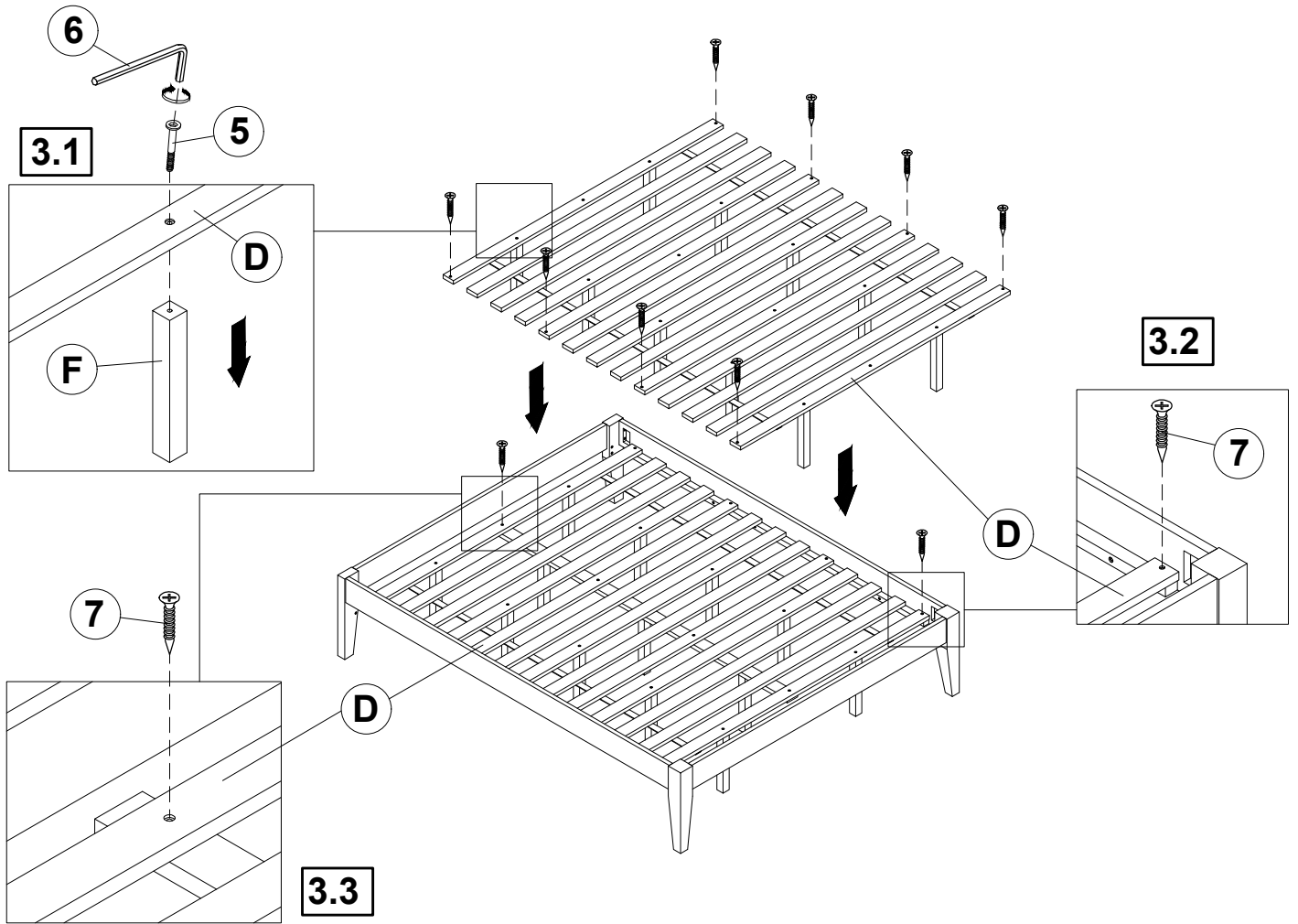

STEP 4 COMPLETE

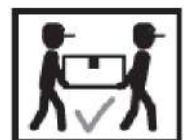
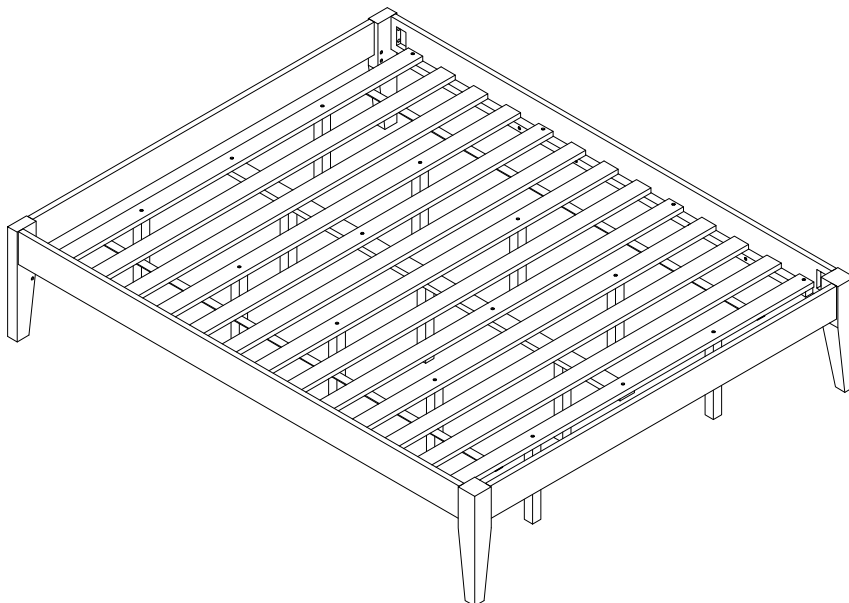

Inner Size : 77.50"W X 81.00"D

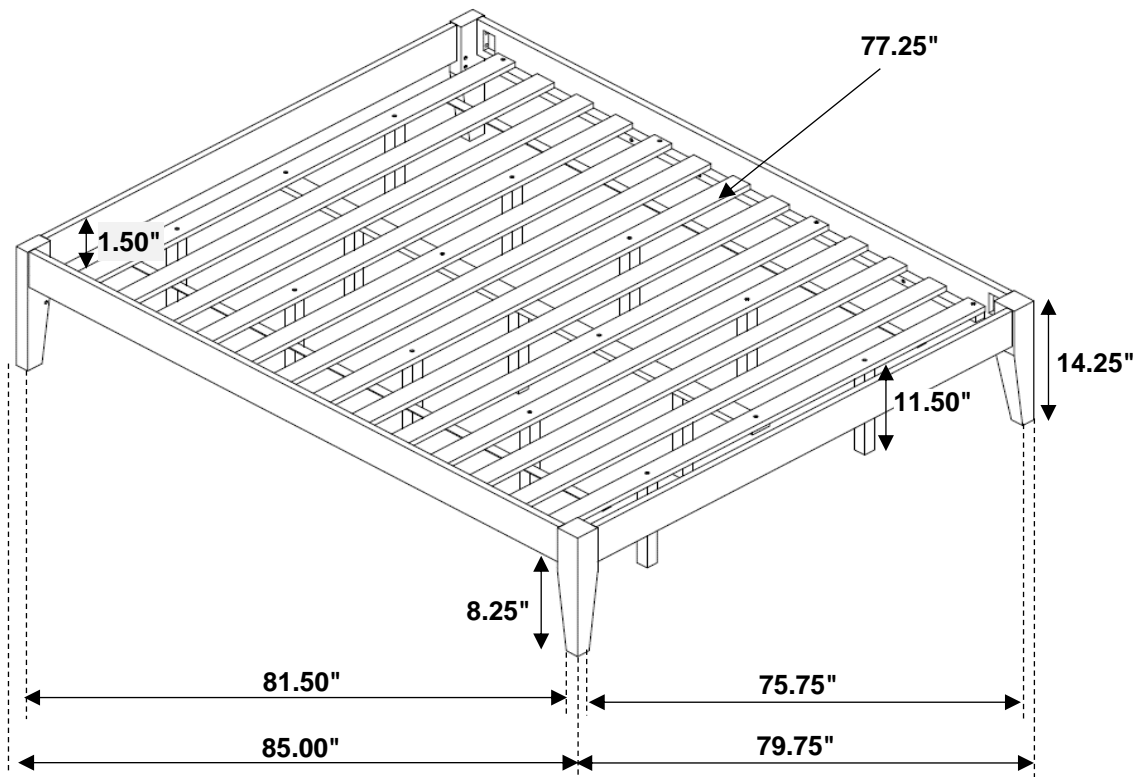

Note: Dimension tolerance $\pm 5\%$