

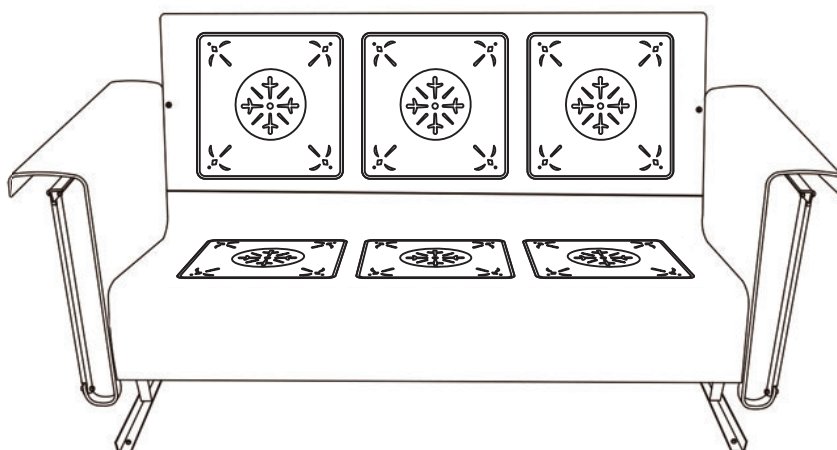







CROSLLEY

FURNITURE

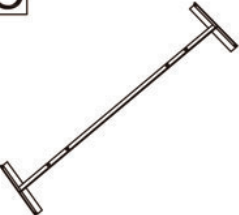

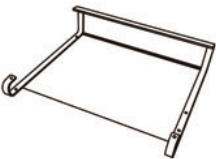





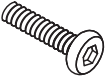

Sofa Glider
CO1034



PART LIST

A 	B 	C 	D 	E 
Left Leg 1 PC	Right Leg 1 PC	Leg Support 1 PC	Support 2 PCS	Connecting Wire 2 PCS
F 	G 	H 	I 	
Left Arm 1 PC	Right Arm 1 PC	Back Panel 1 PC	Seat Panel 1 PC	

HARDEARE LIST

#1 	#2 	#3 	#4 	#5 
M6x25mm Long Bolt 6 PCS(Extra 1)	M6x20mm Medium Bolt 2 PCS(Extra 1)	M6x16mm Short Bolt 19 PCS(Extra 3)	Self-Locking Nut 29 PCS(Extra 3)	Metal Washer 60 PCS(Extra 3)
#6 	#7 	#8 	#9 	#10 
Plastic Washer 8 PCS(Extra 2)	Adjustable Leveler 4 PCS(Extra 1)	Connecting Screws 2 PCS(Extra 2)	Wrench 2 PCS	Allen Wrench 1 PC
#11 				
Touch Up Paint 1 PC				

IMPORTANT NOTE: WE RECOMMEND AT LEAST TWO PEOPLE WORK TOGETHER TO ASSEMBLE UNIT.

Step 1. Screw adjustable levelers (part #7) into pre-drilled holes on the bottom of legs (parts A B).

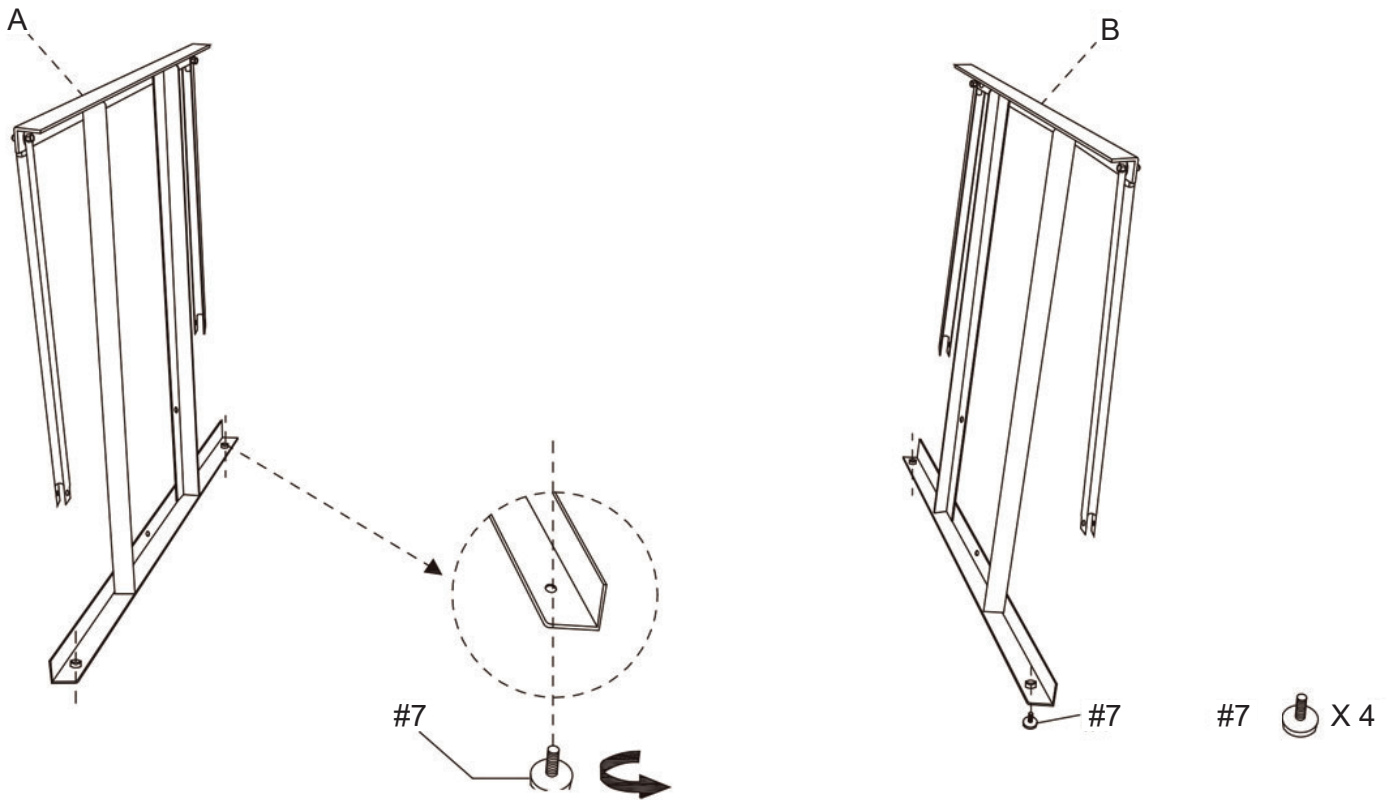

Step 2. Attach leg support (part C) to legs (parts A B) using short bolts (part #3), metal washers (part #5), self-locking nuts (part #4), wrench (part #9) and allen wrench (part #10).

NOTE: Please do not fully tighten bolts until unit is fully assembled.

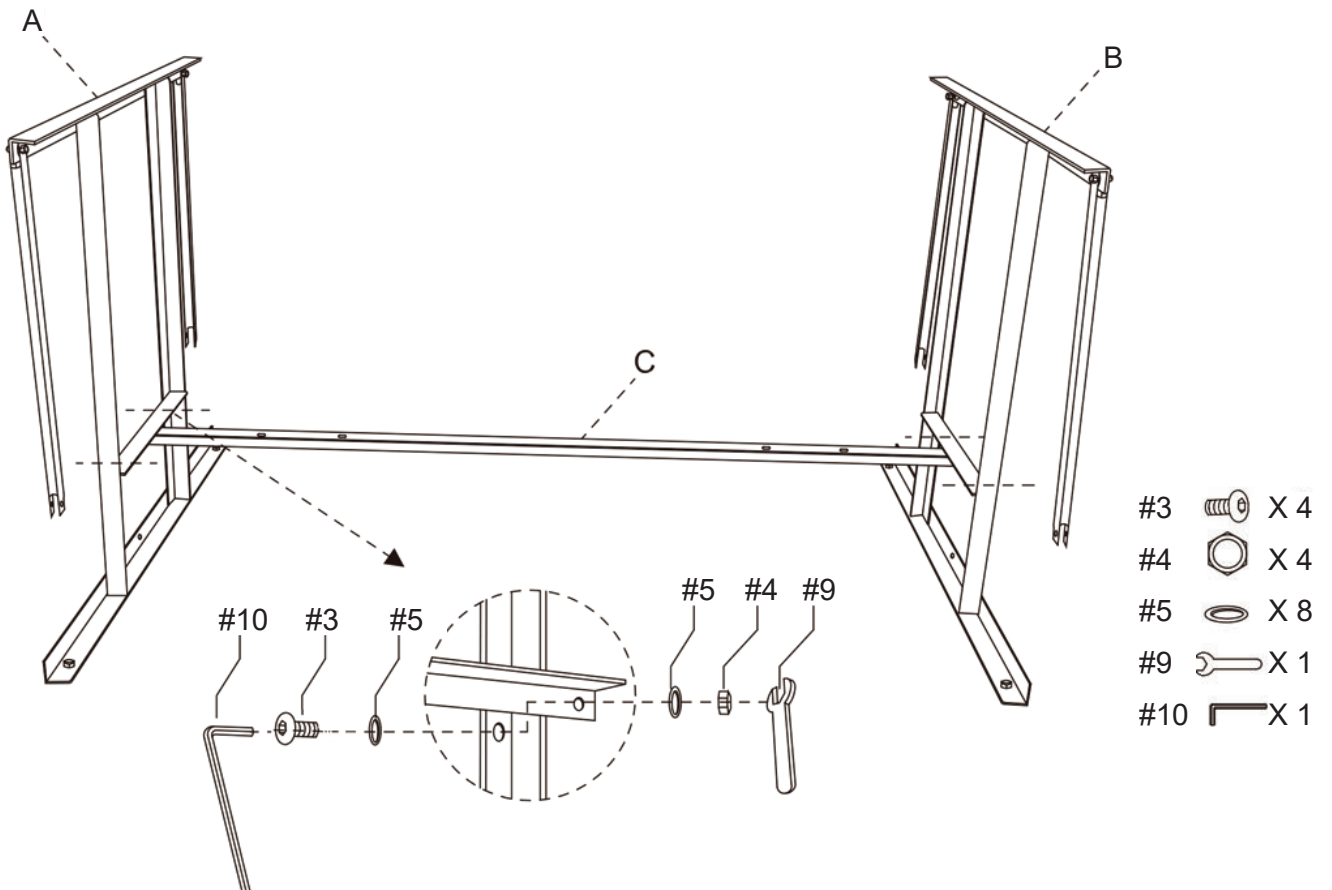

Step 3. Attach supports (part D) to legs (parts A B) and leg support (part C) using short bolts (part #3), metal washers (part #5), self-locking nuts (part #4), wrench (part #9) and allen wrench (part #10)

NOTE: Please do not fully tighten bolts until unit is fully assembled.

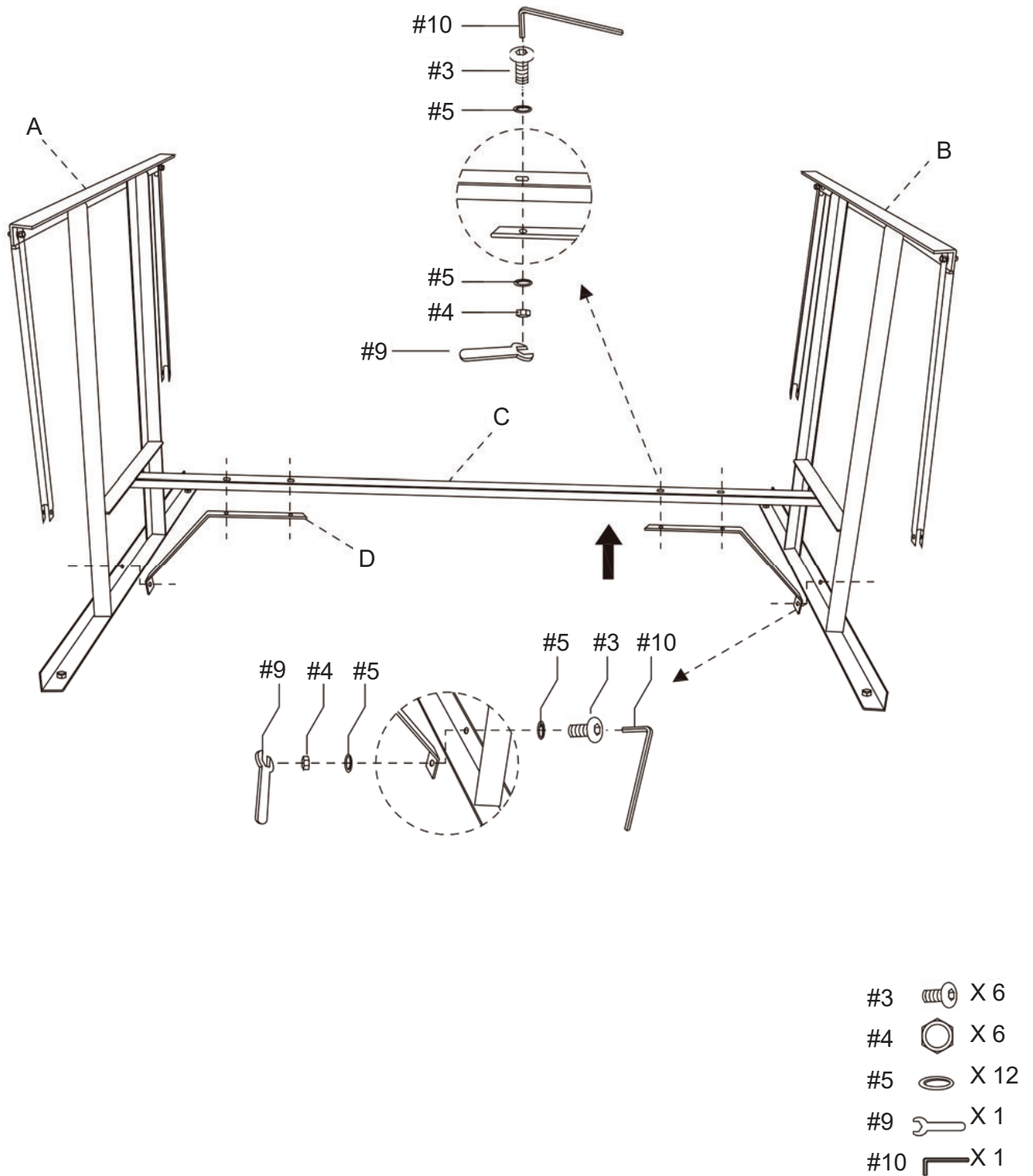

Step 4. Attach back panel (part H) to seat panel (part I) using medium bolts (part #2), short bolts (part #3), metal washers (part #5), self-locking nuts (part #4), wrench (part #9) and allen wrench (part #10).

NOTE: Please do not fully tighten bolts until unit is fully assembled.

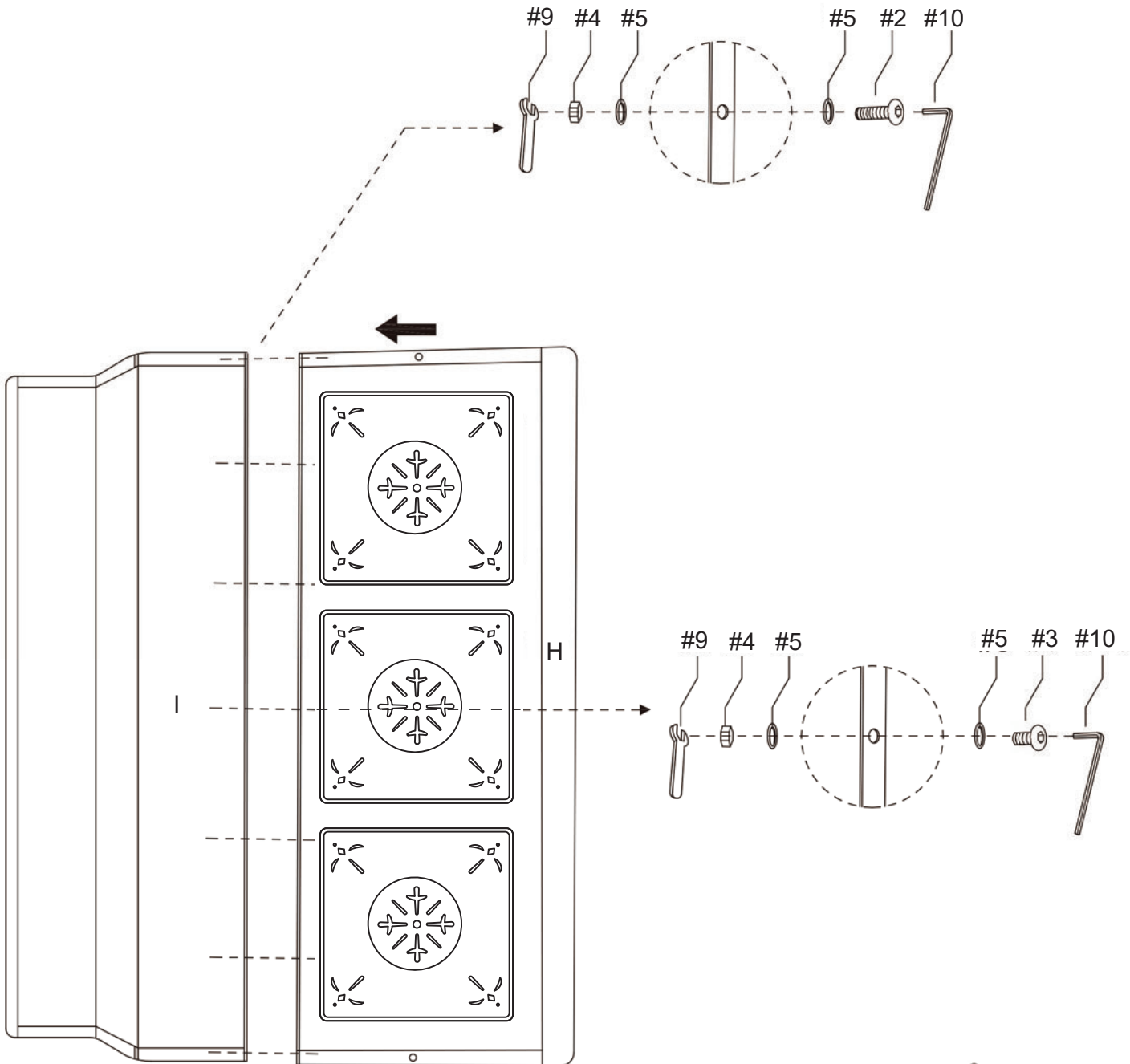

- #2  X 2
- #3  X 5
- #4  X 7
- #5  X 14
- #9  X 1
- #10  X 1

Step 5. Install long bolts (part #1), metal washers (part #5), connecting screws (part #8) and self-locking nuts (part #4) to back panel (part H) using wrench (part #9) and allen wrench (part #10). See Figure 1. Ensure connecting screws (part #8) are on the back of back panel (part H) and sticking out. See Figure 2. Next, connect arms (parts F & G) to assembled unit (parts H & I) using installed connecting screws (part #8), short bolts (part #3), metal washers (part #5), self-locking nuts (part #4), wrench (part #9) and allen wrench (part #10). Ensure assembled unit (parts H & I) is tilted at an angle to line up properly with arms (parts F & G).

NOTE: Please do not fully tighten bolts until unit is fully assembled.

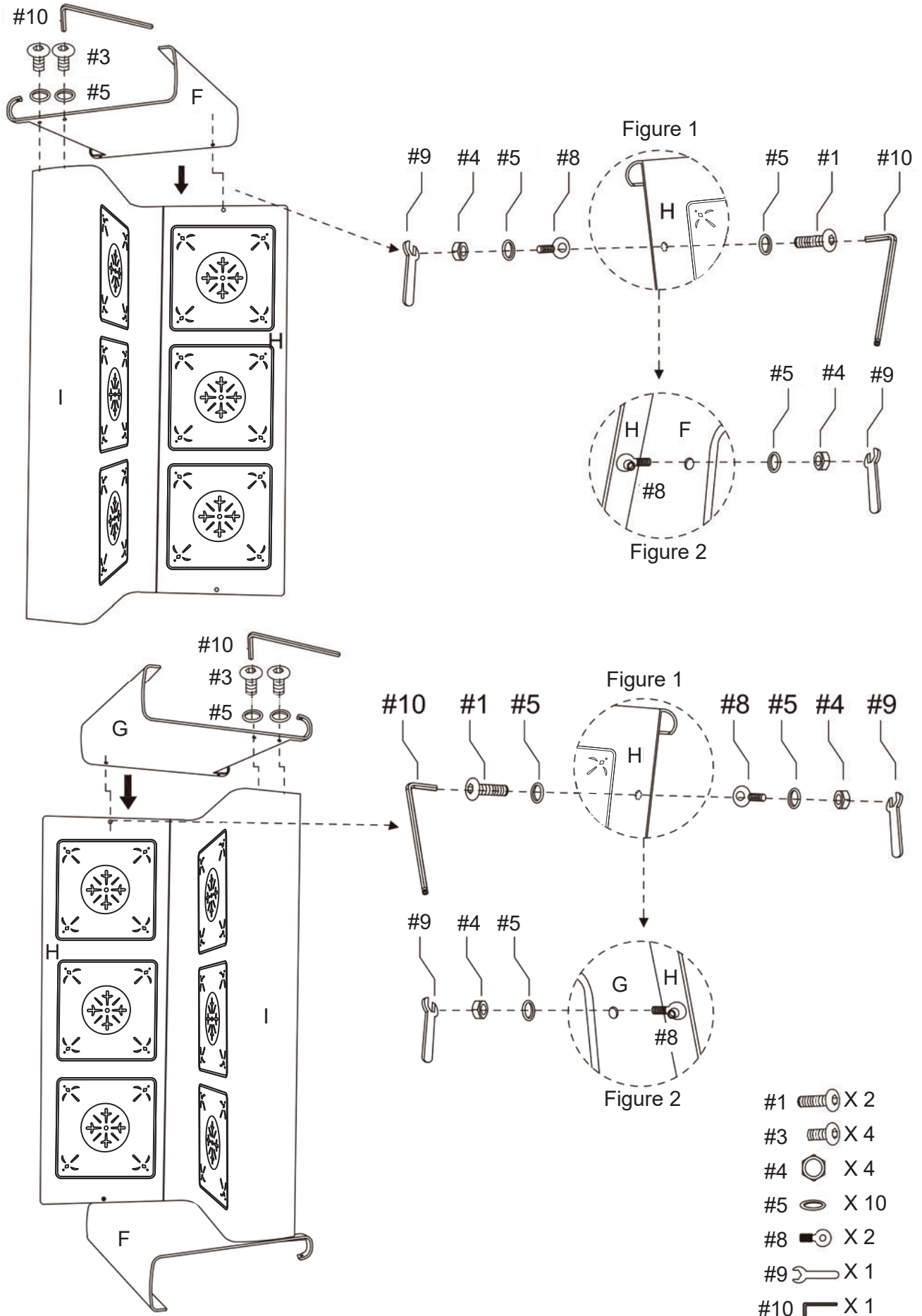

Step 6. Using at least two people, carefully lift assembled unit (parts F, G, H & I) and place inside assembled unit (parts A, B, C & D).

Attach hooks on arms (parts F & G) to swing arms on legs (parts A & B) using long bolts (part #1), metal washers (part #5), plastic washers (part #6), self-locking nuts (part #4), wrench (part #9) and allen wrench (part #10).

NOTE: Please fully tighten all bolts at this time.

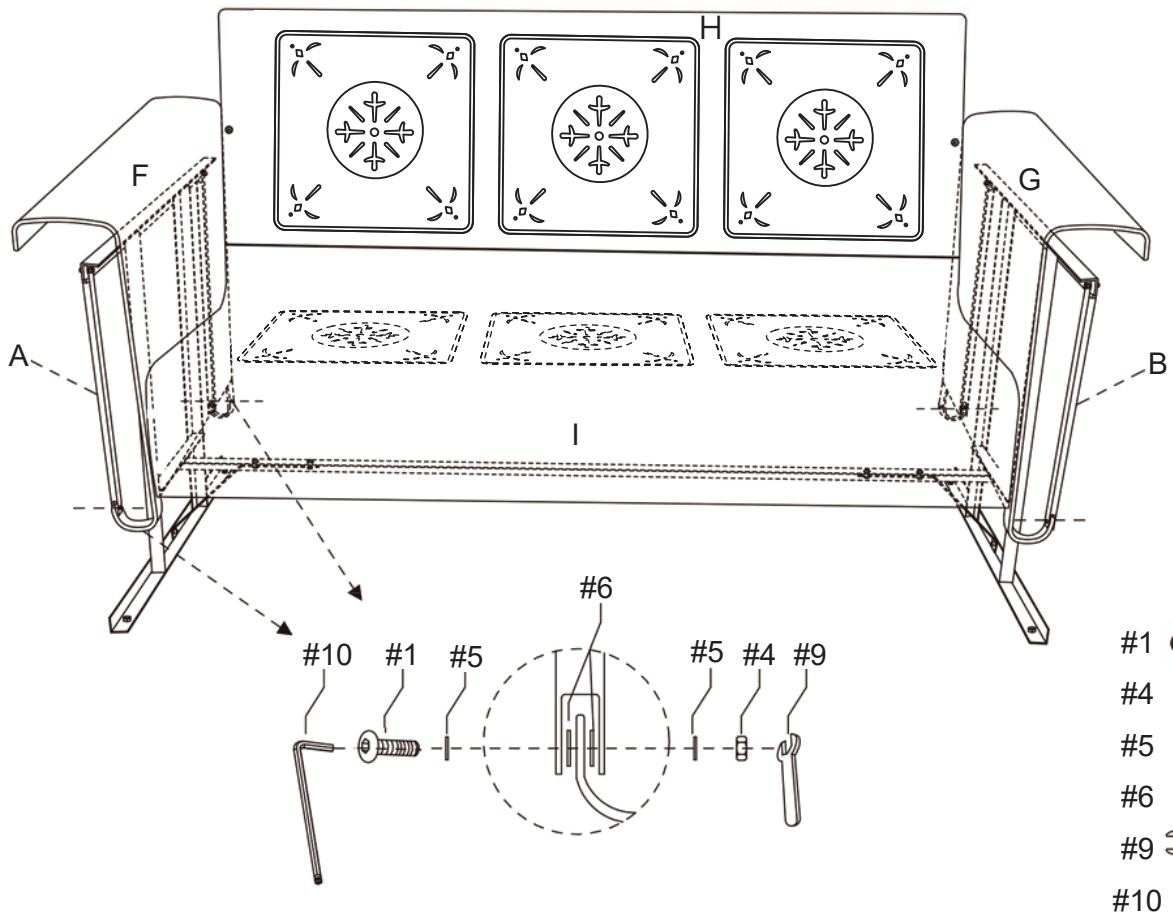
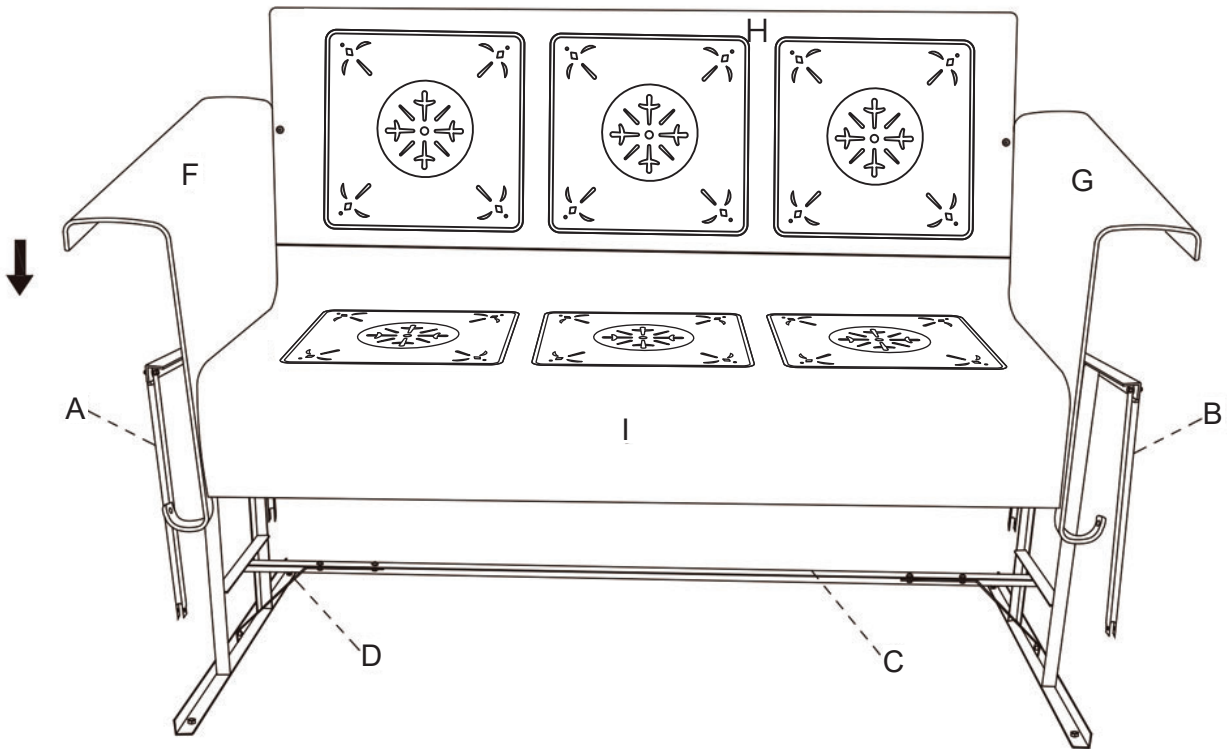

Step 7. Attach connecting wire (part E) to arms (parts F G) using metal washers (part #5), self-locking nuts (part #4) and wrench (part #9).

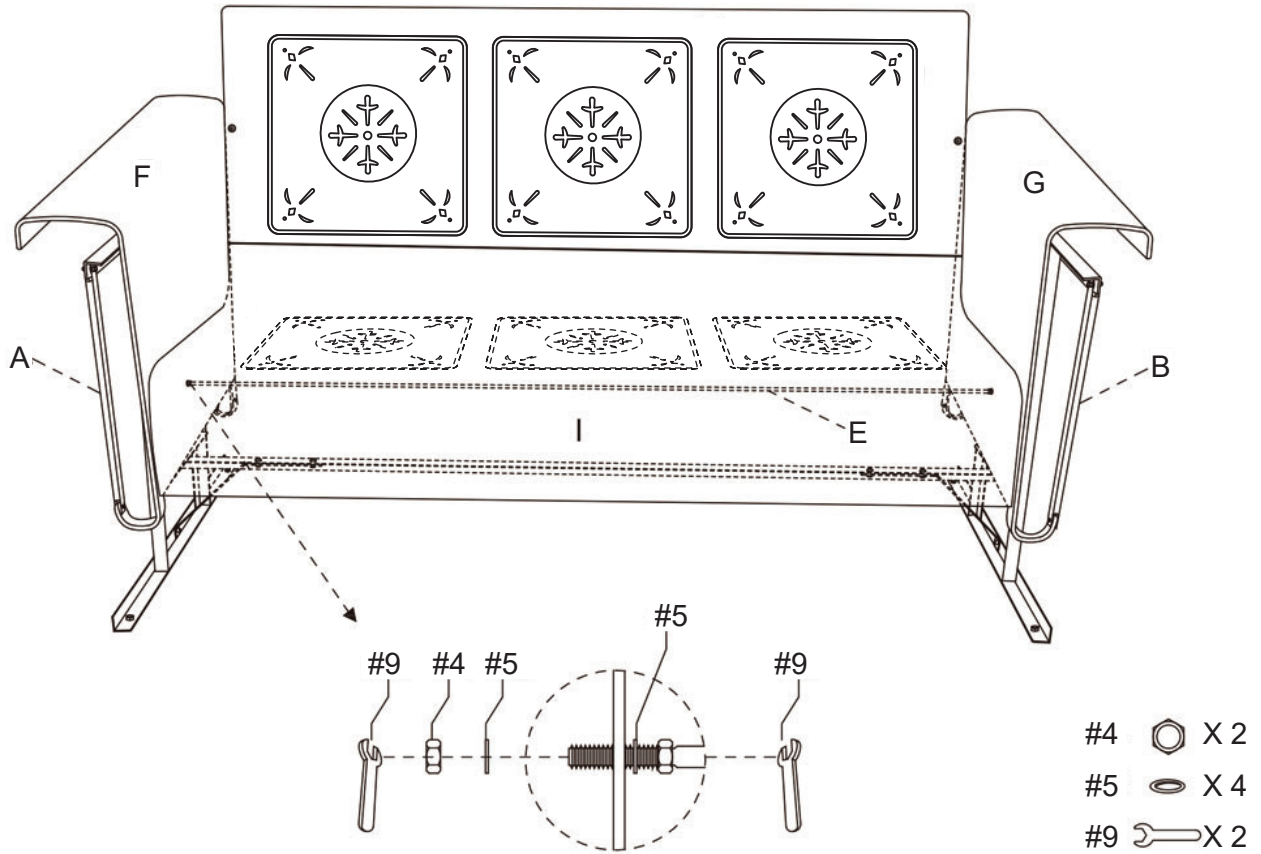

Step 8. Attach connecting wire (part E) to arms (parts F G) using metal washers (part #5), self-locking nuts (part #4) and wrench (part #9).

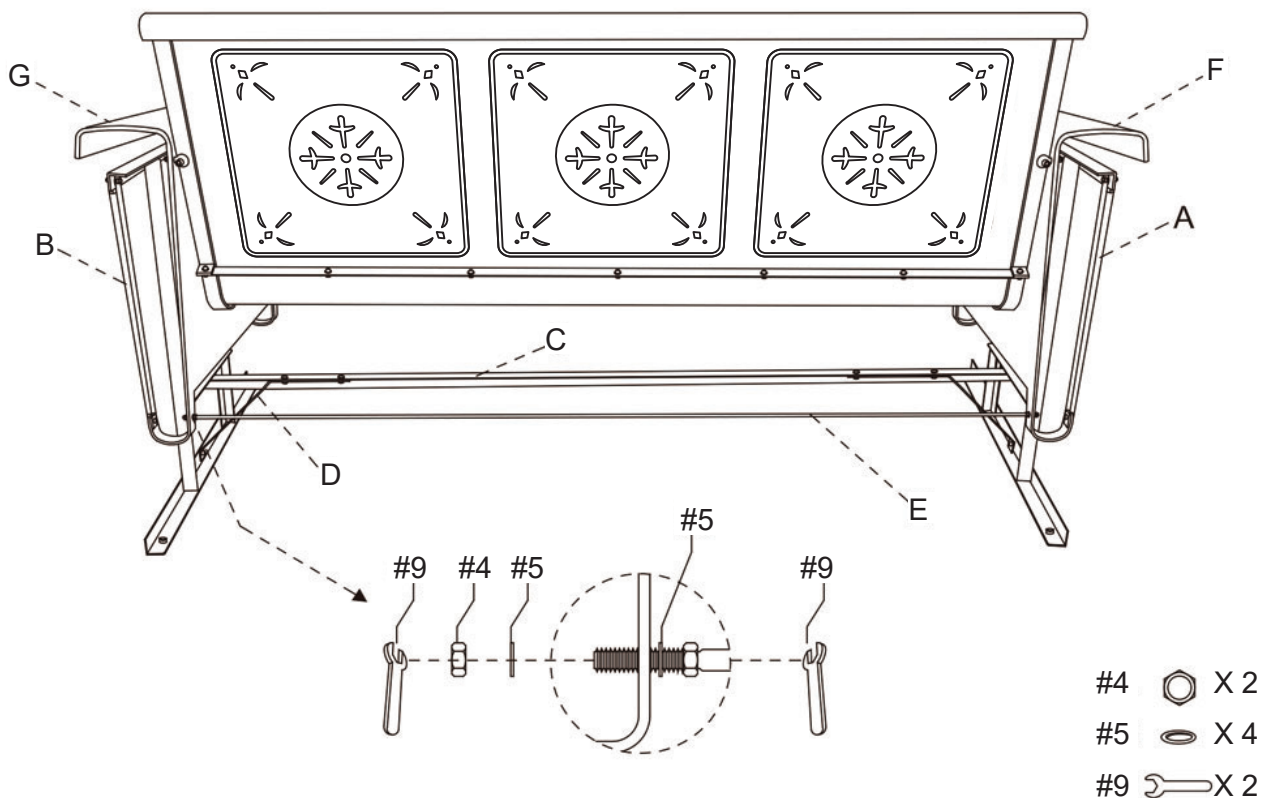

Step 9. **IMPORTANT NOTE:** Please always use at least two people when moving this completed sofa glider, and be careful of the moving parts.

