

HAPPINESS HAPPINESS INSTALLATION



CAUTION

Parts are placed at the bottom of the product.

- If you have any questions with the product, please contact us by:
- **Email: customerservice@zoy-living.com**
(we will reply to you within 24 hours)

Assembly Instructions











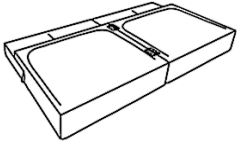

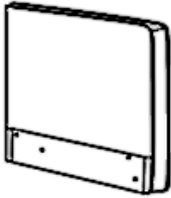
Model: KF3528AF45D

CAUTION

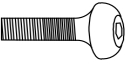
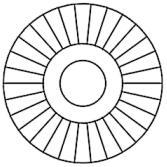
DO NOT use any sharp objects to open plastic wrapped components as this may result damage to product or components .

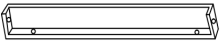
Your sofa comes packaged in **One** boxes. Carefully remove all of components from the packaging and setaside for assembly.

Package Contents

BOX 1 KF3528AF45D				
	A*1	B*1	C*1	D*1 M8*50
				
	E*14	F*1	G*12 M8*40	H*8 M6*25
				
	I*4	J*1	K*1	L*1
				
	M*4	N*2		

1 SOFA ASSEMBLY - BODY SETUP

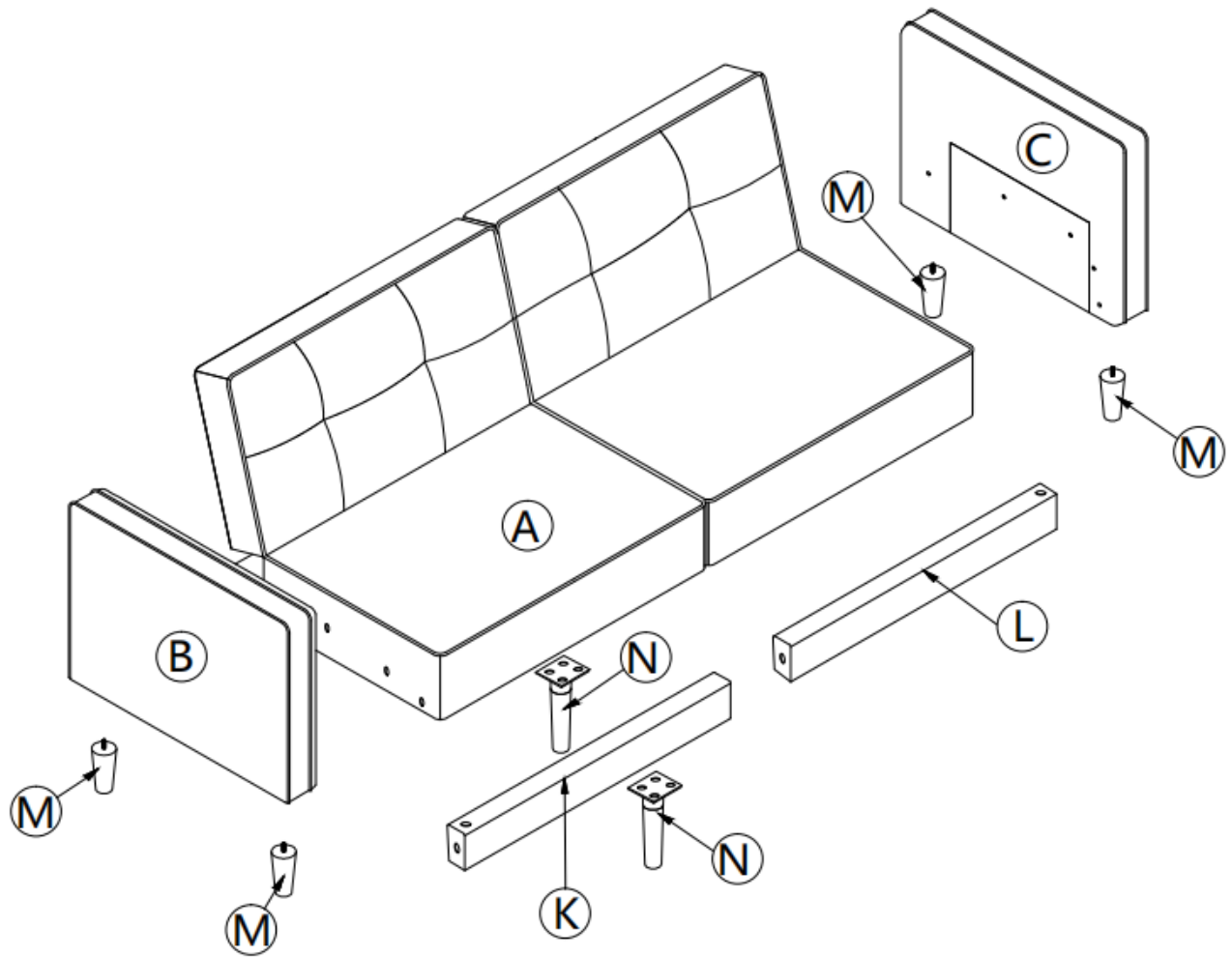

Step1

Take out the **left armrest (B)** and **right armrest (C)** facing the sofa from the **bottom pocket (A)** of the sofa.

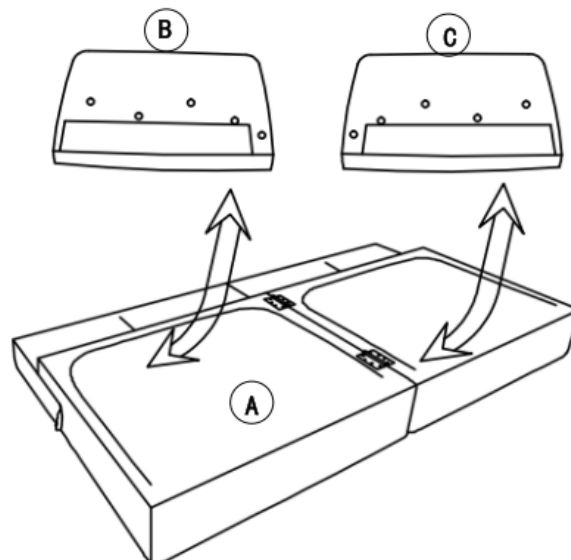

2 SOFA ASSEMBLY - BODY SETUP

Step2

Install the **hardware (E&F&G)** onto the **seat frame (A)** using the **left armrest (B)** and **right armrest (C)** facing the sofa.

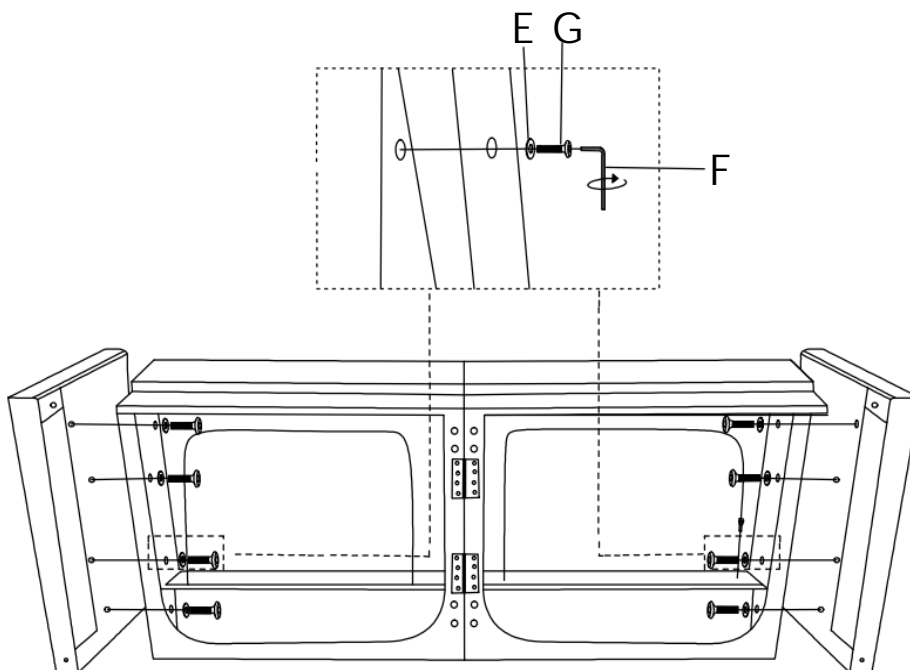

Step3

Install the **hardware (E&G&F)** on the **left side panel (K)** and **right side panel (L)** facing the sofa in front of the **seat frame (A)**.

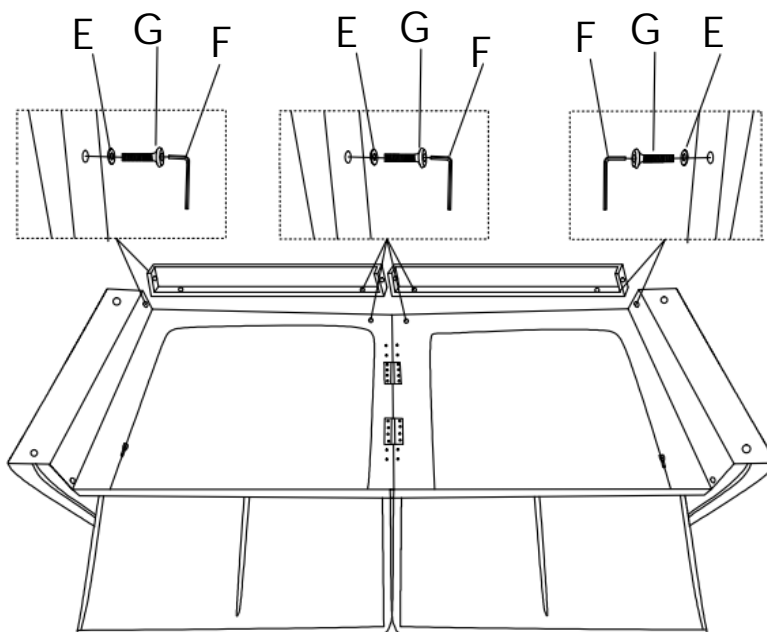

3 SOFA ASSEMBLY - BODY SETUP

Step4

Connect the hardware components (D&E&F&J) to the left panel (K) and right panel (L).

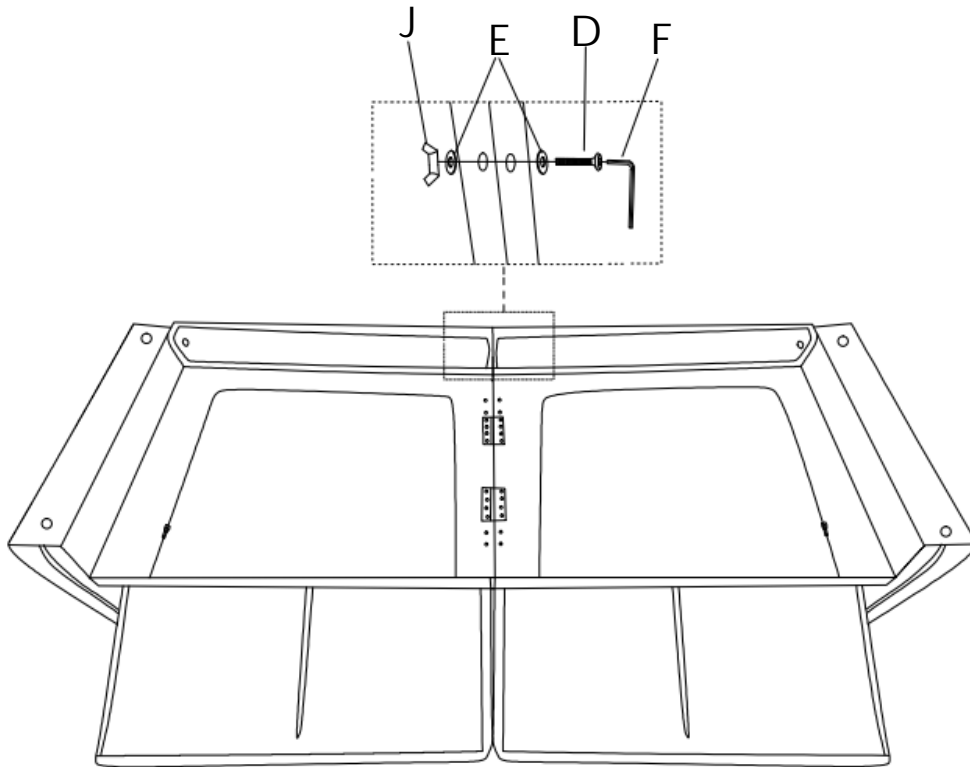

Step5

Install two metal feet (N) onto the seat frame (A) using hardware (F&H). Install the four wooden feet and washers (M&I) onto the armrest.

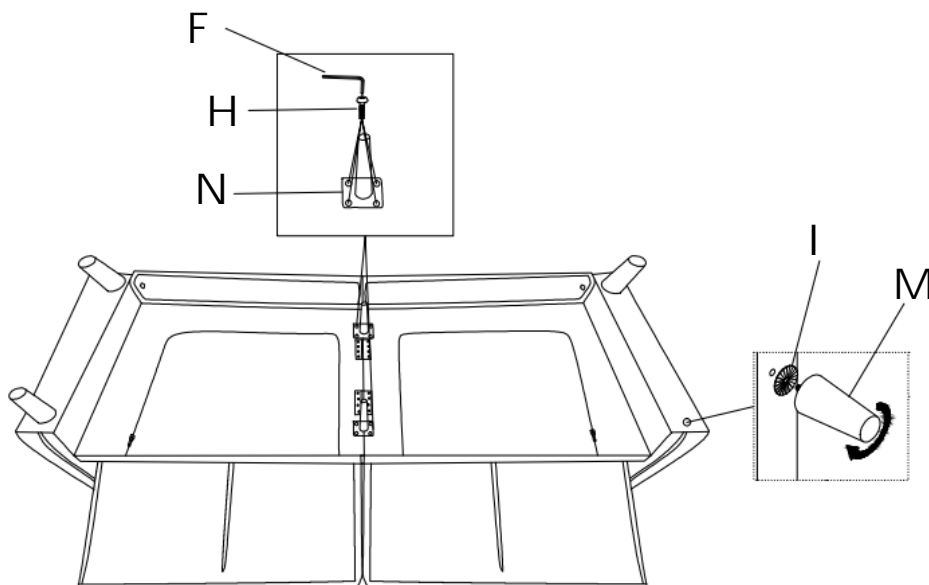

4 SOFA ASSEMBLY - WIRES CONNECT

Installation is complete

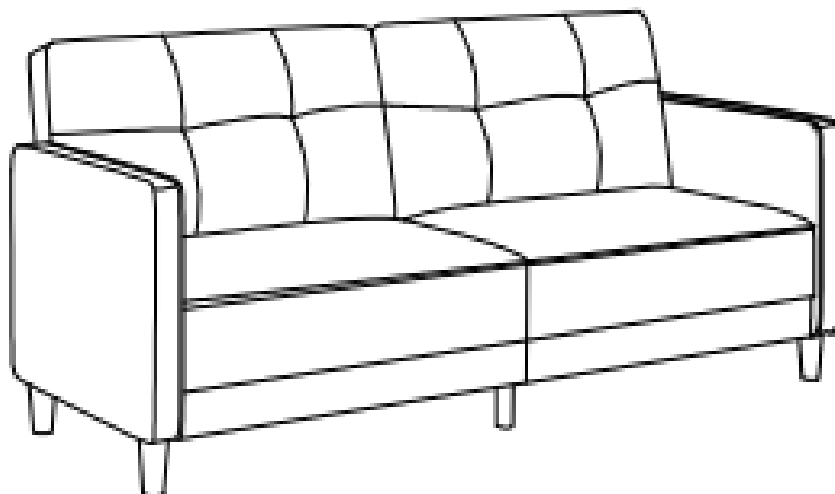

Sofa function display

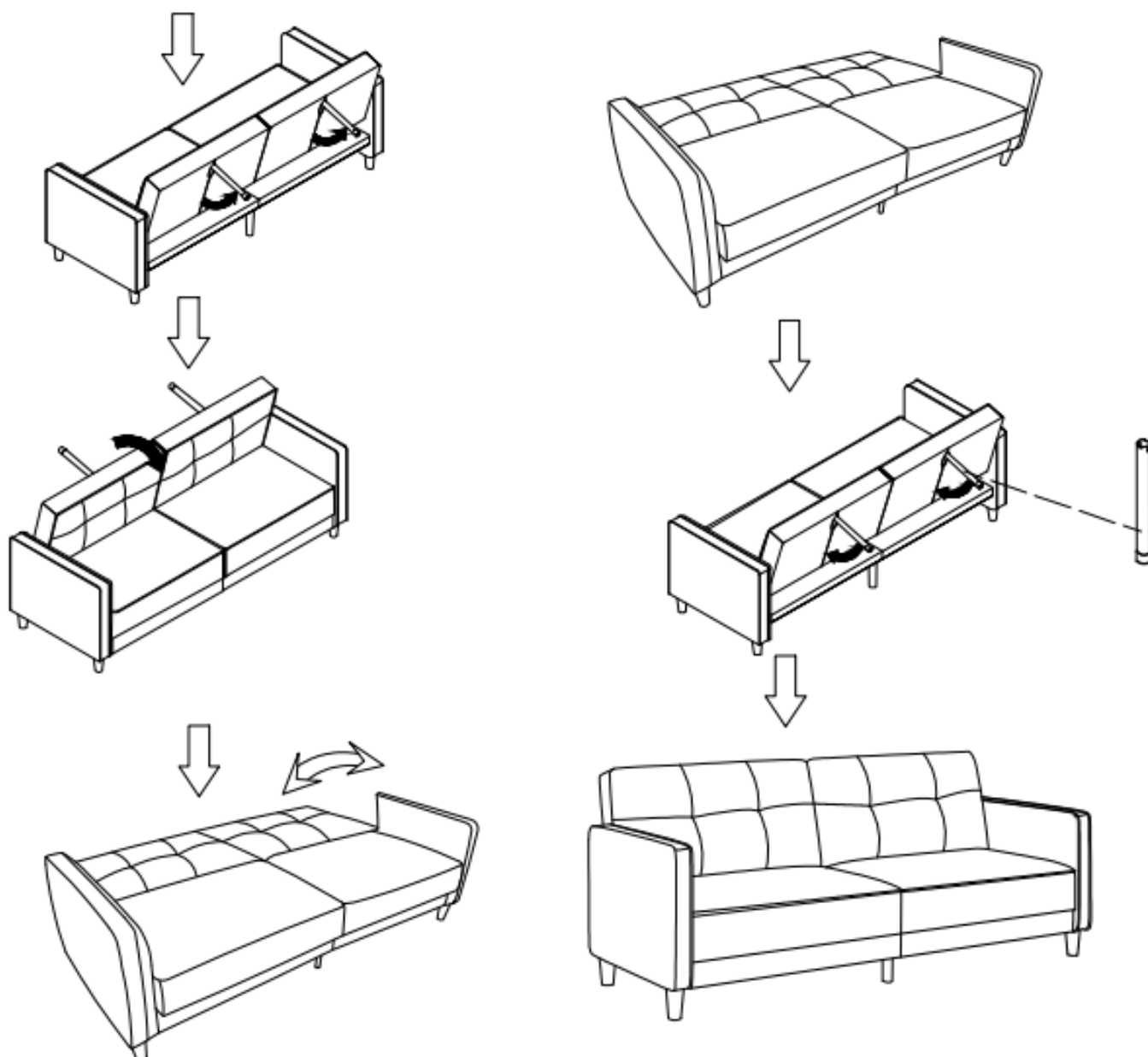

5 SOFA ASSEMBLY - WIRES CONNECT

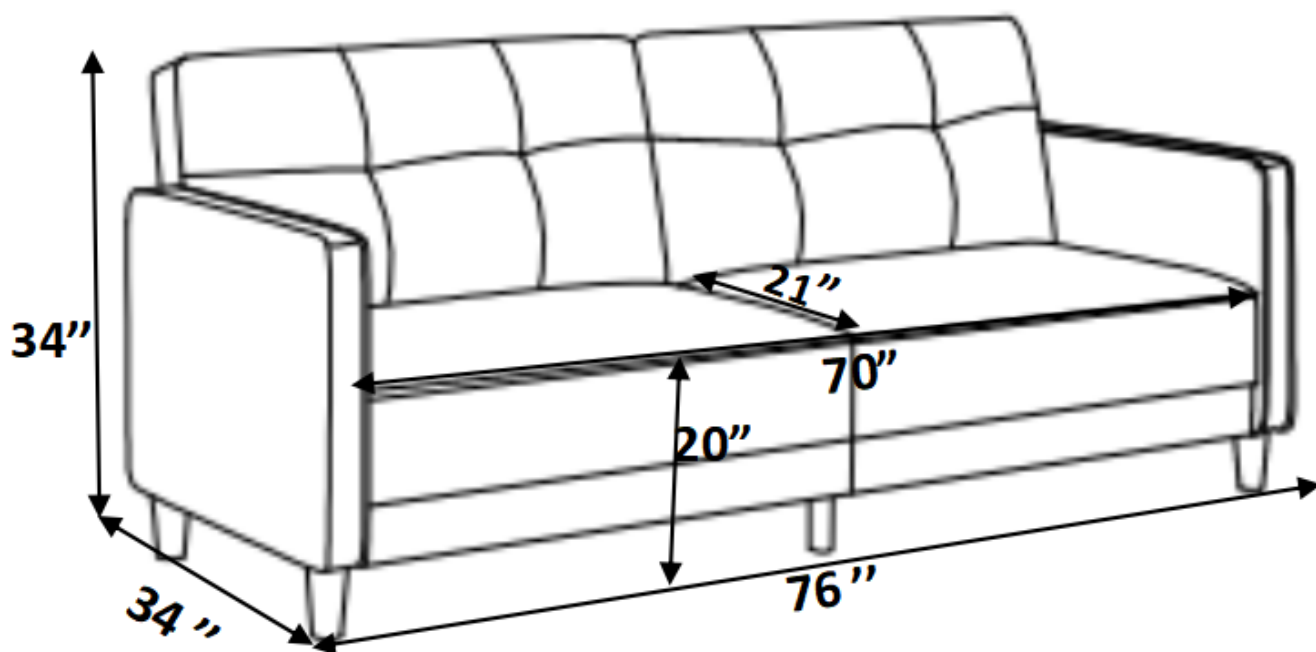

KF3528AF45D

⚠️ WARNINGS

1. Please check if the components of the chair are all included and can be used normally.
2. Assemble all components according to the instruction correctly before you connect the chair to the power.
3. Please DO NOT sit on the armrests or footrest to eliminate the risk of tipping over.
4. If the chair is damaged or doesn't match the website description, please send clear pictures of the product and label of the carton to our service team for further help.
5. If the recliner doesn't work, you may try the following measures for self-checking firstly:
 - a) check if all the cables are connected;
 - b) check if the light of transformer is on.

If the chair still doesn't work, please feed the information back to our customer service in time and we will help you solve the matter as soon as possible.

6. If you have any questions about our products, please contact us by:

Email: customerservice@zoy-living.com (we will respond to your inquiry within 24 hours)

