

# Massage Sofa

## Operating instruction

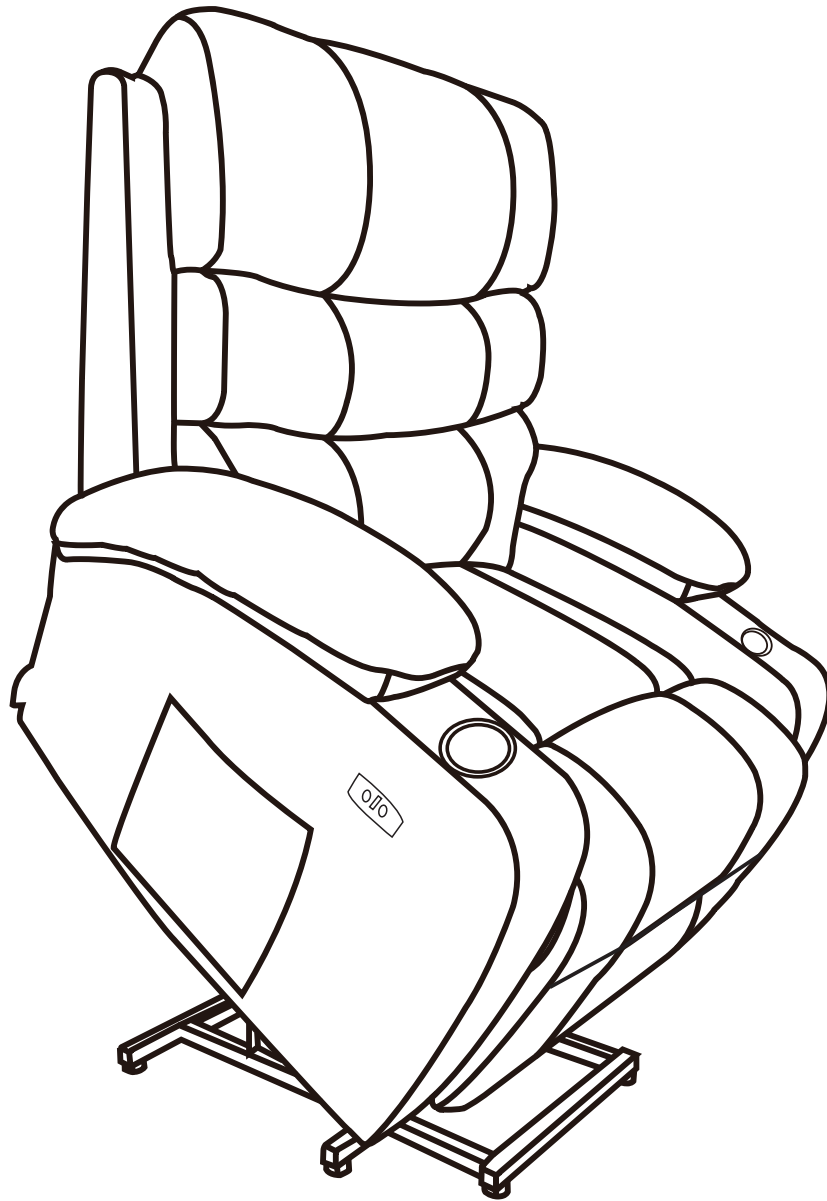

NOTE: This sofa is shipped in 2 box . All accessories included. If you have any questions after receiving the recliner. Please contact us in time and provide pictures. We will try our best to help you solve it.

# **ATTENTION**



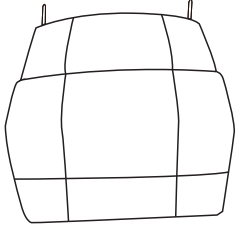
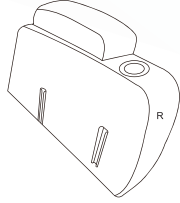
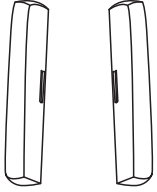

**Enjoyable time on recliner is coming after 15 minutes of installation!**

- 1. Please check the manual carefully and make sure you have received all the parts.**
- 2. If there is any missing parts, please let us know the letter of the parts you need.**
- 3. If there is any damage parts, please send clear photos to us, we will check and offer you best solution soon.**

## BOX A

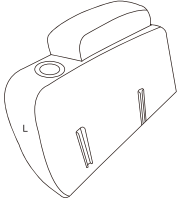
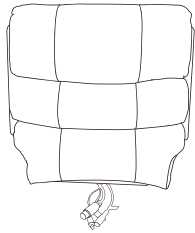
Part	Description	Qty	Part	Description	Qty
A		1 pc	B		1 pc
I		2 pcs			

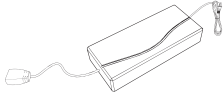
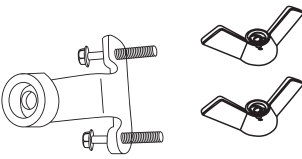
## BOX B

Part	Description	Qty	Part	Description	Qty
J		1 pc	C		1 pc
D	 Power Cord	1 pc	E	 Remote control	1 pc
F	 Power Source	1 pc	G	 Anti-fall Bracket	2 pcs
H	 Backup Foot	4 pcs			

# Step 1

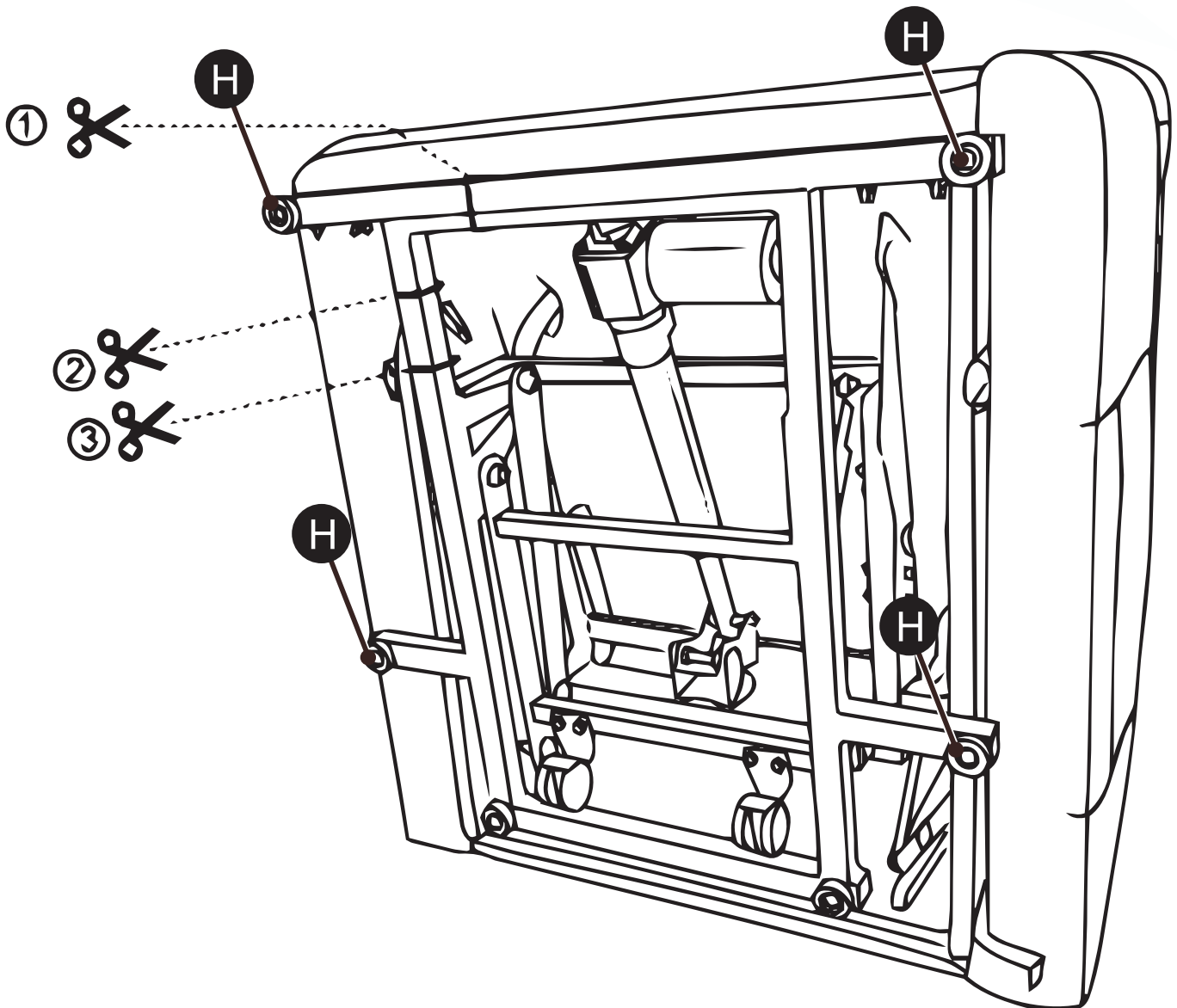

Accessories:

Part H \* 4

Turn over the base part, cut off #1&#2&#3 cable ties.

## Step 2

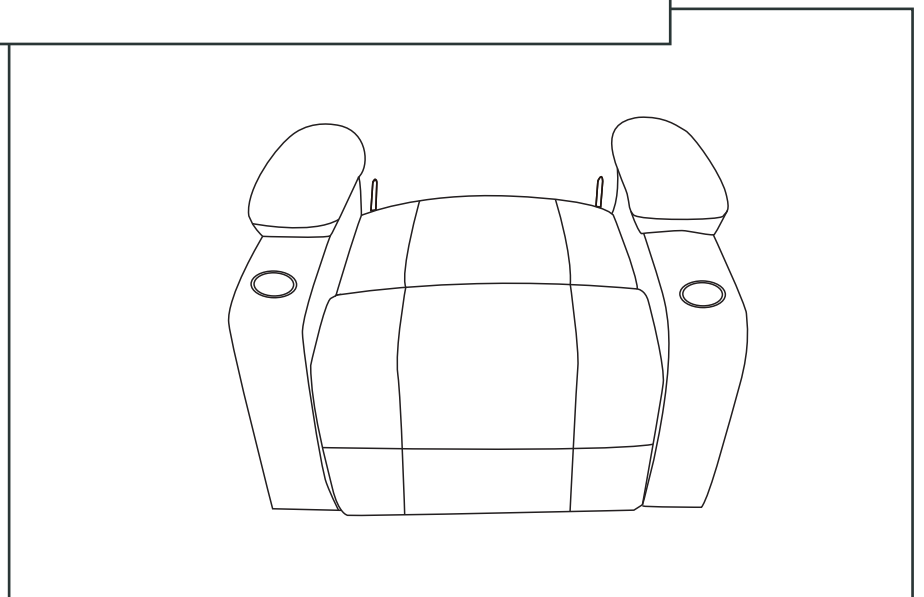
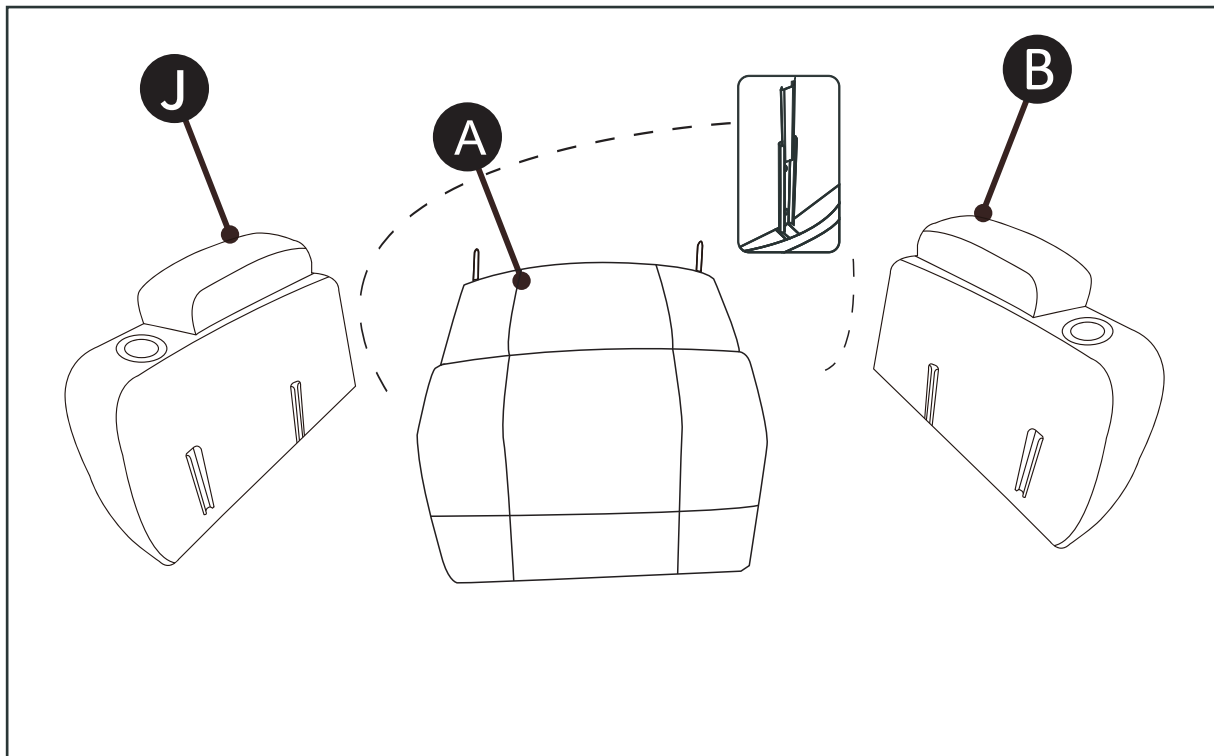

Accessories:

Part A \* 1 Part B \* 1 Part J \* 1

Assemble left and right armrests into the slots on the chair base.

## Step 3

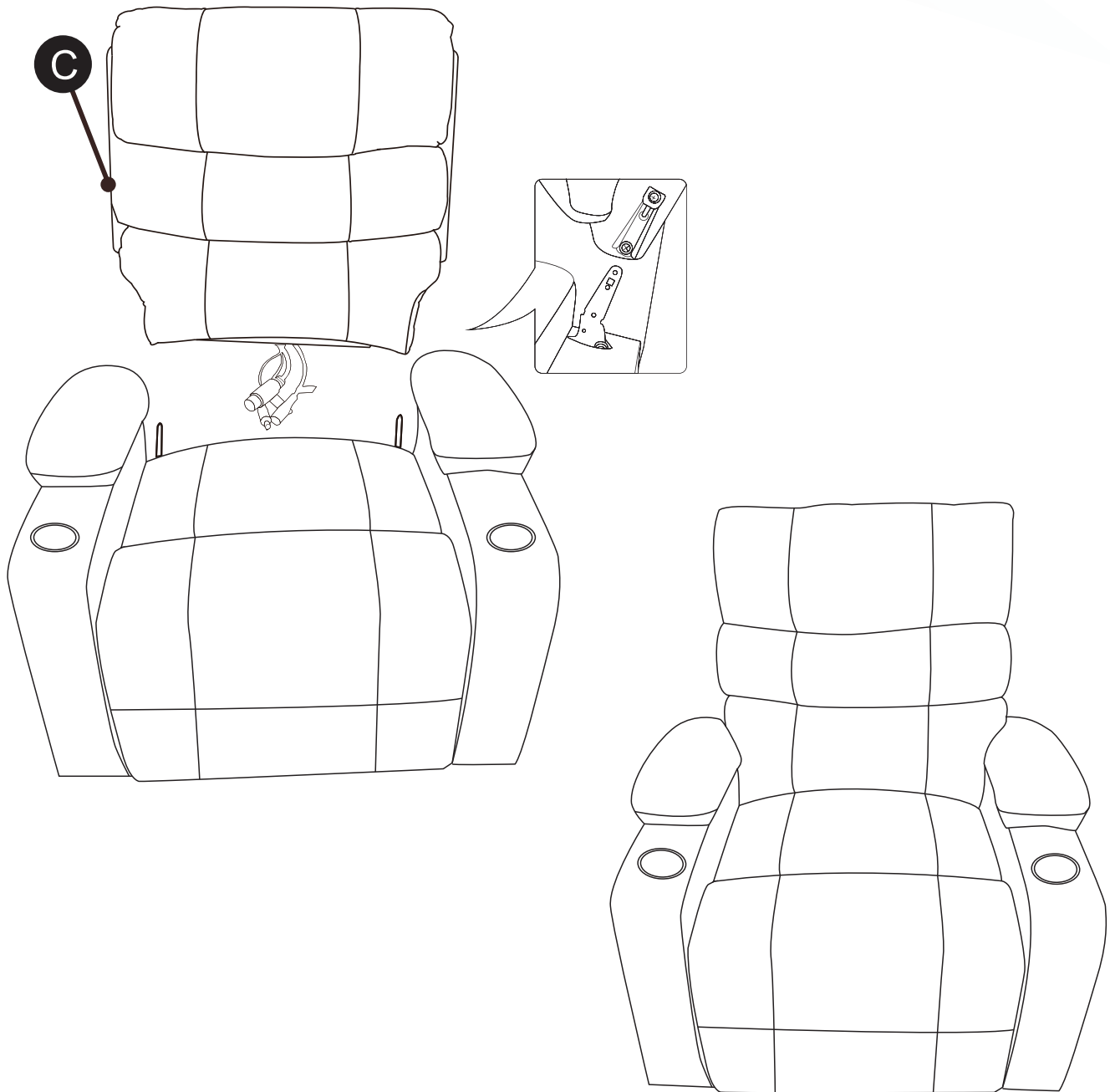

Accessories: Part C \* 1

NOTE: If the armrest or back shakes after assembly, please dismantle it and assemble it again, make sure that all the slots are properly aligned.

## Step 4

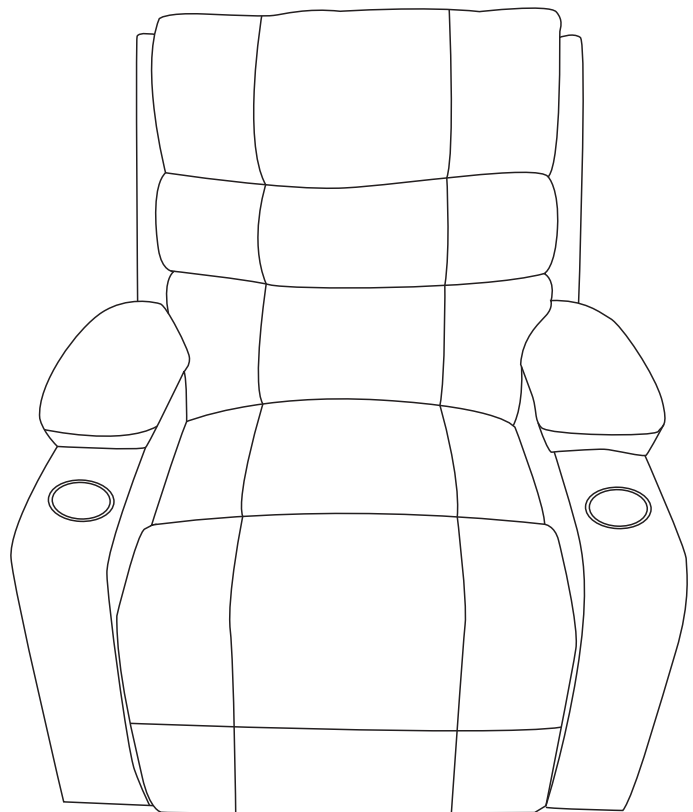
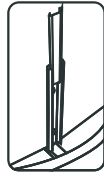
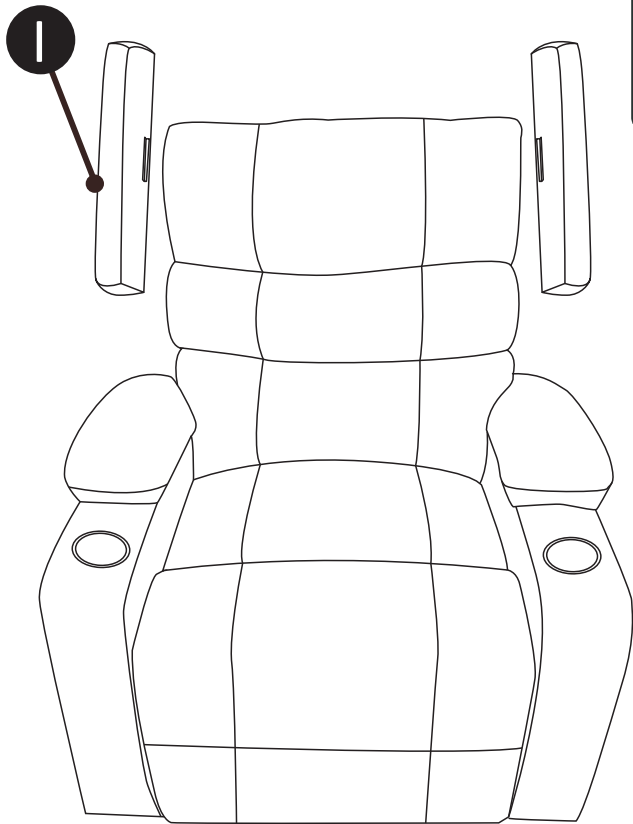

**Accessories:**  
Part I \* 2  
Connect backrest

## Step 5

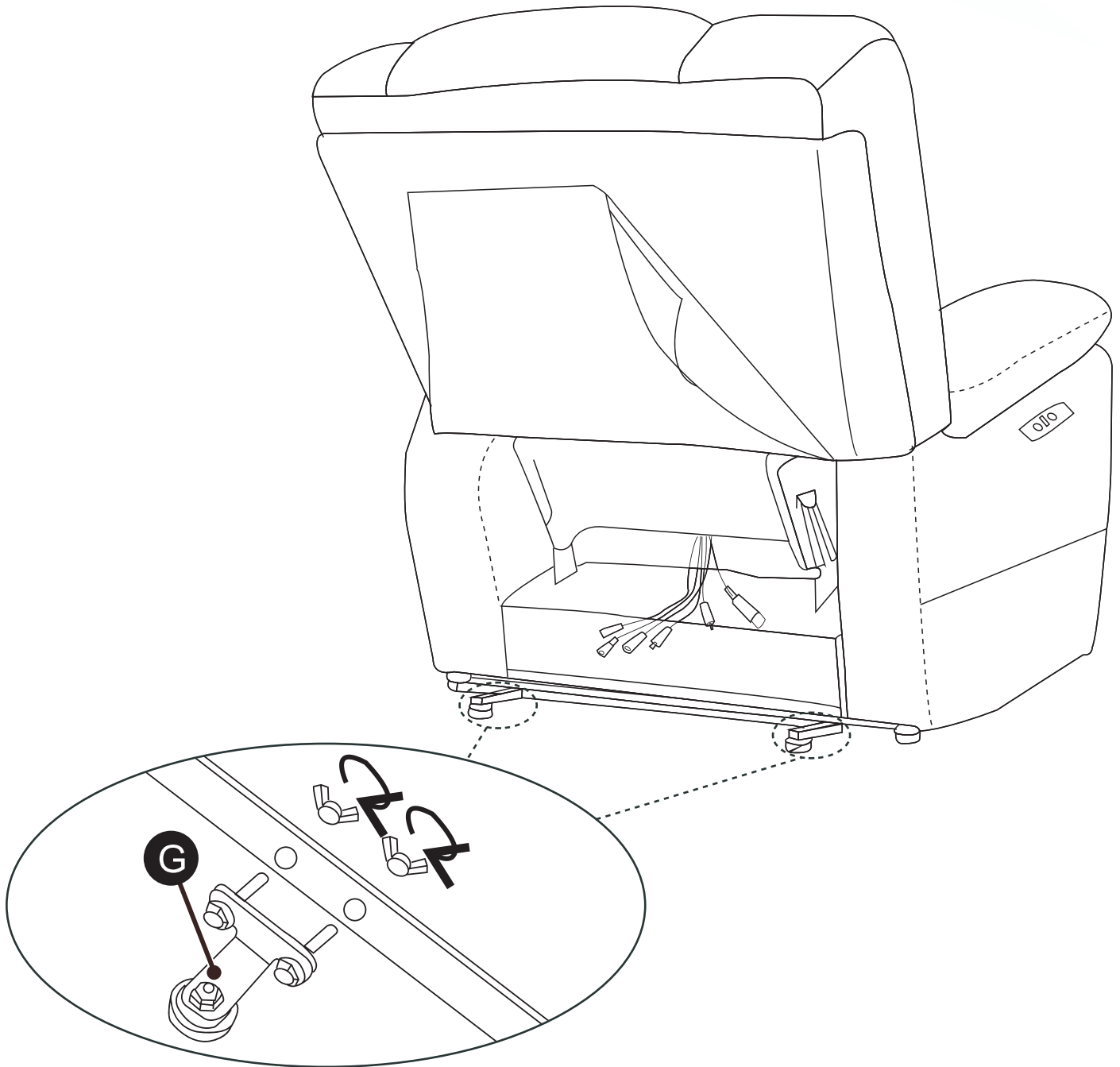

Accessories:

Part G \* 2

Attach brackets to the base with wing nuts.

## Step 6

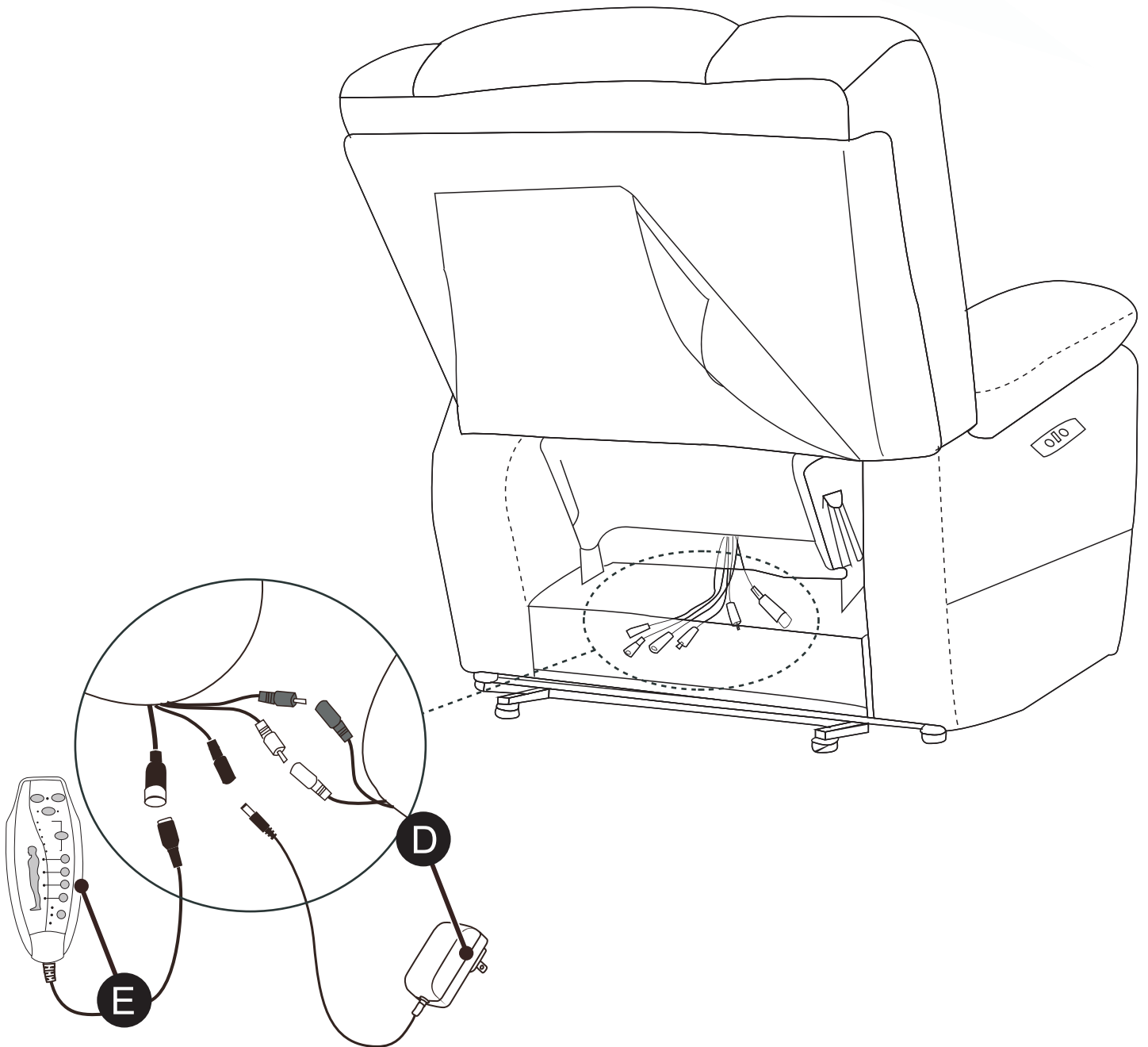

Accessories:

Part D \* 1, Part E \* 1

Connect the wires which has the same color.

## Step 7

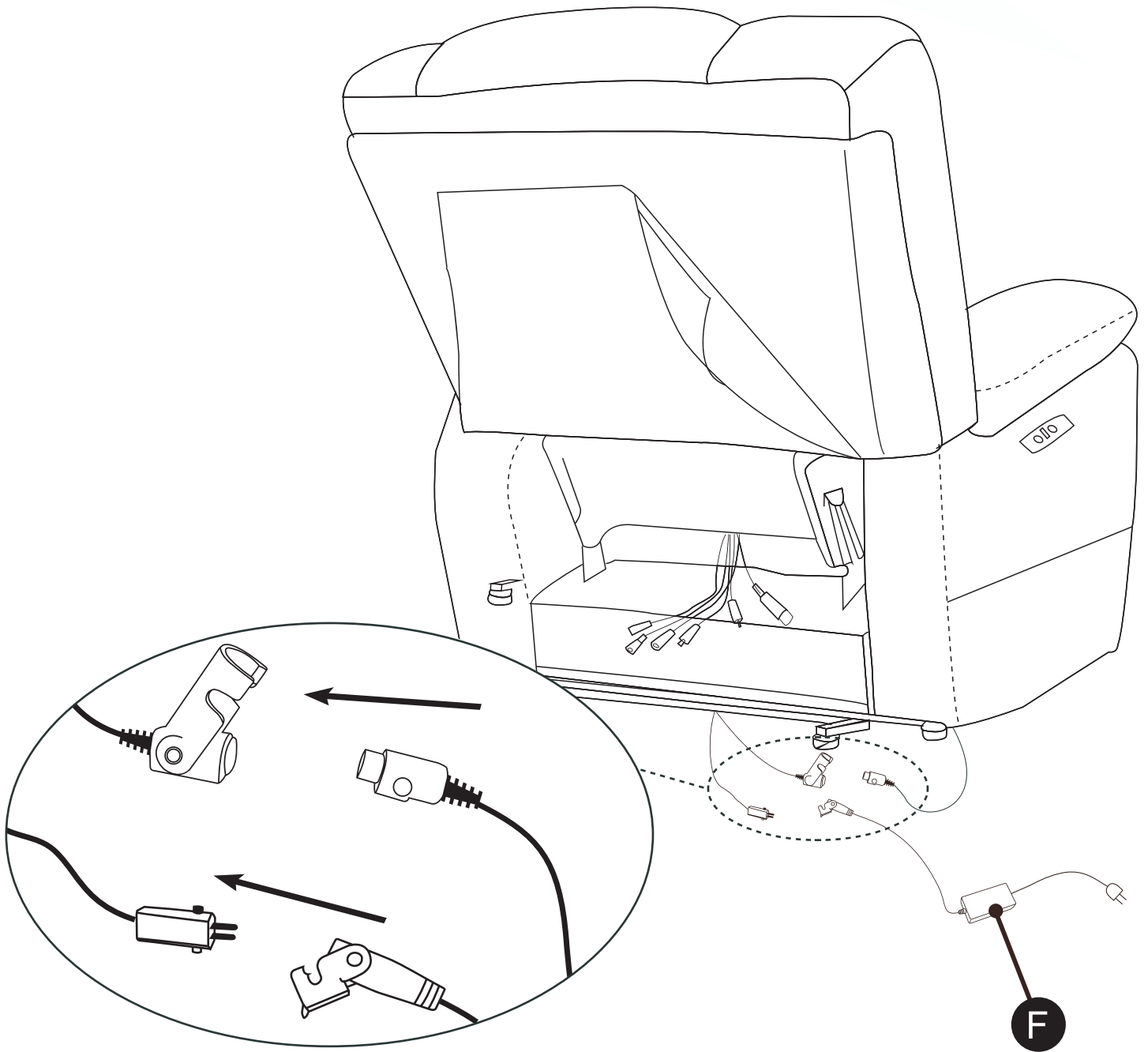

Accessories:

Part F \* 1

NOTE: Plug power cord and power source into outlet, then you can use all function.

# Functional instruction

## How to use remote control?

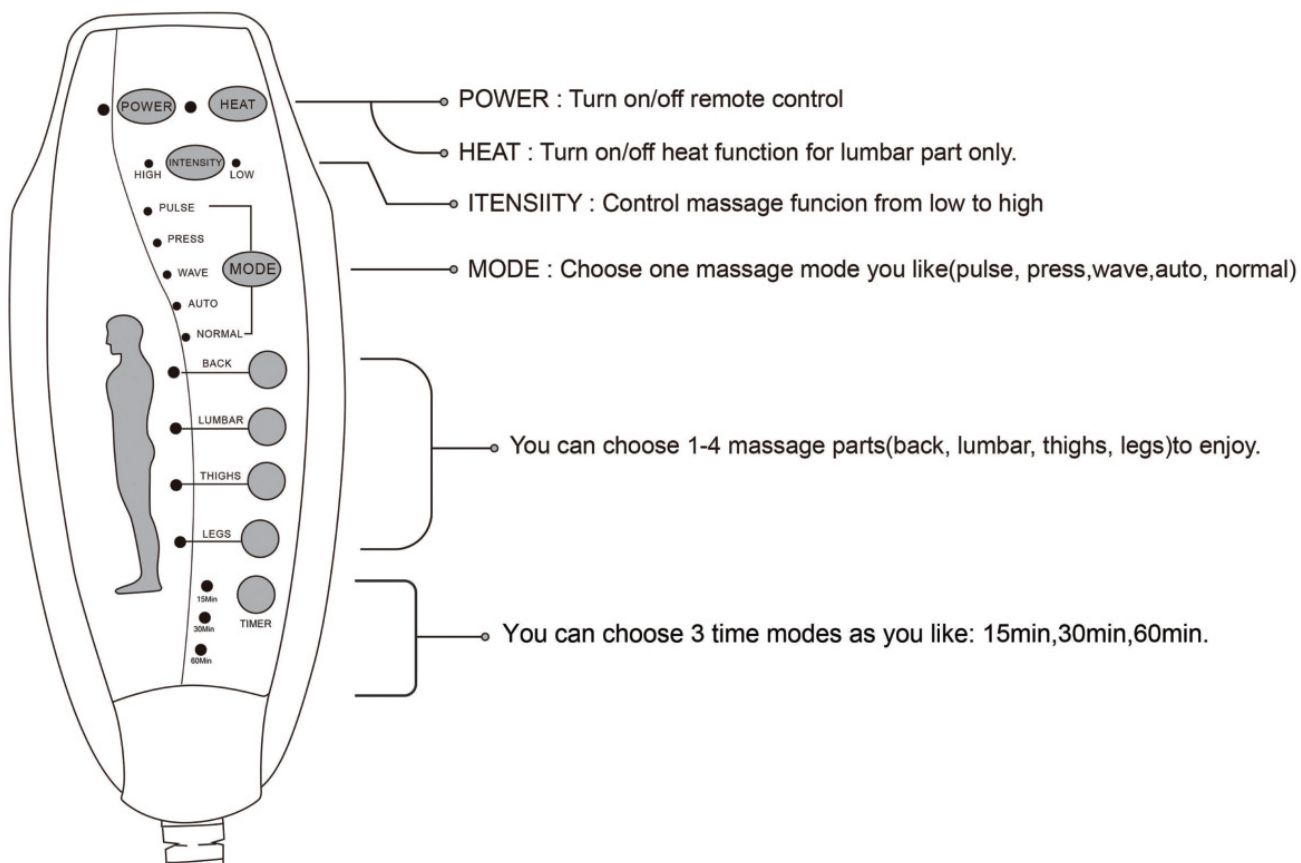

# Warning

Do not sit/kick/stand on the footrest when the chair is on reclining position

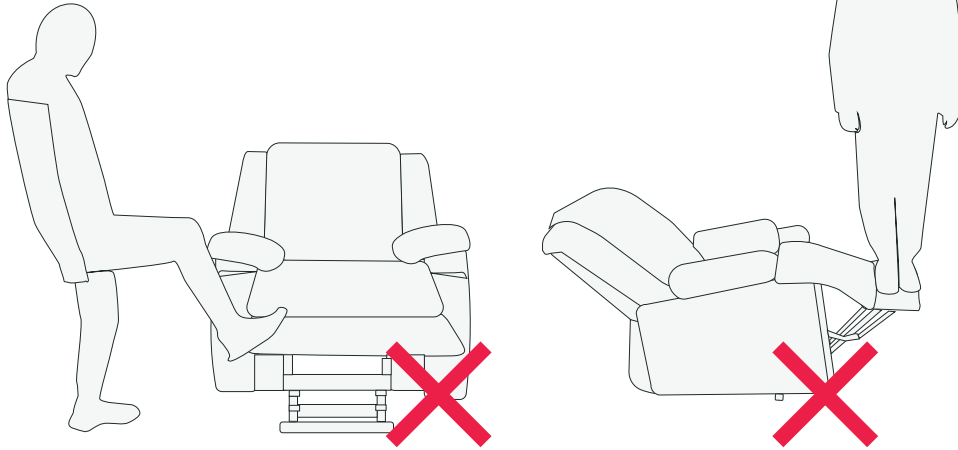

Do not stand up when the chair is on reclining position

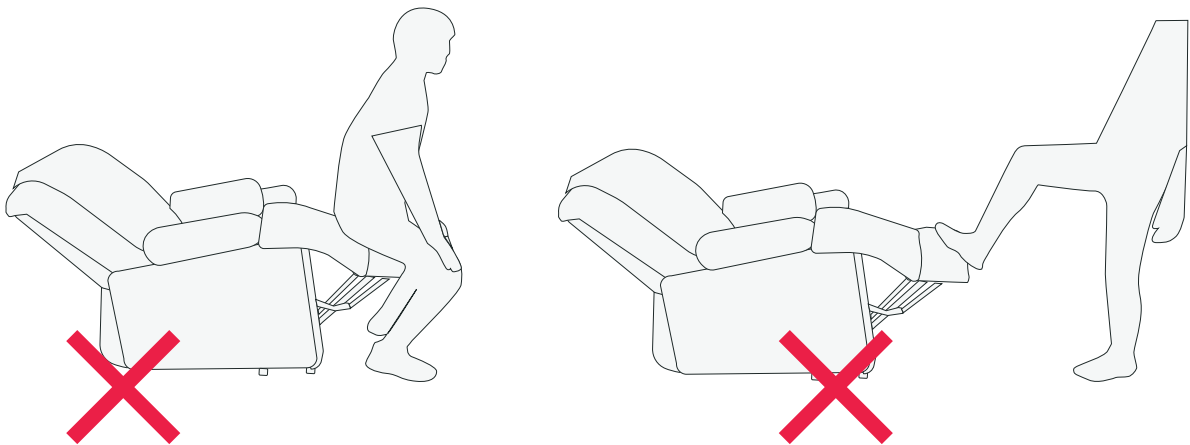

Leave enough space between chair back and wall before reclining

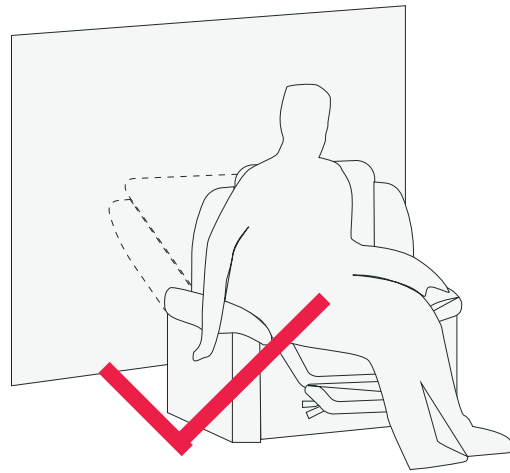

Do not sit on or  
press armrest

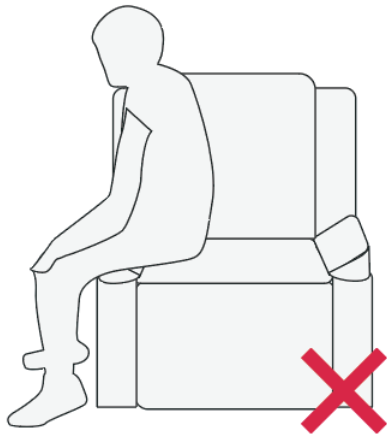

Do not press armrest  
after recline



Unplug all powder source  
from socket, then unplug wires  
connection before move chair

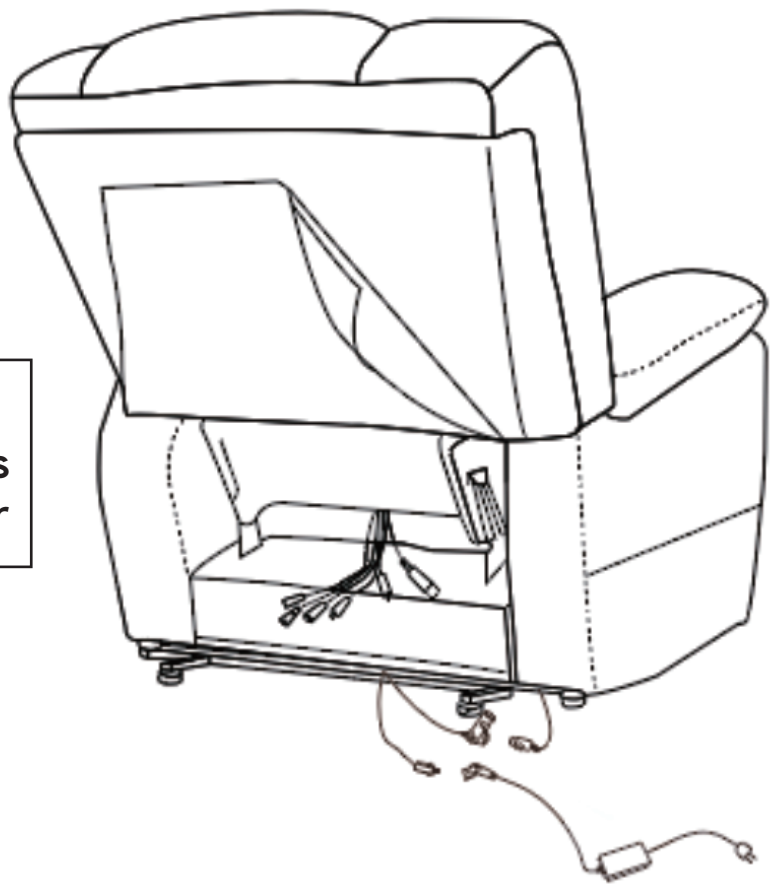

Do not smoke or play with fire

# WARRANTY

So glad you have completed the assembly and can enjoy it. If you are satisfied with our products, thank you for showing your favored massage recliner to your around.

The quality of our furnitures has been strictly controlled. Each stage of the product upgrading has condensed the efforts of employees in various departments. We strive to minimize the probability of failure of new products and insist on providing customers with worthless after-sales service.

# AFTER-SALE POLICY

## **For return reason:**

Wrong purchase, bought by mistake, no longer needed, doesn't meet expectation, a size smaller than expectation, customer need to cover the return shipping fee.

## **For cancel order:**

Customer needs to pay for shipping fee and carrier handle fee if the item has been shipped out.

## **For change address:**

Customer needs to pay for extra shipping fee and carrier handle fee if the item has been shipped out.

Customer Service: Any problem with the product or shipping issue, please feel free to contact us, we will try our best to serve and help.

# Answers & Questions

## FAQ

### 1. **Q: Missing parts**

A: Please check if you have already received two boxes. If so, kindly send messages to let us know missing part name regarding this instruction, we will send replacement for you asap.

### 2. **Q: Some parts damaged when arrived**

A: Please send damaged parts photos to us as message attachment, we will check and offer good solution soon.

### 3. **Q: The lift and reclining function does not work**

A: Please check if all wires connect correctly, the power source is defective if indicator does not light on, or else, chair base is defective, kindly send messages to describe the problem then we will send replacement chair base for you.

### 4. **Q: The chair is stuck on lifting or reclining position, and there is no response when you press the lifting or reclining button.**

A: Please kindly check if the power source (F) and control panel are connected well. Sometimes the power source(F) may fall off from the wire at armrest. If they connected well, then check the left motor having some anomaly, like some noise comes out when you press the lift and recline button. If you can make sure the motor is defective, please contact us for replace motor or base of chair.

### 5. **Q: The vibration massage functions is not working.**

A: Please check first if all wires at the back of recliner chair are connected correctly. The power cord also been plug into the wall outlet. Then please check the lights on when you press "POWER"button on the remote. If no, the remote is defective and you can contact us for new one to replace.

### 6. **Q: The Heat function not work or can't feel.**

A: Please check all wires connection as same as question 5 first. If the remote also works well, you will need wait for 5-10 mins after you press the "HEAT"button. The heating is only works at lumbar position and the heat temperature isn't very hot.