

ASSEMBLY INSTRUCTIONS



TOOLS REQUIRED:

Allen Wrench (Provided, Part H)
 Spanner (Provided, Part G)
 Phillips Screw Driver (Not Provided)

BEFORE YOU START:

1. Check the hardware against the hardware list to make sure all items are present.
2. Assemble your furniture on a soft, flat surface to avoid scratching the finish.
3. **CAUTION:** Do not over tighten screws, nuts or bolts during assembly.
4. Your furniture may require occasional tightening.

INSTRUCTIONS:

1. Turn the table upside down on a clean soft surface.
2. Attach the seat frame to back side using Bolt (B)&(C), Lock Washer (D), Flat Washer (E), and tighten all Bolts with Allen Wrench (H) as shown in Figure 1.
3. Attach one front leg to seat frame using Nut (A), Lock Washer (D), Flat Washer (E), and tighten all Bolts with Spanner (G), as shown in Figure 2
 (Note: Need to follow "R" or "L" the label on the leg and seat frame.)
4. Attach one side stretcher to front leg and back leg using screw(F) as shown in Figure 2
 (Noted: Please note the labels on the side stretcher, "front" label means this side need to assemble with the front leg. "back" label means this side need to assemble with the back leg.)
5. Attach the front stretcher with "U" metal to the front leg using screw (F). as shown in Figure 2
6. Repeat steps 3, 4, & 5 for other front leg as shown in Figure 3
7. Tighten all bolts before turning the barstool upright.

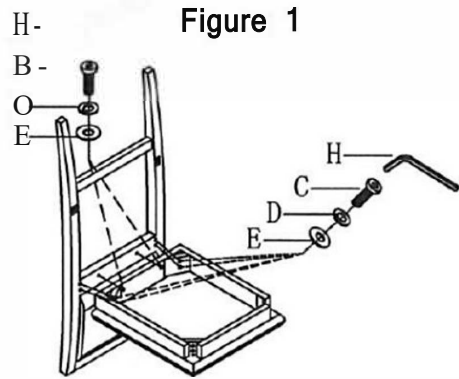

Figure 2

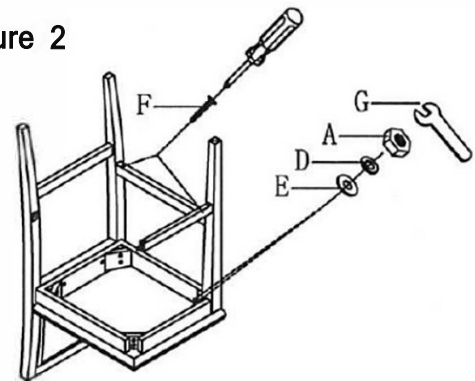
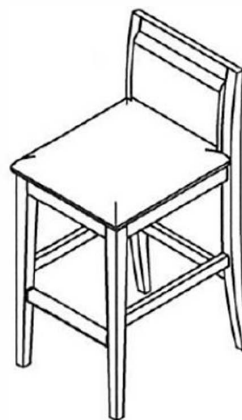
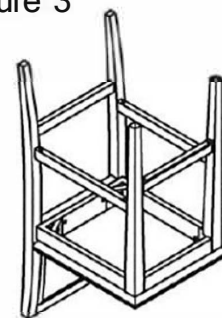

Figure 3



HARDWARE LIST			
A		Outer hexagon nut(115/16")	4pos
B		Countersink Bolt (115/16"x3-3/4")	2pos
C		Bolt (1215/16"x3-1/4")	4pos
D	☺	Lock Washer (1215/16")	10pcs
B	⊙	Flat Washer (1215/16")	10pcs
F	1-	Screw (C1>8x1-1/4")	6pcs
G		Spanner 5/16"	1pcs
H	--,	Allen Wrench (c1>1/4"*100*50mm)	1pca