

Home Office Desk

Assembly Instruction

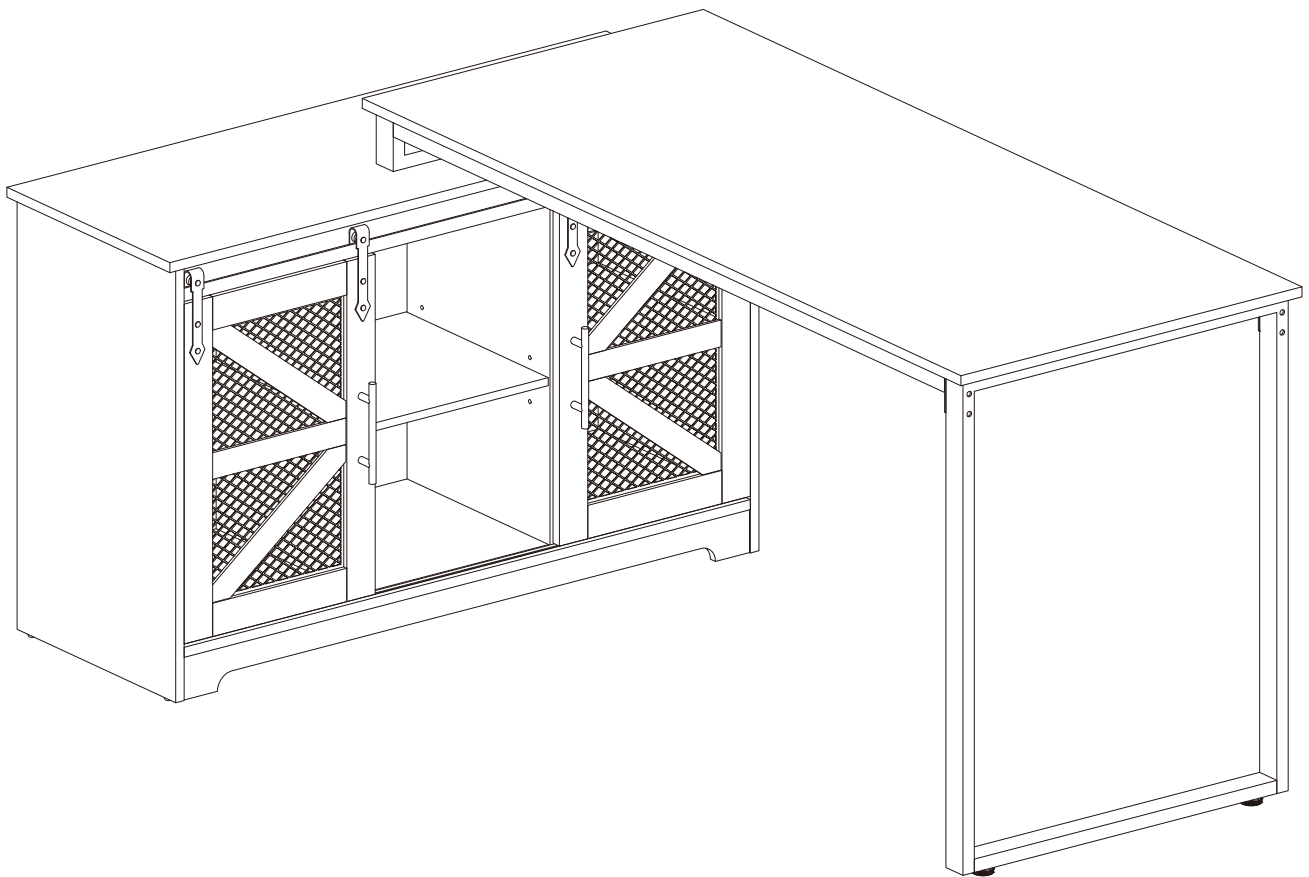

Please read all instructions and retain for future reference.

Take a few moments to familiarize yourself with the specific parts and hardware included with product. Make sure all the parts and hardware are included in the carton and examine them for any damage that may have occurred in transport. Do not dispose of the packaging until the desk is fully assembled and operational.

Follow basic safety precautions, including:

- The desk must be assembled by an adult.
- Do not allow children to play with the desk outside of its intended use.
- The desk can be used by children aged 8 years and above and persons with reduced physical, sensory or mental capabilities or lack of experience or knowledge if they have been given supervision or instruction concerning use of the desk in a safe way and understand
- If the supply cord is damaged it must be replaced by a service agent or a similarly qualified person to avoid a hazard.
- Dispose of packaging in line with your local authority guidance.
- DO NOT sit on the desk.
- Only use accessories supplied with the desk.
- Wipe clean with a soft damp cloth, never use abrasive cleaners as this could damage the desk.
- Do not attempt to move the product whilst plugged in or in use.
- Do not remove the product from the mains power supply by pulling the cord; switch it off and remove the plug by hand.
- Do not leave the desk unattended whilst connected to the mains.

Please read this manual carefully before any operation and keep it properly for future use.

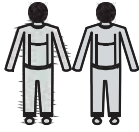
 <p>60 MIN Assembly Time</p>	 <p>2 Two Persons</p>
---	--

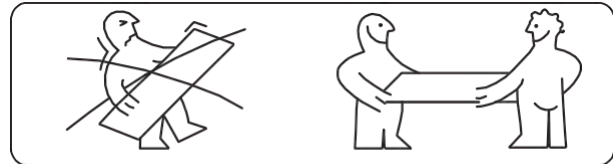
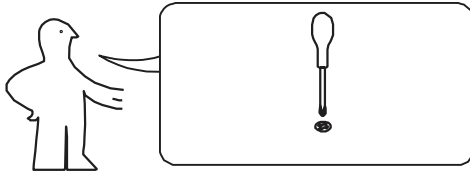

① Safe carriage, multi-people are needed.

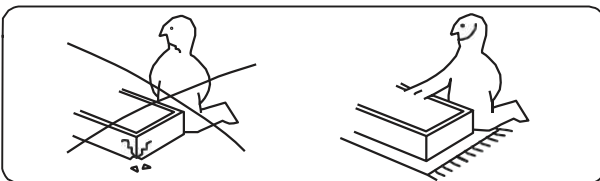

② Handle with care, protective layer is required.

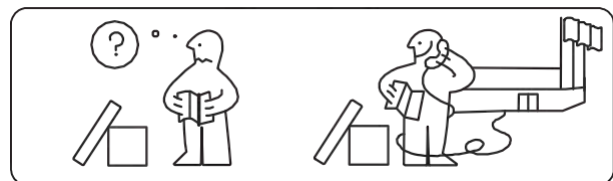

③ In case of any doubts, contact customer service.

Safe carriage, multi-people are needed.

Handle with care, protective layer is required.

In case of any doubts, contact customer service.

Included Hardware

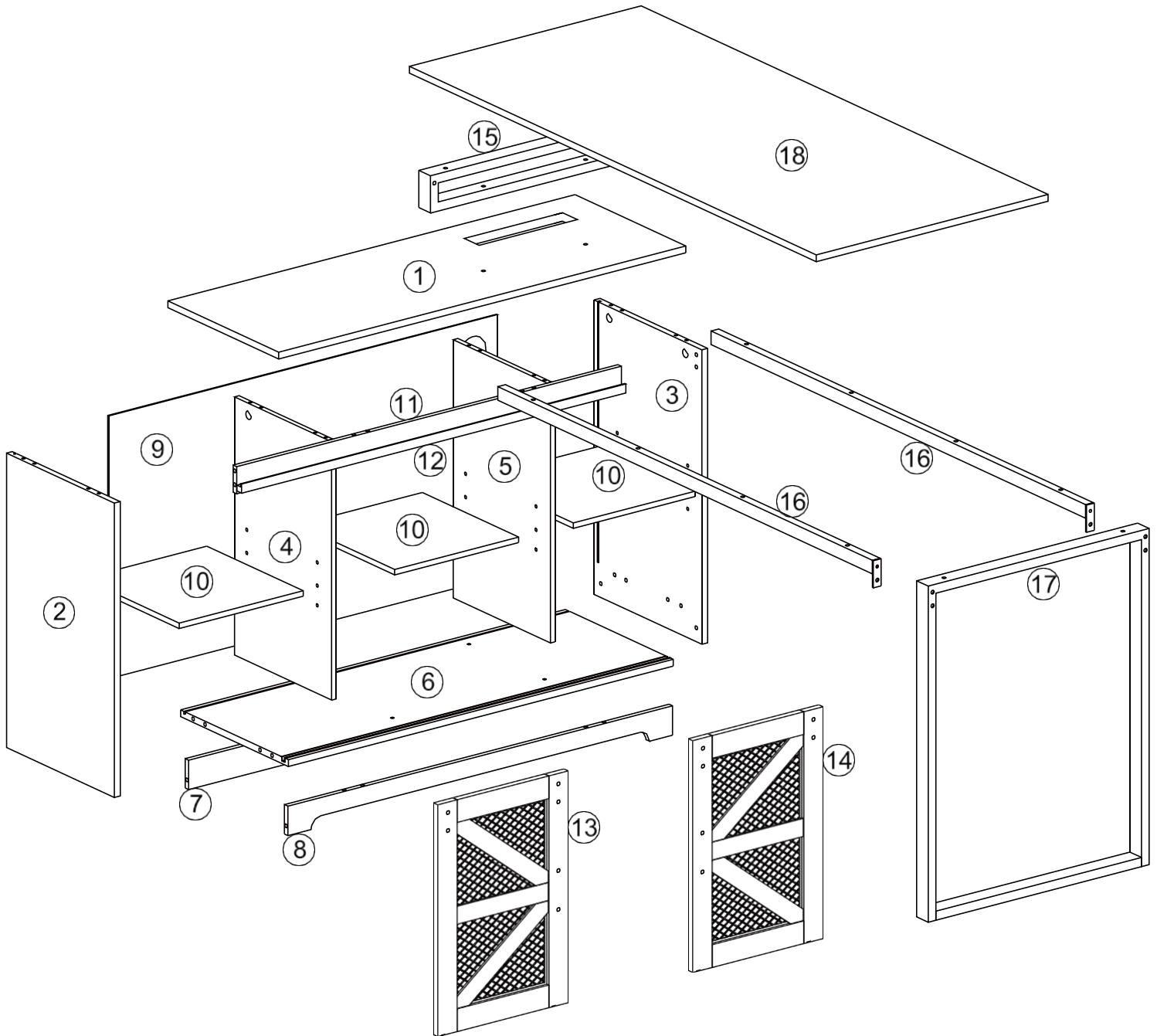

Parts List

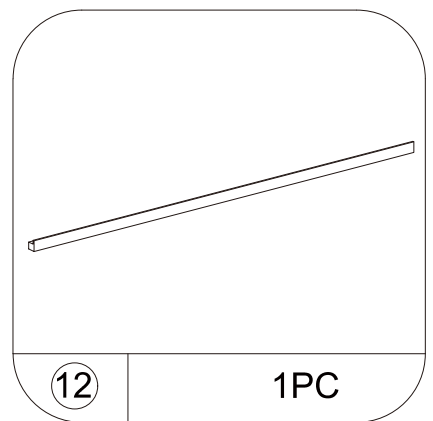
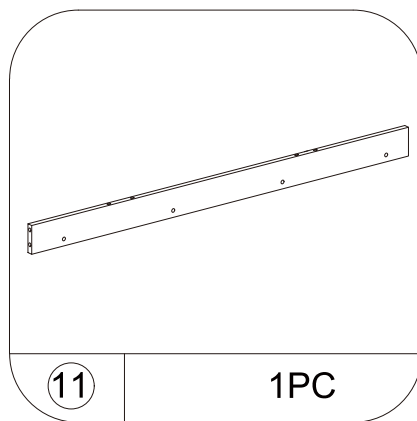
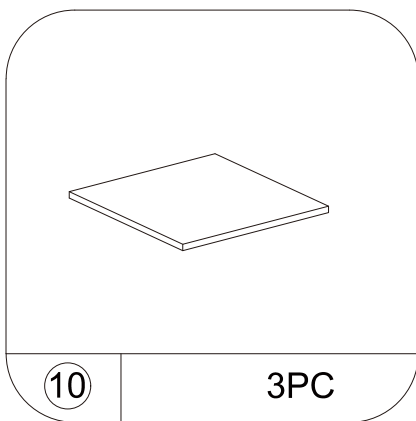
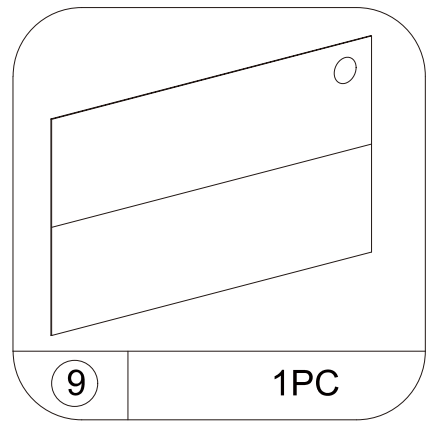
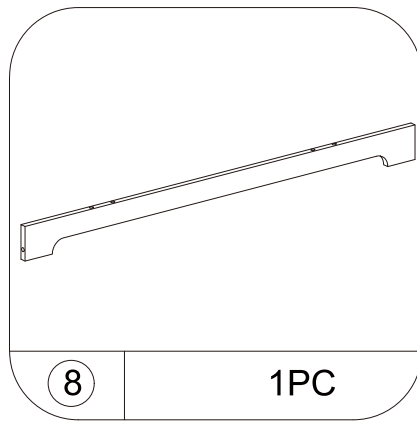
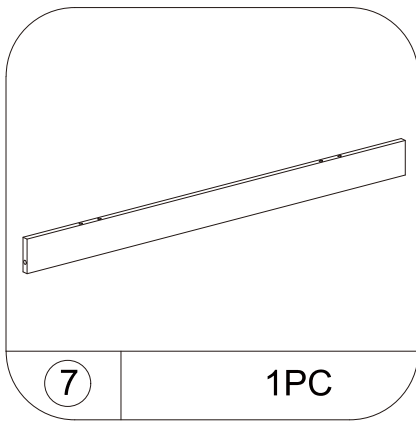
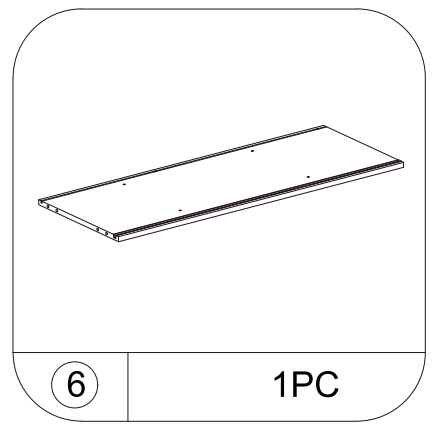
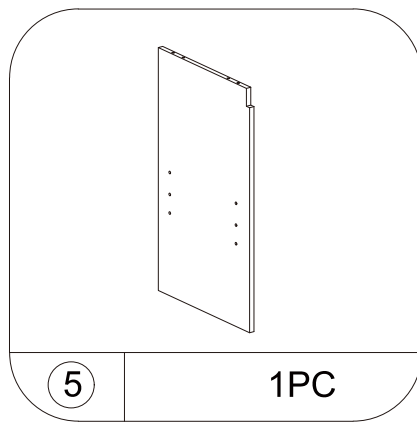
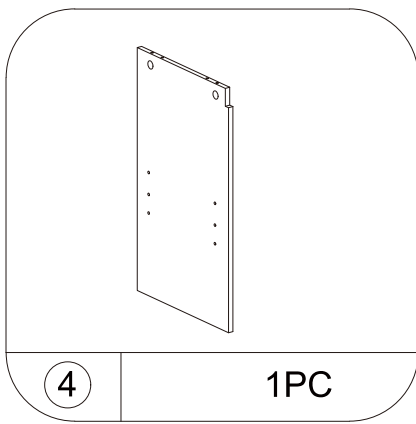
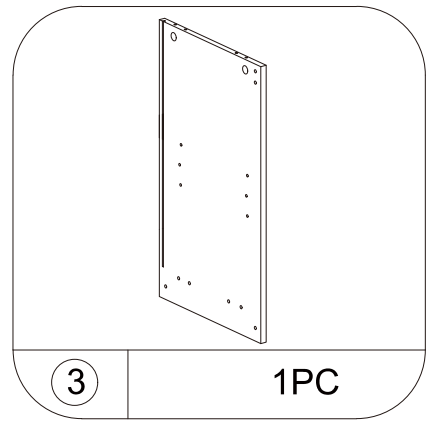
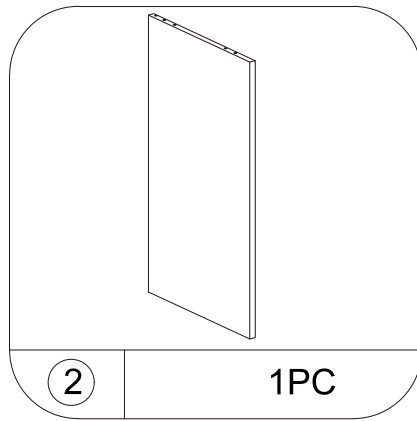
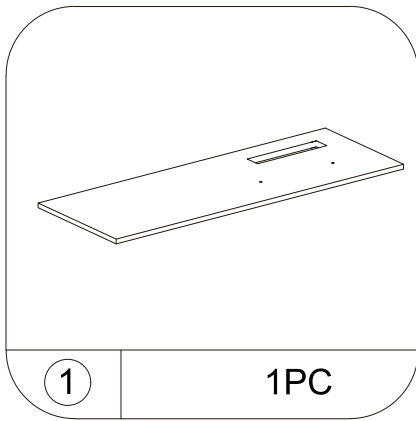

Parts List

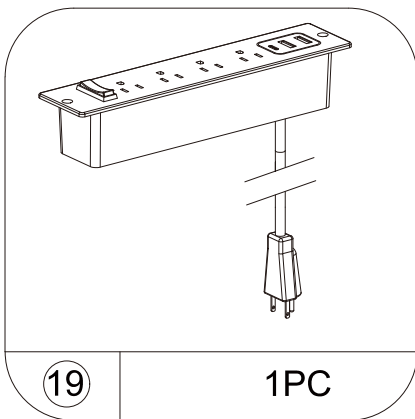
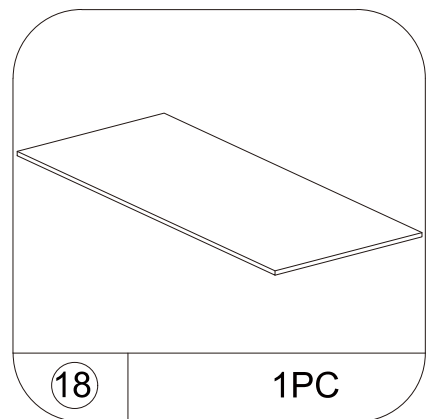
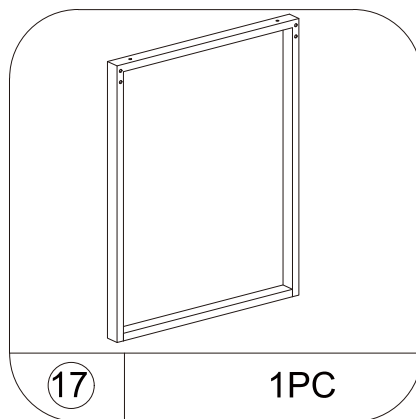
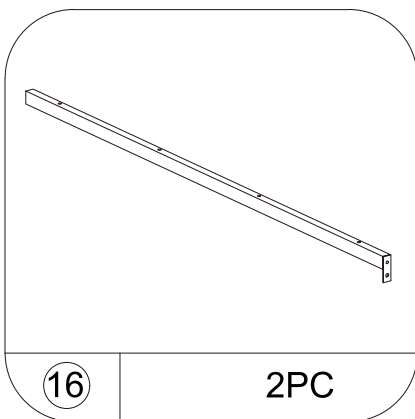
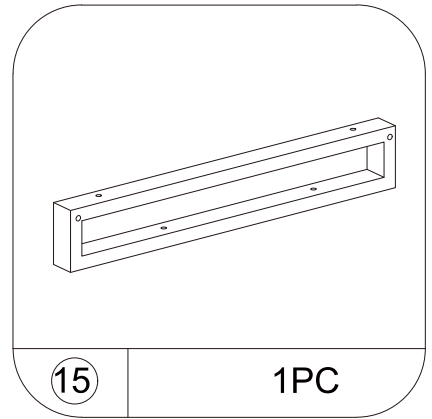
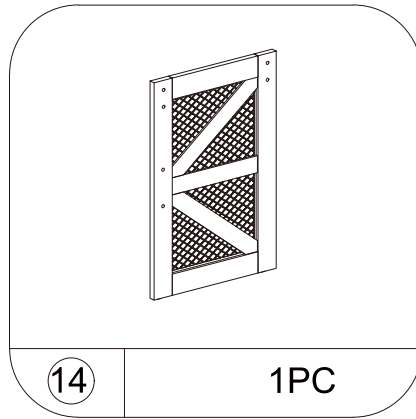
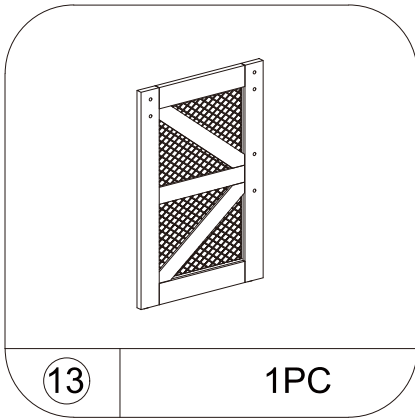

Parts List

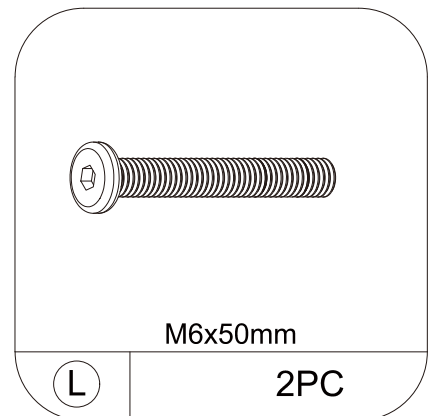
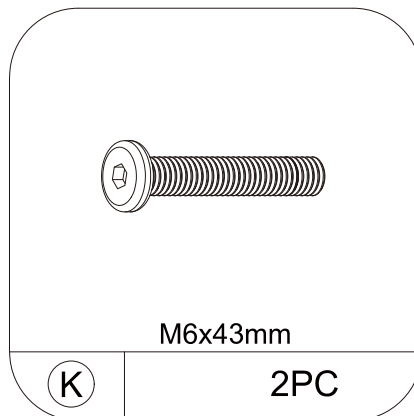
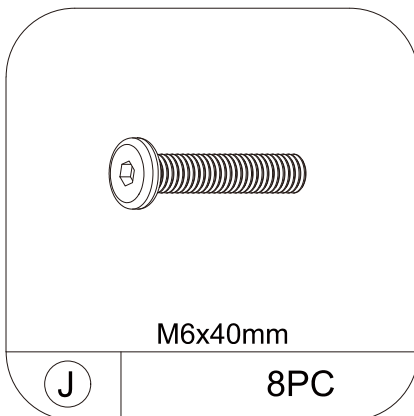
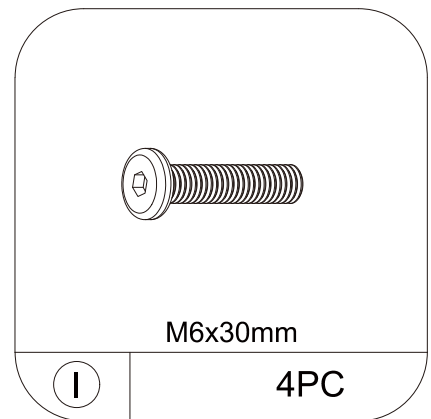
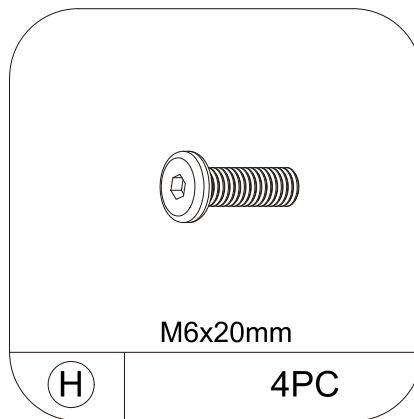
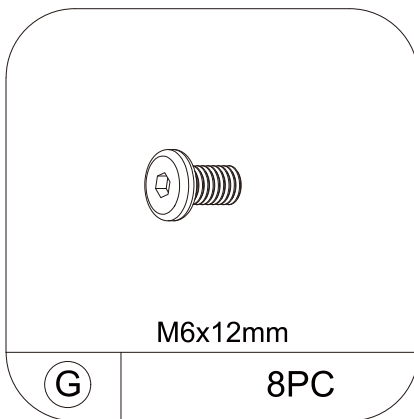
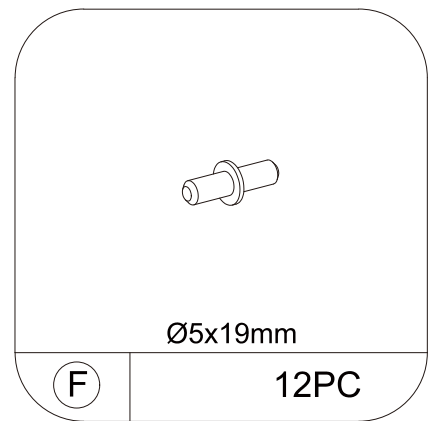
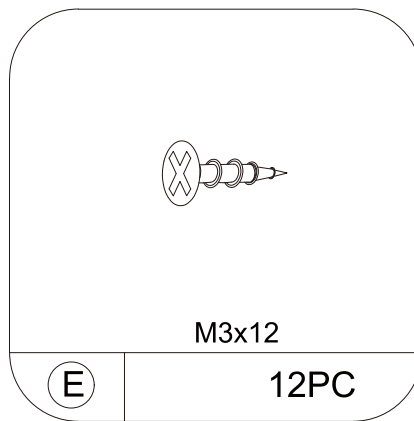
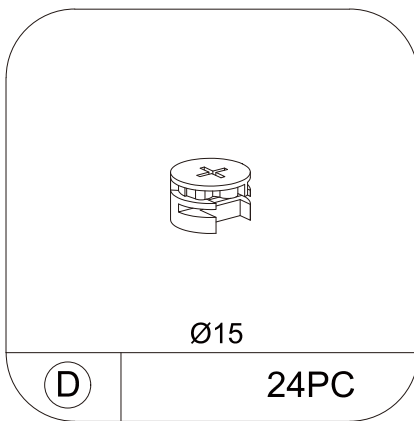
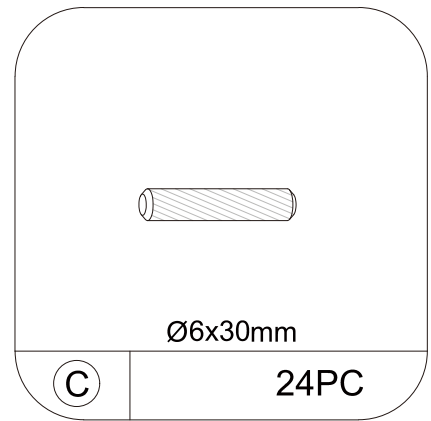
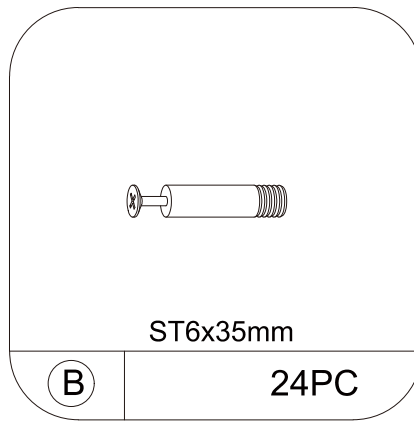
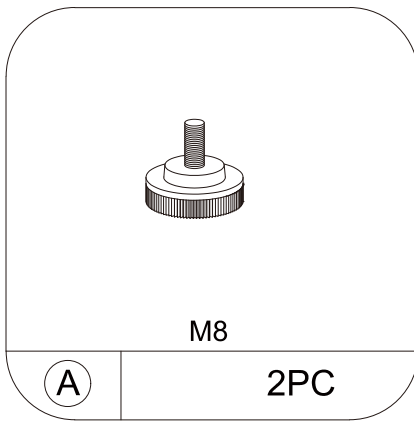

Parts List

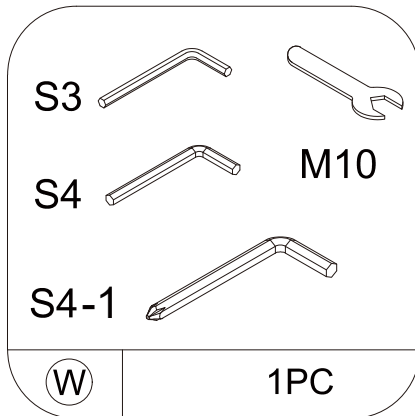
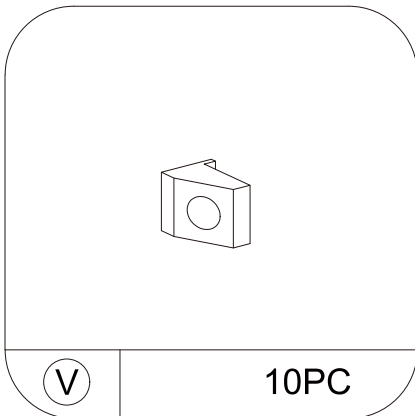
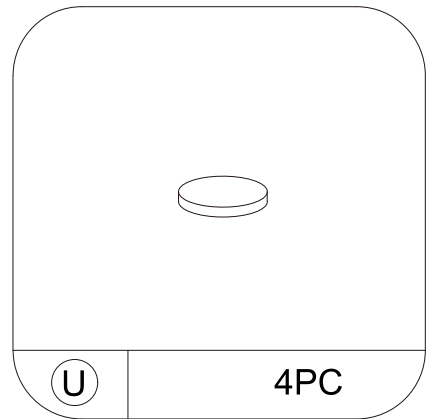
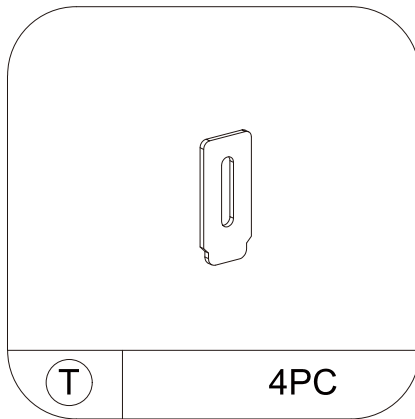
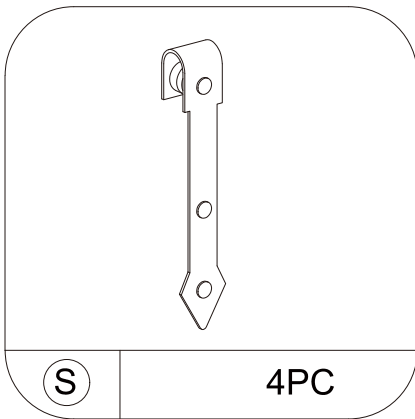
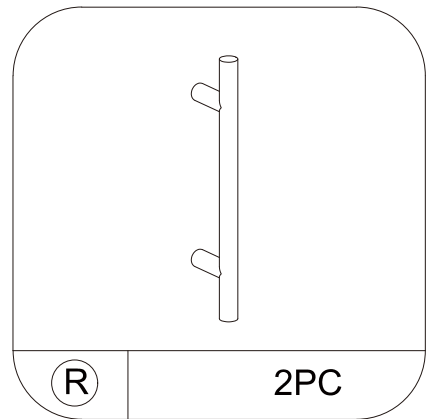
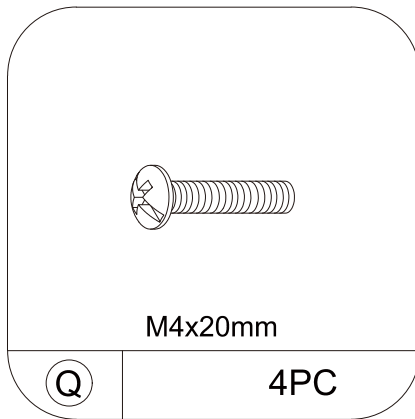
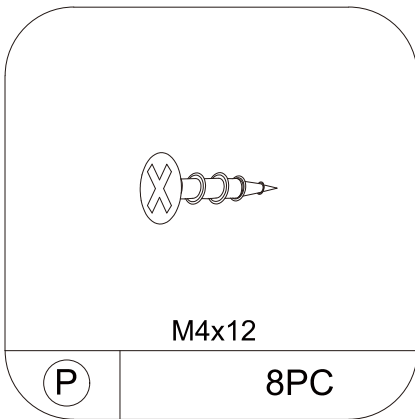
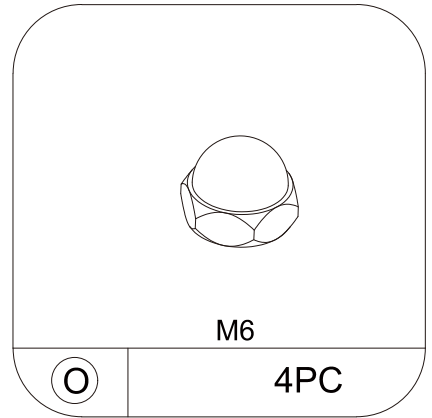
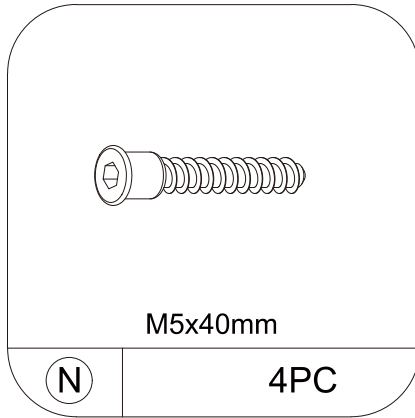
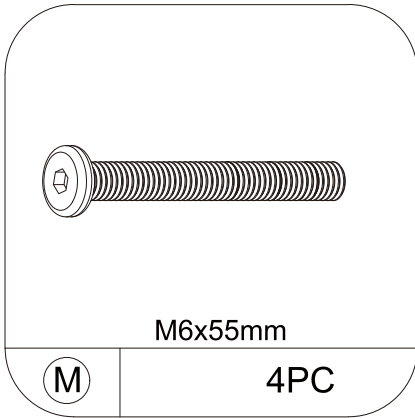

STEP 1

Don't mistake the position of cam screws B and wood dowels C.

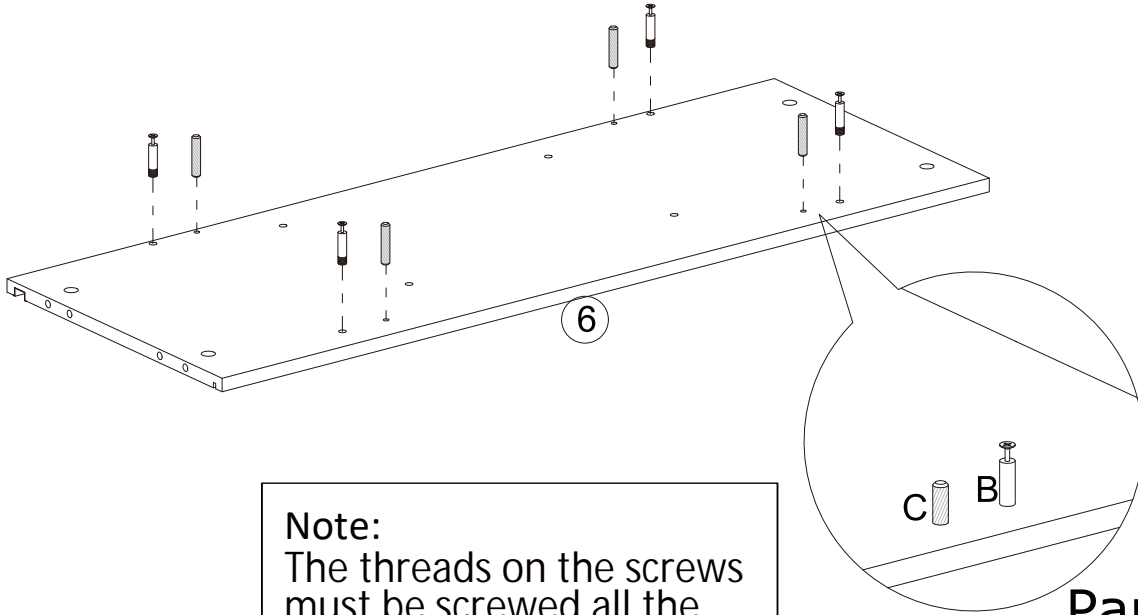

Note:
The threads on the screws must be screwed all the way into the panel!!

Parts Need:

Panel ⑥ 1PC

Ⓑ  4PC

Ⓒ  4PC

STEP 2

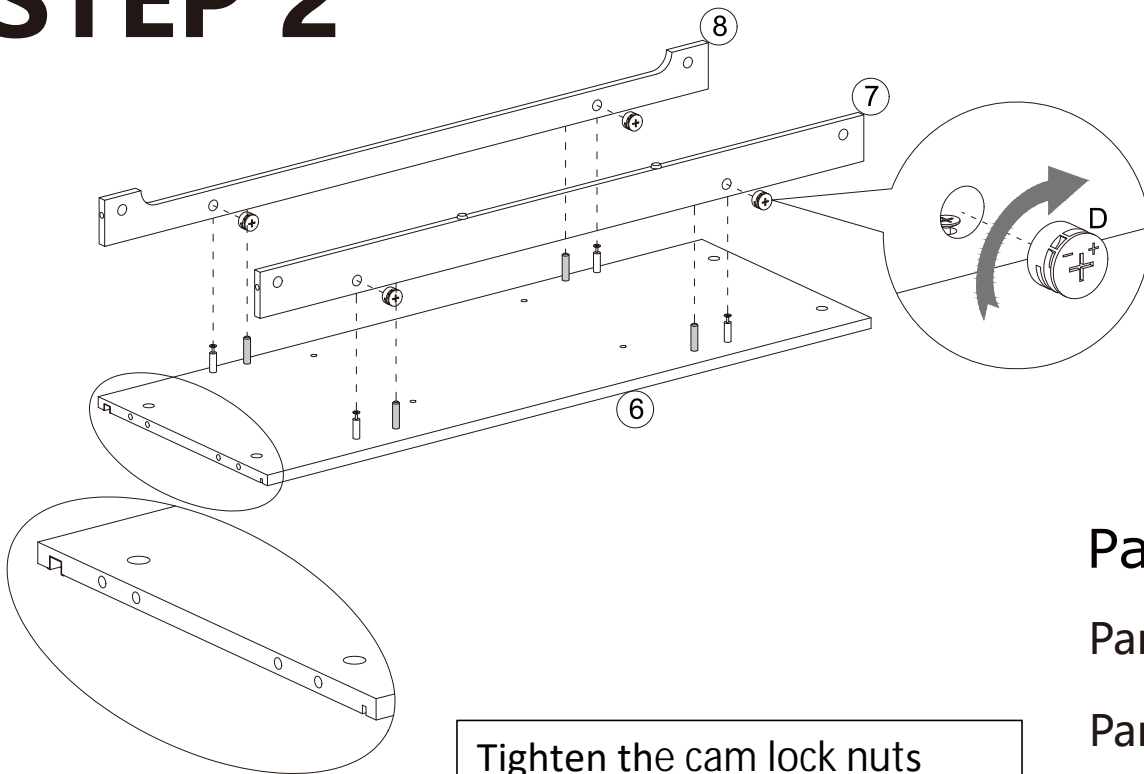

Tighten the cam lock nuts clockwise with wrench S4-1.

Parts Need:

Panel ⑦ 1PC

Panel ⑧ 1PC

Ⓓ  4PC

STEP 3

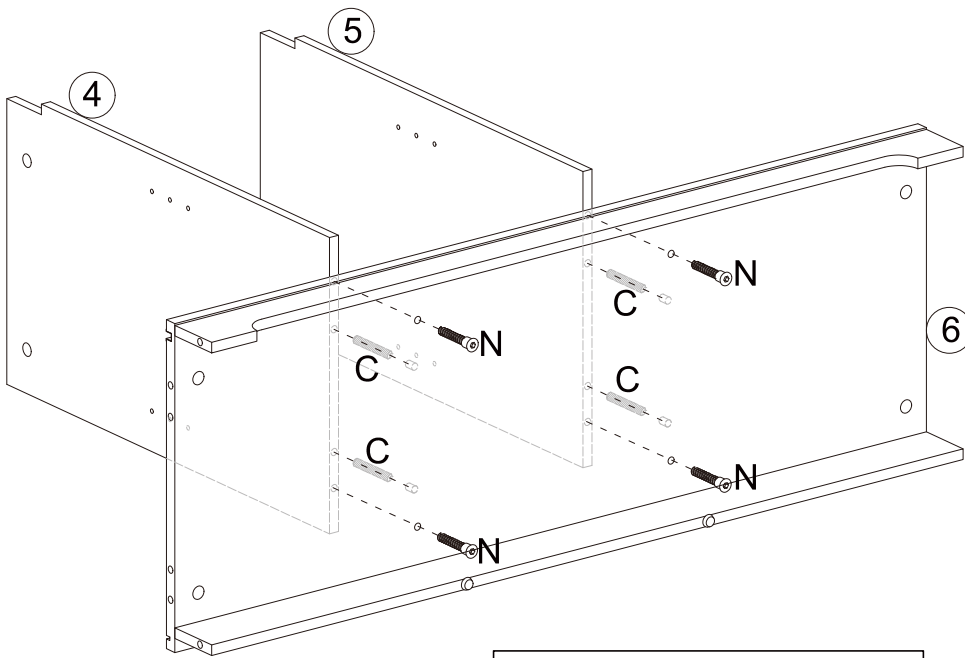

Note: Panels ⑦ and ⑧ are facing outward.

Parts Need:

Panel ④ 1PC

Panel ⑤ 1PC

③ 4PC

④ 4PC

STEP 4

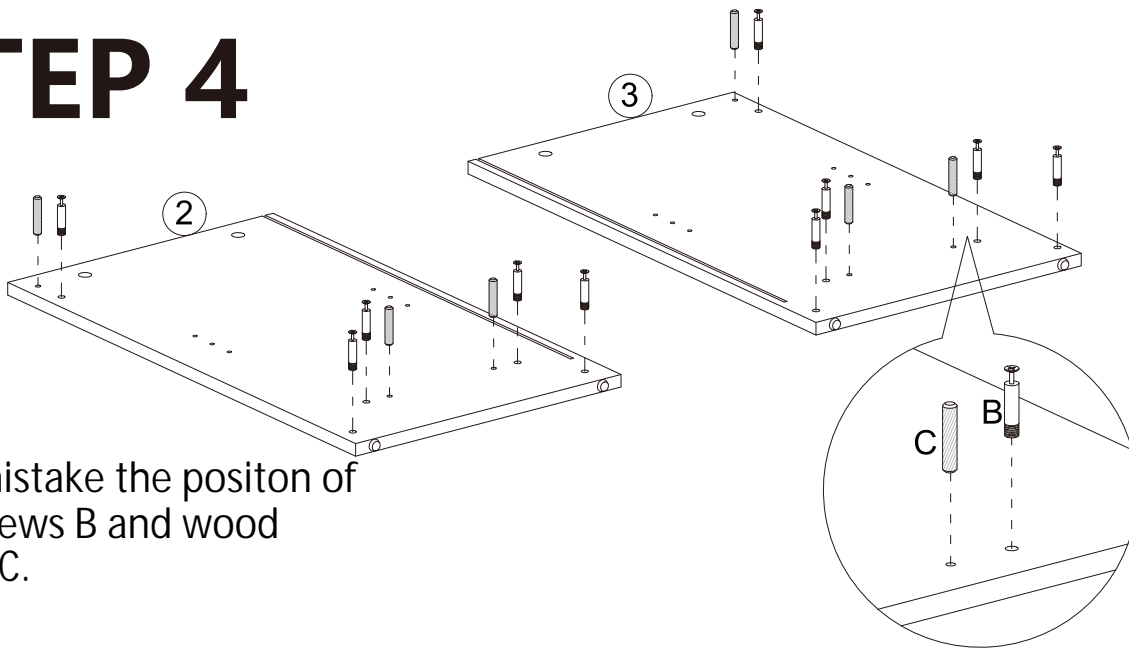

Don't mistake the position of cam screws B and wood dowels C.

Note:
The threads on the screws must be screwed all the way into the panel!!

Parts Need:

Panel ② 1PC

Panel ③ 1PC

⑤ 10PC

⑥ 6PC

STEP 5

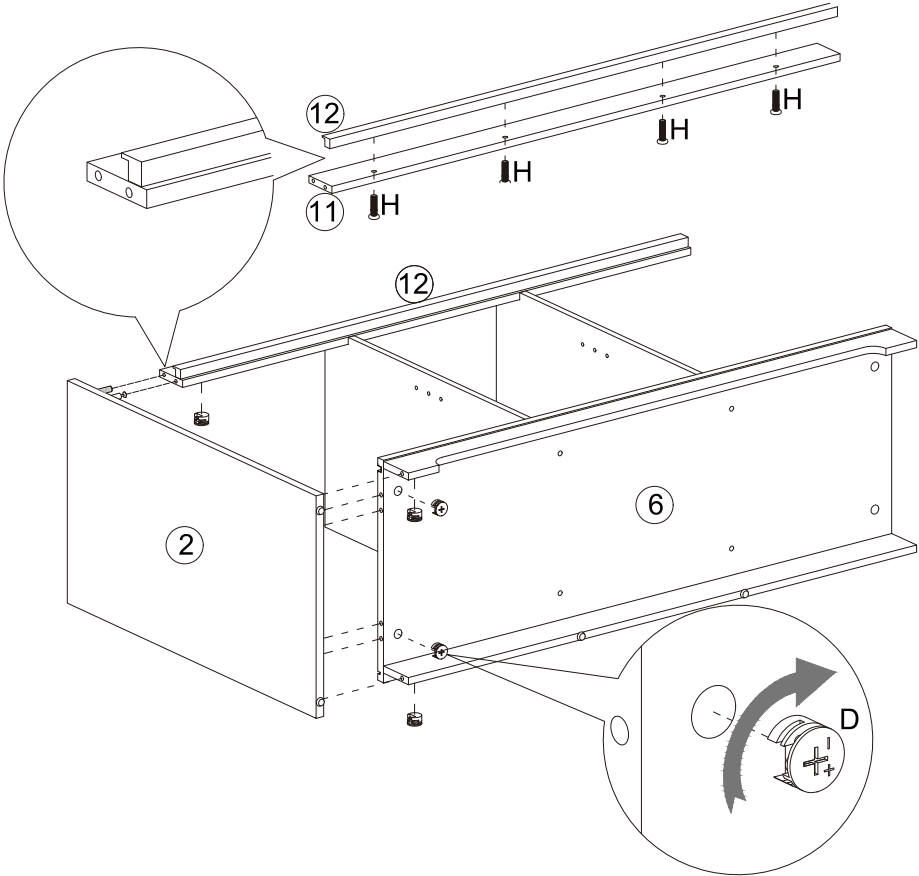

Parts Need:

- Metal Strap ⑫ 1PC
- Panel ⑪ 1PC
- Panel ② 1PC
- Panel ⑥ 1PC

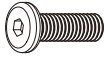
- ⓓ  5 PC
- ⓓ  4PC

STEP 6

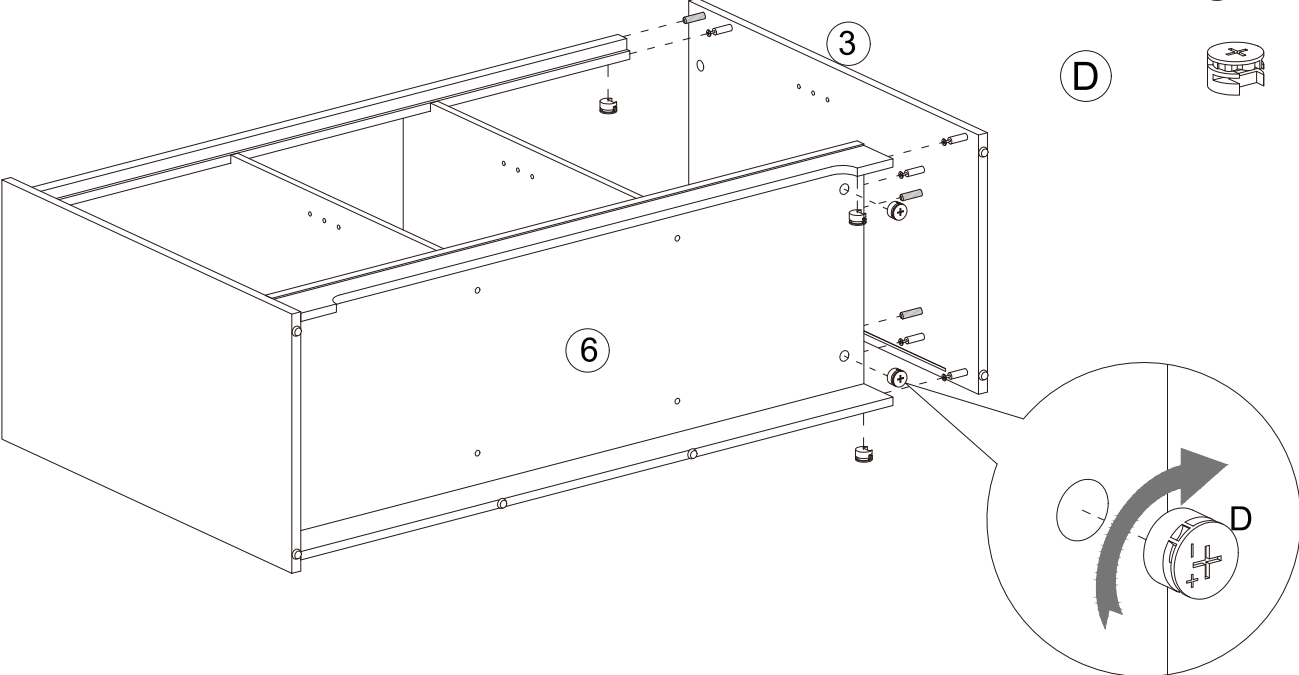

Parts Need:

- Panel ③ 1PC
- ⓓ  5PC

STEP 7

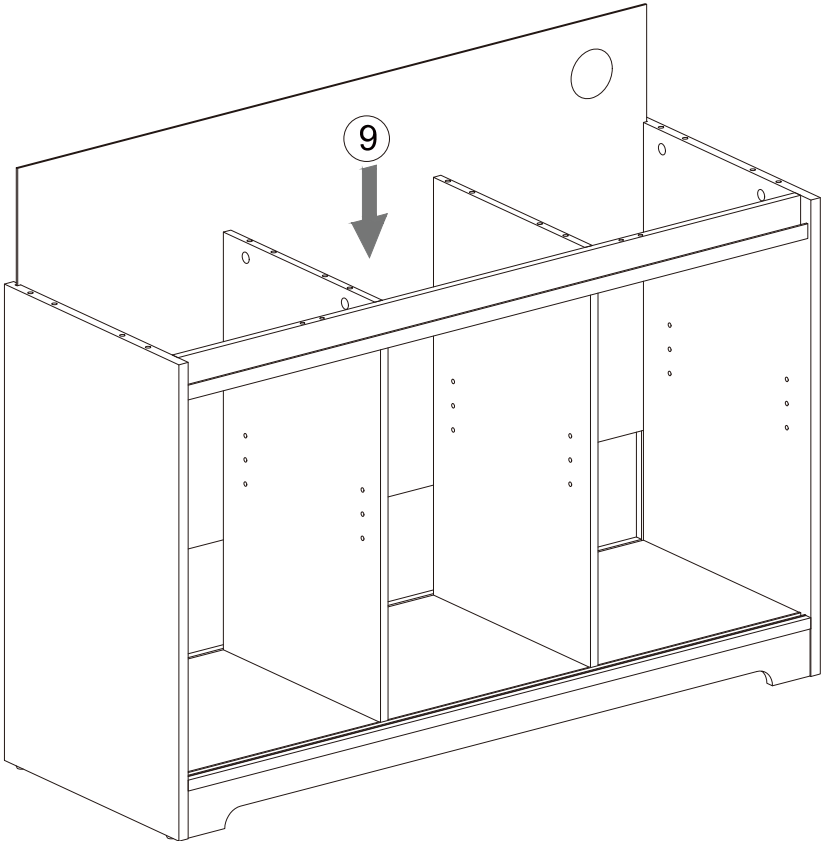

Parts Need:

Panel ⑨ 1PC

STEP 8

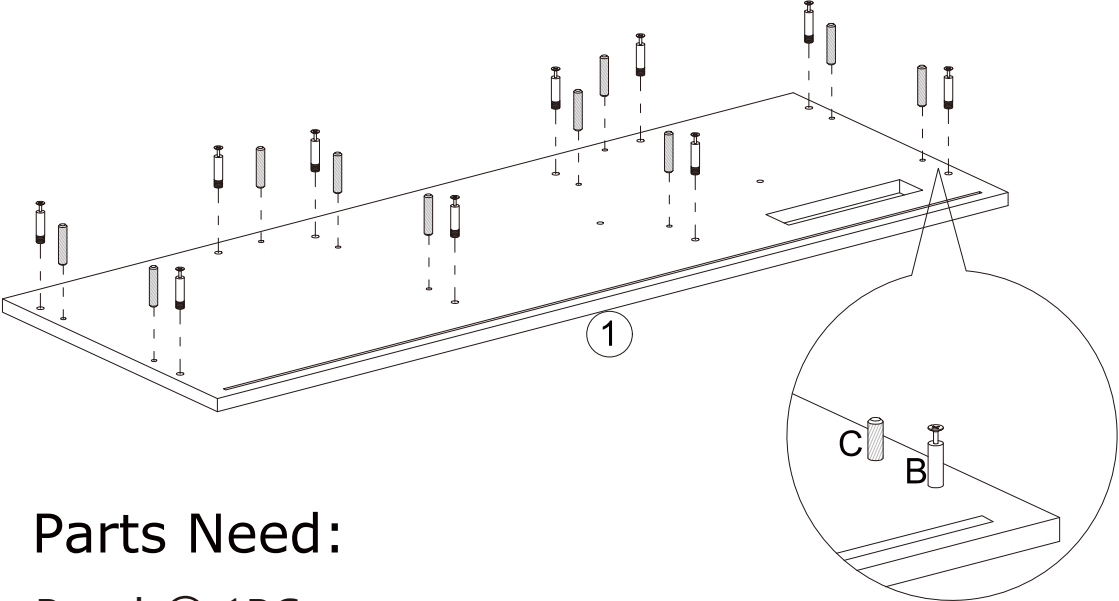

Parts Need:

Panel ① 1PC

ⓑ  10PC

ⓒ  10PC

Note:
The threads on the screws
must be screwed all the way
into the panel!!

STEP 9

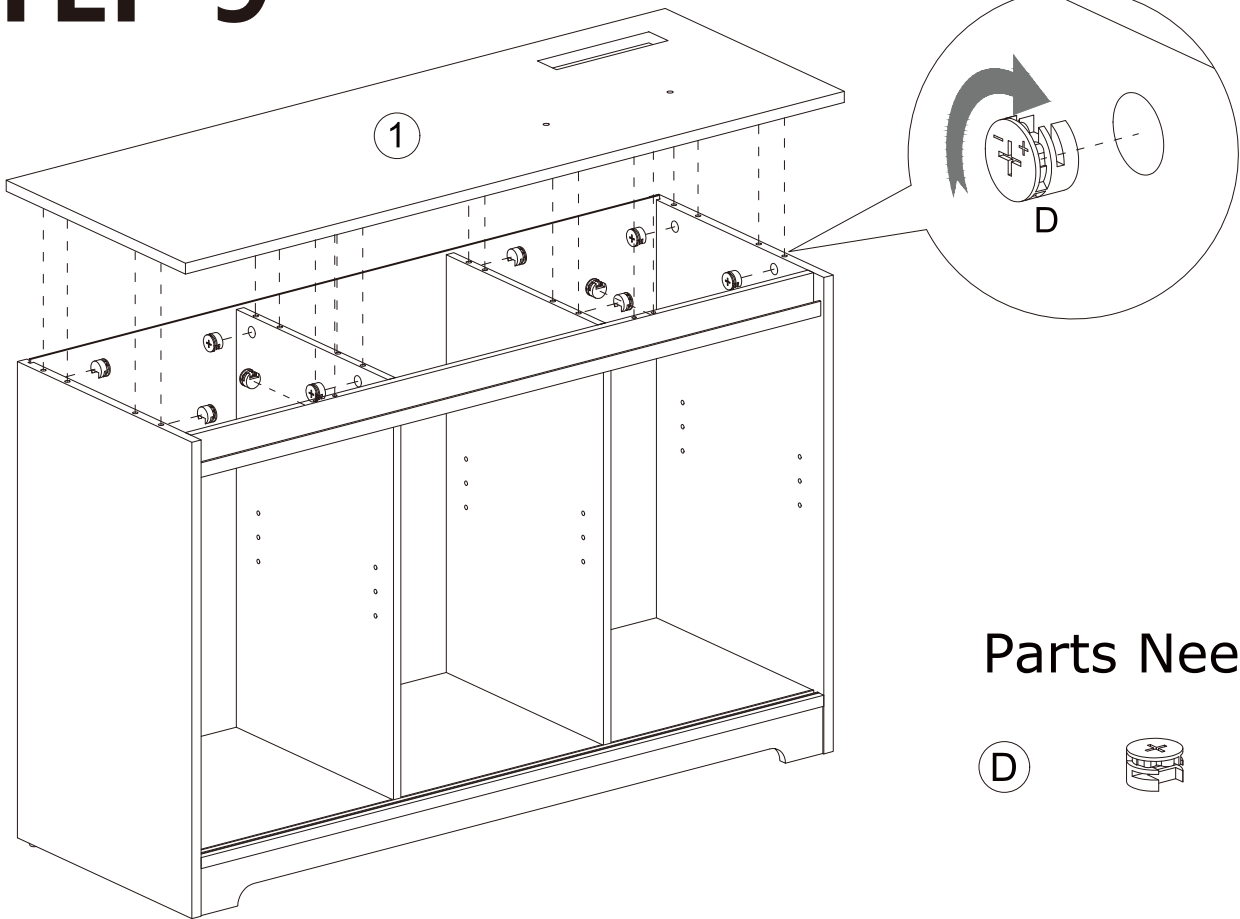

Parts Need:

Ⓓ  10PC

STEP 10

Note:
Need to use a hammer to tap the shelf support nails F to get them secured in the Panel.

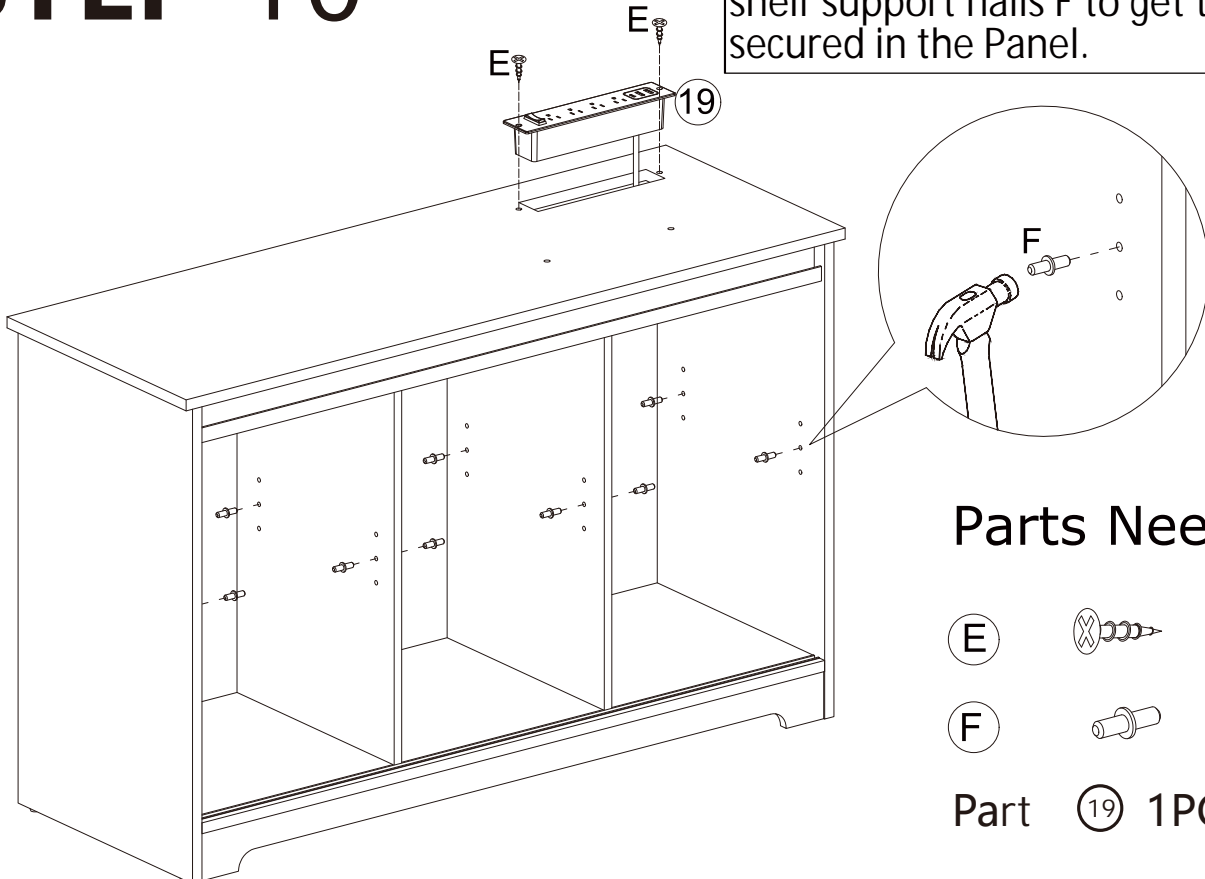

Parts Need:

Ⓔ  2PC



Ⓕ  12PC

Part Ⓘ 1PC

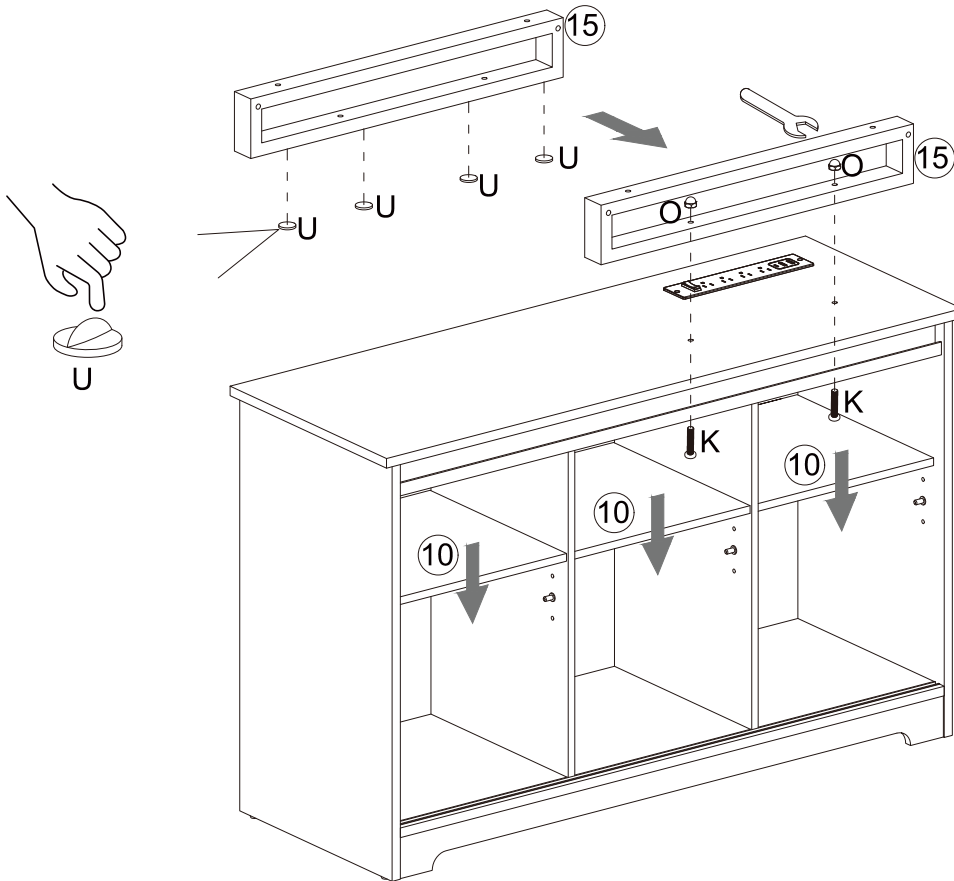
STEP 11







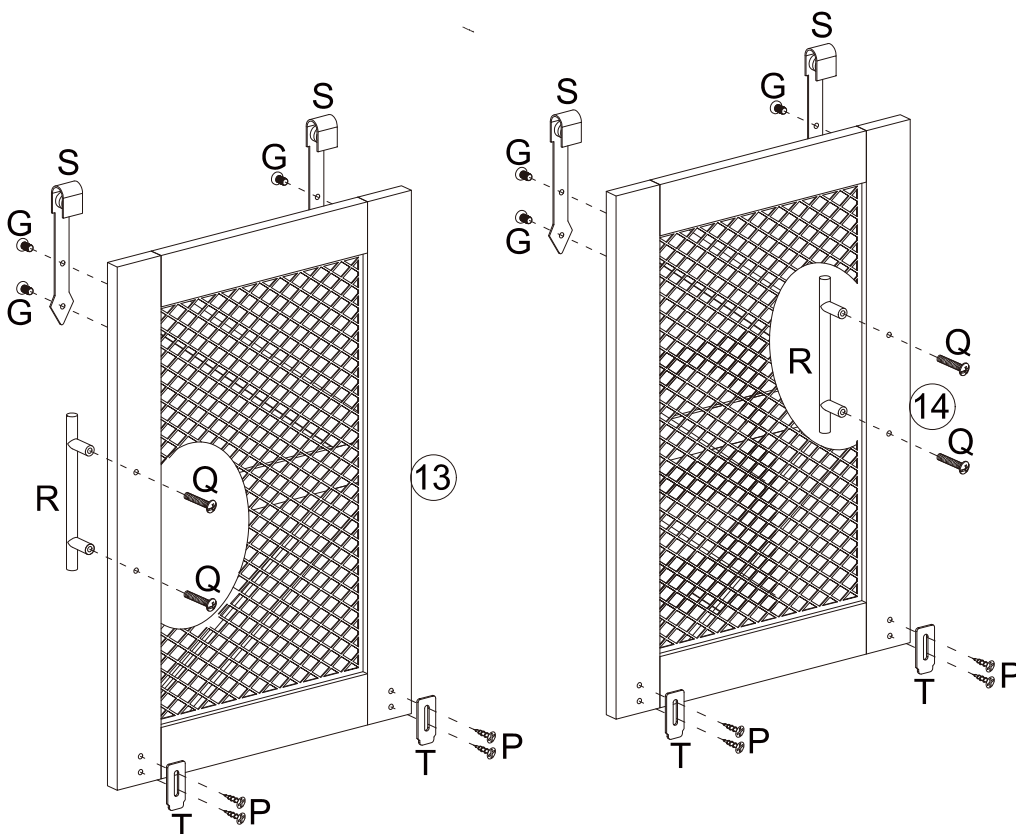

Parts Need:

- Part ⑩ 3PC
- Part ⑮ 1PC
- ① K  2PC
- ① O  2PC
- ① U  4PC

STEP 12

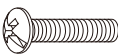

Parts Need:

- ① G  8PC
- ① P  8PC
- ① Q  4PC
- ① R  2PC
- ① S  4PC
- ① T  4PC

Part ⑬ 1PC

Part ⑭ 1PC

STEP 13

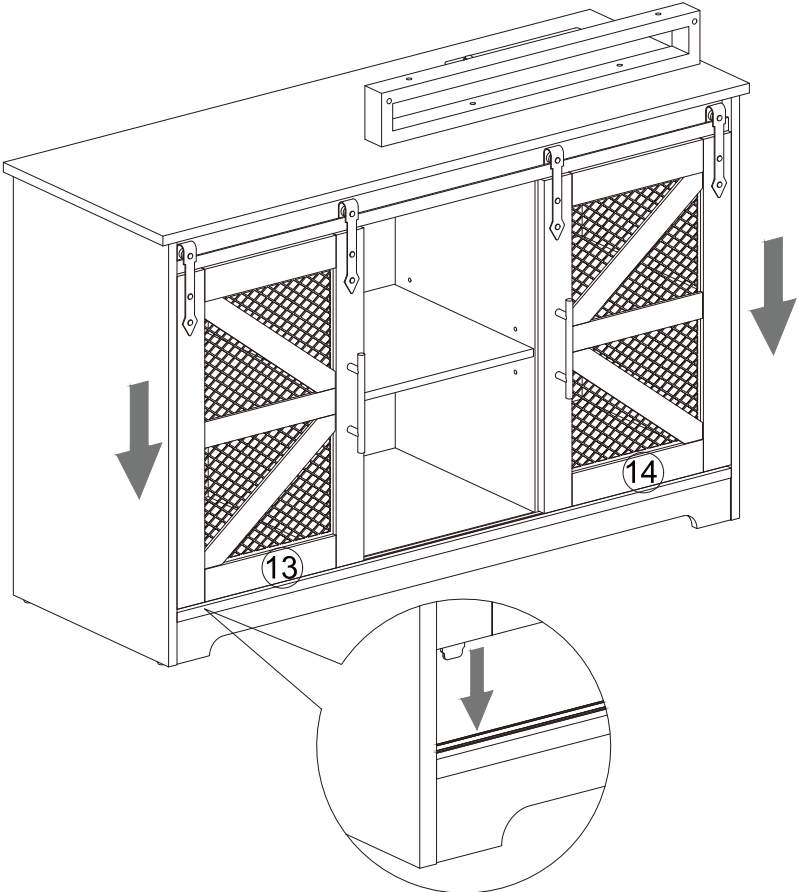

STEP 14

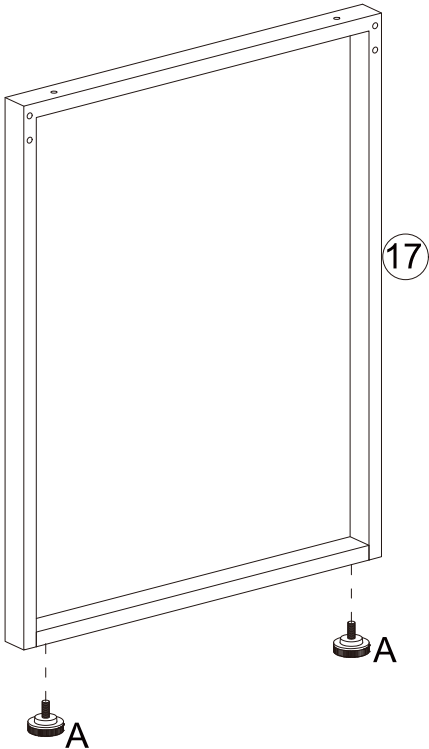

Parts Need:



(A)  2PC

Part (17) 1PC

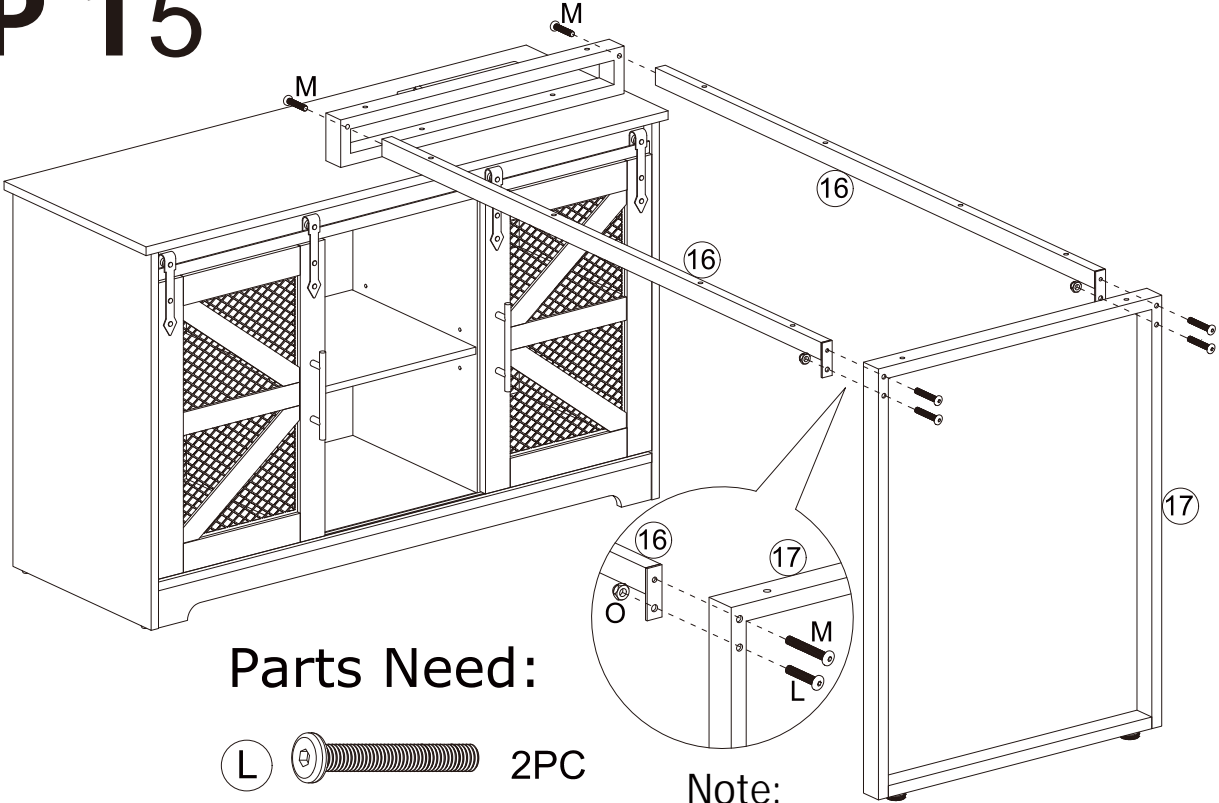
STEP 15



Parts Need:

- (L)  2PC
- (M)  4PC
- (O)  2PC



Note:
Upper with bolts M
Lower with bolts L

Part (16) 2PC

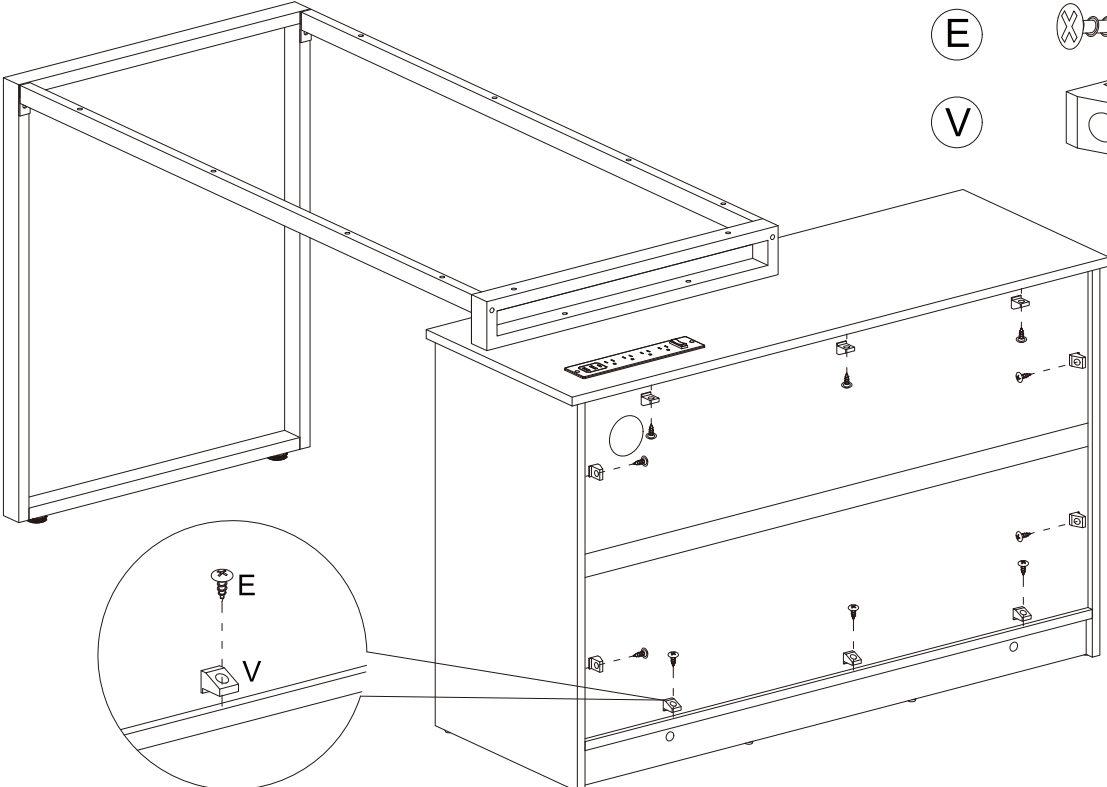
STEP 16



Parts Need:

- (E)  10PC
- (V)  10PC

STEP 17

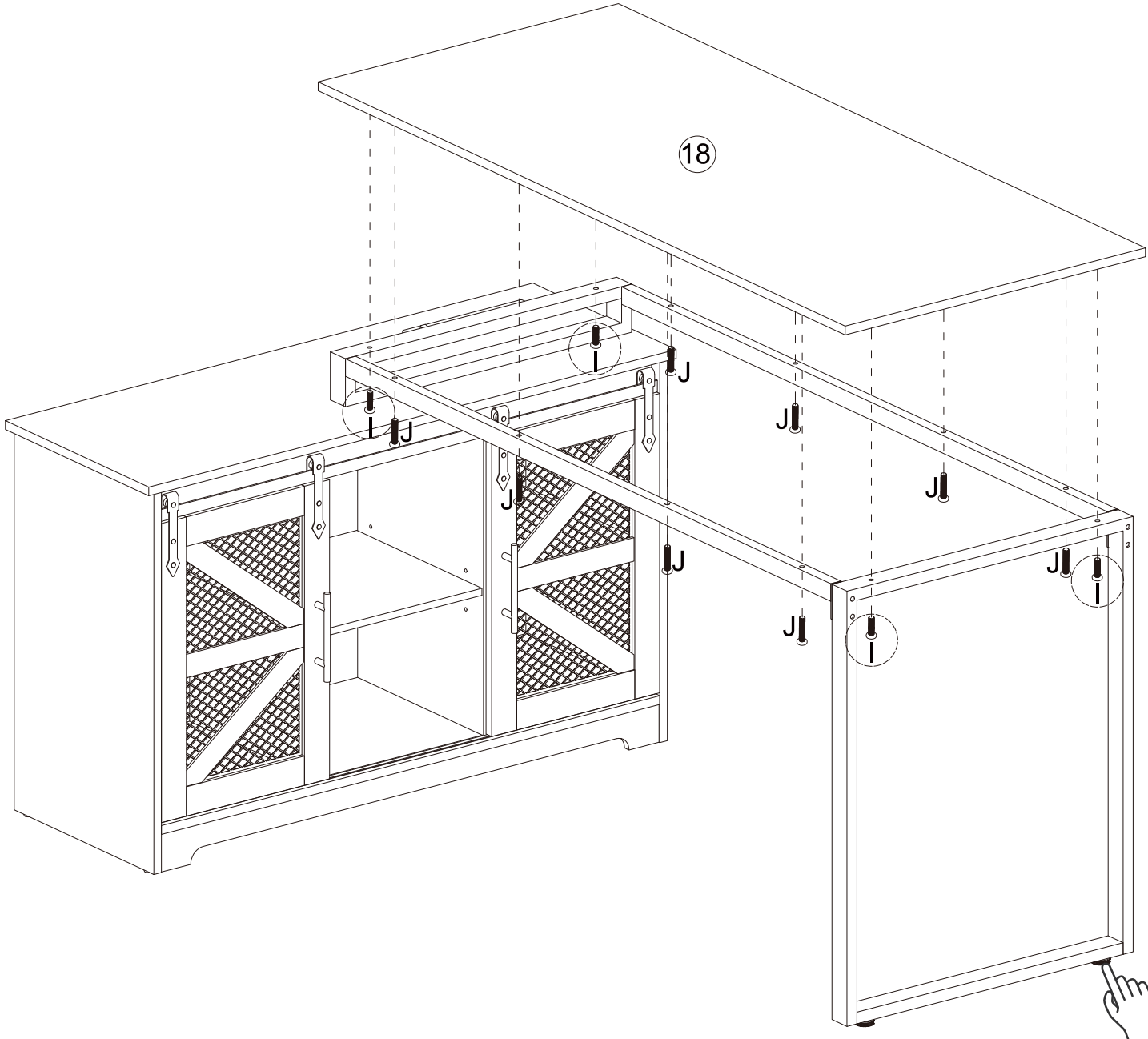

If unstable, please adjust these adjusting feet.

Parts Need:

①  4PC

②  8PC

Panel ③ 1PC

WARRANTY

Thank you for purchasing the Product. We promise to repair or replace any product or component that may have any defects in material or workmanship for as long as you, the original purchaser, own it.

There are no other warranties except as expressly set forth below, either expressed or implied, including any warranty of merchantability for any particular purpose.

The word defects in this warranty is defined as imperfections that impair the service, function or effectiveness of the product.

INFORMATION ON COLOR VARIATIONS & FINISHES:

Some natural variations occurring in wood, or other natural materials are inherent to their character, and thus can not be avoided. Therefore they are not considered to be defects. Does not warrant the color fastness or matching of colors, grains, textures or other such materials. Customers' own materials selected by and used at the request of a user is therefore not warranted.

LIMITATIONS INVOLVING MATERIALS & COMPONENTS:

The materials and all components listed below are covered according to the following schedule from the date of sale to the original purchaser.

EXCLUSIONS:

This warranty does not apply to: damage caused by the carrier, modifications to the product, or attachments to the product not approved, non-standard materials selected by and used at the request of a user, and products that were not installed, used or maintained in accordance with product instructions and warnings. Nor shall we have any responsibility for incidental or consequential damages resulting from the breach of this Warranty, including but not limited to inconvenience, rental or purchase of replacement products, loss of profits or commercial loss. Some states or provinces do not allow the exclusion or limitation of incidental or consequential damages so the above limitation or exclusion may not apply to you. This warranty gives you specific legal rights and you may also have other rights, which may vary from state to state or province to province. This warranty applies only to products sold within the United States of America and the Commonwealth of Canada.

TO OBTAIN SERVICE FROM THIS WARRANTY:

A) Please contact us within 30 days (unless otherwise noted by the Dealer) of discovery of the defect. Prepare to confirm that you are the original purchaser of the product and provide necessary product information, such as order number

B) Will gather all the pertinent information required regarding your claim(s), inspect the product and thus contact a Customer Service Representative.

C) If confirms that the product in review is eligible under the warranty conditions as stated above, the Customer Service Representative or another representative of the Company will determine whether to provide replacement parts, or authorize other arrangements at the sole discretion of the vendor. No assembly/labor is included in this warranty.

Our knowledgeable Service Representatives are ready to assist you in the case this warranty applies to you. Please be prepared to explain the defect in detail, model/style number, date, your name and order number.