

Assembly Instructions

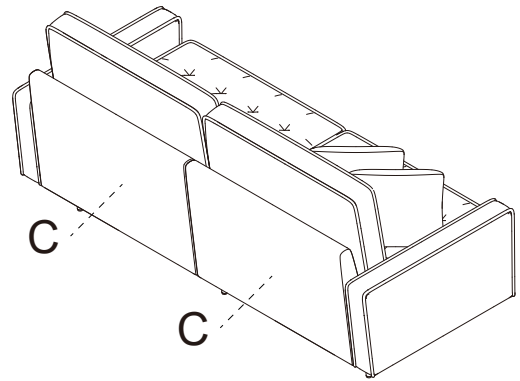

Assemble on the pad to prevent scratching the product.
Do not tighten all screws before instructions prompt.

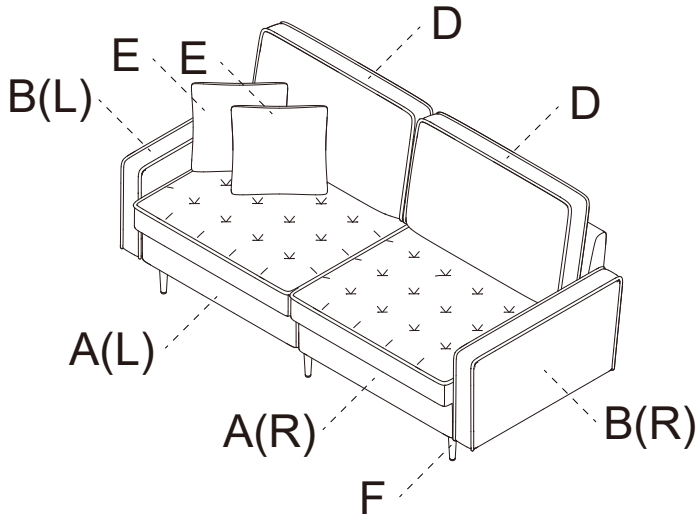

Parts List

Open the hardware check all parts QTY, thanks

1/2
carton

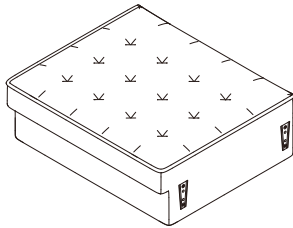

A(R) x 1
(Seat)

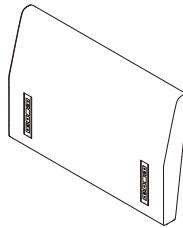

C x 1
(Back)

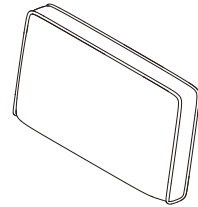

D x 1
(Cushion)

In the bottom of "A(R)"

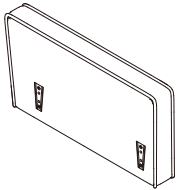

B(R) x 1
(Armrest)

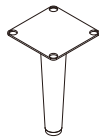

F x 6
(Legs)



G x 24
(Screws)

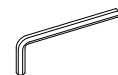

H x 1
(Wrench)

2/2
carton

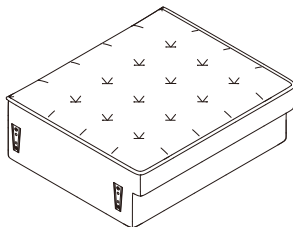

A(L) x 1
(Seat)

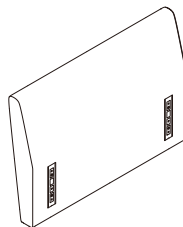

C x 1
(Back)

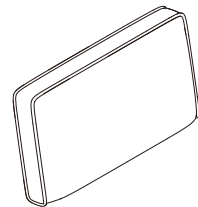

D x 1
(Cushion)

In the bottom of "A(L)"

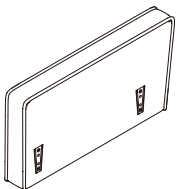

B(L) x 1
(Armrest)



E x 2
(Pillow)

Step 1

1. Open the velcro on bottom of "A(R)".
2. Take out "B(R)", "F", "G", "H".

3. Open the velcro on bottom of "A(L)".
4. Take out "B(L)", "E".

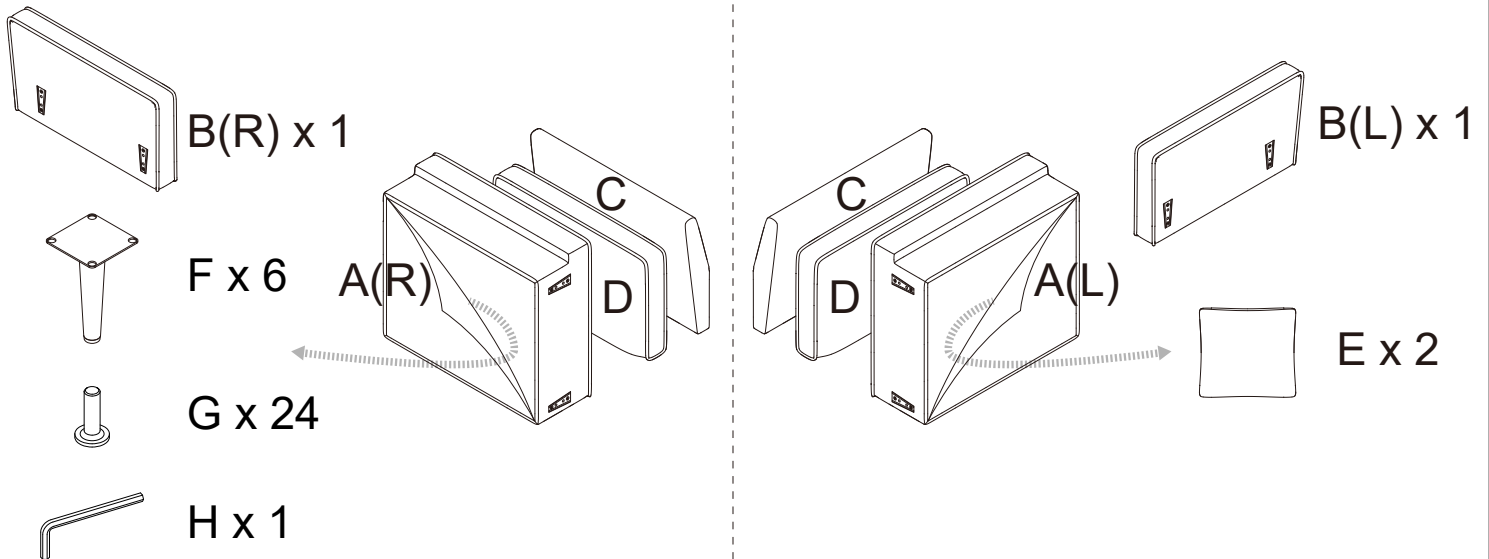

Step 2

1. Four screws "G x 4" through the four drilled holes of one leg "F".
2. Screwing in any bottom of "A(R)", "A(L)".
3. Wrench "H" tighten clockwise four screws.
4. Repeat the above operation until all legs are installed.
5. Close the velcro on bottom of "A(R)", "A(L)".

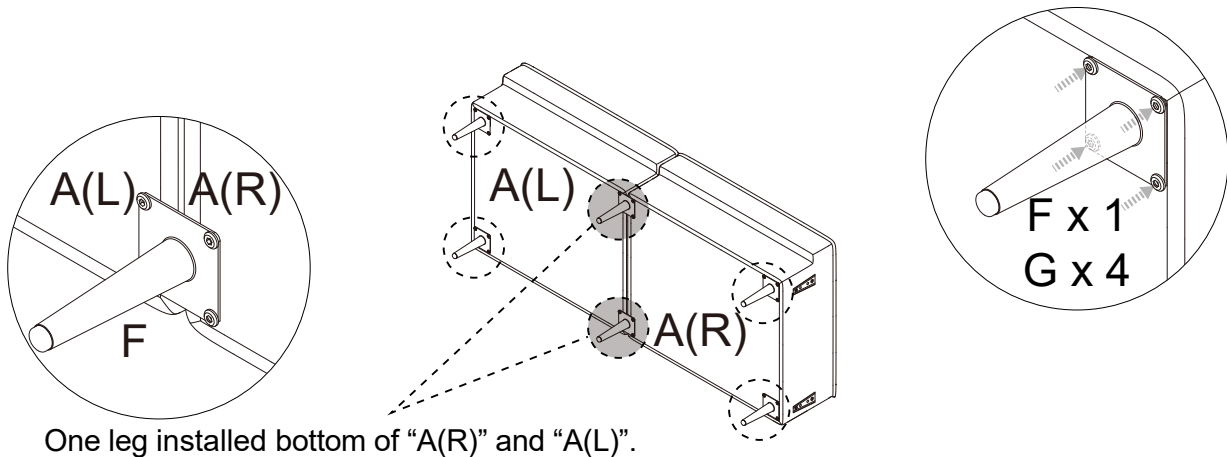

Step 3

1. Press "C" inserting pieces into "A(R)" slots.
2. Press "C" inserting pieces into "A(L)" slots.
3. Press "B(R)" inserting pieces into "A(R)" slots.
4. Press "B(L)" inserting pieces into "A(L)" slots.

5. Place the "D".
6. Place the "E".

