

# ***Instructions***

ASSEMBLY INSTRUCTIONS

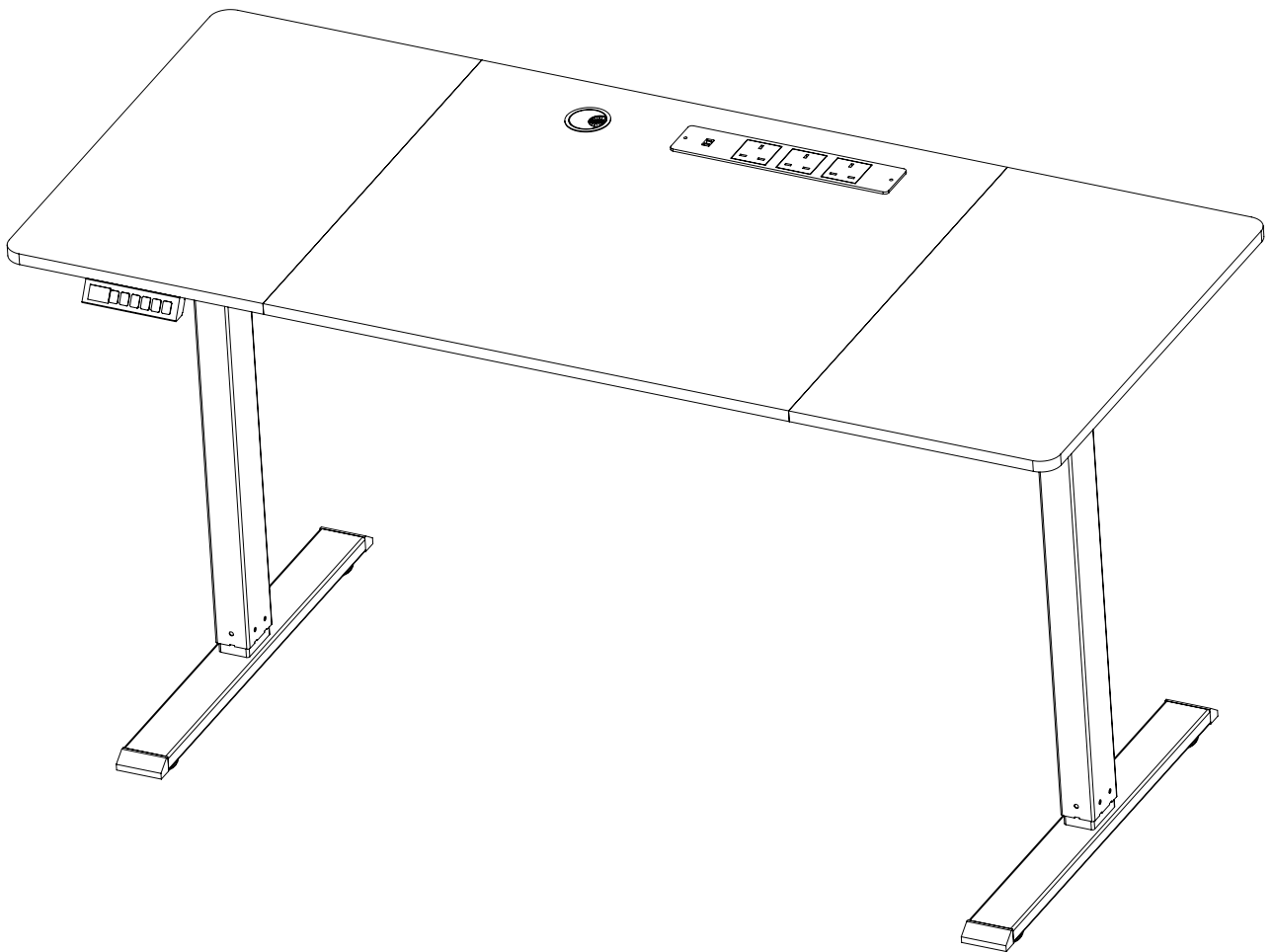

# PACKAGE CONTENTS

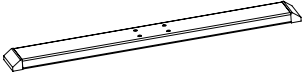

A x 2



B x 1



C x 1



D x 2

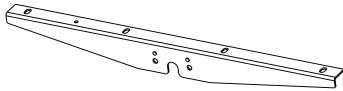

F x 2

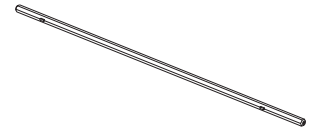

G x 1

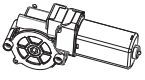

I x 1

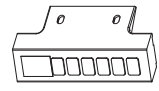

J x 1

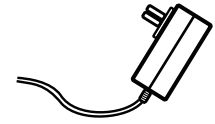

K x 1

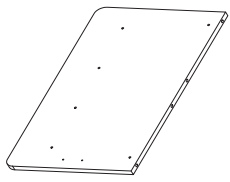

L x 1

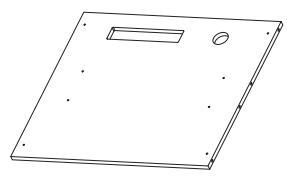

M x 1

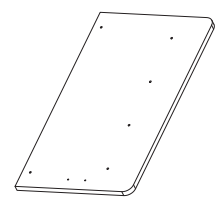

N x 1

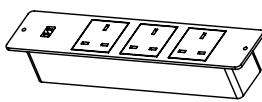

Y x 1

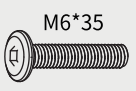

O x 8



P x 32

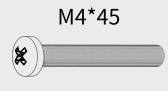

Q x 2



R x 2



S x 1

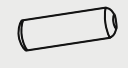

T x 8

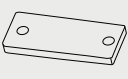

U x 4

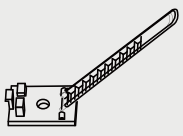

V x 2



W x 4



X x 2



Z x 1

# 1 Foot installation

When the ground is uneven, the foot pad can be rotated to achieve balance.

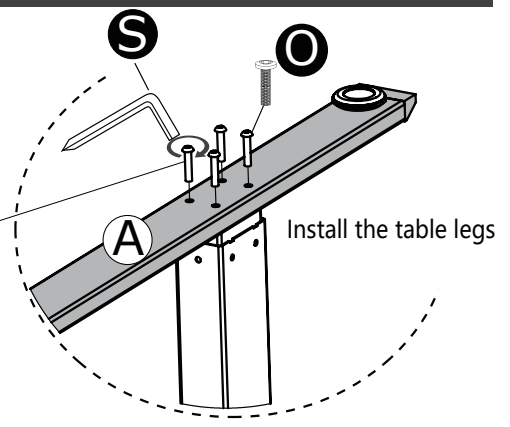
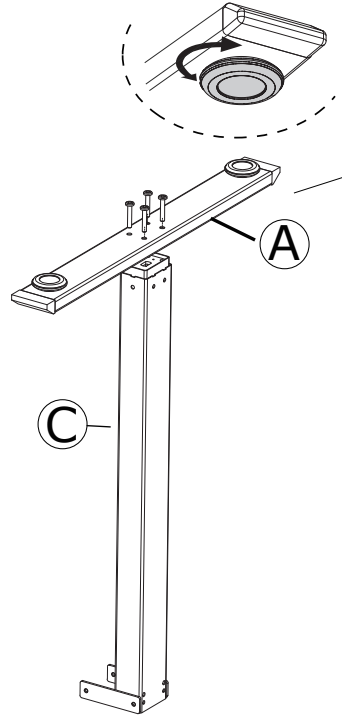
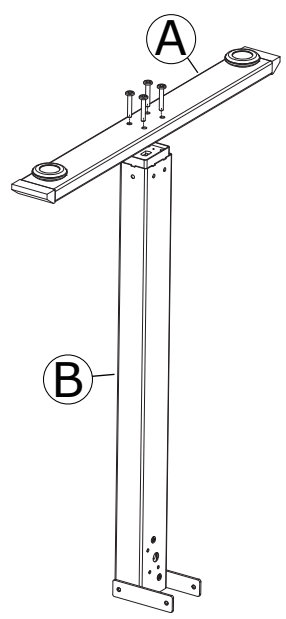

- A x 2
- B x 1
- C x 1

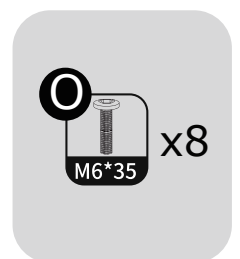

# 2 Install the motor

## Step1

Insert the hex rod into the slot hole of the motor in the direction of the arrow.

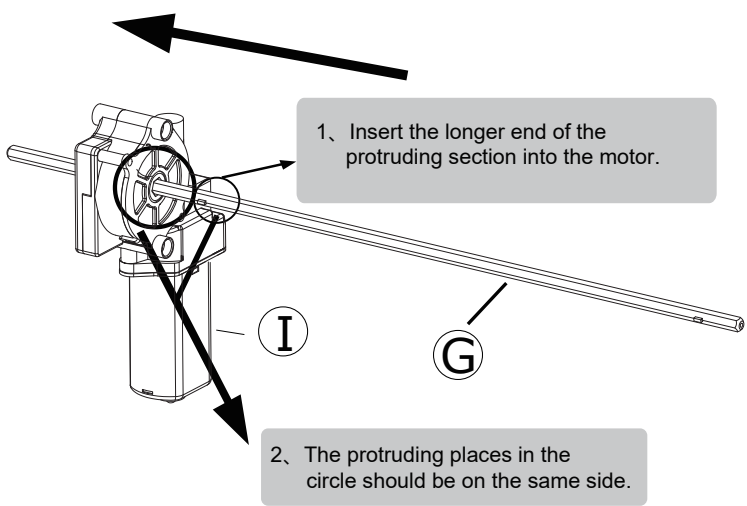

## Step2

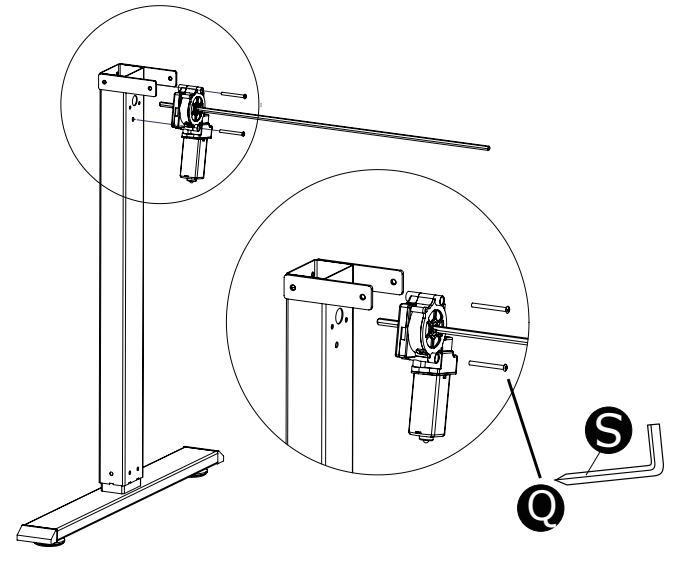

- I x 1
- G x 1

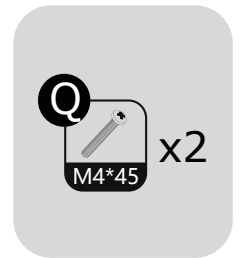

### 3 Drive rod installation-1

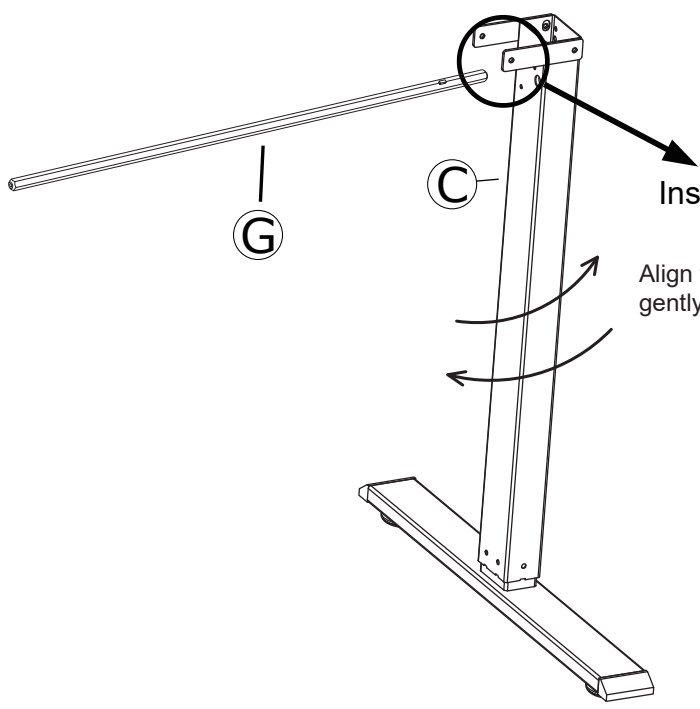

Insert it into the gearbox on the one side

Align the motor rod with leg (C). If the alignment is incorrect, gently move the leg side to side to achieve a secure fit.

G x 1

### 4 Drive rod installation-2

As shown in the following figure

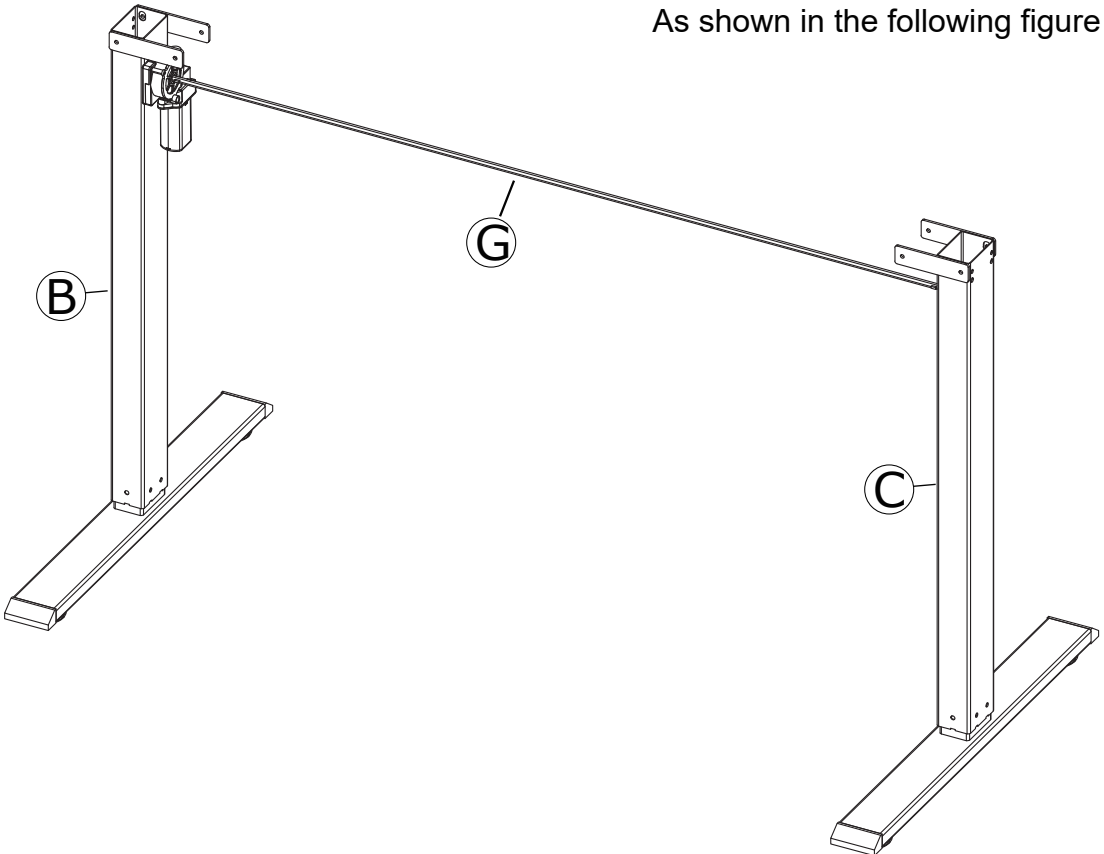

5 Beam installation

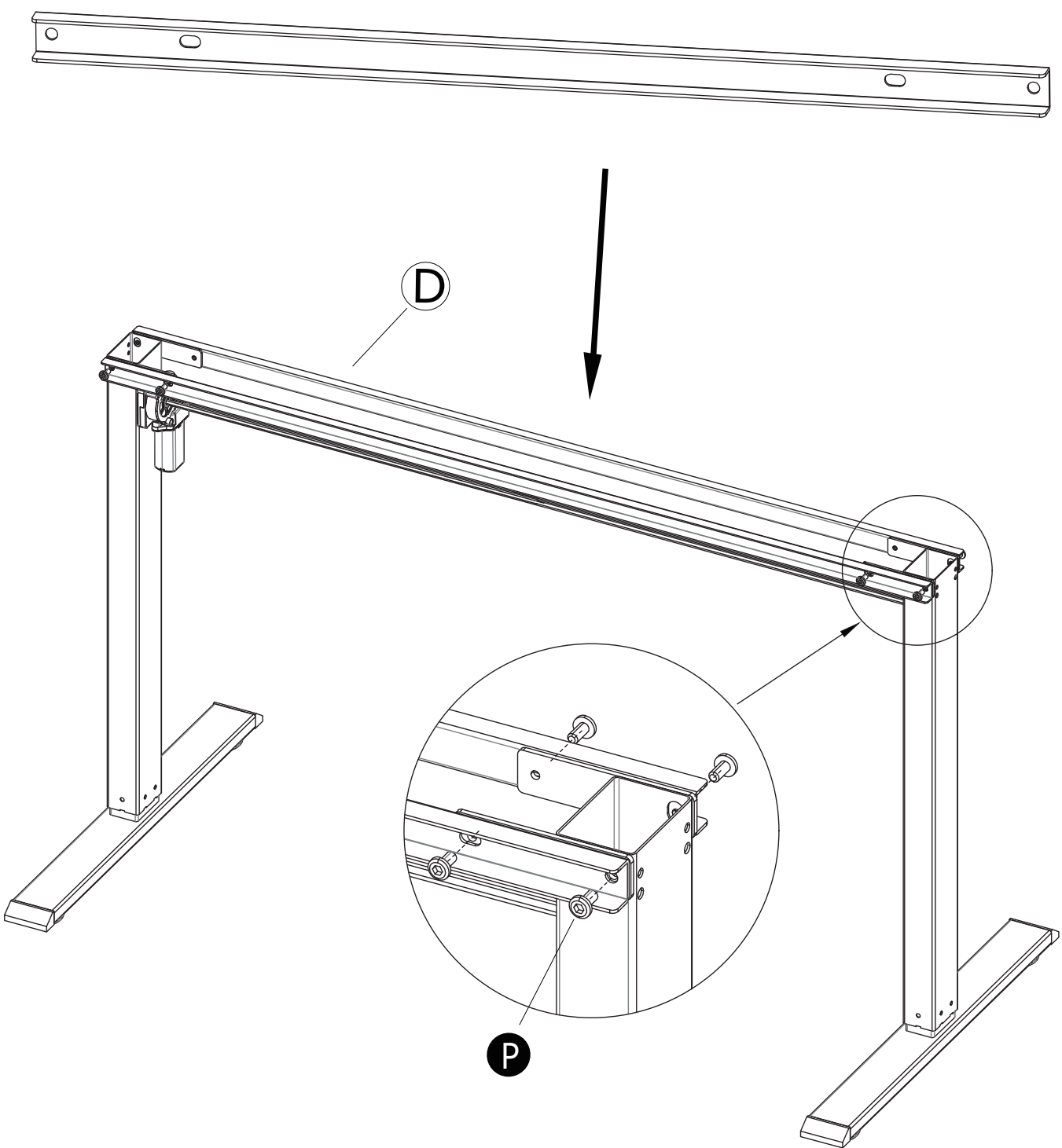

D x 2

P M6\*12 x8

6 Side wing installation

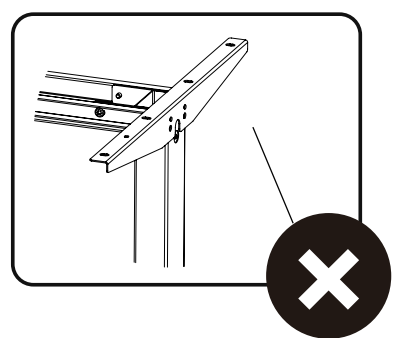
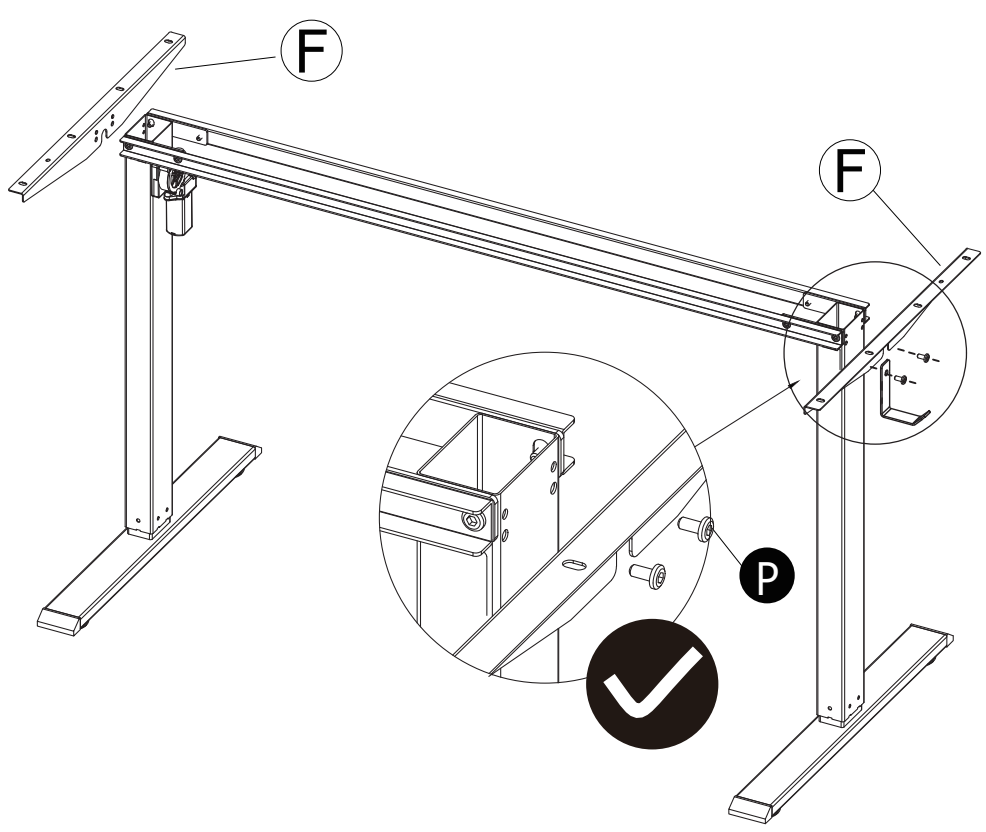

! Incorrect demonstration

F x 2  
Z x 1

P  
M6\*12 x4

7 Panel installation-1

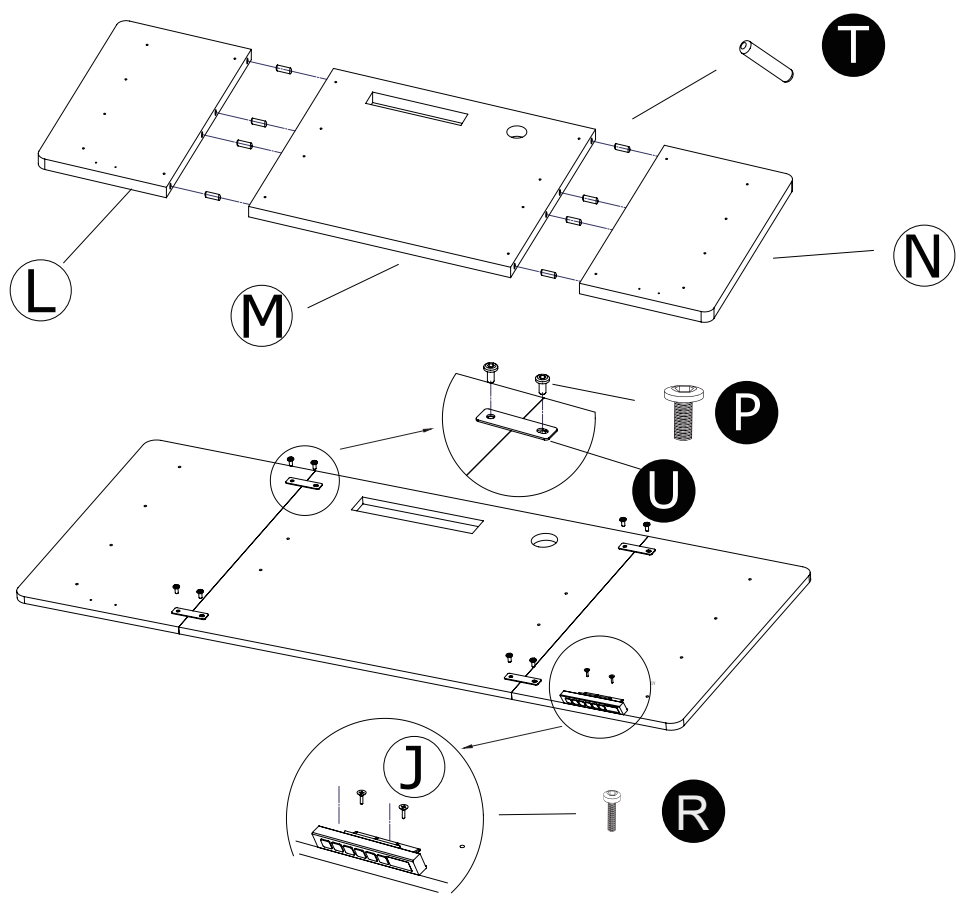

T x8

J x 1  
L x 1  
M x 1  
N x 1

U x4

R x2  
M4\*12

P x8  
M6\*12

8 Panel installation-2

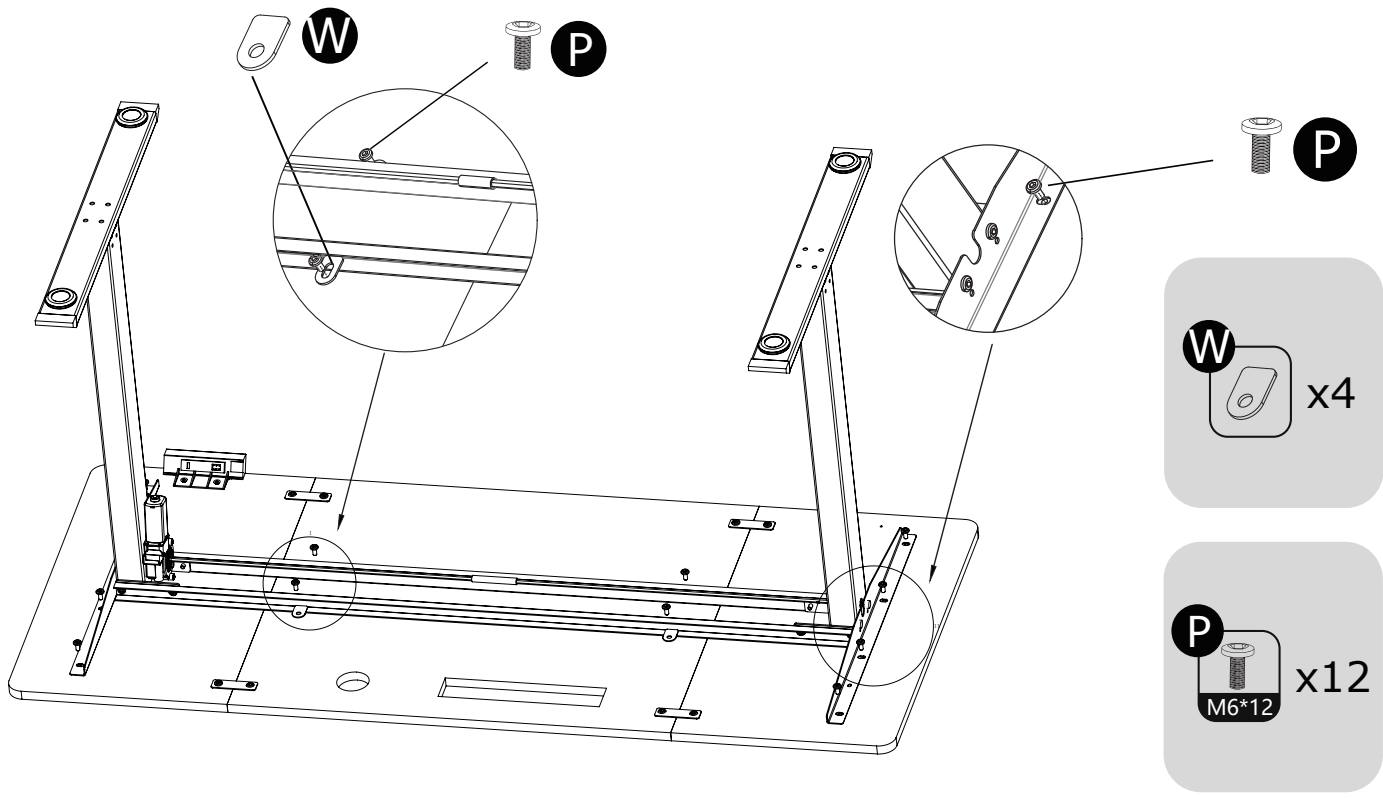

9 Line connection

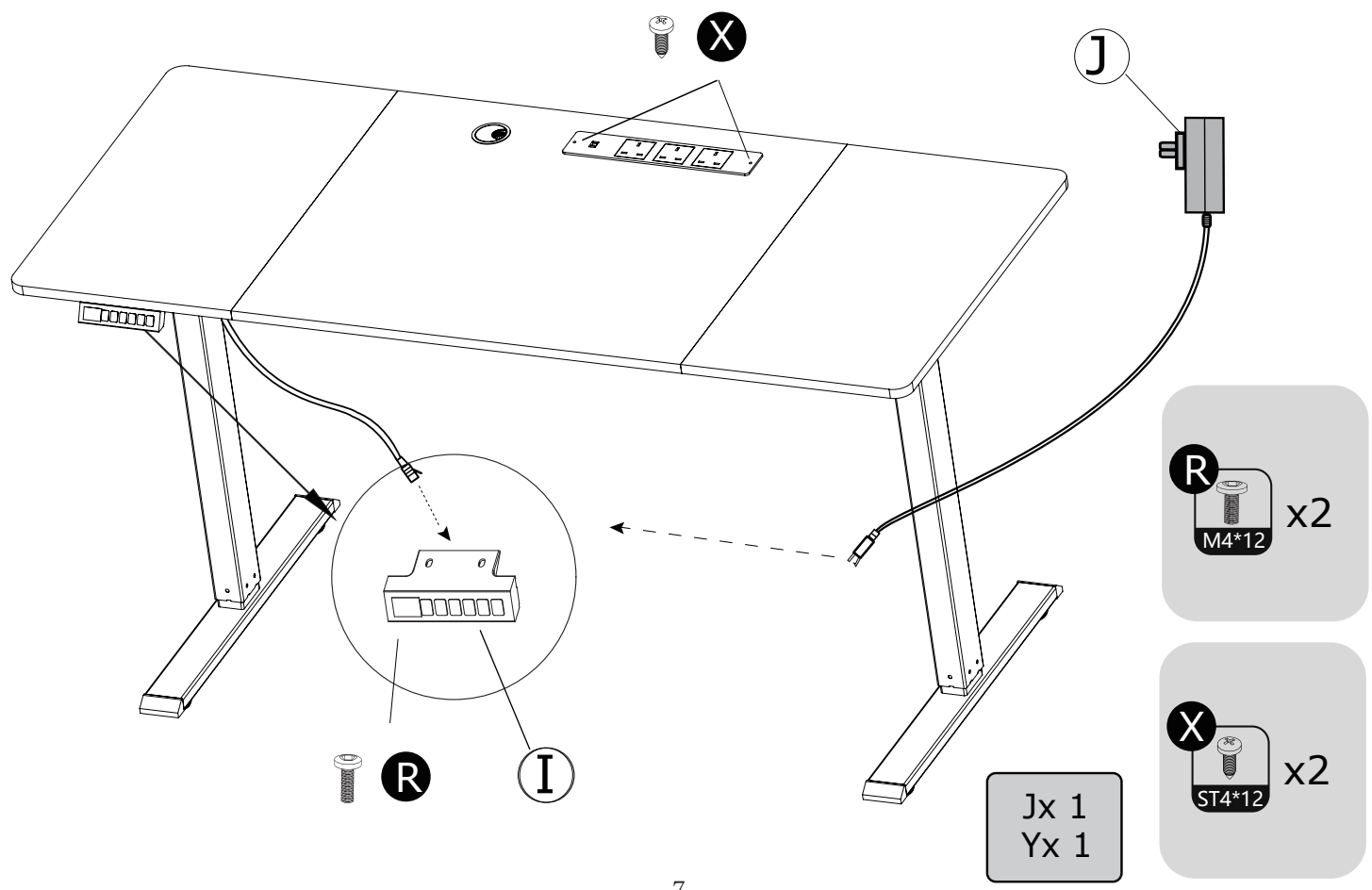

# Height Adjustment Controller Operation

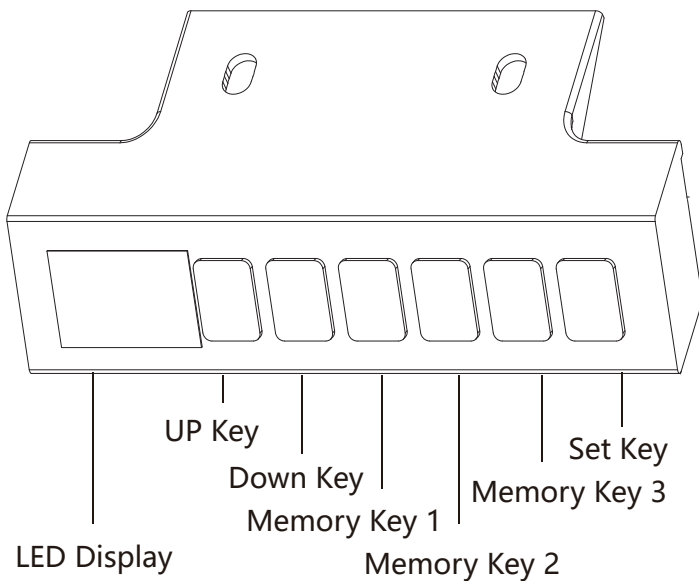

- **LED Display:**  
Press any key once to wake up the LED display.
- **UP Key:** ⤴  
Press and hold the UP key to raise the desk.
- **Down Key:** ⤵  
Press and hold the DOWN key to lower the desk.
- **Memory Key:**  
① ② ③ ④

 You must complete the Initialization Process to reset your desk before using it for the first time.

 When the display shows "E-1" or "RST", it means that a reset operation is in progress, please continue to press and hold the descending key "V" key as required by the instruction manual until the minimum height value appears, and then release the button

## Detailed introduction of key functions

### Reset ⤵

After running to the lowest height position, press and hold for 7 seconds. When the LED screen "RST" and "E-1" flash alternately, release the "V" key, and press and hold the key again. After the desktop runs down to the lowest mechanical zero point, go back 5mm, the LED screen displays the lowest height value, and the reset is completed.

### Set memory height ④ + ①/②/③

Press the S key once, and the height value will start flashing. At this time, press the 1, 2, and 3 keys to save the current height to the corresponding position.

### Execute memory height ① ② ③

In normal state, press the number key to call up its corresponding height, and the lifting table will automatically run to the corresponding position.

### Lock key ④

Press and hold the S key for 3 seconds. When the LED screen displays "SET", learn to open the S key. Press the number key 3 to enter the lock screen state. At this time, the LED screen flashes and displays "OFF".When the screen is locked, press and hold the S key for 3s, and the LED screen displays the height value. At this time, release the S key to complete the unlocking.

### Restore factory settings ④

Press and hold the S key for 9 seconds, release the S key when the LED screen displays "FAC", and operate the S key again to restore the factory settings.

Error Code Instructions		
Error Code	Reason	Solution
Err	Err is displayed when the communication line sequence between the manual controller and the control box is wrong	/
E-1	When the system does not save the current position, the LED screen flashes alternately to display "E-1"	Reset by pressing the long key until the LED screen displays the minimum height and the alarm is released
E-2	When the motor is locked, the LED displays "E-2"	/
E-5	When the motor appears: the connecting line is disconnected /loosened, the LED screen flashes alternately to display "E-5"	Check the connection lines between all motors and the controller to ensure that they are firm, and then reset by long pressing the down key until the LED screen displays the minimum height, and remove the alarm
ovr	When the load exceeds the set value, the LED screen flashes to display ovr. At this time, it is necessary to remove the weight of the desktop and power on the controller after powering off. This alarm can be relieved	<ol style="list-style-type: none"> <li>1. Normal load shall be controlled below 120KG</li> <li>2. When the current exceeds 4A, the overload protection function will be triggered</li> </ol>
hot	When the internal temperature of the controller exceeds 60±5 degrees, the LED displays "hot"	/
voL	When the input voltage of the controller exceeds 34V, the LED displays "voL"	<ol style="list-style-type: none"> <li>1. When the voltage exceeds 32V, the controller is powered off and the LED screen is black;</li> <li>2. When the voltage drops to 32V, the system will automatically reply and LED will display the real-time height</li> </ol>
hot	After the motor runs continuously for 5 min, the LED screen displays hot, and it can work normally after waiting for 10min	<ol style="list-style-type: none"> <li>1. Uninterrupted operation means that the operation interval is within 3s</li> <li>2. This alarm can also be removed when the control system is powered on again</li> </ol>
E-3	During the operation, when suddenly blocked, the LED screen flashes "E-3", stops the action and runs 30mm in the opposite direction, then the LED screen displays the real-time height	It shall be ensured that the table will not vibrate significantly, bump into obstacles or tilt during operation

# VERPACKUNGSGEHÄLT

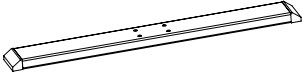

A x 2



B x 1



C x 1



D x 2

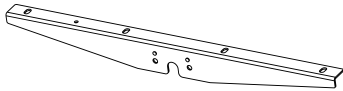

F x 2

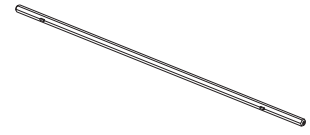

G x 1

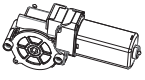

I x 1

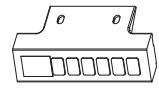

J x 1

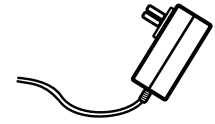

K x 1

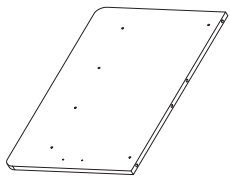

L x 1

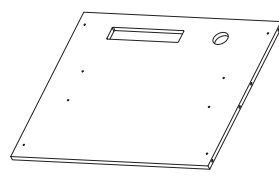

M x 1

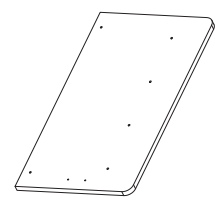

N x 1

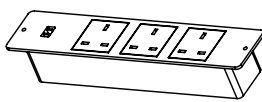

Y x 1

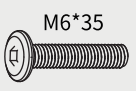

O x 8



P x 32

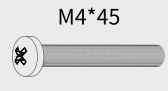

Q x 2



R x 2



S x 1

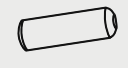

T x 8

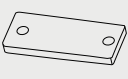

U x 4

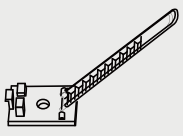

V x 2



W x 4



X x 2



Z x 1

## 1 Fußinstallation

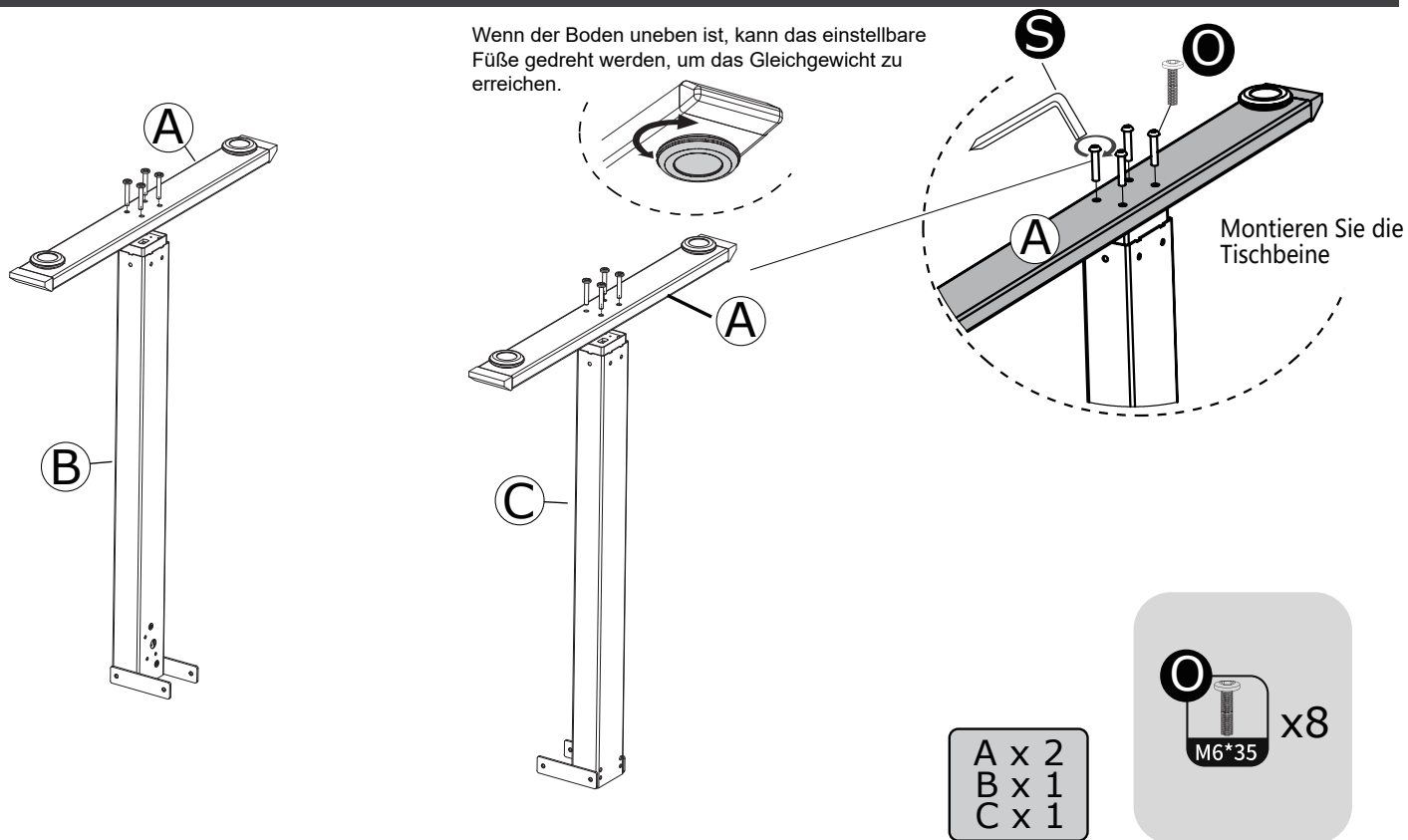

## 2 Installieren Sie den Motor

### Schritt 1

Führen Sie die Sechskantstange in das Schlitzloch des Motors in Pfeilrichtung ein.

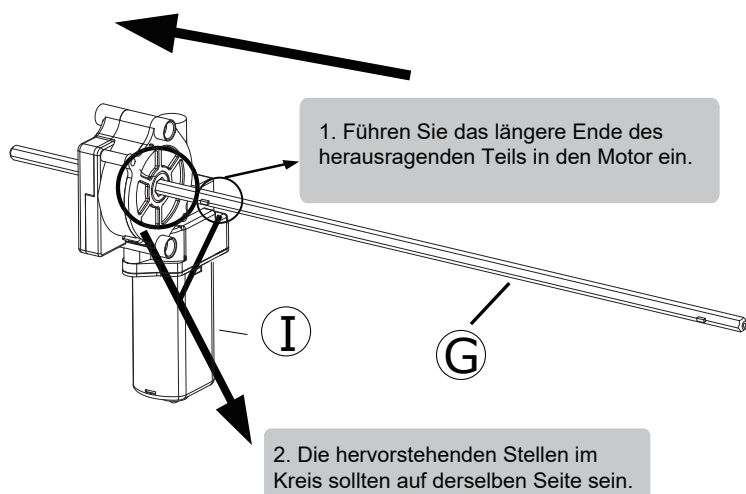

### Schritt 2

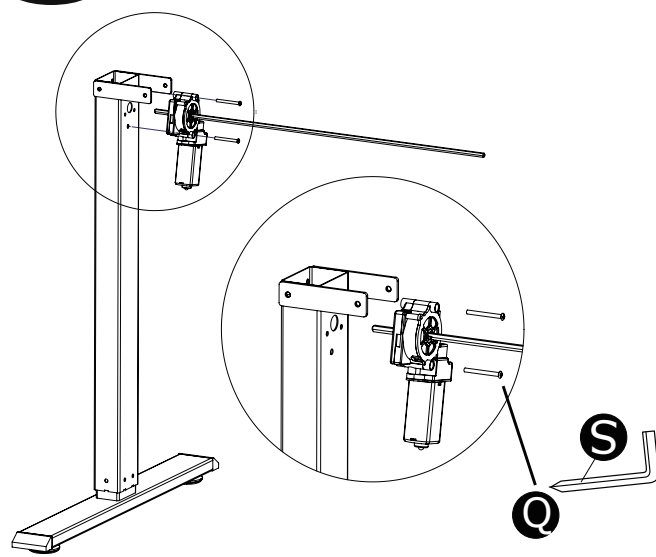

I	x 1
G	x 1

Q  
M4\*45 x2

### 3 Antriebsgestängeinstallation-1

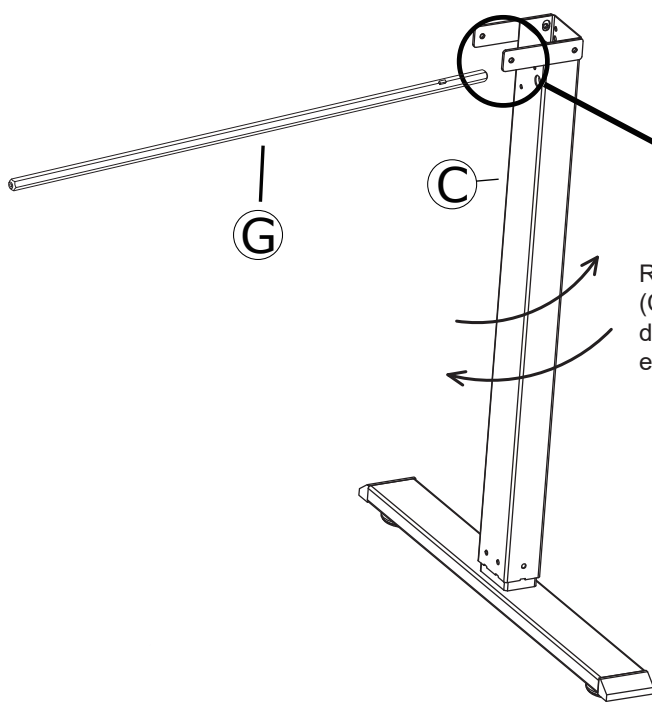

Setzen Sie es in das Getriebe auf einer Seite ein.

Richten Sie die Motorstange mit Bein (C) aus. Wenn die Ausrichtung nicht korrekt ist, bewegen Sie das Bein vorsichtig hin und her, um einen sicheren Sitz zu erreichen.

G x 1

### 4 Antriebsgestängeinstallation-2

Wie in der folgenden Abbildung gezeigt

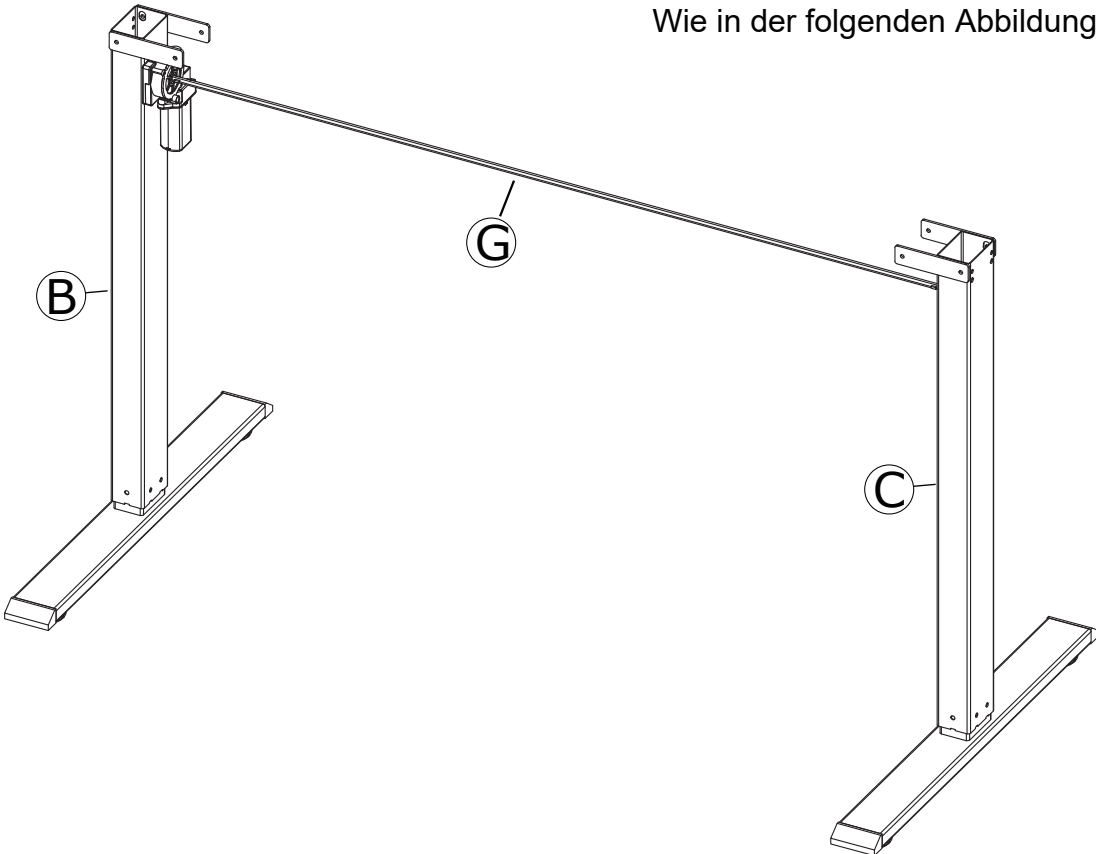

# 5 Balkeninstallation

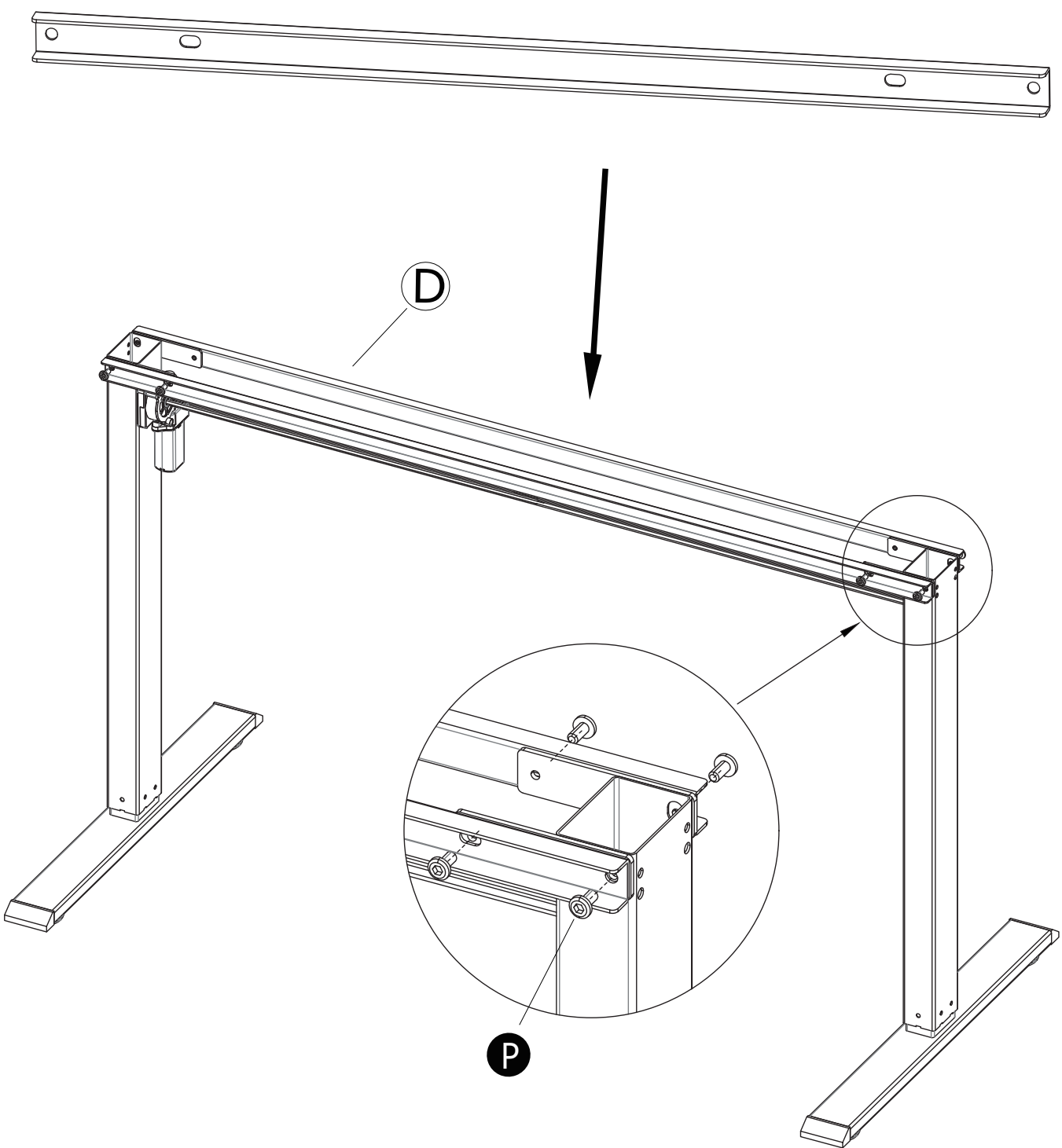

D x 2

P M6\*12 x8

# 6 Seitliche Flügelnstallation

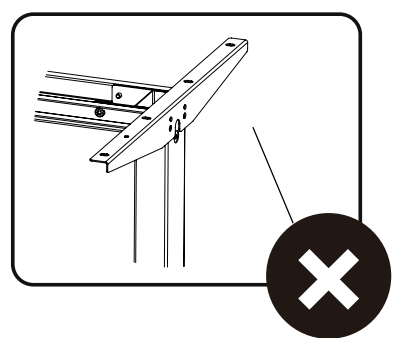
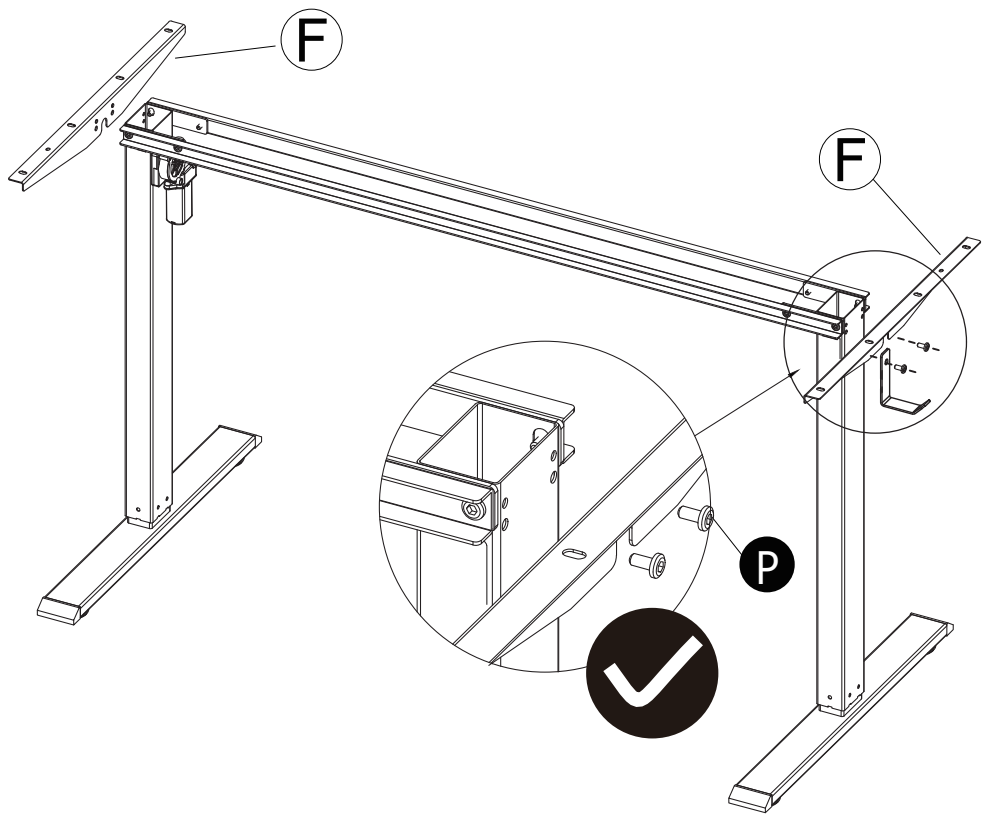

! Fehlerhafte Demonstration

F x 2  
Z x 1

P  
M6\*12 x4

# 7 Platteninstallation-1

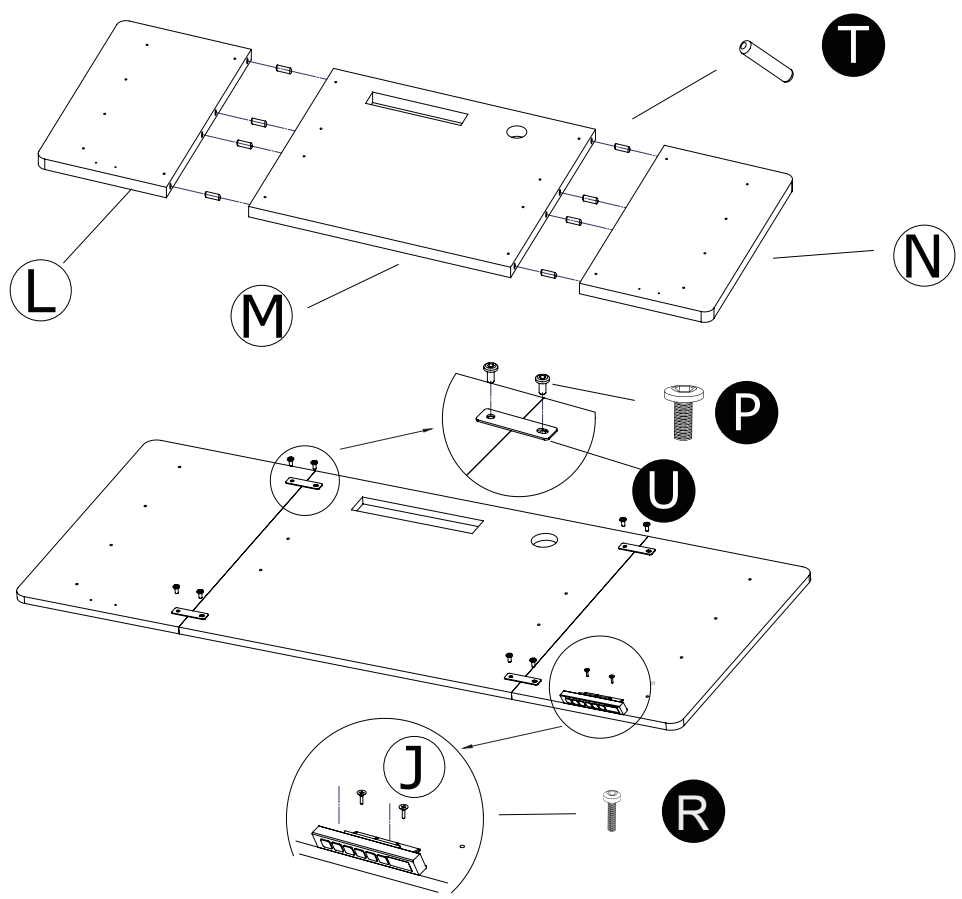

T x8

J x 1  
L x 1  
M x 1  
N x 1

U x4

R x2  
M4\*12

P x8  
M6\*12

## 8 Platteninstallation-2

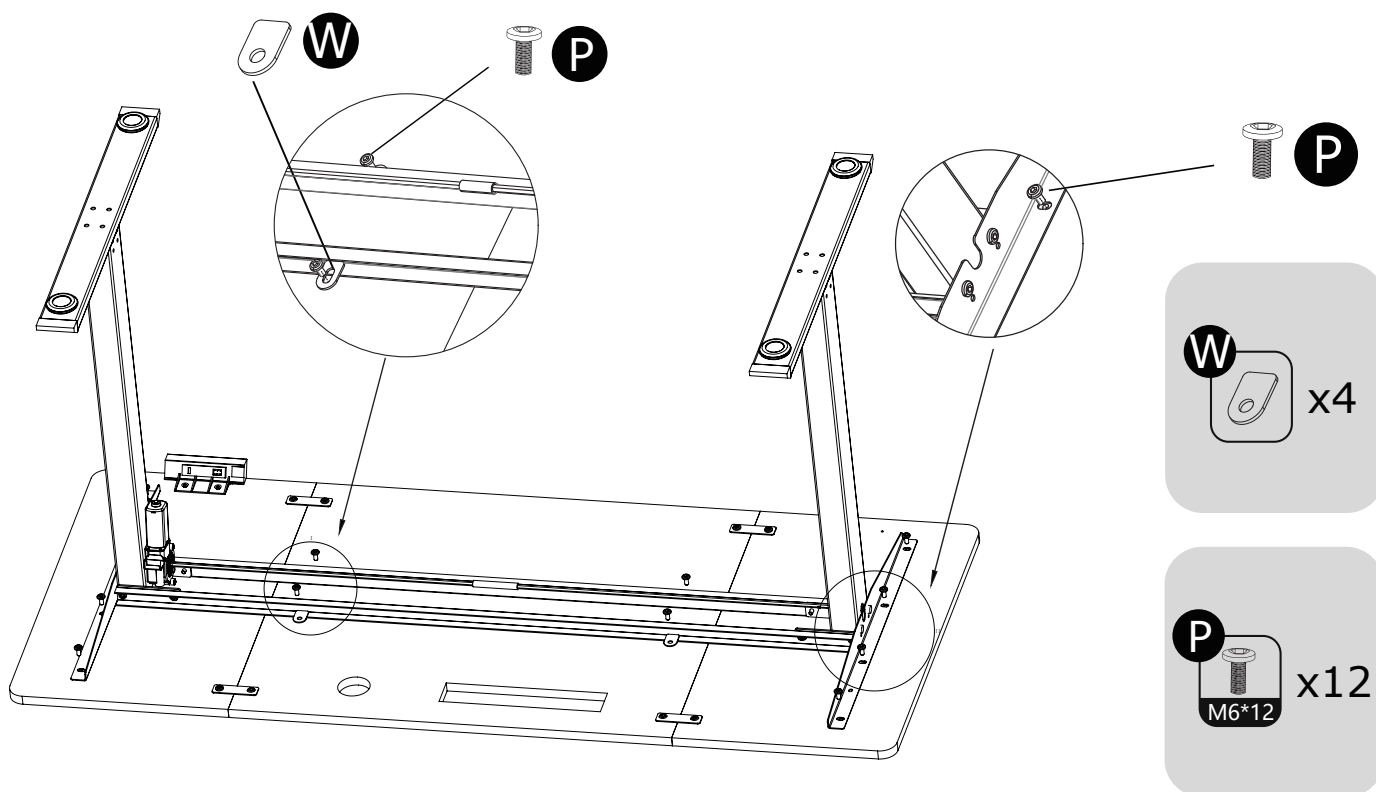

## 9 Leitungsanschluss

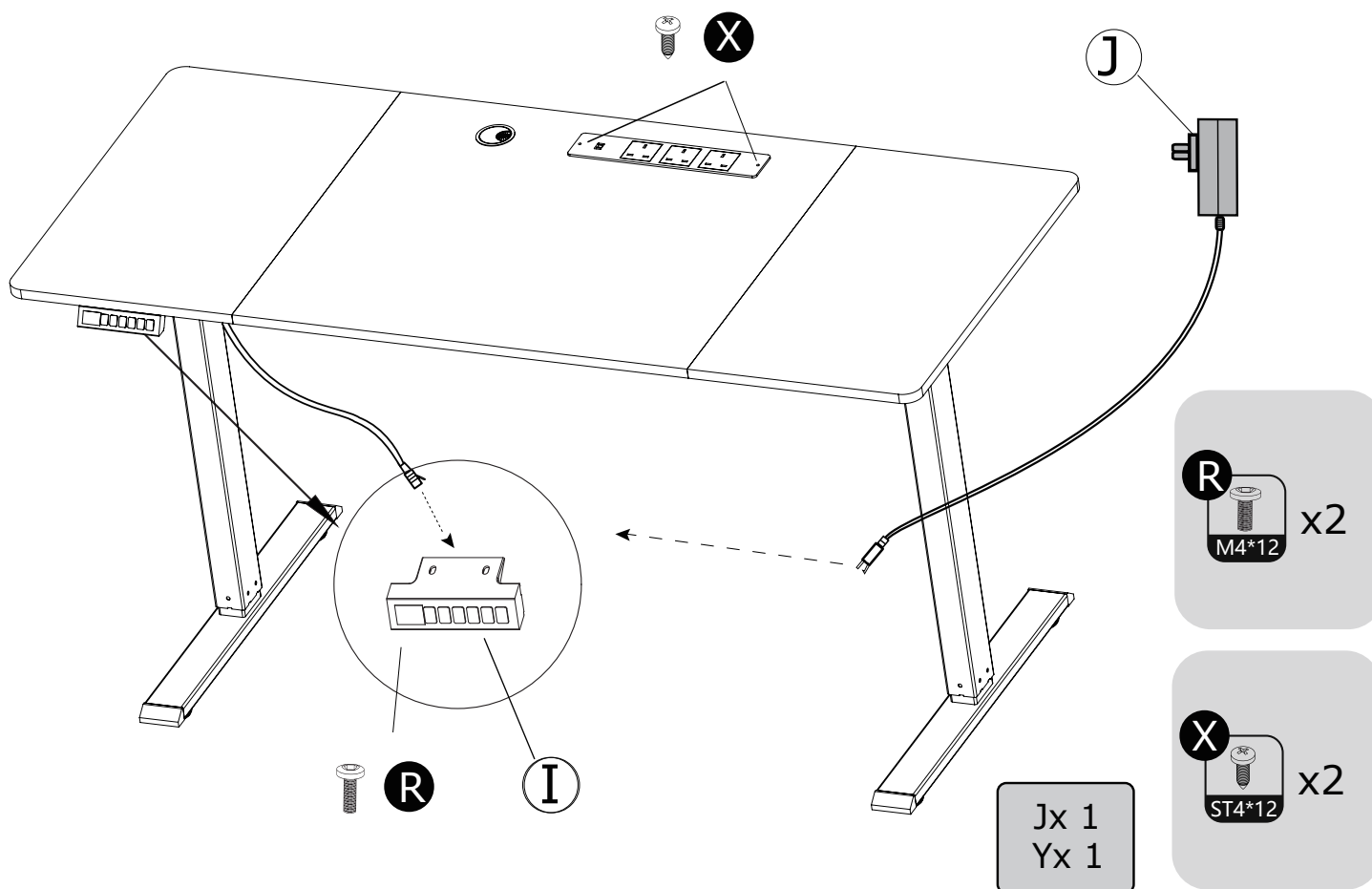

# Höhenverstellungs-Controller-Bedienung

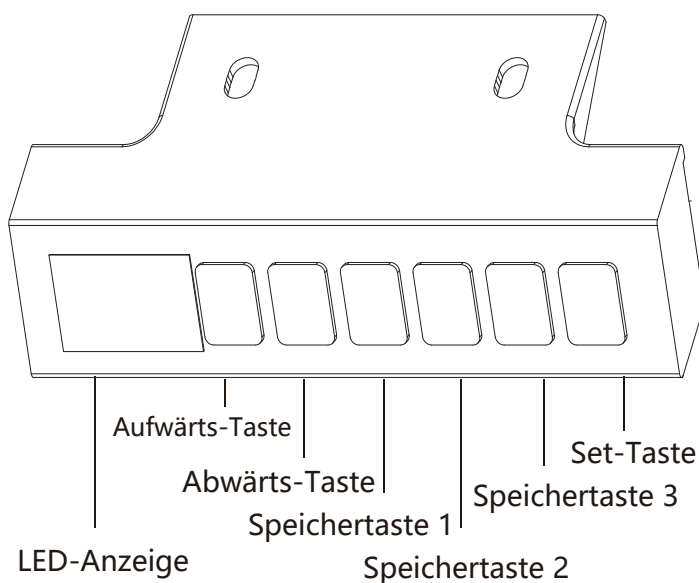

## • LED-Anzeige:

Drücken Sie einmal eine beliebige Taste, um die LED-Anzeige zu aktivieren.

## • Aufwärts-Taste:

Halten Sie die Aufwärts-Taste gedrückt, um den Schreibtisch anzuheben.

## • Abwärts-Taste:

Halten Sie die Abwärts-Taste gedrückt, um den Schreibtisch abzusenken.

## • Speichertaste:



Sie müssen den Initialisierungsprozess abschließen, um Ihren Schreibtisch vor der ersten Verwendung zurückzusetzen.



Wenn auf dem Display "E-1" oder "RST" angezeigt wird, bedeutet dies, dass ein Rücksetzvorgang im Gange ist. Bitte halten Sie die Abwärts-Taste "V" wie in der Bedienungsanleitung beschrieben gedrückt, bis der Mindesthöhenwert angezeigt wird, und lassen Sie dann die Taste los.

## Detaillierte Einführung der Tastenfunktionen

### Zurücksetzen

Nachdem die niedrigste Höhe erreicht wurde, drücken und halten Sie die Taste 7 Sekunden lang. Wenn das LED-Display "RST" und "E-1" abwechselnd blinkt, lassen Sie die "V"-Taste los und drücken Sie die Taste erneut. Nachdem der Schreibtisch auf den niedrigsten mechanischen Nullpunkt abgesenkt wurde, gehen Sie 5 mm zurück. Das LED-Display zeigt den niedrigsten Höhenwert an und der Reset ist abgeschlossen.

### Speicherhöhe einstellen + / /

Drücken Sie einmal die S-Taste, und der Höhenwert beginnt zu blinken. Drücken Sie nun die Tasten 1, 2 und 3, um die aktuelle Höhe an der entsprechenden Position zu speichern.

### Speicherhöhe ausführen

Im Normalzustand drücken Sie die Zahlentaste, um die entsprechende Höhe abzurufen, und der Hebetisch fährt automatisch in die entsprechende Position.

### Sperrtaste

Drücken und halten Sie die S-Taste 3 Sekunden lang. Wenn das LED-Display "SET" anzeigt, lernen Sie, die S-Taste zu entsperren. Drücken Sie die Zahlentaste 3, um den Sperrbildschirmmodus zu aktivieren. In diesem Moment blinkt die LED-Anzeige und zeigt "OFF" an. Wenn der Bildschirm gesperrt ist, drücken und halten Sie die S-Taste 3 Sekunden lang und die LED-Anzeige zeigt den Höhenwert an. Lassen Sie dann die S-Taste los, um das Entsperren abzuschließen.

### Werkseinstellungen wiederherstellen

Drücken und halten Sie die S-Taste 9 Sekunden lang. Wenn das LED-Display "FAC" anzeigt, lassen Sie die S-Taste los und drücken Sie die S-Taste erneut, um die Werkseinstellungen wiederherzustellen.

## Fehlercode-Anweisungen

Fehlercode	Grund	Lösung
Err	Err wird angezeigt, wenn die Kommunikationsleitung zwischen dem Handcontroller und der Steuerbox falsch ist.	/
E-1	Wenn das System die aktuelle Position nicht speichert, blinkt das LED-Display abwechselnd "E-1".	Zurücksetzen durch Drücken und Halten der langen Taste, bis das LED-Display die Mindesthöhe anzeigt und der Alarm aufgehoben wird.
E-2	Wenn der Motor blockiert ist, zeigt das LED-Display "E-2" an.	/
E-5	Wenn der Motor folgendes anzeigt: Die Verbindungsleitung ist unterbrochen/gelockert, blinkt das LED-Display abwechselnd "E-5".	Überprüfen Sie die Verbindungsleitungen zwischen allen Motoren und dem Controller, um sicherzustellen, dass sie fest sitzen, und setzen Sie dann durch langes Drücken der Abwärts-Taste zurück, bis das LED-Display die Mindesthöhe anzeigt, und heben Sie den Alarm auf.
ovr	Wenn die Last den eingestellten Wert überschreitet, blinkt das LED-Display und zeigt "ovr" an. In diesem Fall muss das Gewicht der Tischplatte entfernt und der Controller nach dem Ausschalten wieder eingeschaltet werden, um den Alarm zu beheben.	<ol style="list-style-type: none"> <li>1. Die normale Last sollte unter 120KG liegen.</li> <li>2. Wenn der Strom 4A überschreitet, wird der Überlastschutz aktiviert.</li> </ol>
hot	Wenn die Innentemperatur des Controllers $60\pm 5$ Grad überschreitet, zeigt das LED-Display "hot" an.	/
voL	Wenn die Eingangsspannung des Controllers 34V überschreitet, zeigt das LED-Display "voL" an.	<ol style="list-style-type: none"> <li>1. Wenn die Spannung 32V überschreitet, wird der Controller ausgeschaltet und das LED-Display ist schwarz;</li> <li>2. Wenn die Spannung auf 32V fällt, wird das System automatisch wieder aktiviert und das LED-Display zeigt die Echtzeithöhe an.</li> </ol>
hot	Nachdem der Motor 5 Minuten lang ununterbrochen gelaufen ist, zeigt das LED-Display "hot" an, und nach 10 Minuten Wartezeit funktioniert er wieder normal.	<ol style="list-style-type: none"> <li>1. Ununterbrochener Betrieb bedeutet, dass das Betriebsintervall weniger als 3 Sekunden beträgt.</li> <li>2. Dieser Alarm kann auch entfernt werden, wenn das Steuerungssystem wieder eingeschaltet wird.</li> </ol>
E-3	Während des Betriebs, wenn plötzlich eine Blockade auftritt, blinkt das LED-Display "E-3", stoppt die Aktion und fährt 30 mm in die entgegengesetzte Richtung, dann zeigt das LED-Display die Echtzeithöhe an.	Es muss sichergestellt werden, dass der Tisch während des Betriebs nicht stark vibriert, auf Hindernisse trifft oder sich neigt.

# CONTENUTO DEL PACCO

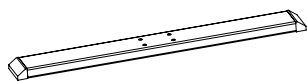

A x 2



B x 1



C x 1



D x 2

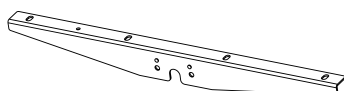

F x 2

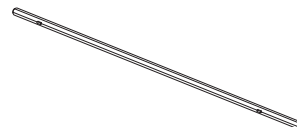

G x 1

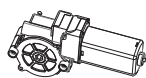

I x 1

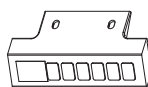

J x 1

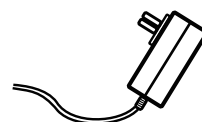

K x 1

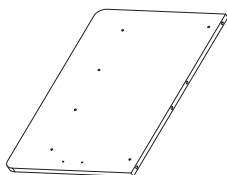

L x 1

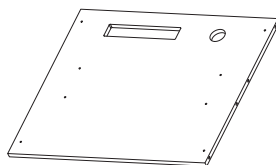

M x 1

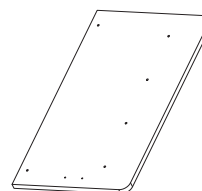

N x 1

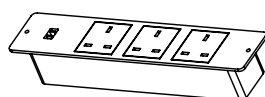

Y x 1

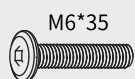

M6\*35

O x 8



M6\*12

P x 32



M4\*45

Q x 2



M4\*12

R x 2



+

S x 1



T x 8



U x 4

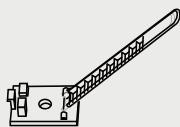

V x 2



W x 4



ST4\*12

X x 2

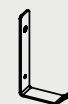

Z x 1

## 1 Installazione delle gambe

Quando il pavimento è irregolare, il piedino può essere ruotato per raggiungere l'equilibrio.

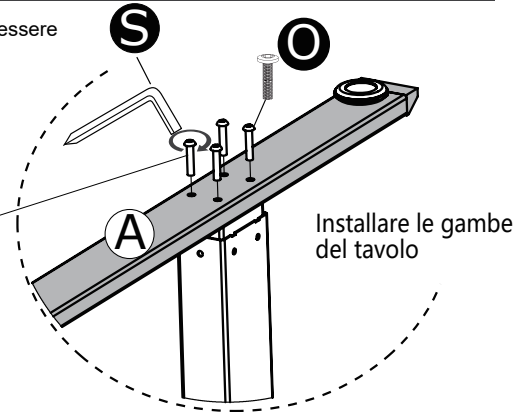
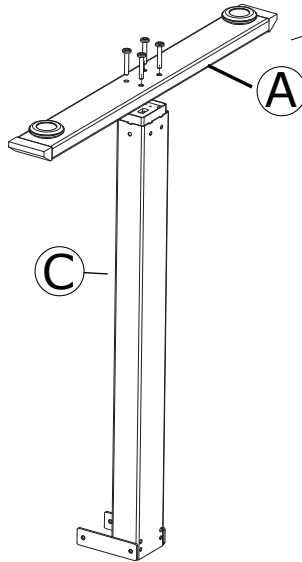
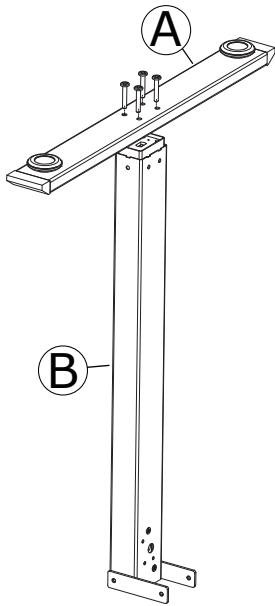

A x 2  
B x 1  
C x 1

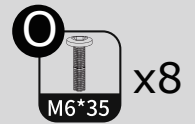

## 2 Installare il motore

**Passo 1**

Inserire il tubo esagonale nel foro della fessura del motore nella direzione della freccia.

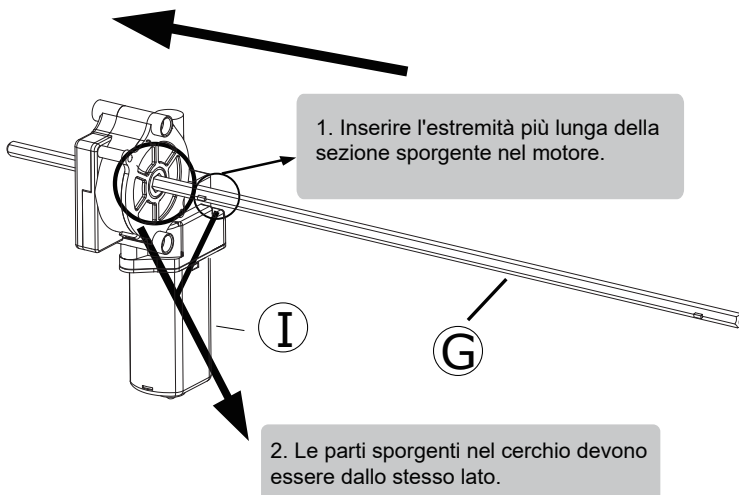

**Passo 2**

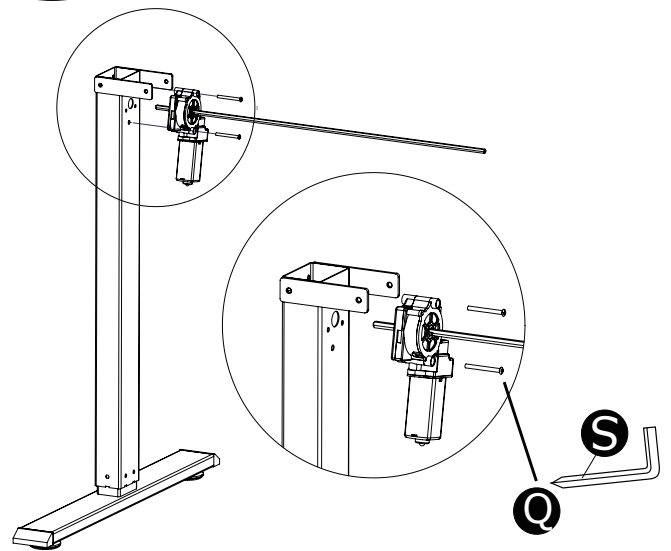

I x 1  
G x 1

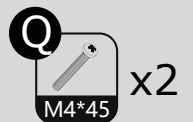

### 3 Installazione del bastone di azionamento-1

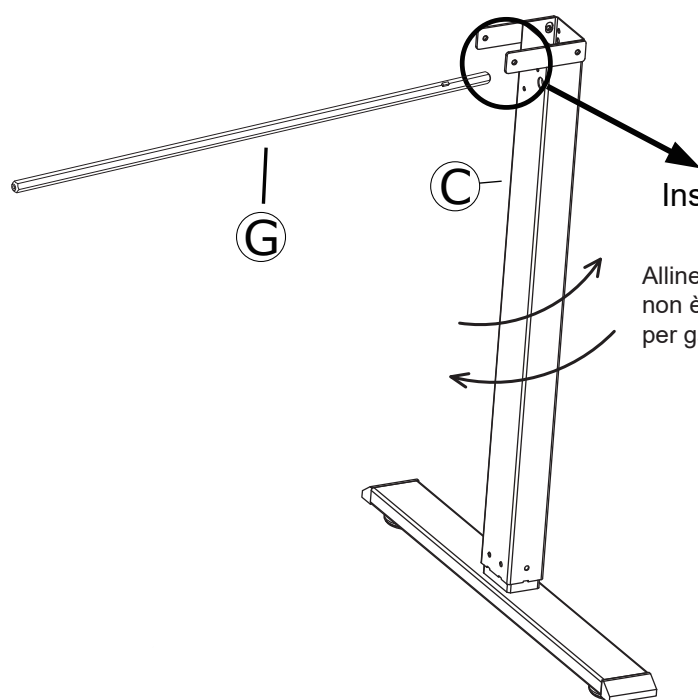

Inserirlo nel riduttore da un lato

Allineare il bastone del motore con la gamba (C). Se l'allineamento non è corretto, muovere delicatamente la gamba da un lato all'altro per garantire una buona aderenza.

G x 1

### 4 Installazione del bastone diazionamento-2

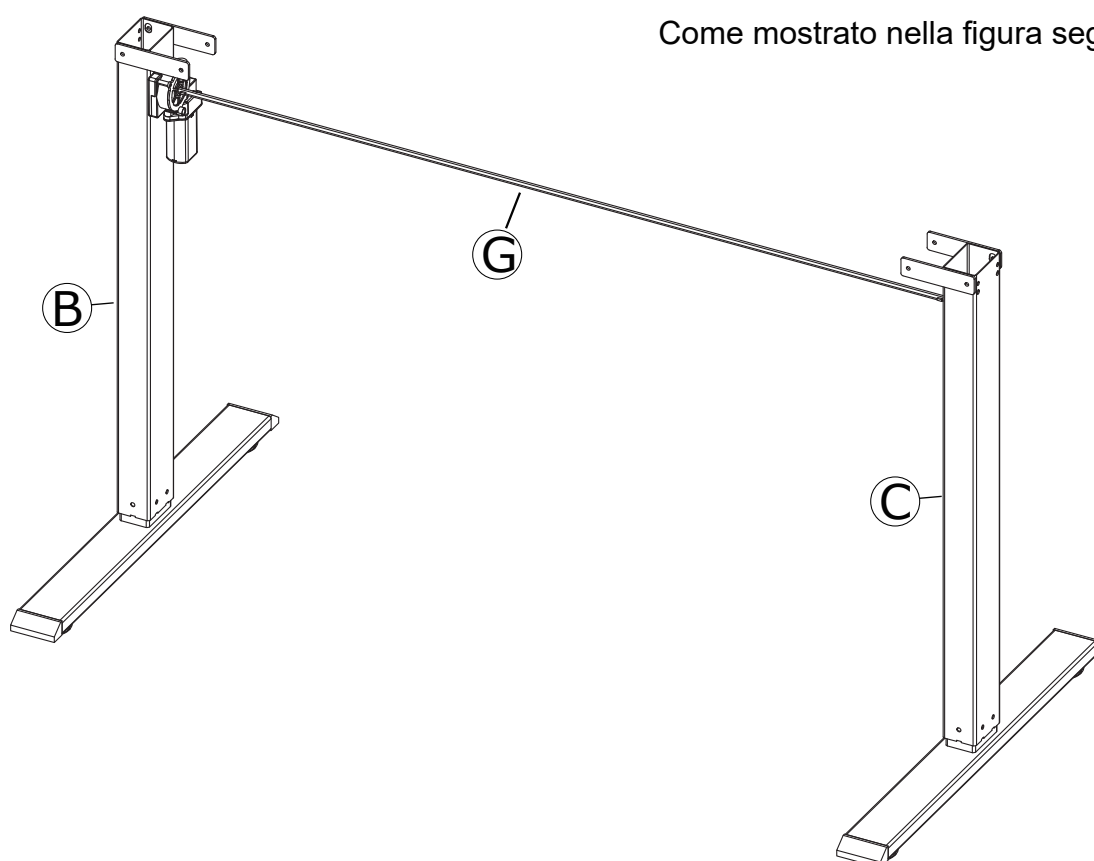

Come mostrato nella figura seguente

5 Installazione del fascio

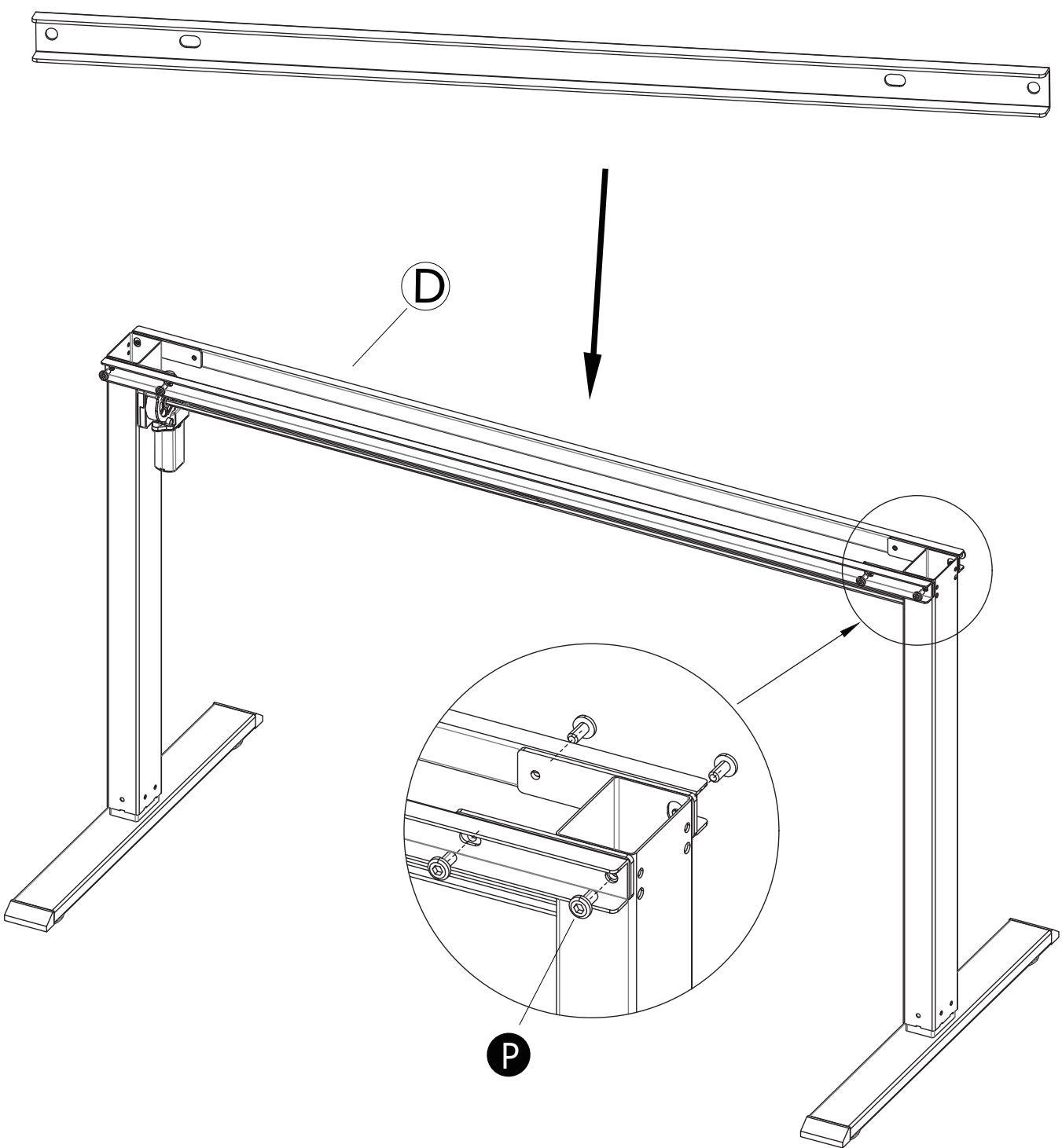

D x 2

P  
M6\*12 x8

## 6 Installazione delle ali laterali

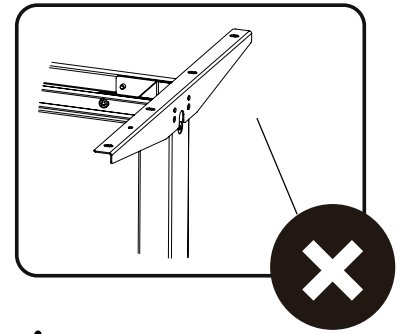
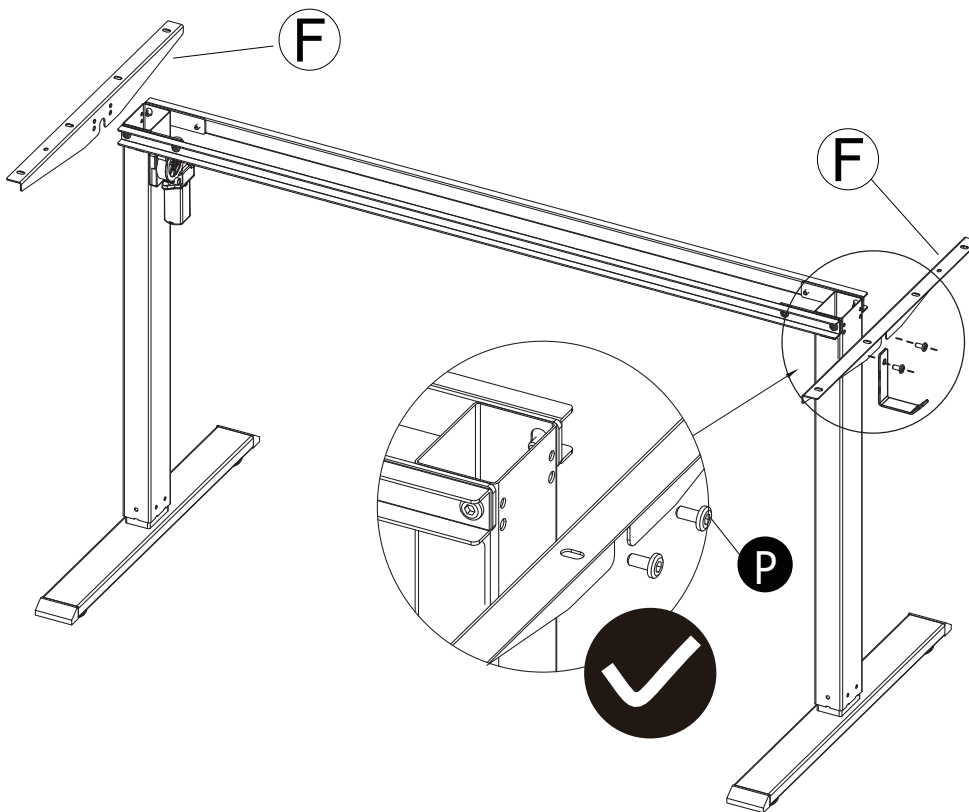

**!** Dimostrazione errata

F x 2  
Z x 1

P  
M6\*12 x4

## 7 Installazione del pannello-1

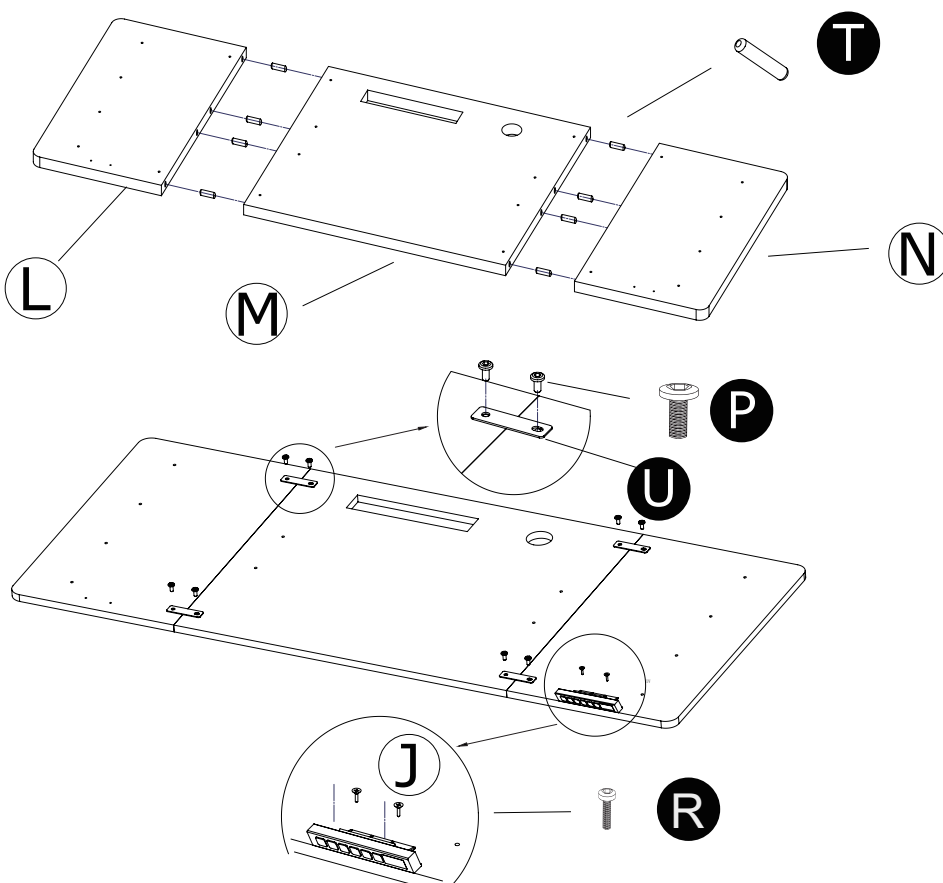

T x8

U x4

J x 1  
L x 1  
M x 1  
N x 1

R x2  
M4\*12

P x8  
M6\*12

## 8 Installazione del pannello-2

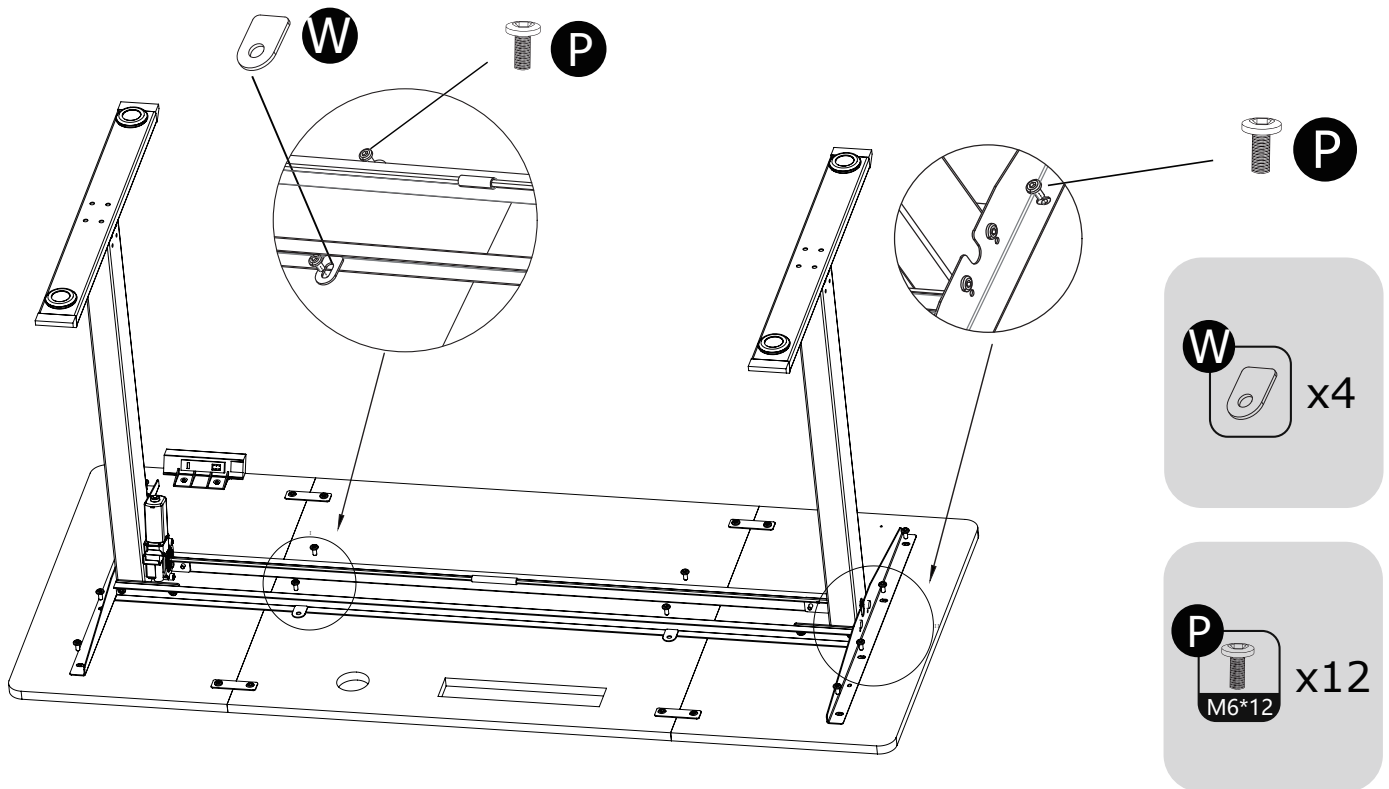

## 9 Collegamento dei cavi

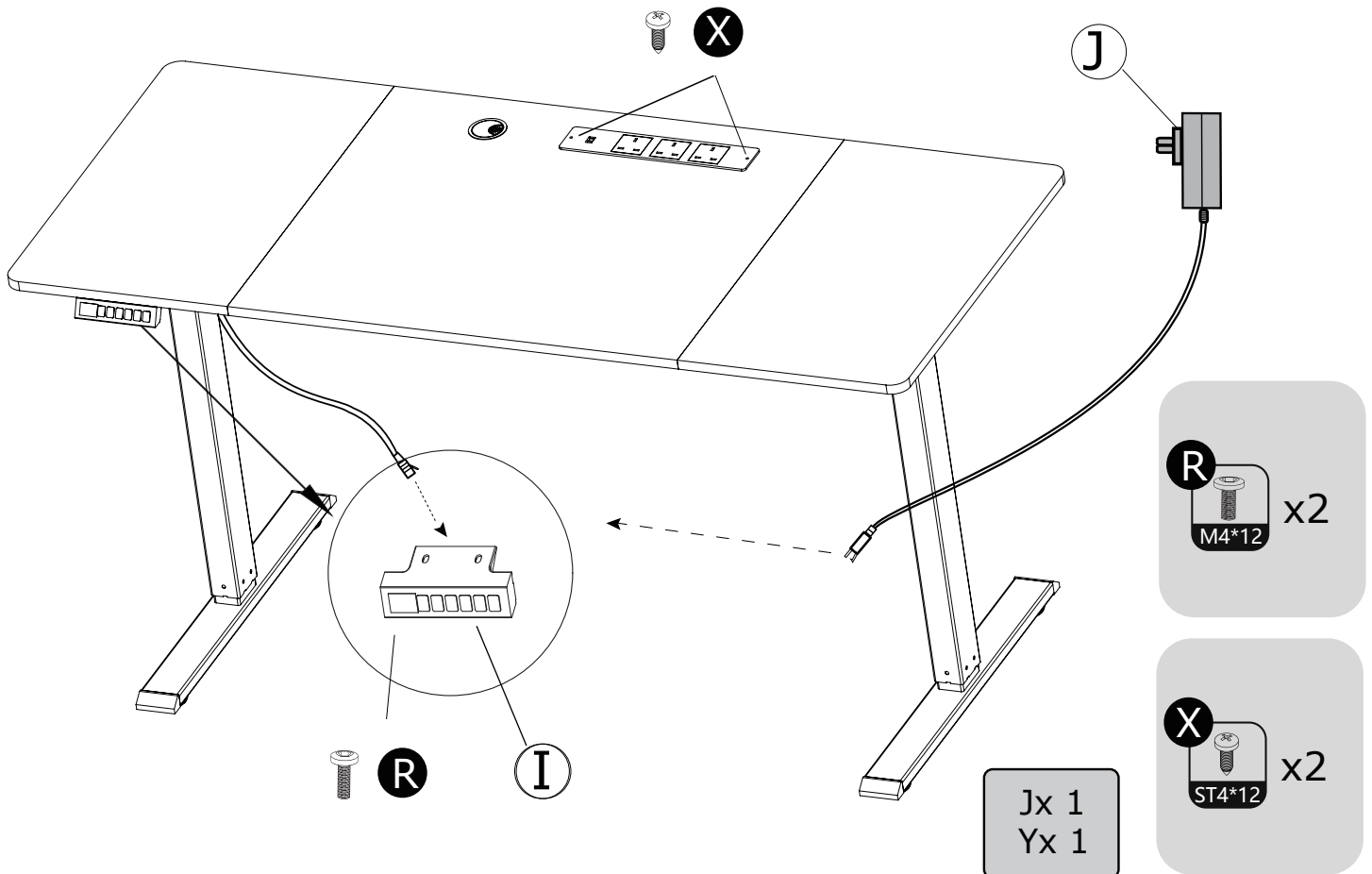

## Funzionamento del controller diregolazione dell'altezza

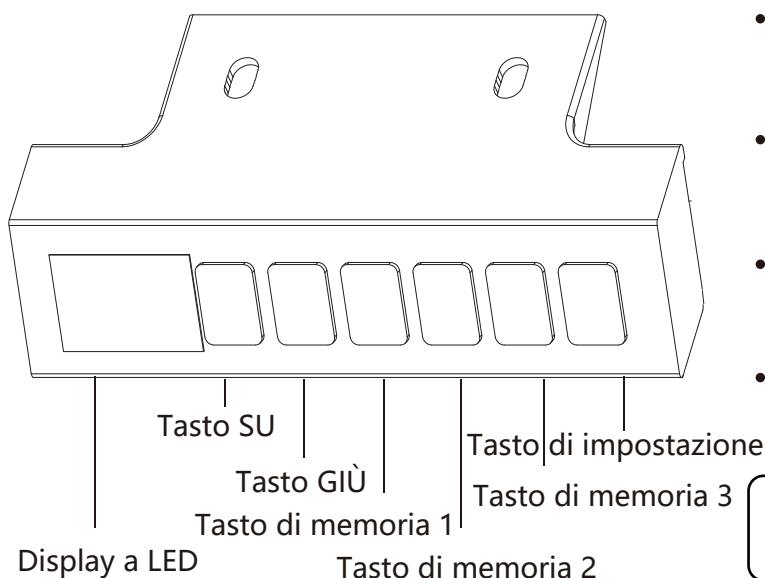

- **Display a LED:**

Premere un tasto qualsiasi per accendere il display a LED.

- **Tasto SU:**

Premere e tenere premuto il tasto SU per sollevare la scrivania.

- **Tasto GIÙ:**

Premere e tenere premuto il tasto GIÙ per abbassare la scrivania.

- **Tasto di memoria:**



Devi completare il processo di inizializzazione per ripristinare la scrivania prima di utilizzarla per la prima volta.



Quando il display mostra "E-1" o "RST", significa che è in corso un'operazione di reset; si prega di continuare a premere e tenere premuto il tasto di discesa "V" come richiesto dal manuale fino a quando non appare il valore di altezza minima, quindi rilasciare il pulsante.

## Introduzione dettagliata delle funzioni dei tasti

### Ripristina

Dopo aver raggiunto la posizione di altezza minima, premere e tenere premuto per 7 secondi. Quando lo schermo a LED lampeggia "RST" e "E-1", rilasciare il tasto "V" e premere di nuovo il tasto. Dopo che il desktop è sceso al punto zero meccanico più basso, tornare indietro di 5 mm, il display a LED mostrerà il valore di altezza minima e il ripristino è completato.

### Imposta l'altezza di memoria + //

Premere il tasto S una volta e il valore di altezza inizierà a lampeggiare. A questo punto, premere i tasti 1, 2 e 3 per salvare l'altezza corrente nella posizione corrispondente.

### Eeguire l'altezza di memoria

In stato normale, premere il tasto numerico per richiamare la sua altezza corrispondente e il tavolo alzante si muoverà automaticamente verso la posizione corrispondente.

### Tasto di blocco

Premere e tenere premuto il tasto S per 3 secondi. Quando lo schermo a LED mostra "SET", imparare ad aprire il tasto S. Premere il tasto numerico 3 per entrare nello stato di blocco dello schermo. A questo punto, lo schermo a LED lampeggia e mostra "OFF".

Quando lo schermo è bloccato, premere e tenere premuto il tasto S per 3 secondi, e lo schermo a LED mostrerà il valore di altezza. A questo punto, rilasciare il tasto S per completare lo sblocco.

### Ripristina le impostazioni di fabbrica

Premere e tenere premuto il tasto S per 9 secondi, rilasciare il tasto S quando lo schermo a LED mostra "FAC", e operare nuovamente il tasto S per ripristinare le impostazioni di fabbrica.

## Istruzioni per il codice di errore

Codice di errore	Motivo	Soluzione
Err	Err viene visualizzato quando la sequenza del cavo di comunicazione tra il controller manuale e la scatola di controllo è errata.	/
E-1	Quando il sistema non salva la posizione corrente, lo schermo LED lampeggia alternativamente mostrando "E-1".	Ripristinare premendo a lungo il tasto finché lo schermo LED non mostra l'altezza minima e l'allerta viene rilasciata.
E-2	Quando il motore è bloccato, il LED mostra "E-2".	/
E-5	Quando il motore appare: il cavo di collegamento è scollegato/allentato, lo schermo LED lampeggia alternativamente mostrando "E-5".	Controllare i cavi di connessione tra tutti i motori e il controller per garantire che siano saldi, quindi ripristinare premendo a lungo il tasto giù finché lo schermo LED non mostra l'altezza minima e rimuovere l'allerta.
ovr	Quando il carico supera il valore impostato, lo schermo LED lampeggia mostrando "ovr". A questo punto, è necessario rimuovere il peso del desktop e accendere il controller dopo averlo spento. Questa allerta può essere rimossa.	<ol style="list-style-type: none"> <li>1. Il carico normale deve essere controllato al di sotto di 120KG</li> <li>2. Quando la corrente supera i 4A, verrà attivata la funzione di protezione da sovraccarico.</li> </ol>
hot	Quando la temperatura interna del controller supera i 60±5 gradi, il LED mostra "hot".	/
voL	Quando la tensione di ingresso del controller supera i 34V, il LED mostra "voL".	<ol style="list-style-type: none"> <li>1. Quando la tensione supera i 32V, il controller si spegne e lo schermo LED è nero;</li> <li>2. Quando la tensione scende a 32V, il sistema risponderà automaticamente e il LED mostrerà l'altezza in tempo reale.</li> </ol>
hot	Dopo che il motore è in funzione continua per 5 minuti, lo schermo LED mostra "hot" e può funzionare normalmente dopo aver atteso 10 minuti.	<ol style="list-style-type: none"> <li>1. Il funzionamento continuo significa che l'intervallo di funzionamento è entro 3 secondi.</li> <li>2. Questa allerta può essere rimossa anche quando il sistema di controllo viene riacceso.</li> </ol>
E-3	Durante il funzionamento, quando viene bloccato improvvisamente, lo schermo LED lampeggia "E-3", ferma l'azione e si muove di 30 mm nella direzione opposta, quindi lo schermo LED mostra l'altezza in tempo reale.	Si deve garantire che il tavolo non vibri significativamente, non urti ostacoli o non si inclini durante il funzionamento.

# CONTENU DU COLIS

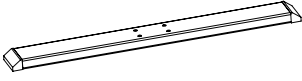

A x 2



B x 1



C x 1



D x 2

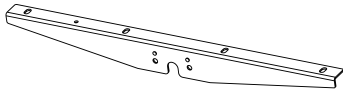

F x 2

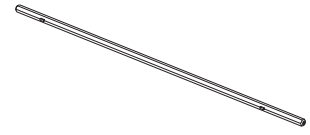

G x 1

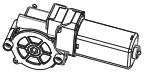

I x 1

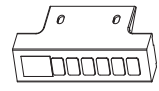

J x 1

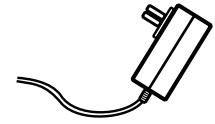

K x 1

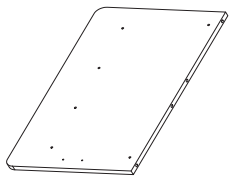

L x 1

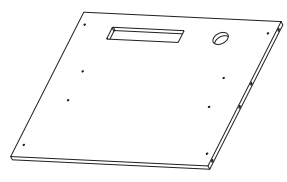

M x 1

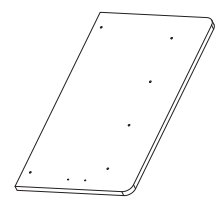

N x 1

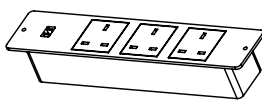

Y x 1

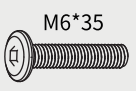

O x 8



P x 32

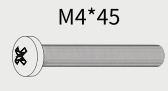

Q x 2



R x 2



S x 1

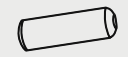

T x 8



U x 4

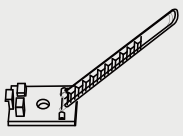

V x 2



W x 4



X x 2



Z x 1

## 1 Installation des pieds

Lorsque le sol est inégal, le patin de pied peut être tourné pour équilibrer la table.

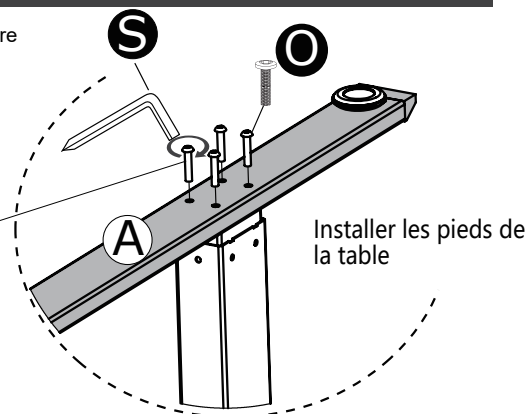
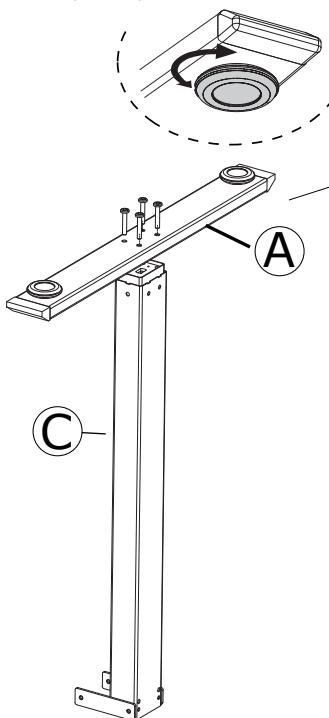
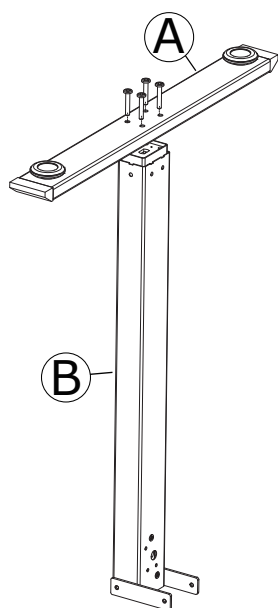

A x 2  
B x 1  
C x 1



## 2 Installer le moteur

### Étape1

Insérer la tige hexagonale dans l'encoche du moteur dans le sens de la flèche.

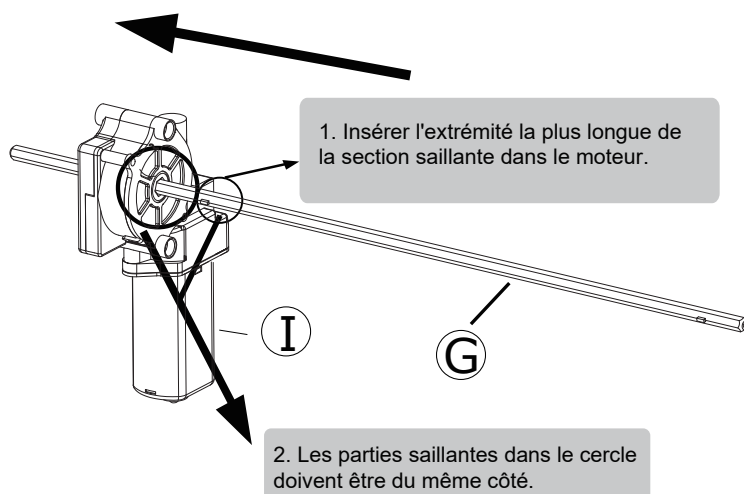

### Étape2

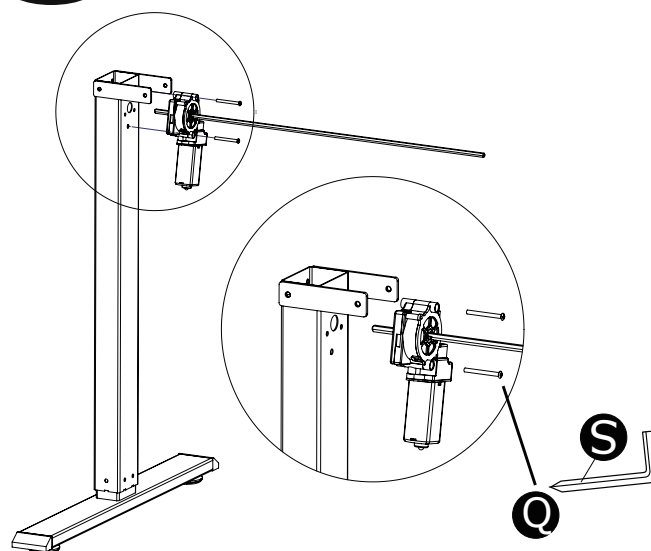

I x 1  
G x 1

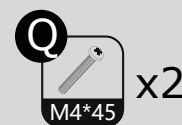

### 3 Installation de la tige d'entraînement-1

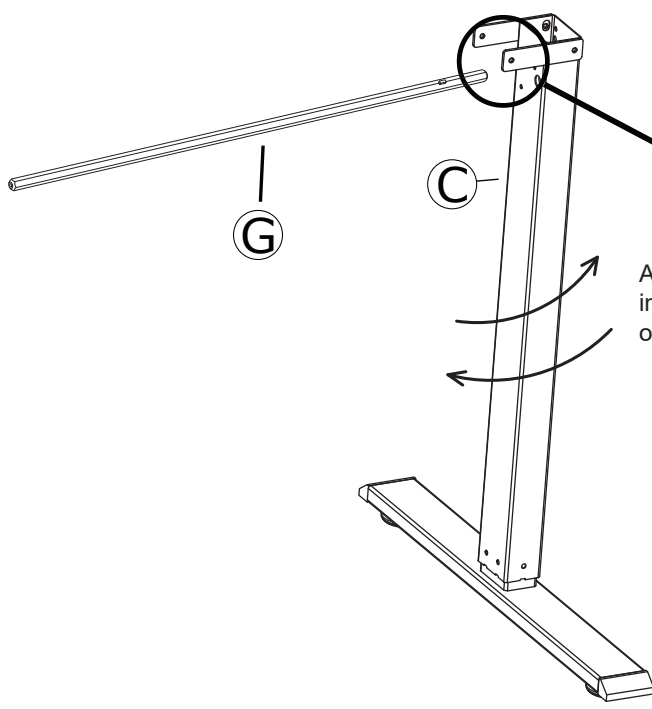

Insérez-la dans la boîte de vitesses d'un côté

Alignez la tige du moteur avec le pied (C). Si l'alignement est incorrect, déplacez doucement le pied de gauche à droite pour obtenir un ajustement sûr.

G x 1

### 4 Installation de la tige d'entraînement-2

Comme indiqué sur la figure suivante

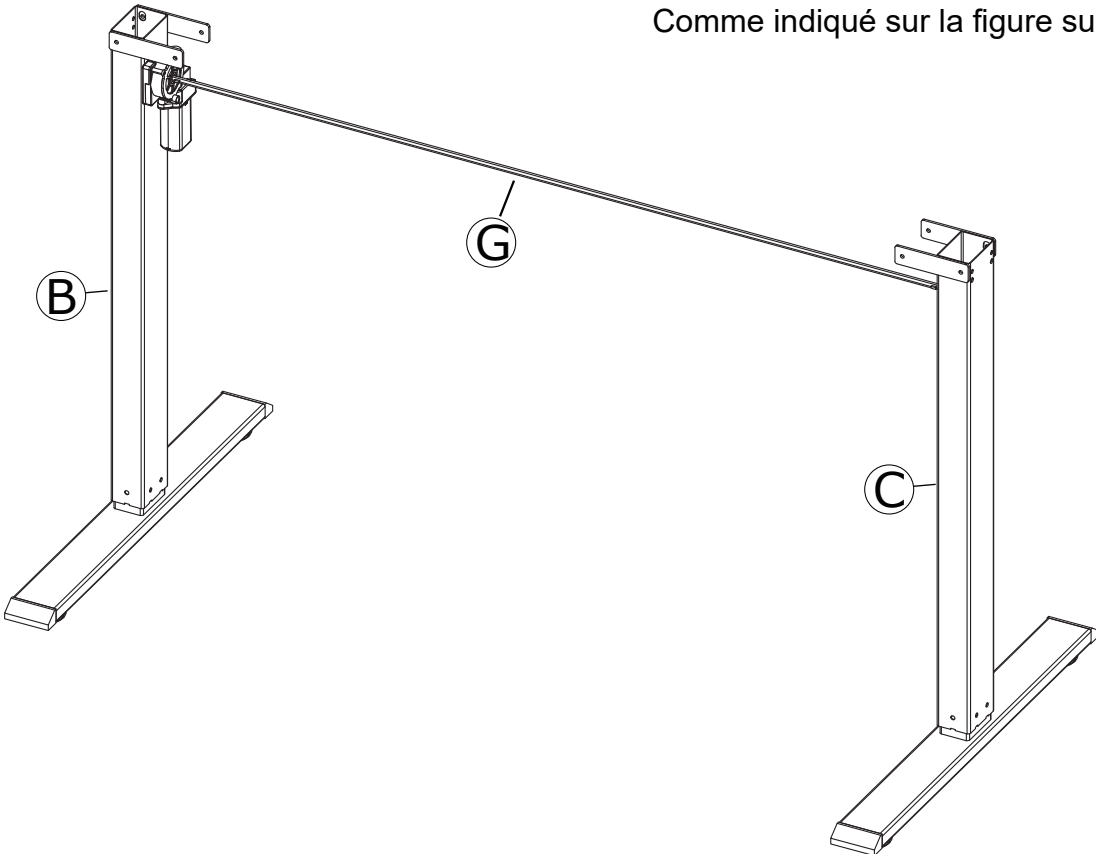

5 Installation de la poutre

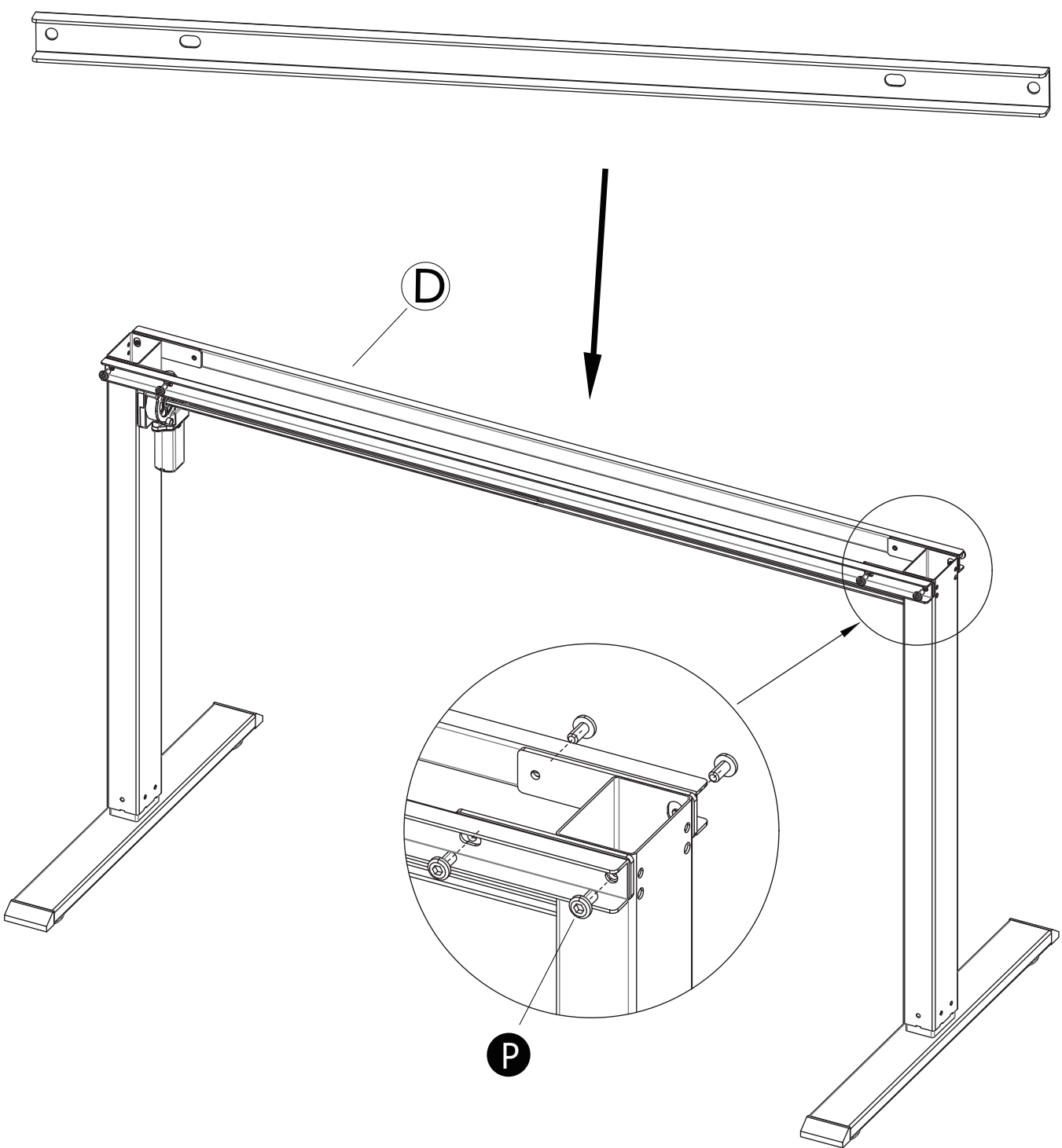

D x 2

P  
M6\*12 x8

# 6 Installation de l'aile latérale

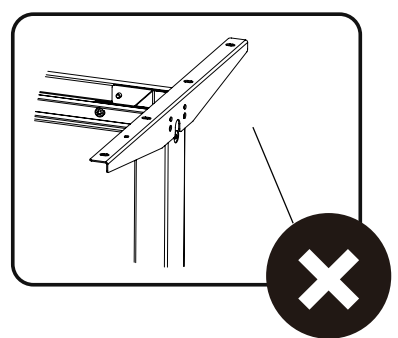
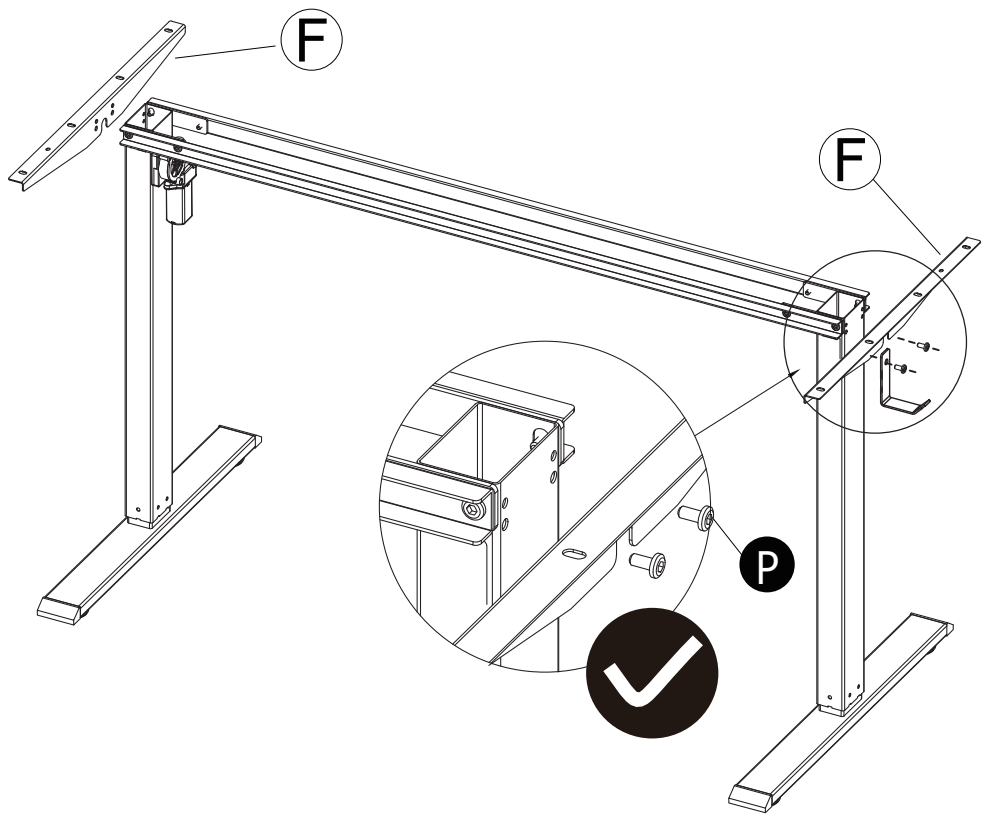

⚠ Démonstration incorrecte

F x 2  
Z x 1

P  
M6\*12 x4

# 7 Installation du panneau-1

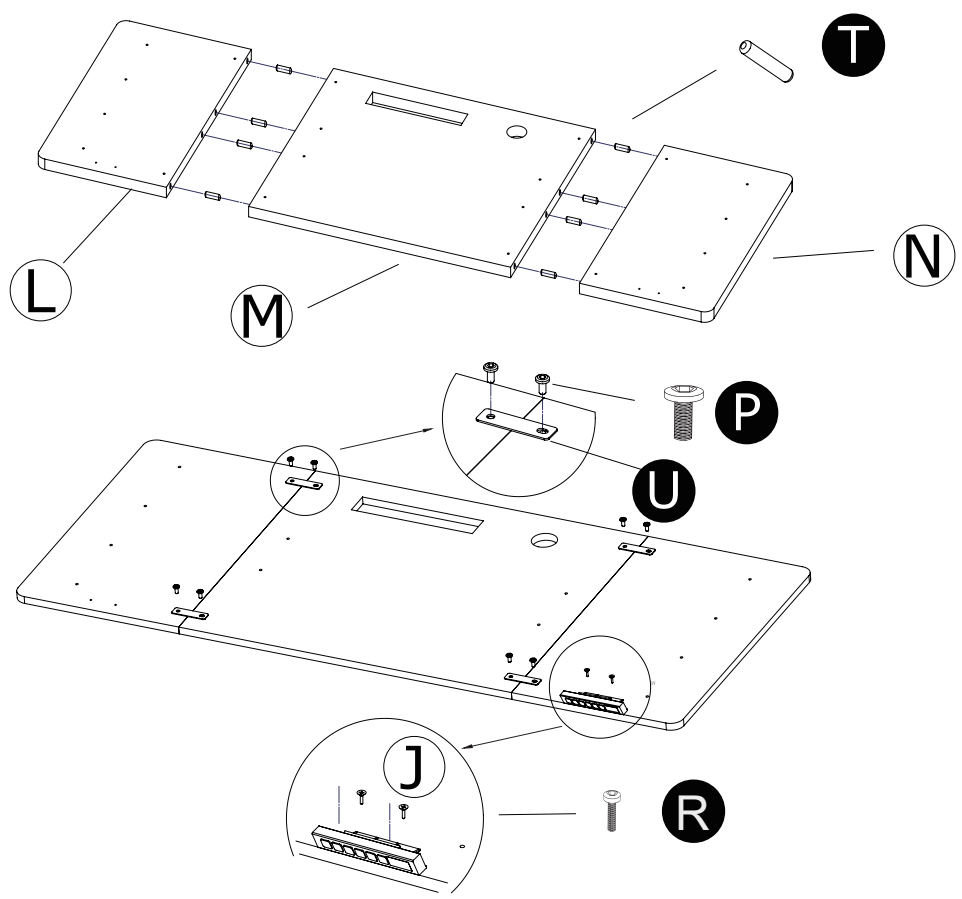

T x8

J x 1  
L x 1  
M x 1  
N x 1

U x4

R M4\*12 x2

P M6\*12 x8

# 8 Installation du panneau-2

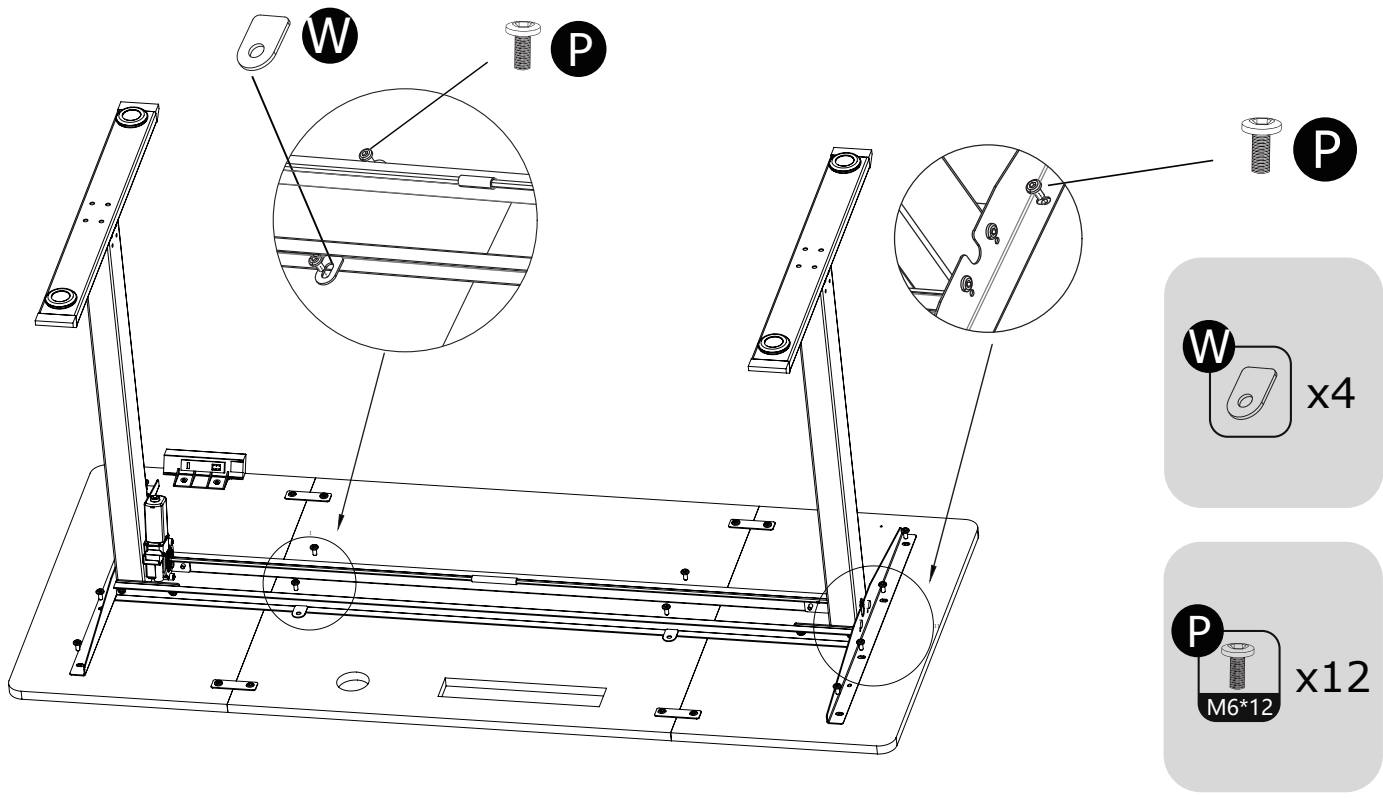

# 9 Connexion des câbles

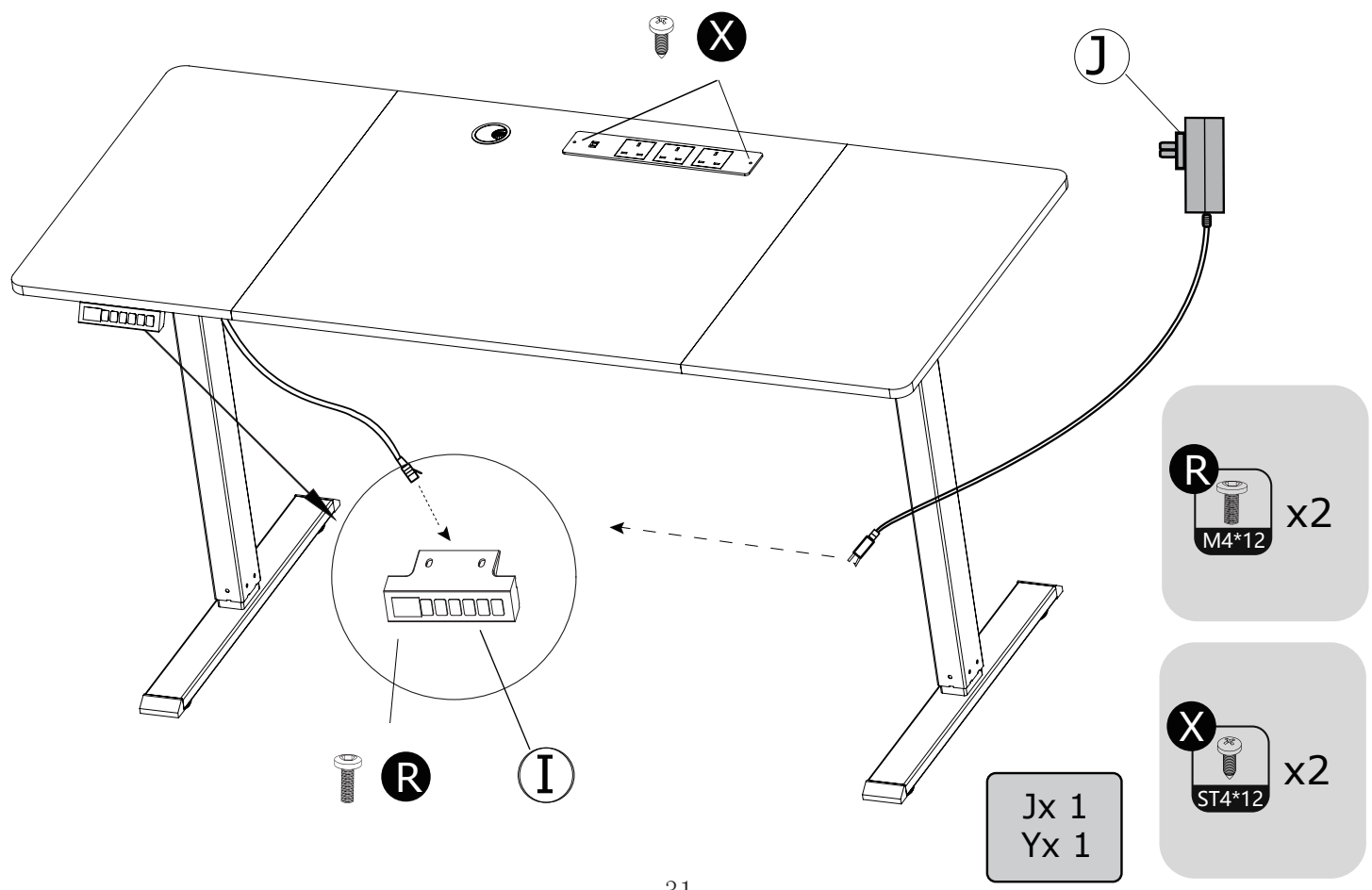

## Fonctionnement du contrôleur de réglage de la hauteur

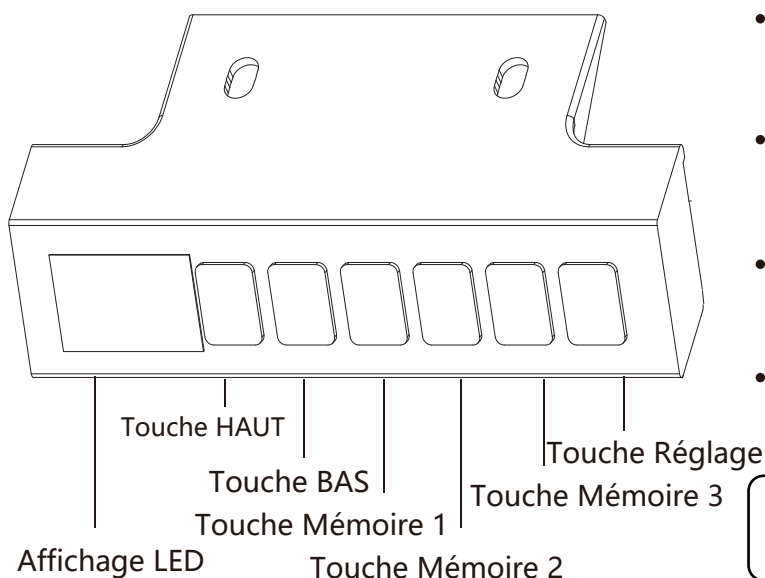

### • Affichage LED:

Appuyez une fois sur n'importe quelle touche pour réveiller l'affichage LED.

### • Touche HAUT:

Appuyez et maintenez la touche HAUT pour élever le bureau.

### • Touche BAS:

Appuyez et maintenez la touche BAS pour abaisser le bureau.

### • Touche Mémoire:



 Vous devez terminer le processus d'initialisation pour réinitialiser votre bureau avant de l'utiliser pour la première fois.



Lorsque l'affichage montre "E-1" ou "RST", cela signifie qu'une opération de réinitialisation est en cours. Veuillez continuer à appuyer sur la touche de descente "V" comme indiqué dans le manuel d'instructions jusqu'à ce que la valeur de hauteur minimale apparaisse, puis relâchez le bouton.

## Introduction détaillée des fonctions des touches

### Réinitialisation

Après avoir atteint la position de hauteur la plus basse, appuyez et maintenez pendant 7 secondes.

Lorsque l'écran LED clignote entre "RST" et "E-1", relâchez la touche "V", puis appuyez et maintenez de nouveau la touche. Une fois que le bureau atteint le point zéro mécanique le plus bas et recule de 5 mm, l'écran LED affiche la valeur de hauteur minimale, et la réinitialisation est terminée.

### Définir la hauteur mémoire +

Appuyez une fois sur la touche S, et la valeur de hauteur commence à clignoter. À ce moment-là, appuyez sur les touches 1, 2 et 3 pour enregistrer la hauteur actuelle à la position correspondante.

### Exécuter la hauteur mémoire

En état normal, appuyez sur la touche numérique pour rappeler la hauteur correspondante, et le bureau se déplacera automatiquement à la position mémorisée.

### Verrouillage de la touche

Appuyez et maintenez la touche S pendant 3 secondes. Lorsque l'écran LED affiche "SET", relâchez la touche S. Appuyez sur la touche numérique 3 pour entrer en mode de verrouillage de l'écran. À ce moment-là, l'écran LED clignote et affiche "OFF".

Lorsque l'écran est verrouillé, appuyez et maintenez la touche S pendant 3 secondes. L'écran LED affichera la valeur de hauteur, relâchez ensuite la touche S pour terminer le déverrouillage.

### Rétablir les paramètres d'usine

Appuyez et maintenez la touche S pendant 9 secondes, relâchez la touche S lorsque l'écran LED affiche "FAC", puis appuyez de nouveau sur la touche S pour restaurer les paramètres d'usine.

## Instructions des Codes d'Erreur

Code d'Erreur	Raison	Solution
Err	"Err" s'affiche lorsque la séquence de ligne de communication entre le contrôleur manuel et la boîte de contrôle est incorrecte.	/
E-1	Lorsque le système ne sauvegarde pas la position actuelle, l'écran LED clignote alternativement pour afficher "E-1".	Réinitialisez en appuyant longuement sur la touche jusqu'à ce que l'écran LED affiche la hauteur minimale et que l'alarme soit levée.
E-2	Lorsque le moteur est bloqué, l'écran LED affiche "E-2".	/
E-5	Lorsque le moteur présente : la ligne de connexion est déconnectée/relâchée, l'écran LED clignote alternativement pour afficher "E-5".	Vérifiez les lignes de connexion entre tous les moteurs et le contrôleur pour vous assurer qu'elles sont bien connectées, puis réinitialisez en appuyant longuement sur la touche bas jusqu'à ce que l'écran LED affiche la hauteur minimale et que l'alarme soit levée.
ovr	Lorsque la charge dépasse la valeur définie, l'écran LED clignote et affiche "ovr". À ce moment-là, il est nécessaire d'enlever le poids du bureau et de rebrancher l'alimentation après l'avoir coupée. Cette alarme peut être levée.	<ol style="list-style-type: none"> <li>1. La charge normale doit être contrôlée en dessous de 120KG</li> <li>2. Lorsque le courant dépasse 4A, la fonction de protection contre les surcharges est déclenchée</li> </ol>
hot	Lorsque la température interne du contrôleur dépasse 60±5 degrés, l'écran LED affiche "hot".	/
voL	Lorsque la tension d'entrée du contrôleur dépasse 34V, l'écran LED affiche "voL".	<ol style="list-style-type: none"> <li>1. Lorsque la tension dépasse 32V, le contrôleur est coupé et l'écran LED devient noir.</li> <li>2. Lorsque la tension descend à 32V, le système se réinitialise automatiquement et l'écran LED affiche la hauteur en temps réel.</li> </ol>
hot	Après que le moteur a fonctionné en continu pendant 5 minutes, l'écran LED affiche "hot", et il peut fonctionner normalement après 10 minutes d'attente.	<ol style="list-style-type: none"> <li>1. Le fonctionnement ininterrompu signifie que l'intervalle de fonctionnement est inférieur à 3 secondes.</li> <li>2. Cette alarme peut également être levée lorsque le système de contrôle est rebranché.</li> </ol>
E-3	Pendant l'opération, en cas de blocage soudain, l'écran LED clignote "E-3", arrête l'action et fonctionne dans la direction opposée sur 30 mm, puis l'écran LED affiche la hauteur en temps réel.	Il doit être assuré que la table ne vibre pas de manière significative, ne heurte pas d'obstacles ou ne s'incline pas pendant l'opération.

# CONTENIDO DEL PAQUETE

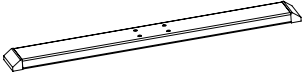

A x 2



B x 1



C x 1



D x 2

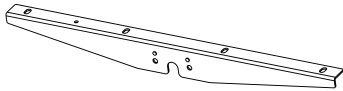

F x 2

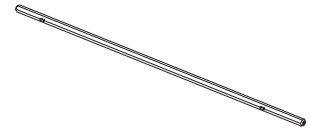

G x 1

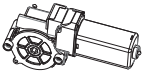

I x 1

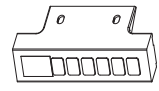

J x 1

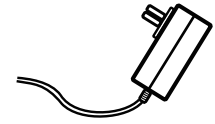

K x 1

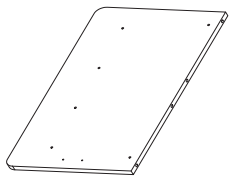

L x 1

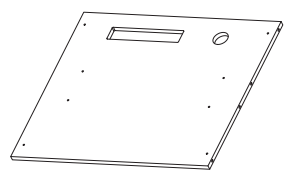

M x 1

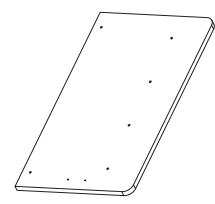

N x 1

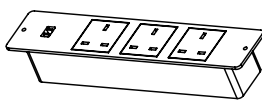

Y x 1

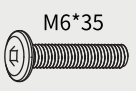

O x 8



P x 32

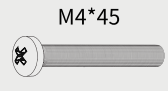

Q x 2



R x 2



S x 1

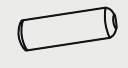

T x 8

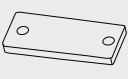

U x 4

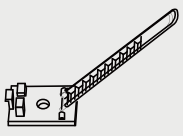

V x 2



W x 4



X x 2



Z x 1

# 1 Instalación de las patas

Cuando el suelo es irregular, se puede girar la pata regulable para lograr equilibrio

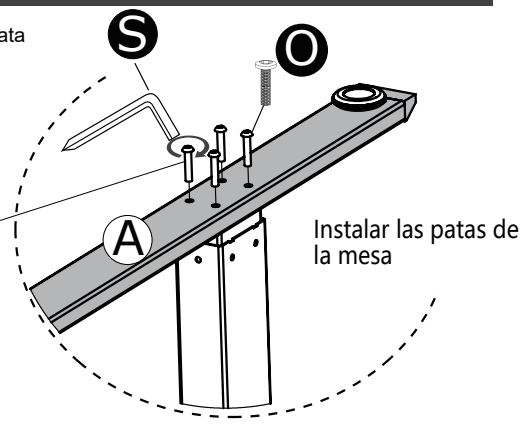
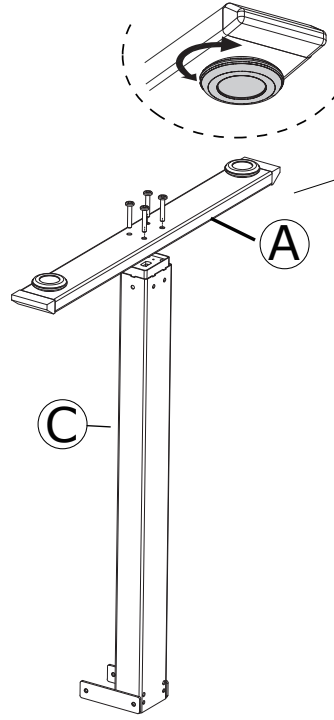
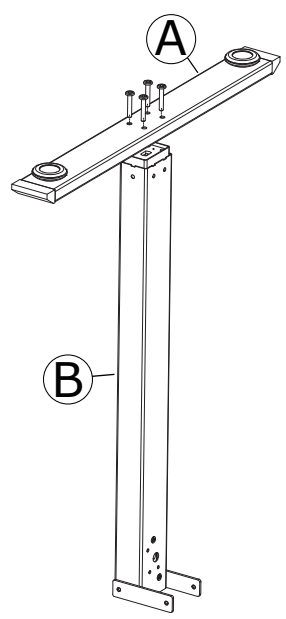

Instalar las patas de la mesa

- A x 2
- B x 1
- C x 1

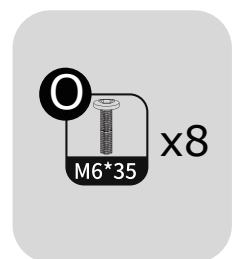

# 2 Instalar el motor

**Paso 1**

Inserte la varilla hexagonal en el agujero de la ranura del motor en la dirección de la flecha.

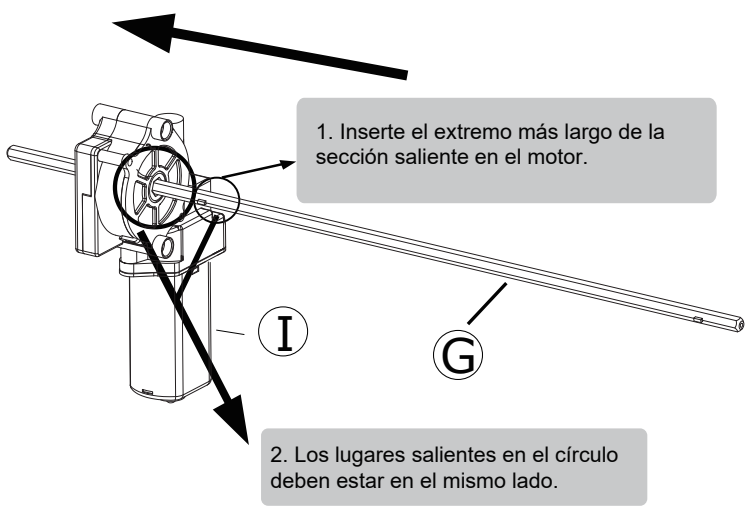

1. Inserte el extremo más largo de la sección saliente en el motor.

2. Los lugares salientes en el círculo deben estar en el mismo lado.

**Paso 2**

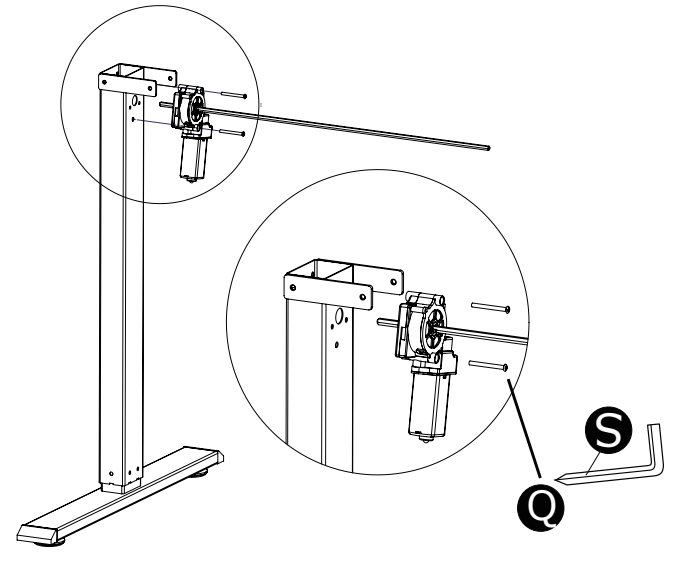

- I x 1
- G x 1

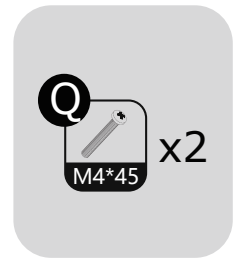

### 3 Instalación de la varilla de accionamiento-1

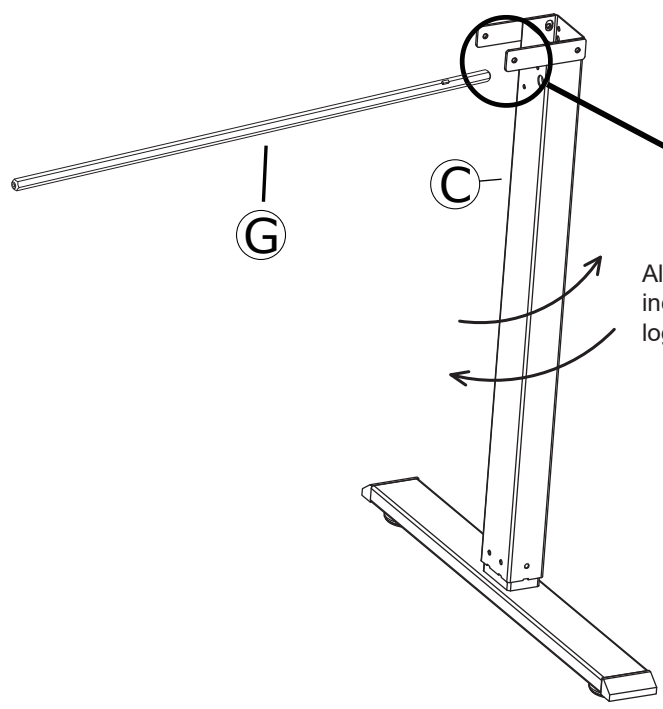

Insértela en la caja de engranajes de un lado

Alinee la varilla del motor con la pata(C). Si la alineación es incorrecta, mueva suavemente la pata de un lado a otro para lograr un ajuste seguro.

G x 1

### 4 Instalación de la varilla de accionamiento-2

Como se muestra en la figura siguiente

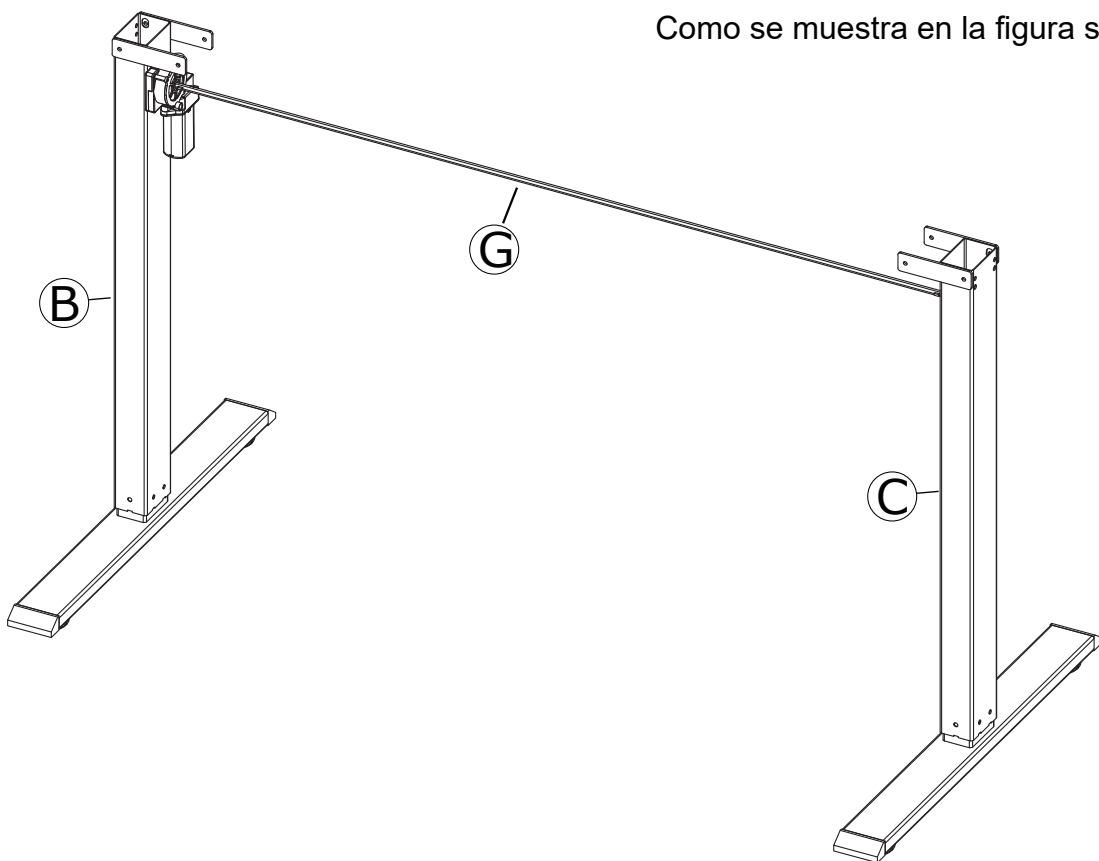

5 Instalación del haz

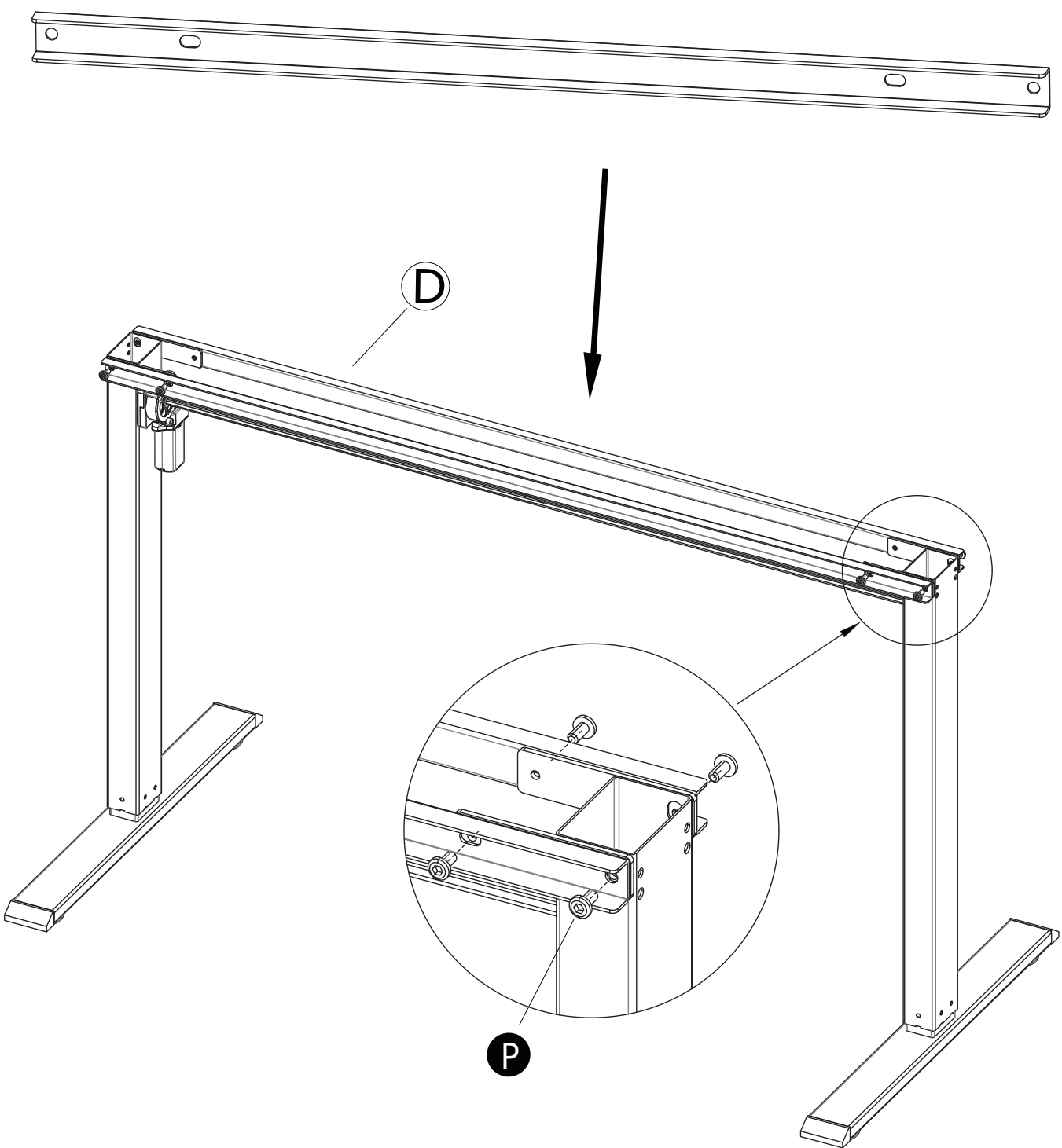

D x 2

P M6\*12 x8

**6** Instalación de las alas laterales

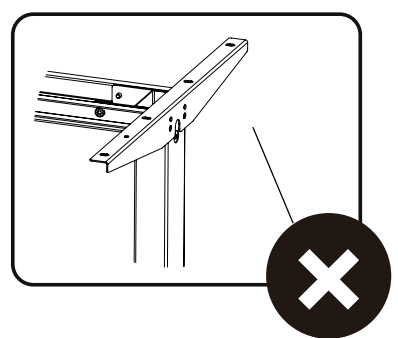
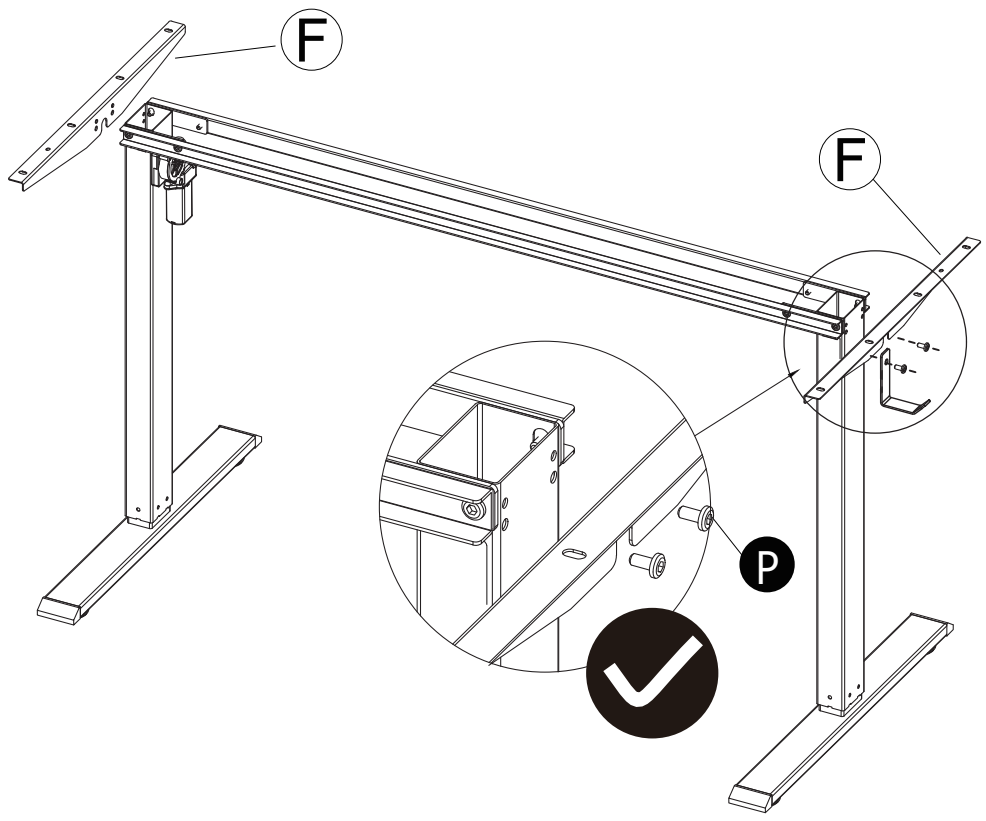

**!** Demostración incorrecta

F x 2  
Z x 1

**P**  
M6\*12 x4

**7** Instalación del panel-1

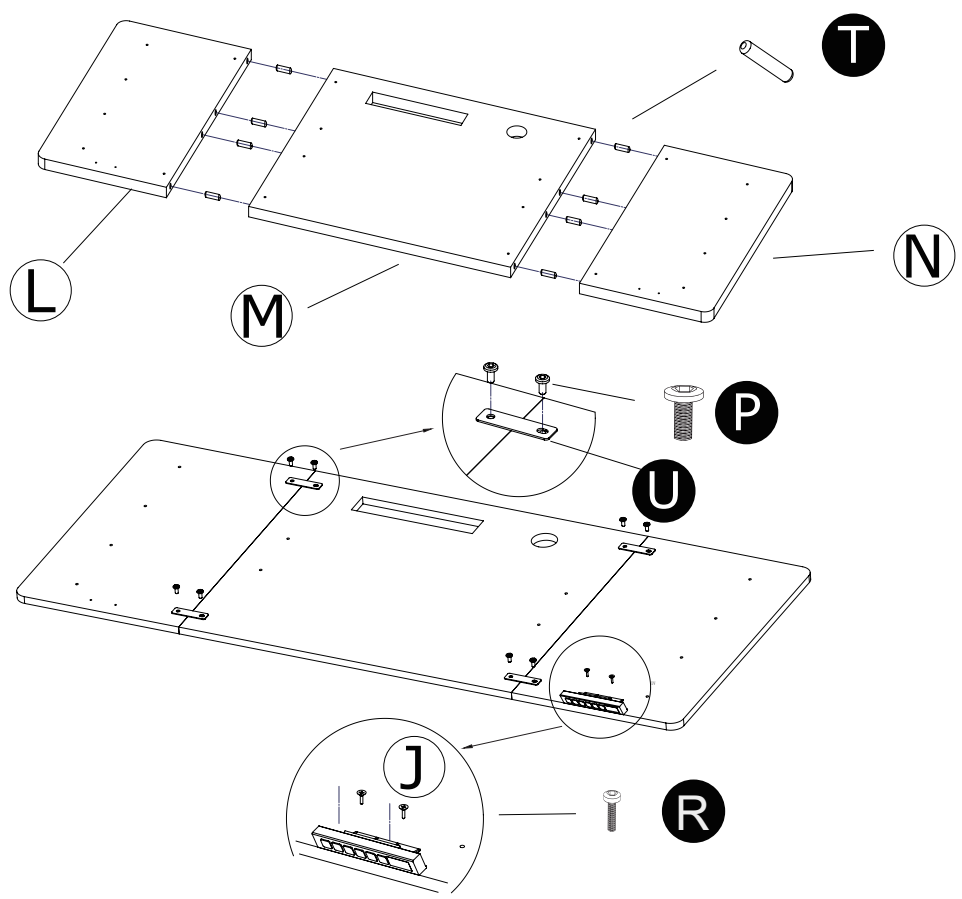

**T**  
x8

J x 1  
L x 1  
M x 1  
N x 1

**U**  
x4

**R**  
M4\*12 x2

**P**  
M6\*12 x8

# 8 Instalación del panel-2

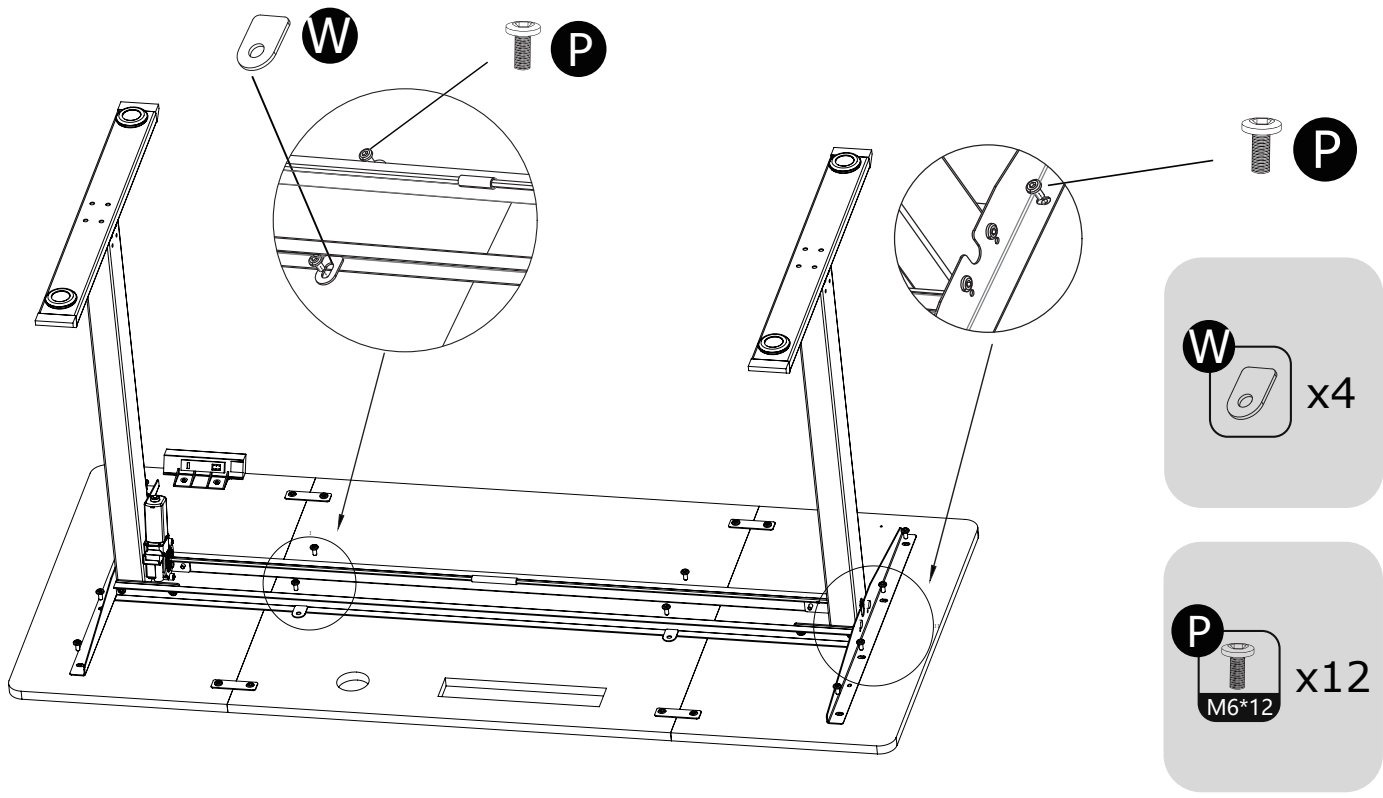

# 9 Conexión de cables

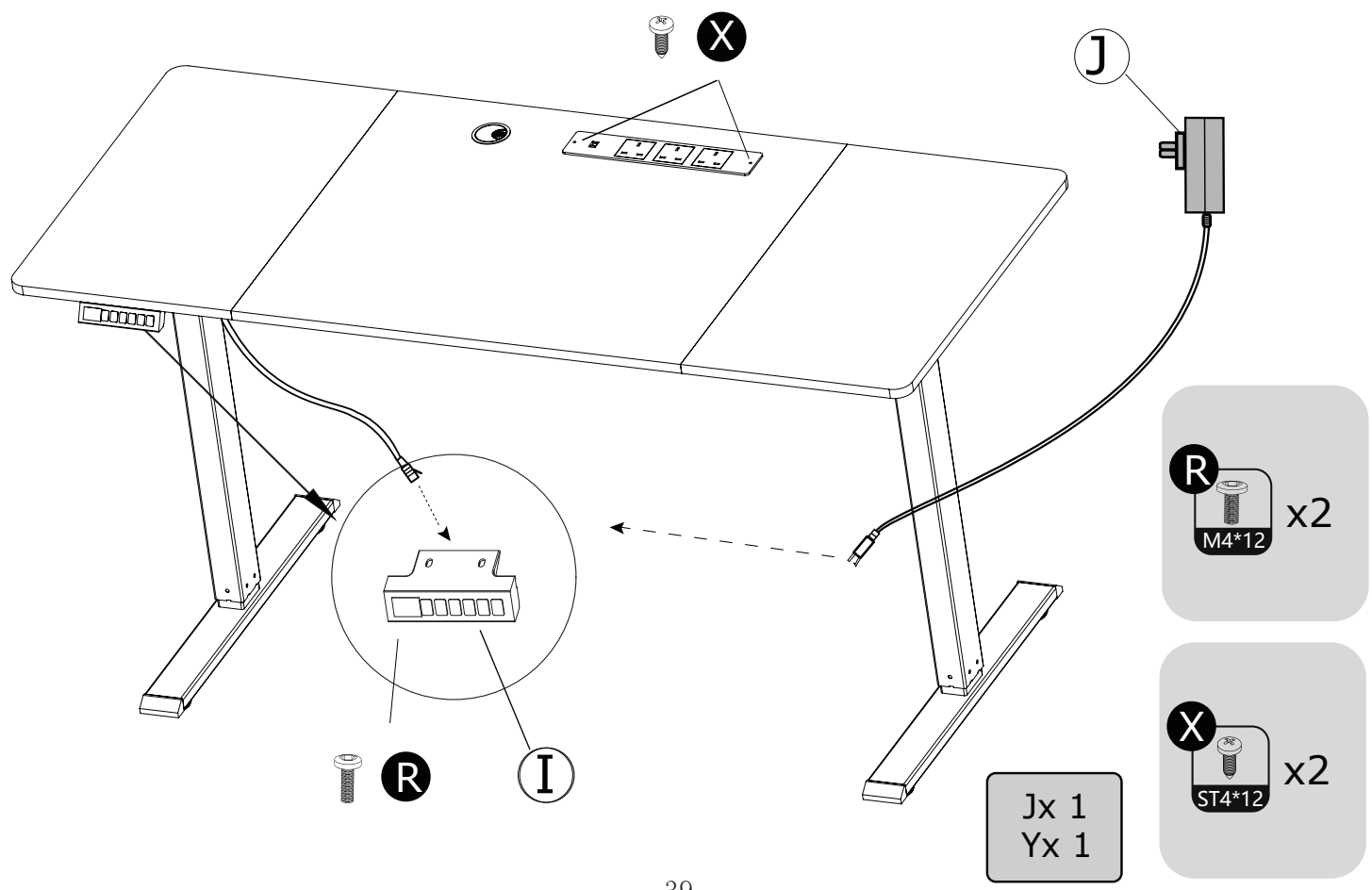

## Operación del controlador de ajuste de altura

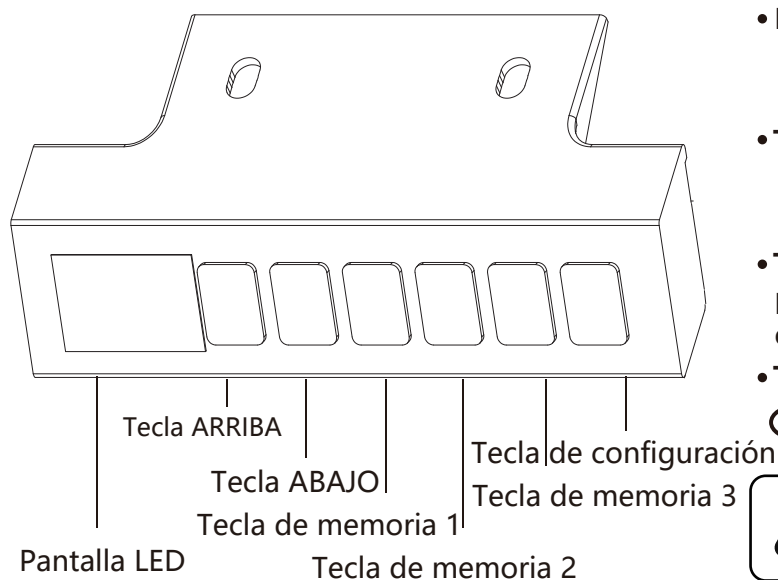

- **Pantalla LED:**

Presione cualquier tecla una vez para activar la pantalla LED.

- **Tecla ARRIBA:**

Mantenga presionada la tecla ARRIBA para levantar el escritorio.

- **Tecla ABAJO:**

Mantenga presionada la tecla ABAJO para bajar el escritorio.

- **Tecla de memoria:**



Debe completar el proceso de inicialización para restablecer su escritorio antes de usarlo por primera vez.



Cuando la pantalla muestra "E-1" o "RST", significa que se está realizando una operación de restablecimiento; continúe presionando y manteniendo la tecla de descenso "V" como se indica en el manual hasta que aparezca el valor de altura mínima, y luego suelte el botón.

## Introducción detallada a las funciones de las teclas

### Restablecer

Después de llegar a la posición de altura mínima, mantenga presionado durante 7 segundos. Cuando la pantalla LED parpadea "RST" y "E-1", suelte la tecla "V" y presione nuevamente la tecla. Después de que el escritorio baje al punto cero mecánico más bajo, retroceda 5 mm, la pantalla LED mostrará el valor de altura mínima y el restablecimiento se completará.

### Establecer altura de memoria + //

Presione la tecla S una vez, y el valor de altura comenzará a parpadear. En este momento, presione las teclas 1, 2 y 3 para guardar la altura actual en la posición correspondiente.

### Ejecutar altura de memoria

En estado normal, presione la tecla numérica para llamar a su altura correspondiente, y la mesa elevadora se moverá automáticamente a la posición correspondiente.

### Tecla de bloqueo

Mantenga presionada la tecla S durante 3 segundos. Cuando la pantalla LED muestra "SET", aprenda a abrir la tecla S. Presione la tecla numérica 3 para entrar en el estado de bloqueo de la pantalla. En este momento, la pantalla LED parpadea y muestra "OFF".

Cuando la pantalla está bloqueada, mantenga presionada la tecla S durante 3 segundos, y la pantalla LED mostrará el valor de altura. En este momento, suelte la tecla S para completar el desbloqueo.

### Restaurar configuraciones de fábrica

Mantenga presionada la tecla S durante 9 segundos, suelte la tecla S cuando la pantalla LED muestre "FAC", y opere la tecla S nuevamente para restaurar las configuraciones de fábrica.

Instrucciones del código de error		
Código de error	Razón	Solución
Err	Err se muestra cuando la secuencia del cable de comunicación entre el controlador manual y la caja de control es incorrecta.	/
E-1	Cuando el sistema no guarda la posición actual, la pantalla LED parpadea alternando "E-1".	Restablezca presionando la tecla larga hasta que la pantalla LED muestre la altura mínima y se suelte la alarma.
E-2	Cuando el motor está bloqueado, el LED muestra "E-2".	/
E-5	Cuando el motor aparece: el cable de conexión está desconectado/suelto, la pantalla LED parpadea alternando mostrando "E-5".	Verifique los cables de conexión entre todos los motores y el controlador para asegurarse de que estén firmes, y luego restablezca presionando prolongadamente la tecla de descenso hasta que la pantalla LED muestre la altura mínima y elimine la alarma.
ovr	Cuando la carga excede el valor establecido, la pantalla LED parpadea mostrando "ovr". En este momento, es necesario quitar el peso del escritorio y encender el controlador después de apagarlo. Esta alarma se puede eliminar.	<ol style="list-style-type: none"> <li>1. La carga normal debe controlarse por debajo de 120 KG</li> <li>2. Cuando la corriente excede 4A, se activará la función de protección contra sobrecargas.</li> </ol>
hot	Cuando la temperatura interna del controlador supera los 60±5 grados, el LED muestra "hot".	/
voL	Cuando la tensión de entrada del controlador excede 34V, el LED muestra "voL".	<ol style="list-style-type: none"> <li>1. Cuando la tensión supera los 32V, el controlador se apaga y la pantalla LED está en negro;</li> <li>2. Cuando la tensión baja a 32V, el sistema se recuperará automáticamente y el LED mostrará la altura en tiempo real.</li> </ol>
hot	Después de que el motor funcione continuamente durante 5 minutos, la pantalla LED muestra "hot", y puede funcionar normalmente después de esperar 10 minutos.	<ol style="list-style-type: none"> <li>1. La operación ininterrumpida significa que el intervalo de operación está dentro de los 3 segundos.</li> <li>2. Esta alarma también se puede eliminar cuando el sistema de control se vuelve a encender.</li> </ol>
E-3	Durante la operación, cuando se bloquea repentinamente, la pantalla LED parpadea "E-3", detiene la acción y se mueve 30 mm en la dirección opuesta, luego la pantalla LED muestra la altura en tiempo real.	Se debe garantizar que la mesa no vibre significativamente, no choque contra obstáculos ni se incline durante la operación.

# PAKETINNEHÅLL

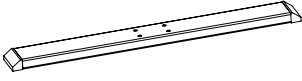

A x 2



B x 1



C x 1



D x 2

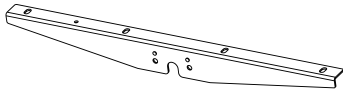

F x 2

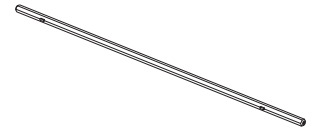

G x 1

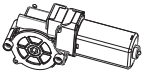

I x 1

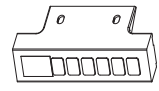

J x 1

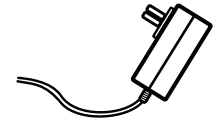

K x 1

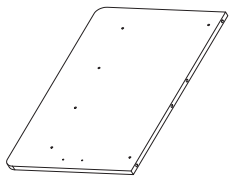

L x 1

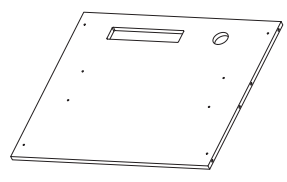

M x 1

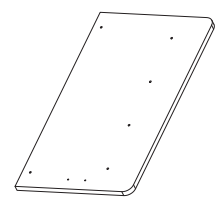

N x 1

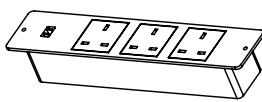

Y x 1

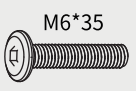

O x 8



P x 32

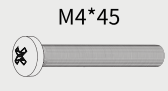

Q x 2



R x 2



S x 1

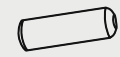

T x 8



U x 4

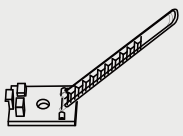

V x 2



W x 4



X x 2

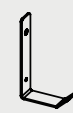

Z x 1

## 1 Fotpå installation

När marken är ojämn kan fotplattan roteras för att uppnå balans.

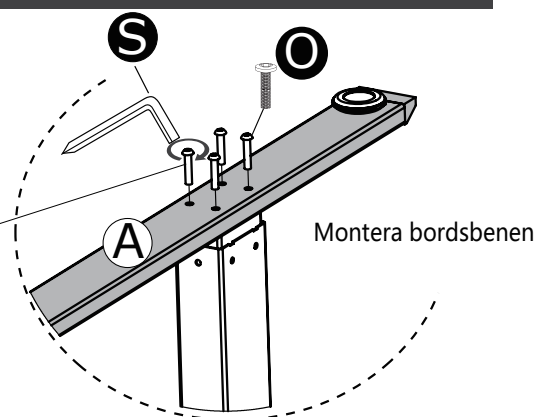
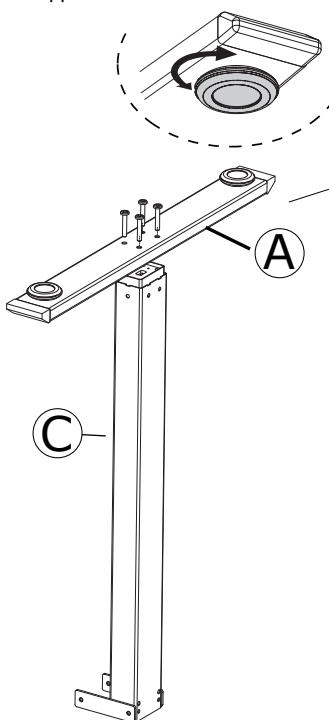
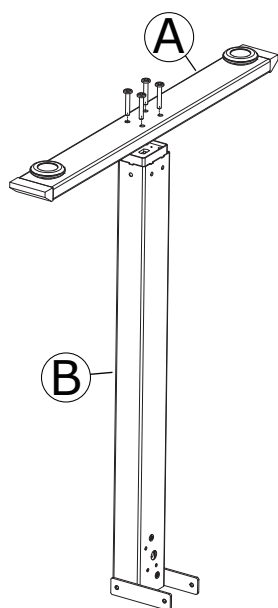

A x 2  
B x 1  
C x 1



## 2 Montera motorn

Steg 1

Sätt in hexstaven i spårhålet på motorn i pilens riktning.

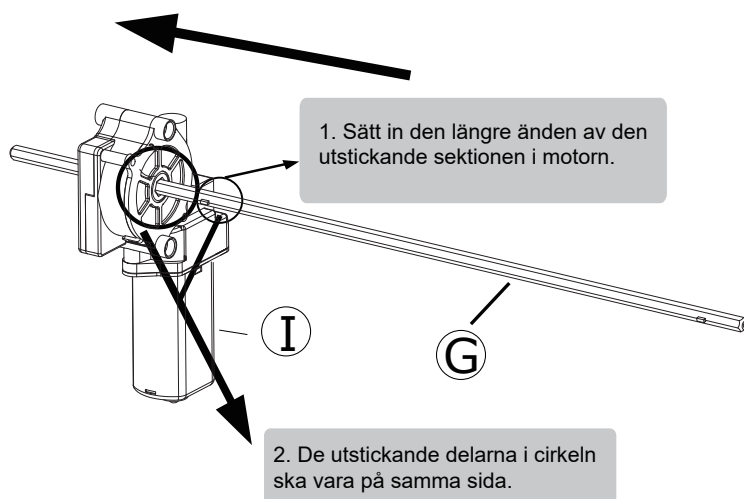

Steg 2

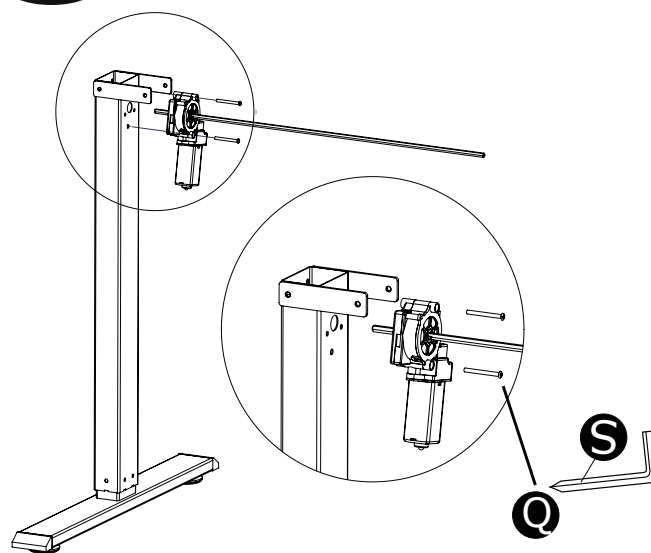

I x 1  
G x 1

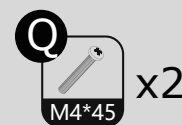

### 3 Montering av drivstaven - 1

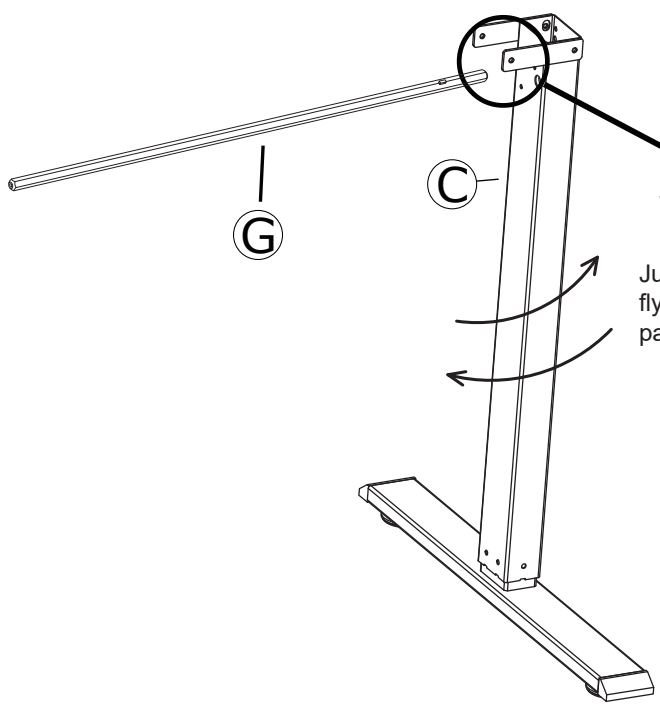

Sätt in den i växellådan på ena sidan

Justera motorröret med ben (C). Om justeringen är felaktig, flytta försiktigt benet fram och tillbaka för att uppnå en säker passform.

G x 1

### 4 Montering av drivstaven - 2

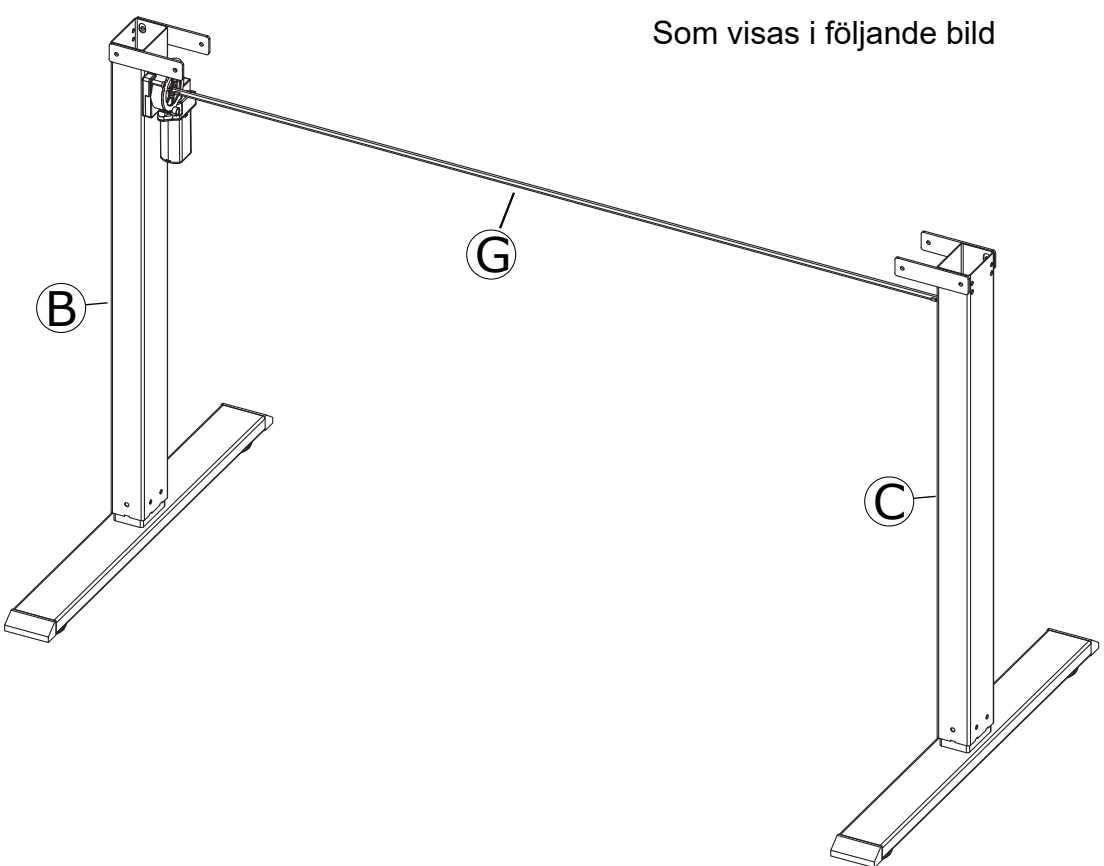

Som visas i följande bild

5 Montering av balk

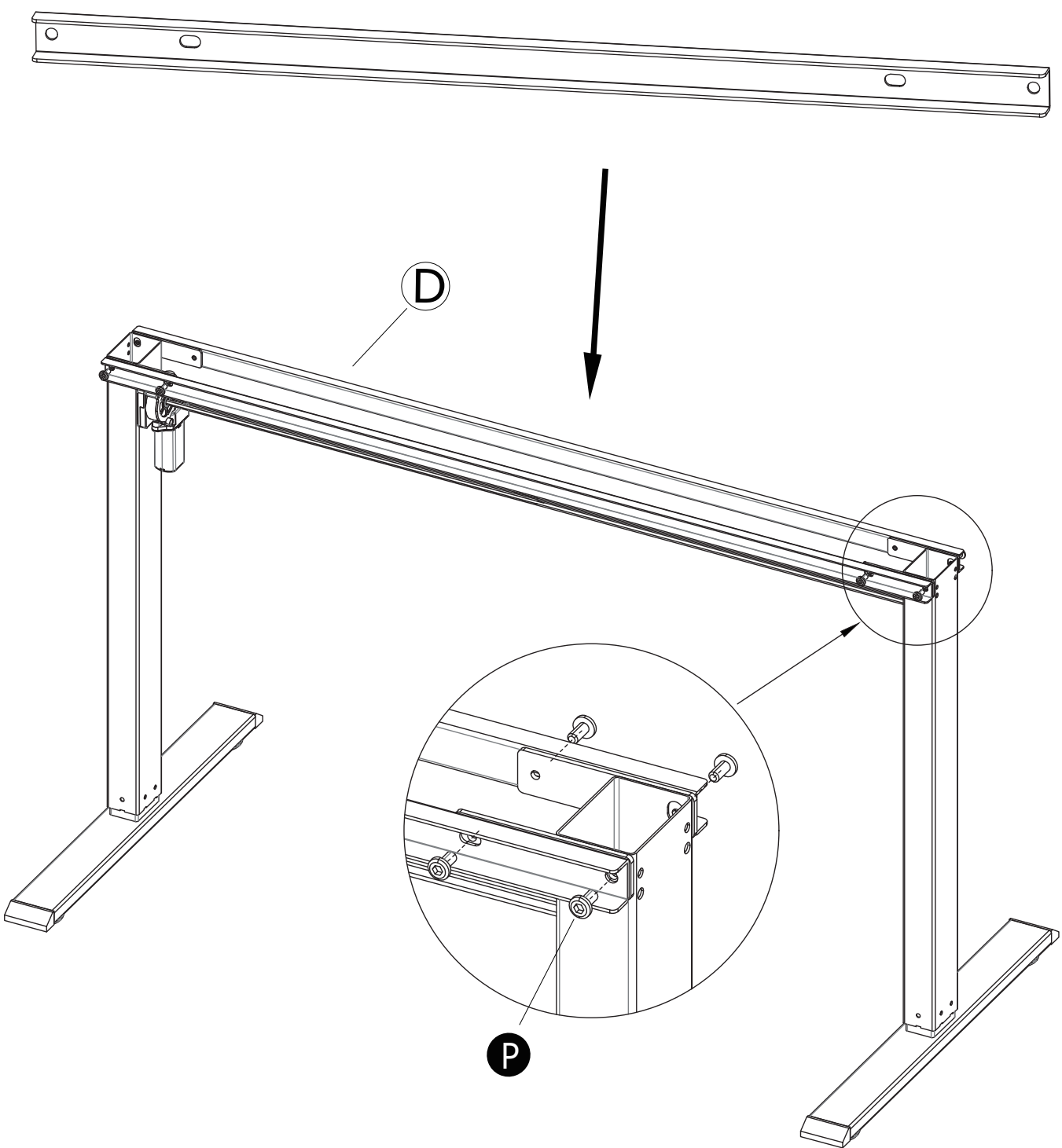

D x 2

P M6\*12 x8

# 6 Montering av sidovinge

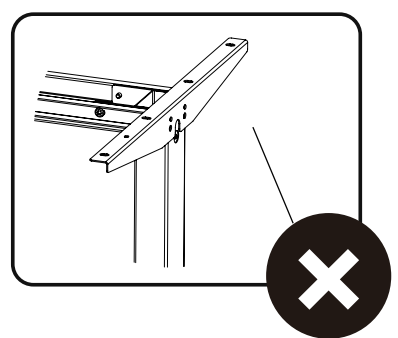
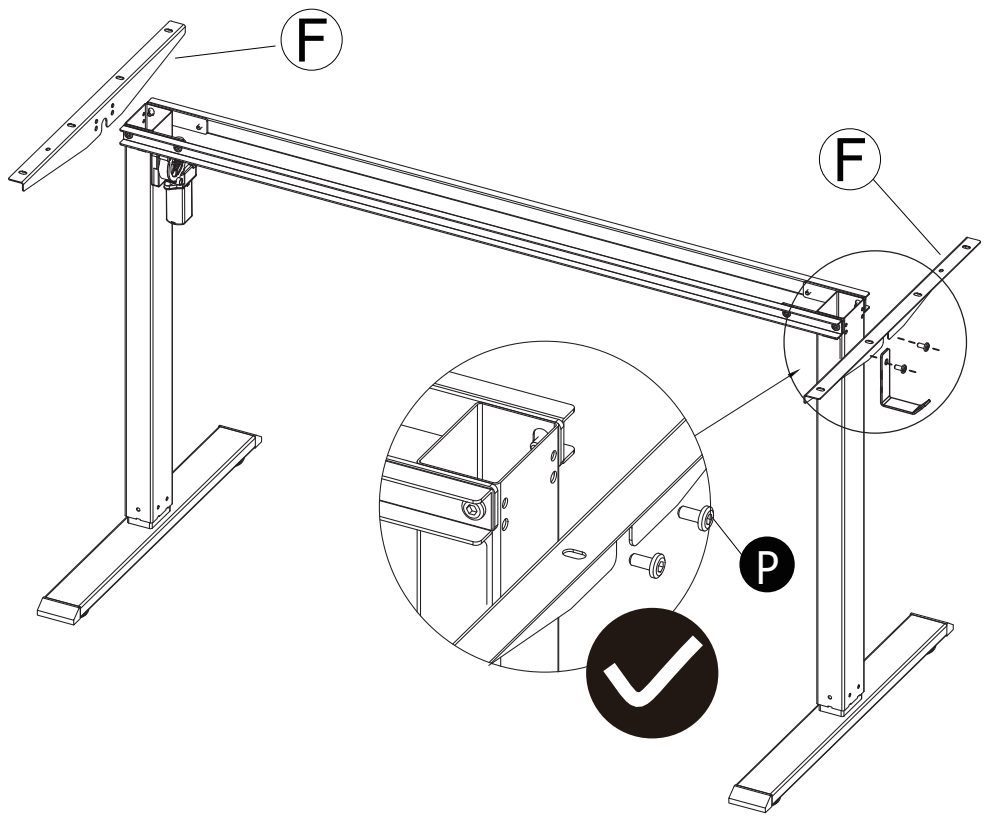

⚠ Felaktig demonstration

F x 2  
Z x 1

P  
M6\*12 x4

# 7 Montering av panel - 1

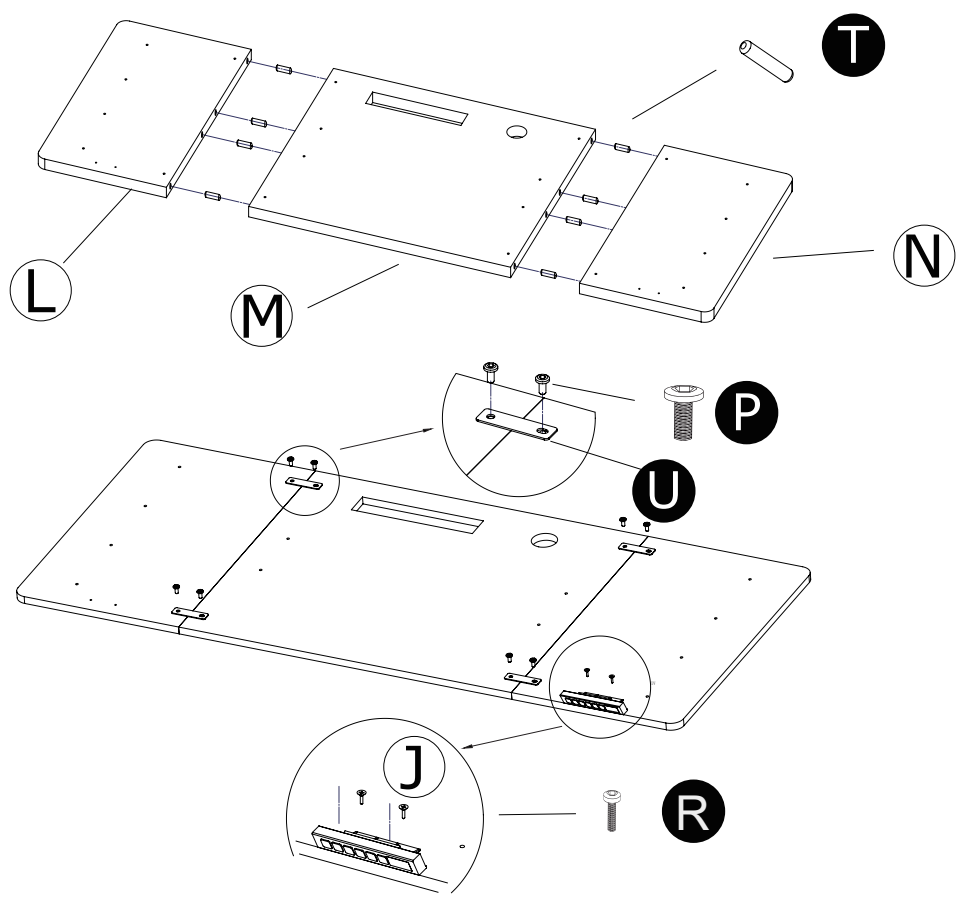

T x8

J x 1  
L x 1  
M x 1  
N x 1

U x4

R  
M4\*12 x2

P  
M6\*12 x8

# 8 Montering av panel - 2

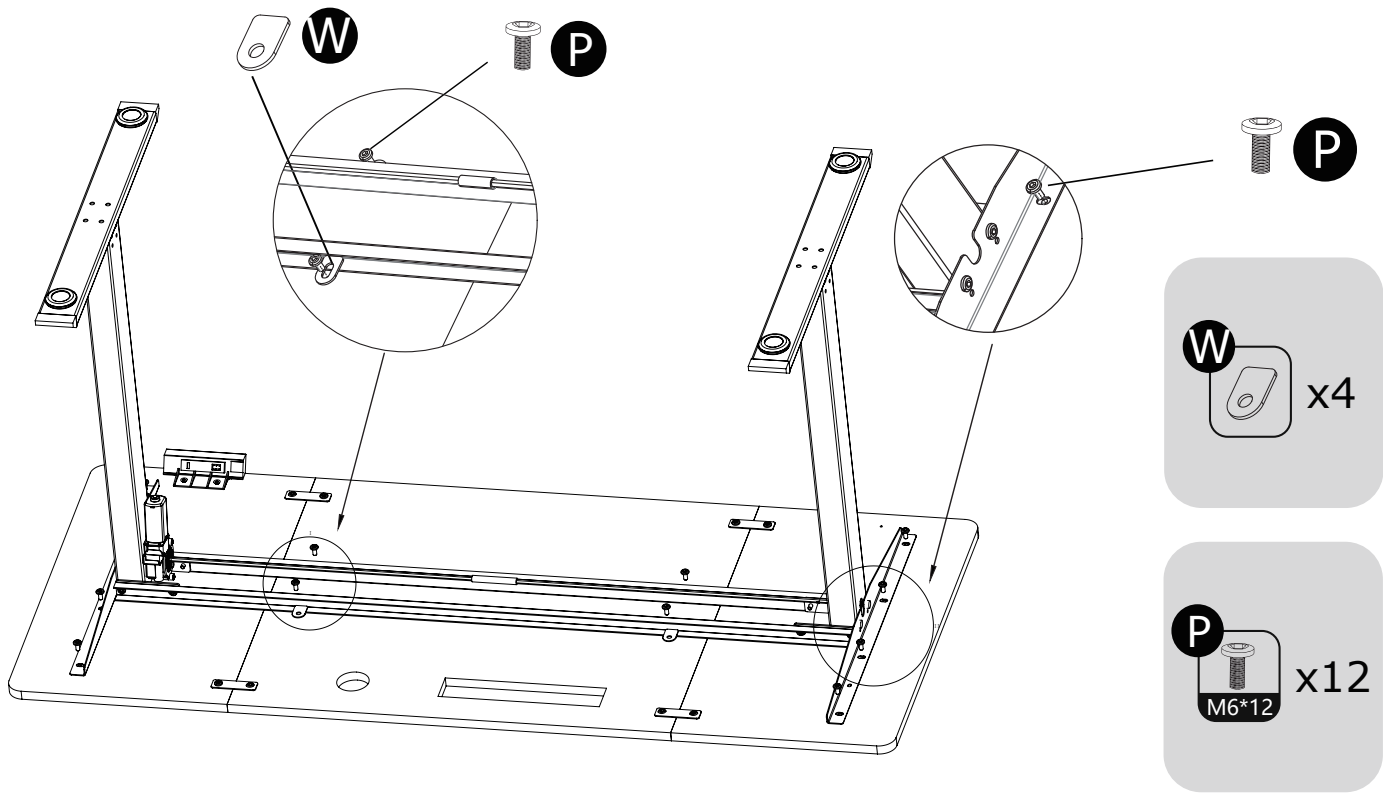

# 9 Anslutning av kablar

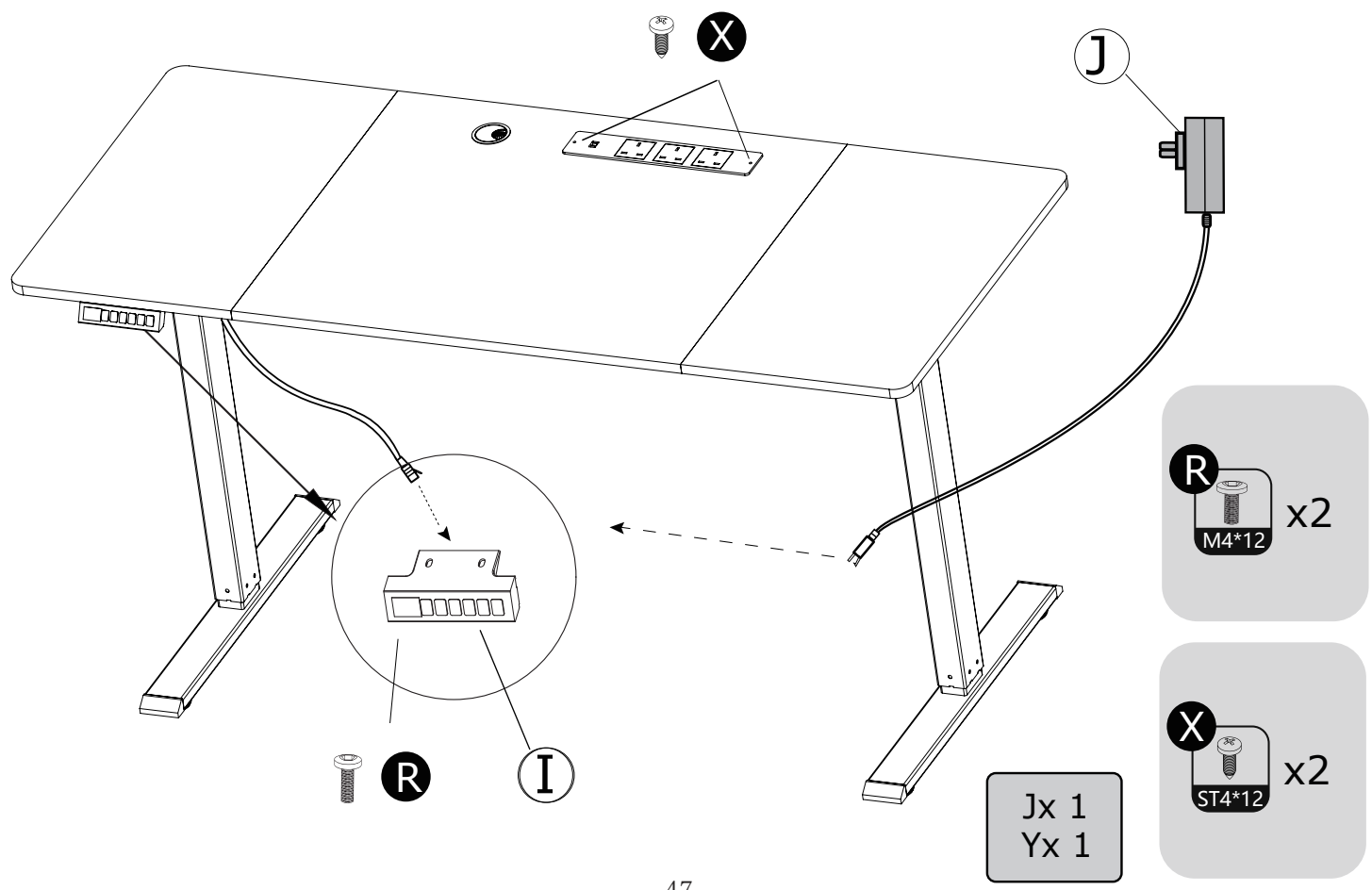

## Höjdjusteringskontrollens funktion

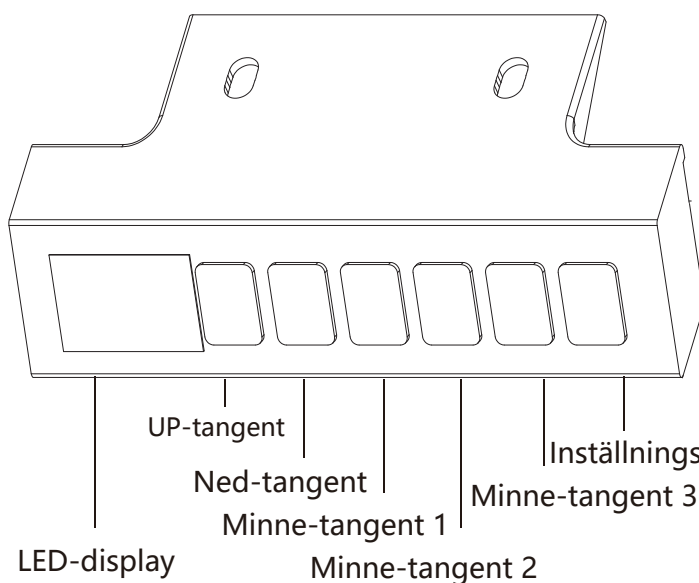

- **LED-display:**

Tryck på valfri knapp en gång för att väcka LED-displayen.

- **UP-tangent:**

Håll in UP-tangenten för att höja skrivbordet.

- **Ned-tangent:**

Håll in DOWN-tangenten för att sänka skrivbordet.

- **Minne-tangent:**

Du måste slutföra initieringsprocessen för att återställa ditt skrivbord innan du använder det för första gången.



När displayen visar "E-1" eller "RST" betyder det att en återställningsoperation pågår. Fortsätt trycka och hålla nere ned-tangenten "V" enligt bruksanvisningen tills det minimi höjdvärdet visas, och släpp sedan knappen.

## Detaljerad introduktion av tangentfunktioner

### Återställ

Efter att ha nått den lägsta höjdpositionen, håll in i 7 sekunder. När LED-skärmen "RST" och "E-1" blinkar växelvis, släpp "V"-tangenten och håll in tangenten igen. Efter att skrivbordet har sänkts till den lägsta mekaniska nollpunkten, gå tillbaka 5 mm. LED-skärmen visar det lägsta höjdvärdet och återställningen är klar.

### Ställ in minneshöjd + //

Tryck på S-tangenten en gång, och höjdvärdet börjar blinka. Vid detta tillfälle, tryck på tangenterna 1, 2 och 3 för att spara den aktuella höjden till motsvarande position.

### Utför minneshöjd

I normalt läge, tryck på nummerknappen för att hämta motsvarande höjd, och det lyftande bordet kommer automatiskt att gå till motsvarande position.

### Låstangent

Håll in S-tangenten i 3 sekunder. När LED-skärmen visar "SET", lär dig att öppna S-tangenten. Tryck på nummerknapp 3 för att gå in i låsskärmsläge. Vid detta tillfälle blinkar LED-skärmen och visar "OFF".

När skärmen är låst, håll in S-tangenten i 3 sekunder, och LED-skärmen visar höjdvärdet. Vid detta tillfälle, släpp S-tangenten för att slutföra upplåsningen.

### Återställ fabriksinställningar

Håll in S-tangenten i 9 sekunder, släpp S-tangenten när LED-skärmen visar "FAC", och tryck på S-tangenten igen för att återställa fabriksinställningarna.

## Felmeddelanden

Felkod	Orsak	Lösning
Err	Err visas när kommunikationslinjens sekvens mellan den manuella kontrollen och kontrollboxen är felaktig.	/
E-1	När systemet inte sparar den aktuella positionen blinkar LED-skärmen växelvis och visar "E-1".	Återställ genom att trycka länge på knappen tills LED-skärmen visar den minimi höjden och larmet släpps.
E-2	När motorn är låst visar LED-skärmen "E-2".	/
E-5	När motorn uppvisar: den anslutande linjen är kopplad från/lossnad, blinkar LED-skärmen växelvis och visar "E-5".	Kontrollera anslutningslinjerna mellan alla motorer och styrenheten för att säkerställa att de är fasta, och återställ sedan genom att trycka länge på ned-tangenten tills LED-skärmen visar den minimi höjden, och ta bort larmet.
ovr	När lasten överstiger det inställda värdet blinkar LED-skärmen och visar "ovr". Vid detta tillfälle måste vikten på skrivbordet tas bort och styrenheten slås på efter att ha stängts av. Detta larm kan lindras.	<ol style="list-style-type: none"> <li>1. Normal belastning ska kontrolleras under 120KG</li> <li>2. När strömmen överstiger 4A, kommer överbelastningsskyddsfunktionen att aktiveras.</li> </ol>
hot	När den interna temperaturen på styrenheten överstiger 60±5 grader, visar LED-skärmen "hot".	/
voL	När ingångsspänningen på styrenheten överstiger 34V, visar LED-skärmen "voL".	<ol style="list-style-type: none"> <li>1. När spänningen överstiger 32V stängs styrenheten av och LED-skärmen är svart;</li> <li>2. När spänningen sjunker till 32V, kommer systemet automatiskt att återupptas och LED kommer att visa den realtids höjden.</li> </ol>
hot	Efter att motorn har kört kontinuerligt i 5 minuter visar LED-skärmen "hot", och den kan fungera normalt efter att ha väntat i 10 minuter.	<ol style="list-style-type: none"> <li>1. Oavbruten drift innebär att driftintervallet är inom 3 sekunder.</li> <li>2. Detta larm kan också tas bort när styrenheten slås på igen.</li> </ol>
E-3	Under drift, när det plötsligt blockeras, blinkar LED-skärmen "E-3", stoppar åtgärden och kör 30 mm i motsatt riktning, sedan visar LED-skärmen den realtids höjden.	Det ska säkerställas att bordet inte vibrerar kraftigt, stöter emot hinder eller lutar under drift.

# Pakketinhoud

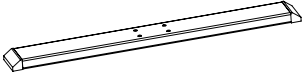

A x 2



B x 1



C x 1



D x 2

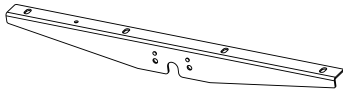

F x 2

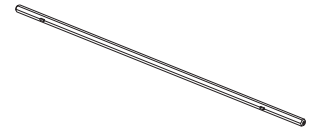

G x 1

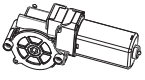

I x 1

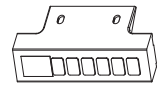

J x 1

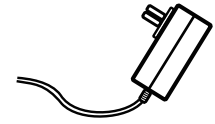

K x 1

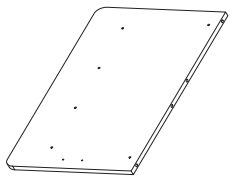

L x 1

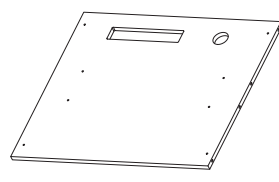

M x 1

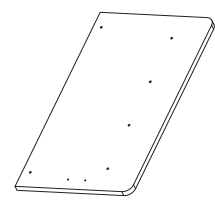

N x 1

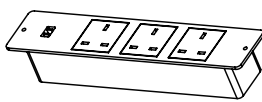

Y x 1

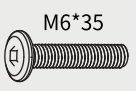

O x 8



P x 32

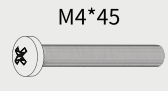

Q x 2



R x 2



S x 1

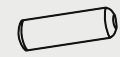

T x 8



U x 4

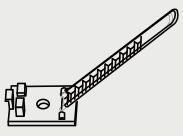

V x 2



W x 4



X x 2

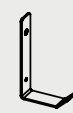

Z x 1

# 1 Voetinstallatie

Wanneer de grond oneffen is, kan de voetpad worden gedraaid om balans te bereiken.

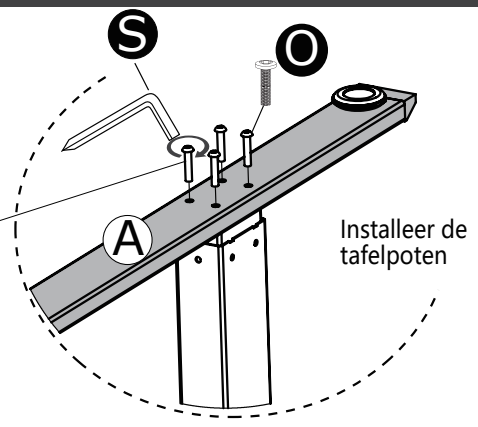
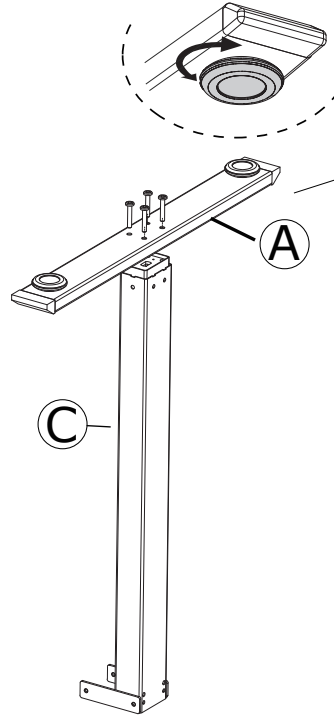
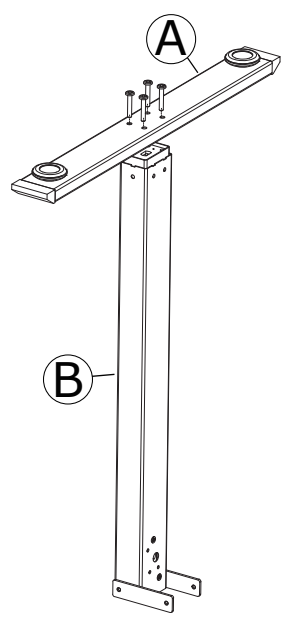

Installeer de tafelpoten

- A x 2
- B x 1
- C x 1

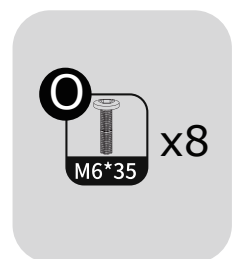

# 2 Installeer de motor

**Stap 1**

Steek de hexagonale staaf in het sleufgat van de motor in de richting van de pijl.

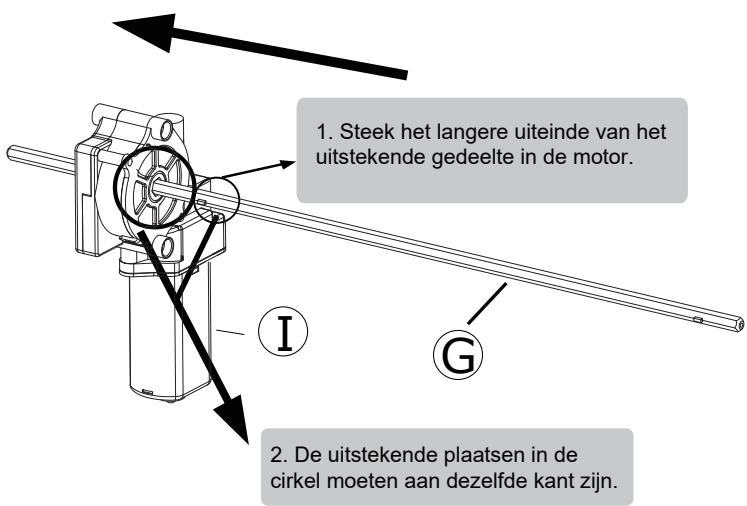

1. Steek het langere uiteinde van het uitstekende gedeelte in de motor.

2. De uitstekende plaatsen in de cirkel moeten aan dezelfde kant zijn.

**Stap 2**

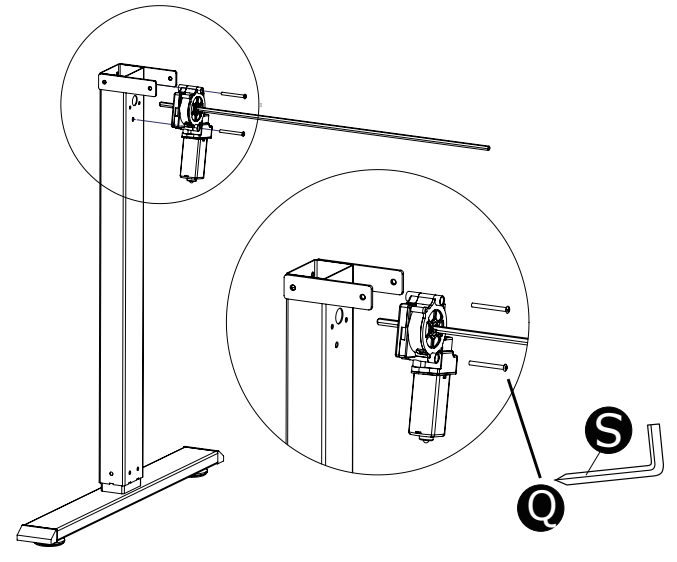

- I x 1
- G x 1

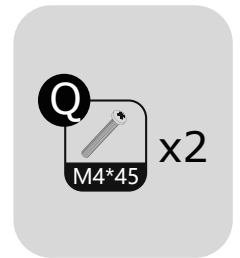

### 3 Aandrijfstanginstallatie - 1

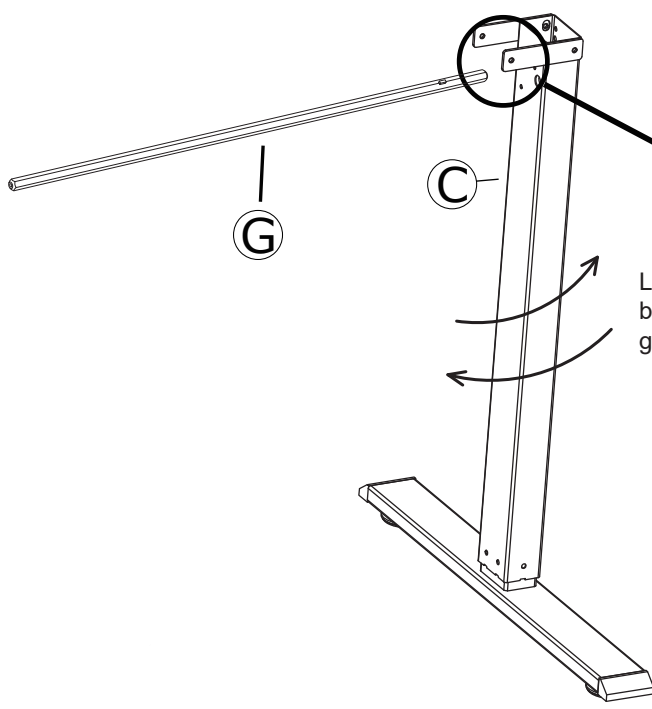

Steek het aan de ene kant in de versnellingsbak.

Lijn de motorstang uit met poot (C). Als de uitlijning onjuist is, beweeg de poot voorzichtig van links naar rechts om een goede pasvorm te bereiken.

G x 1

### 4 Aandrijfstanginstallatie - 2

Zoals weergegeven in de onderstaande afbeelding.

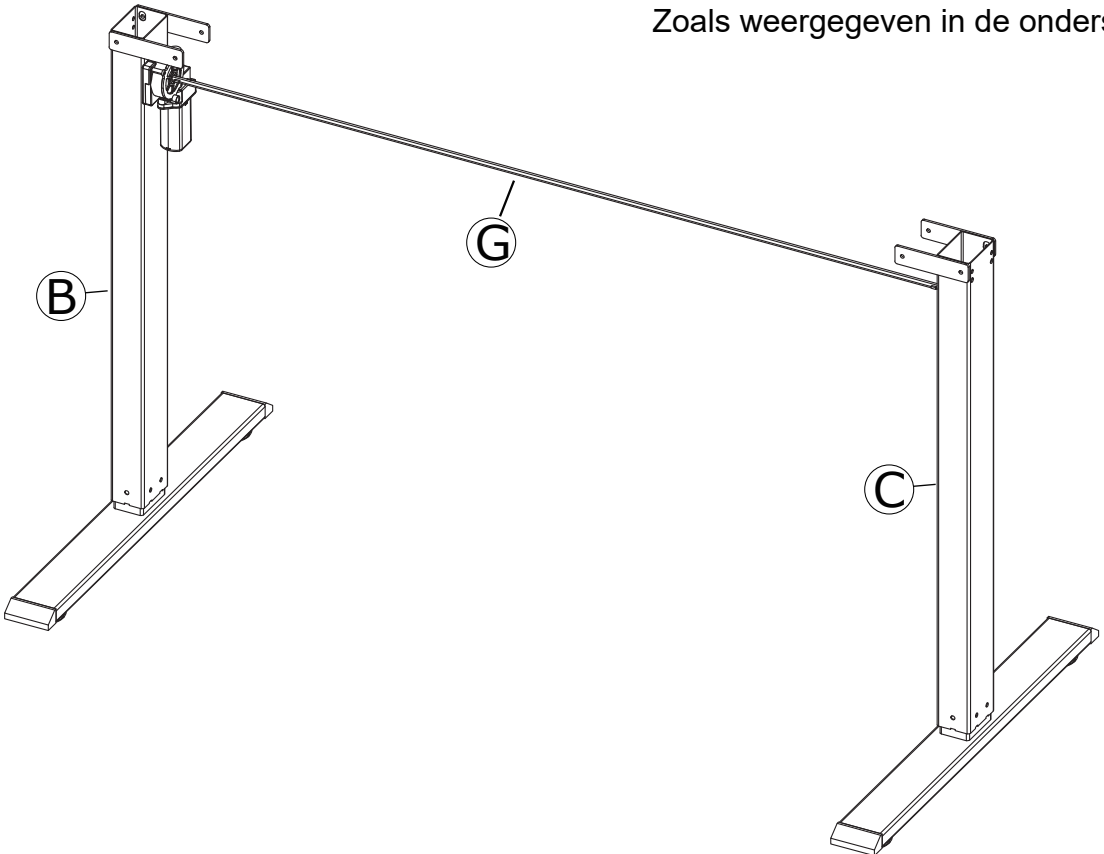

5 Balkinstallatie

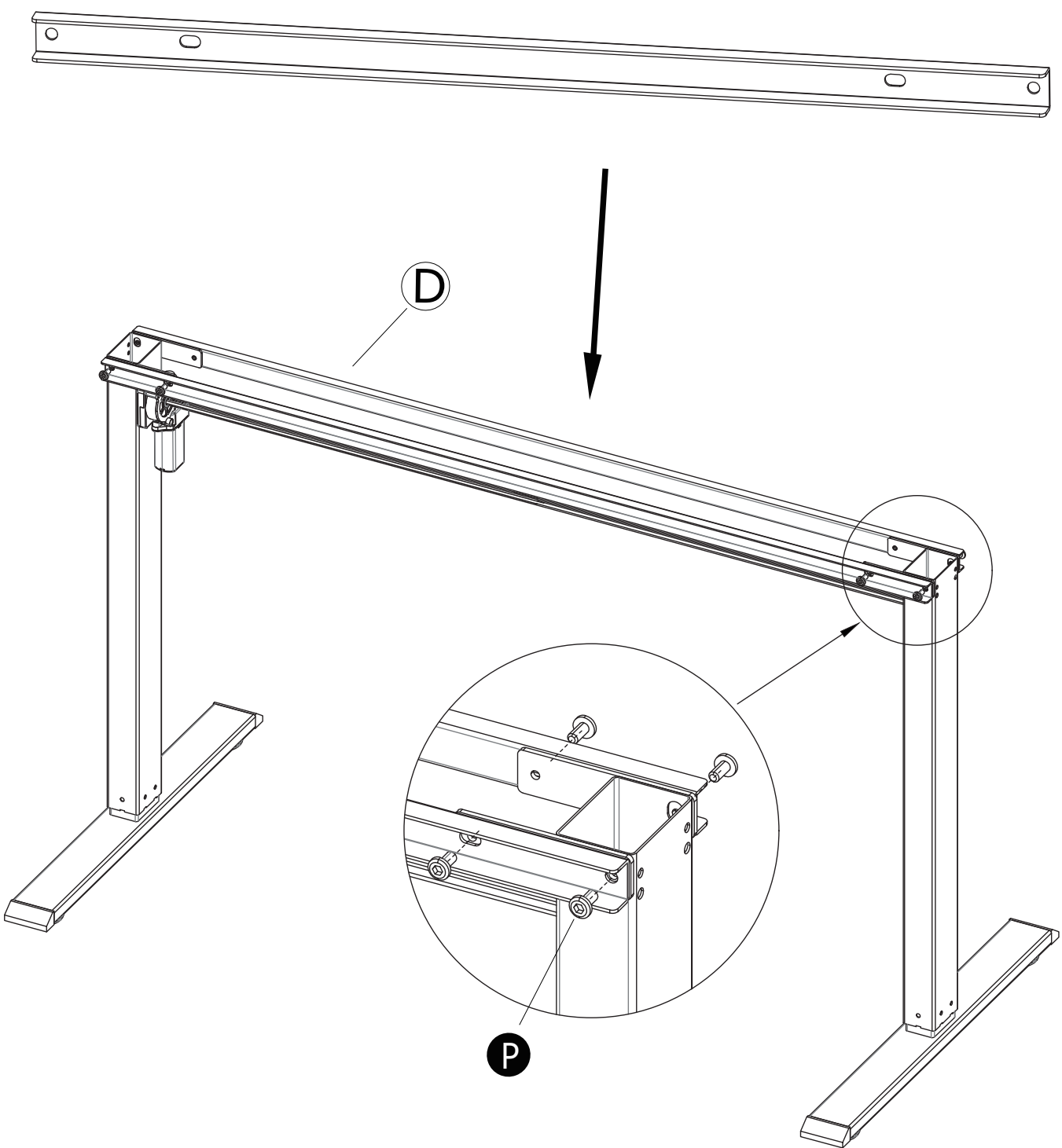

D x 2

P  
M6\*12 x8

## 6 Zijvleugelinstallatie

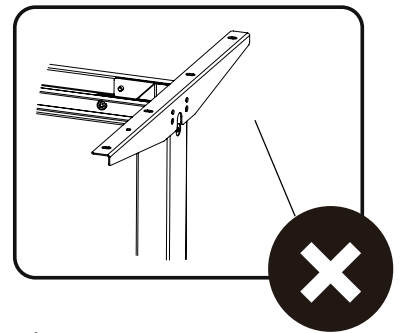
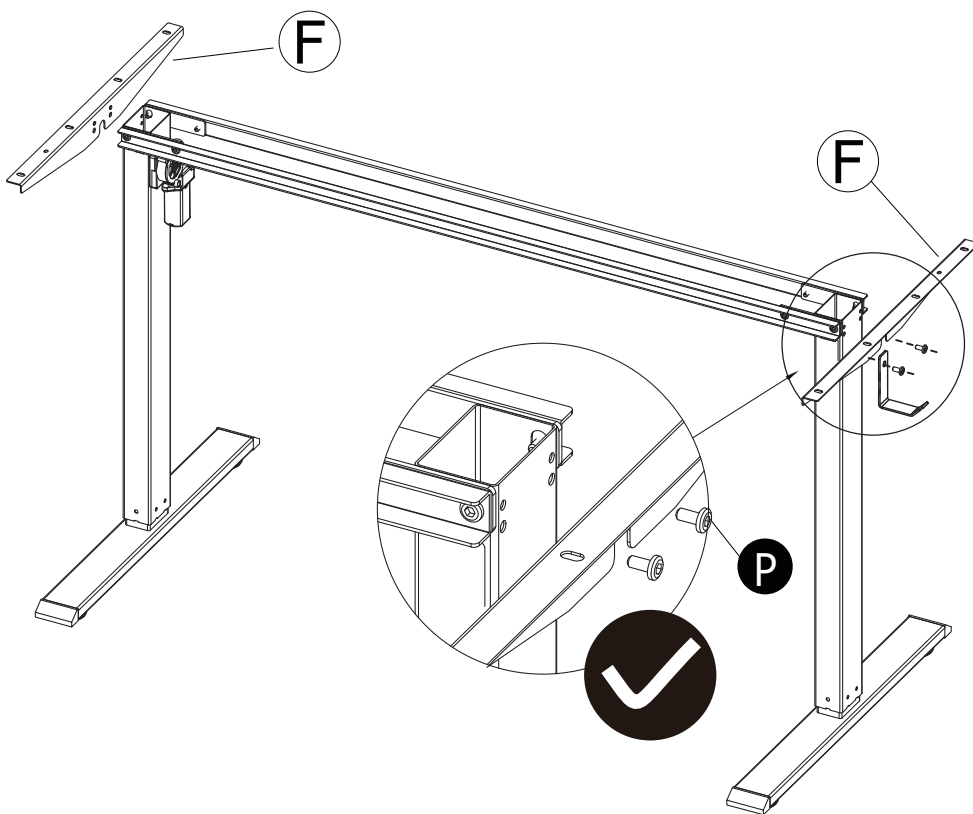

⚠️ Onjuiste demonstratie

F x 2  
Z x 1

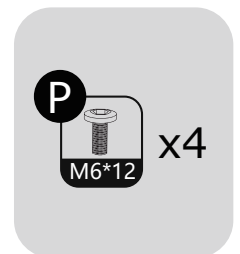

## 7 Paneelinstallatie - 1

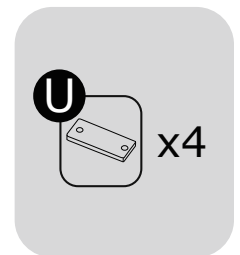
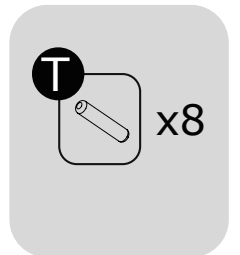
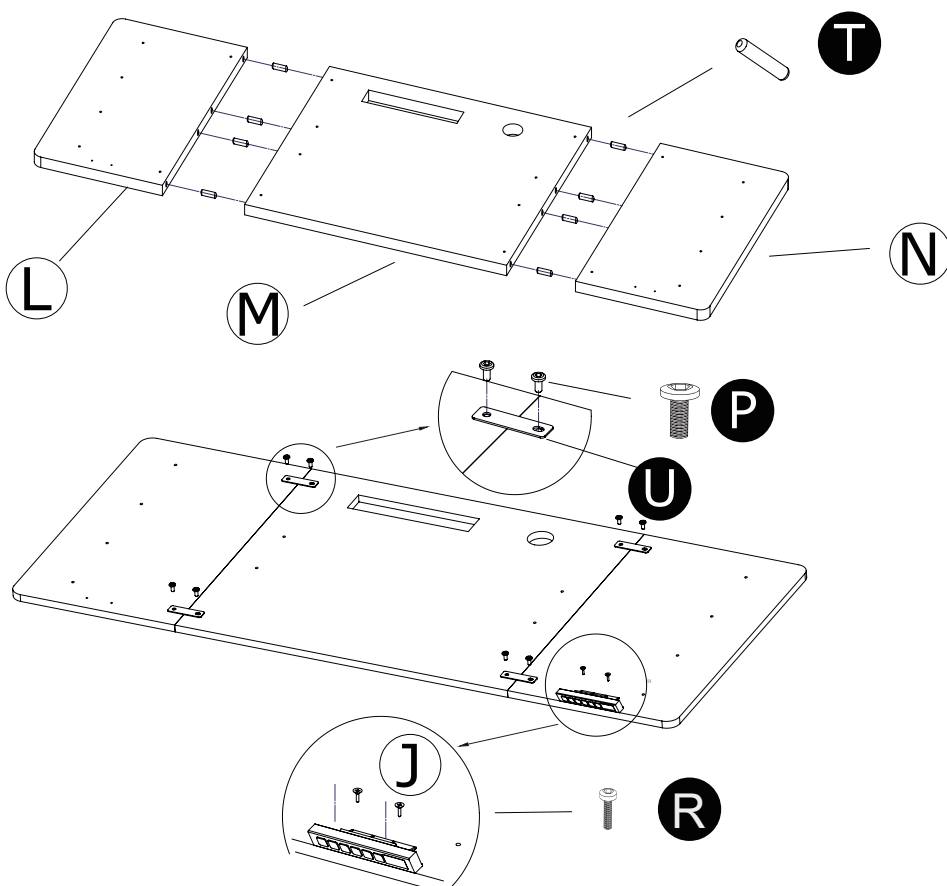

J x 1  
L x 1  
M x 1  
N x 1

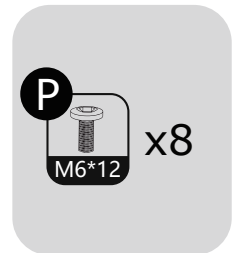
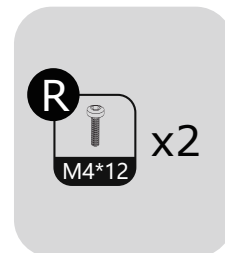

# 8 Paneelinstallatie - 2

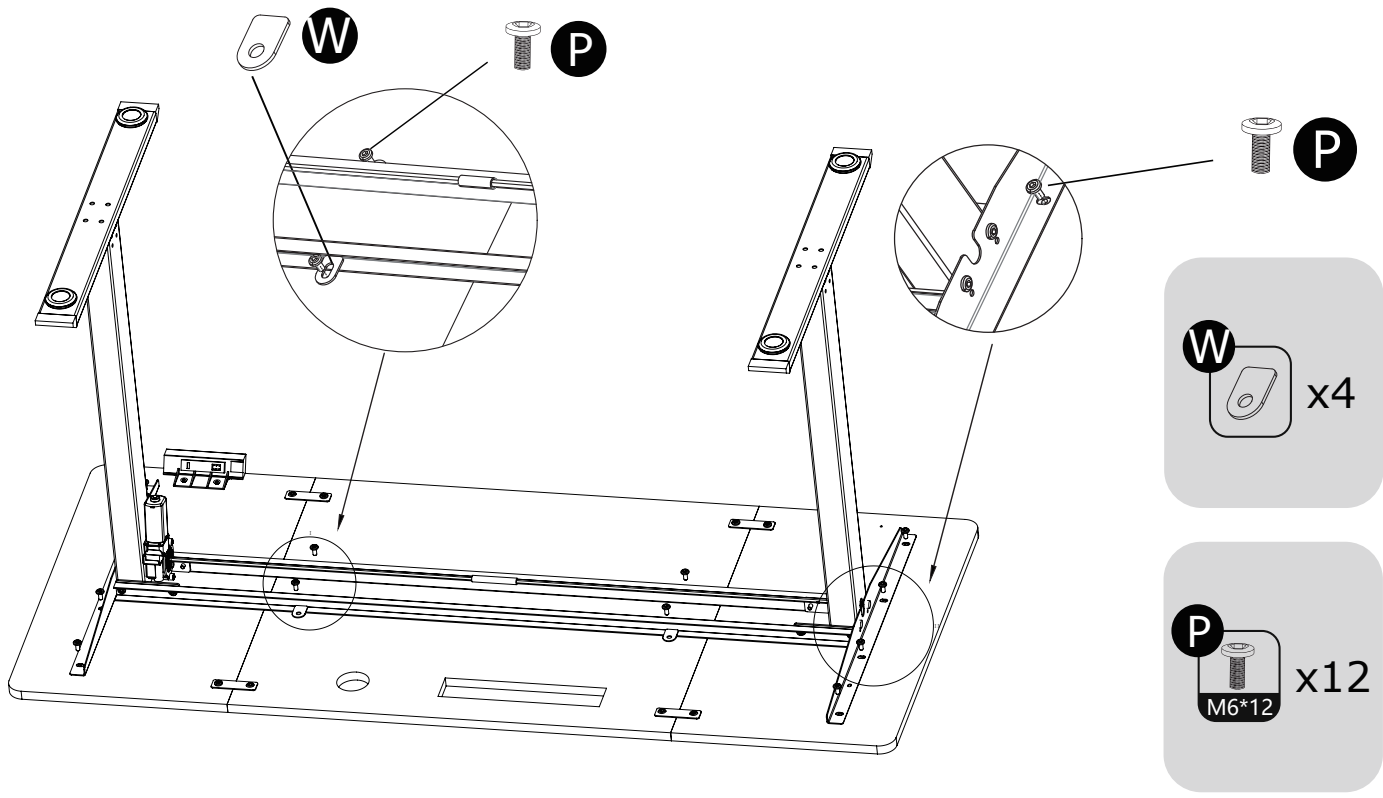

# 9 Draadverbinding

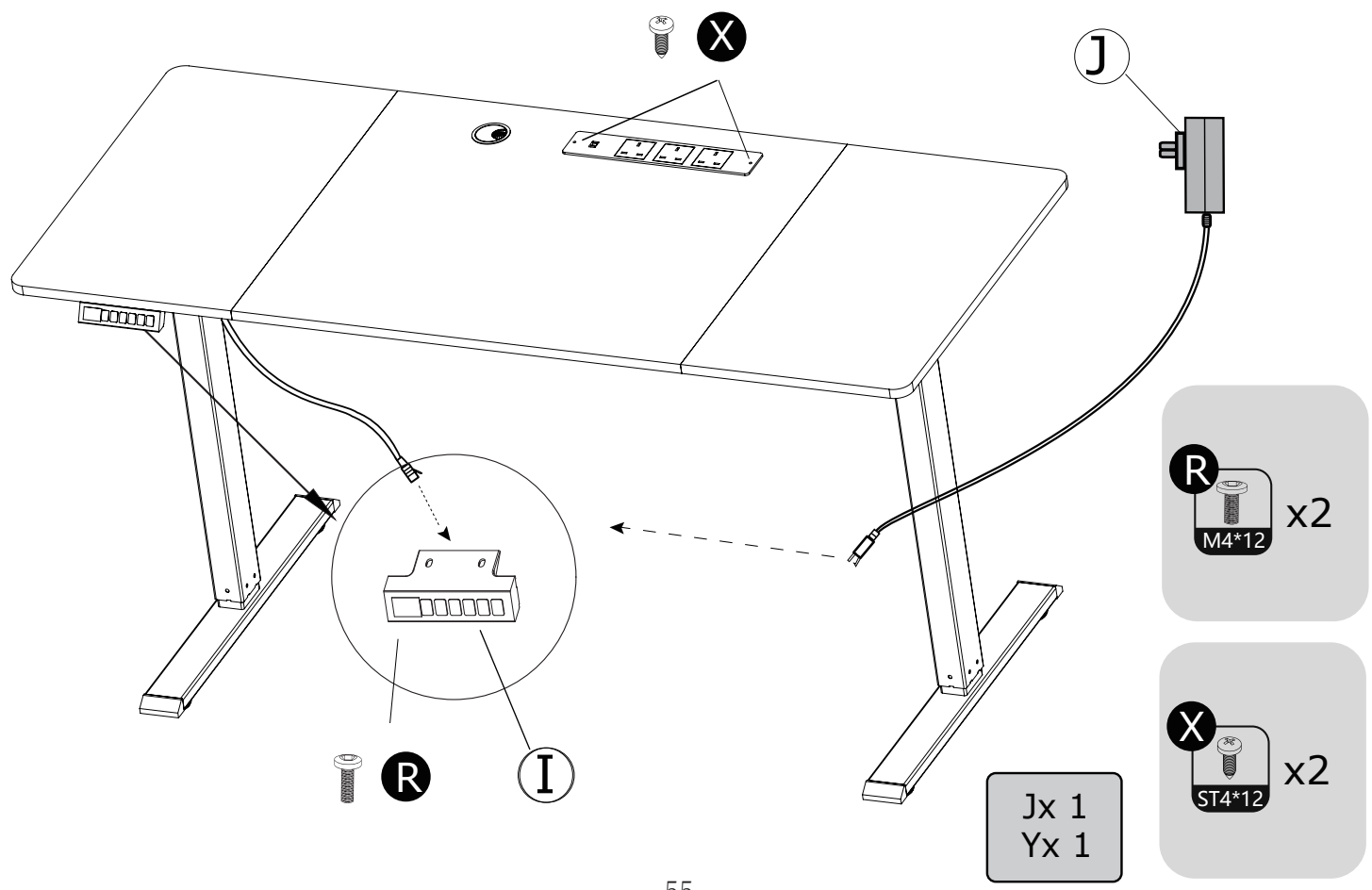

## Bediening van de hoogte-instelling controller

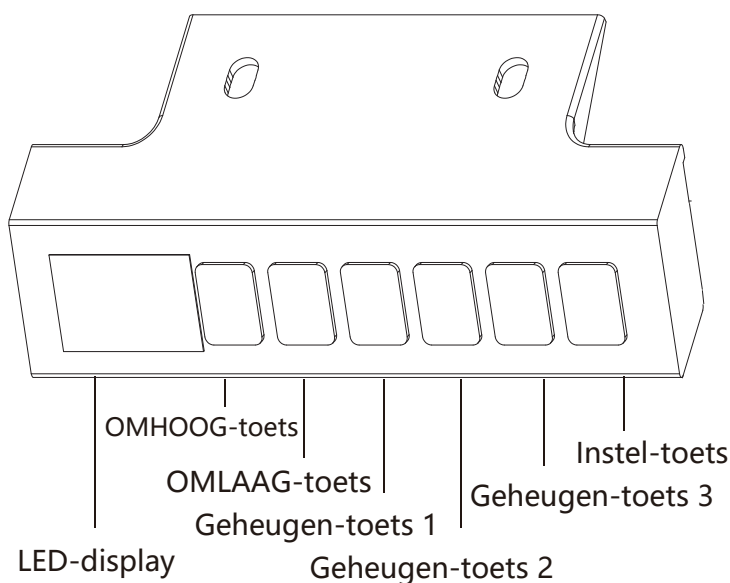

### • LED-display:

Druk één keer op een toets om het LED-display te activeren.

### • OMHOOG-toets:

Druk en houd de OMHOOG-toets ingedrukt om het bureau te verhogen.

### • OMLAAG-toets:

Druk en houd de OMLAAG-toets ingedrukt om het bureau te verlagen.

### • Geheugen-toets:



U moet het initialisatieproces voltooien om uw bureau opnieuw in te stellen voordat u het voor de eerste keer gebruikt.



Wanneer het display "E-1" of "RST" weergeeft, betekent dit dat een reset-operatie aan de gang is. Blijf de OMLAAG-toets "V" ingedrukt houden zoals vereist in de gebruiksaanwijzing totdat de minimale hoogtewaarde verschijnt en laat dan de toets los.

## Gedetailleerde introductie van toetsfuncties

### Reset

Nadat het bureau naar de laagste hoogte is gegaan, druk en houd deze 7 seconden ingedrukt. Wanneer het LED-scherm "RST" en "E-1" om en om knippert, laat de "V"-toets los en houd de toets opnieuw ingedrukt. Nadat het bureau naar het laagste mechanische nulpunt is gedaald, gaat het 5 mm omhoog, het LED-scherm geeft de laagste hoogtewaarde weer en de reset is voltooid.

### Geheugenhoogte instellen + / /

Druk eenmaal op de S-toets, en de hoogtewaarde begint te knipperen. Druk nu op de toetsen 1, 2 en 3 om de huidige hoogte op de bijbehorende positie op te slaan.

### Geheugenhoogte uitvoeren

In normale toestand drukt u op de nummer-toets om de bijbehorende hoogte op te roepen, en het verstelbare bureau zal automatisch naar de bijbehorende positie gaan.

### Vergrendeltoets

Druk en houd de S-toets 3 seconden ingedrukt. Wanneer het LED-scherm "SET" weergeeft, leert u om de S-toets te openen. Druk op de nummer-toets 3 om de vergrendelingsstatus in te voeren. Op dit moment knippert het LED-scherm en geeft "OFF" weer.

Wanneer het scherm is vergrendeld, druk en houd de S-toets 3 seconden ingedrukt, en het LED-scherm toont de hoogtewaarde. Laat op dit moment de S-toets los om het ontgrendelen te voltooien.

### Fabrieksinstellingen herstellen

Houd de S-toets 9 seconden ingedrukt, laat de S-toets los wanneer het LED-scherm "FAC" weergeeft, en bedien de S-toets opnieuw om de fabrieksinstellingen te herstellen.

## Foutcode-instructies

Foutcode	Reden	Oplossing
Err	Err wordt weergegeven wanneer de volgorde van de communicatieverbinding tussen de handbediening en de controlekast onjuist is.	/
E-1	Wanneer het systeem de huidige positie niet opslaat, knippert het LED-scherm afwisselend en toont "E-1".	Reset door de lange toets ingedrukt te houden totdat het LED-scherm de minimale hoogte weergeeft en het alarm wordt opgeheven.
E-2	Wanneer de motor is vergrendeld, geeft het LED-scherm "E-2" weer.	/
E-5	Wanneer de motor verschijnt: de verbindinglijn is losgekoppeld of los, knippert het LED-scherm afwisselend en toont "E-5".	Controleer de verbindinglijnen tussen alle motoren en de controller om ervoor te zorgen dat ze stevig zijn, en reset vervolgens door de OMLAAG-toets lang ingedrukt te houden totdat het LED-scherm de minimale hoogte weergeeft en het alarm wordt opgeheven.
ovr	Wanneer de belasting de ingestelde waarde overschrijdt, knippert het LED-scherm en toont "ovr". Op dit moment is het nodig om het gewicht van het bureau te verwijderen en de controller opnieuw van stroom te voorzien nadat deze is uitgeschakeld. Dit alarm kan worden verlicht.	<ol style="list-style-type: none"> <li>1. Normale belasting moet onder de 120 KG worden gehouden.</li> <li>2. Wanneer de stroom 4A overschrijdt, wordt de overbelastingsbeveiligingsfunctie geactiveerd.</li> </ol>
hot	Wanneer de interne temperatuur van de controller $60\pm 5$ graden overschrijdt, geeft het LED-scherm "hot" weer.	/
voL	Wanneer de invoerspanning van de controller 34V overschrijdt, geeft het LED-scherm "voL" weer.	<ol style="list-style-type: none"> <li>1. Wanneer de spanning 32V overschrijdt, wordt de controller uitgeschakeld en is het LED-scherm zwart;</li> <li>2. Wanneer de spanning daalt tot 32V, zal het systeem automatisch reageren en geeft het LED-scherm de real-time hoogte weer.</li> </ol>
hot	Nadat de motor 5 minuten continu heeft gedraaid, geeft het LED-scherm "hot" weer en kan deze normaal functioneren na 10 minuten wachten.	<ol style="list-style-type: none"> <li>1. Ononderbroken werking betekent dat het werkinterval binnen de 3 seconden ligt.</li> <li>2. Dit alarm kan ook worden verwijderd wanneer het controlesysteem opnieuw wordt ingeschakeld.</li> </ol>
E-3	Tijdens de werking, wanneer het plotseling wordt geblokkeerd, knippert het LED-scherm "E-3", stopt de actie en draait 30 mm in de tegenovergestelde richting, waarna het LED-scherm de real-time hoogte weergeeft.	Er moet voor worden gezorgd dat de tafel tijdens de werking niet significant trilt, tegen obstakels botst of kantelt.