

## INSTALLATION GUIDE

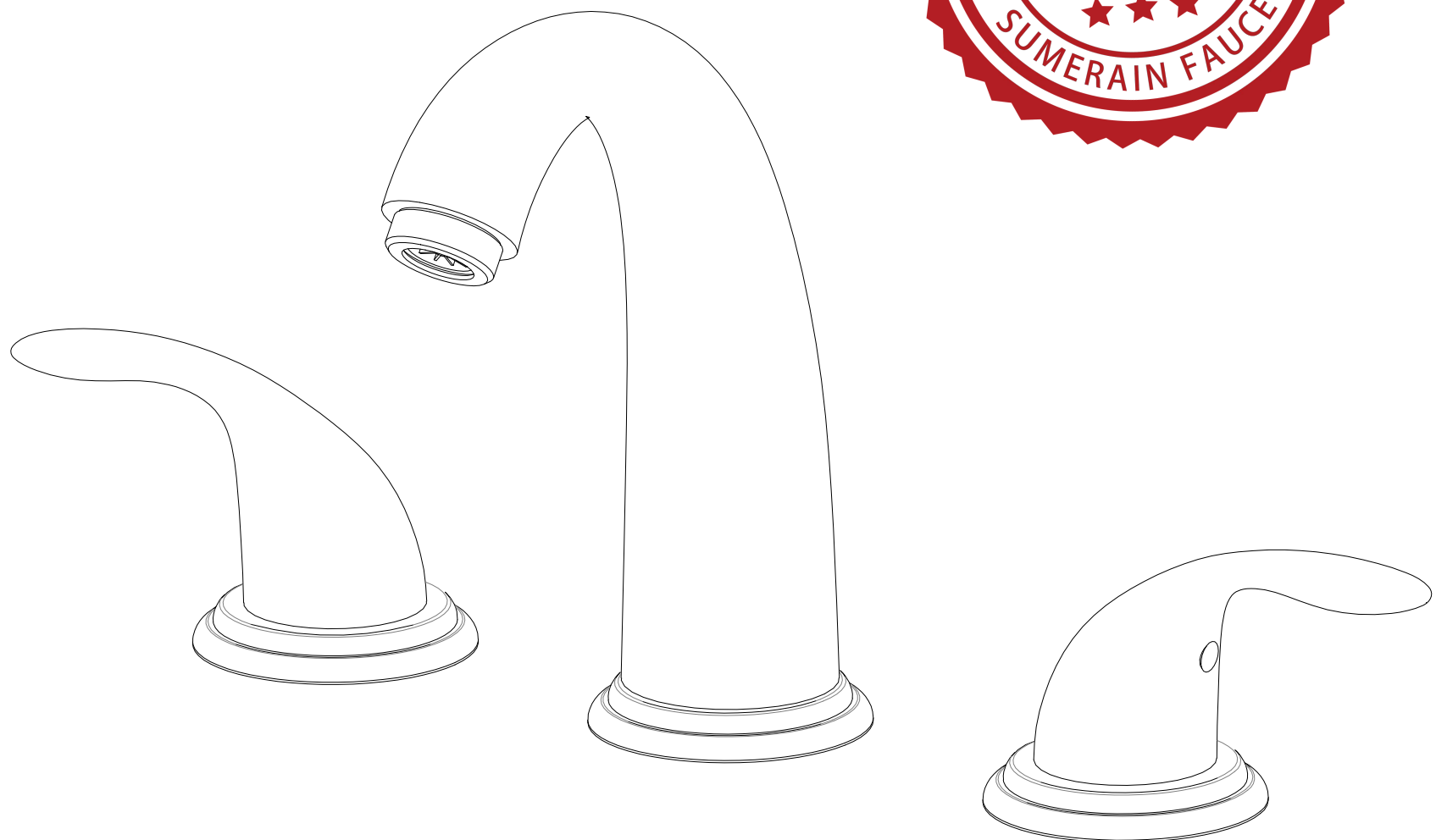

### ROMAN BATHTUB FAUCET

MODEL	FINISH
S2142CS	CHROME
S2142NS	BRUSHED NICKEL
S2142DS	MATTE BLACK
S2142BGS	BRUSHED GOLD

**HOT LINE: +1-866-203 0866**

## THANK YOU

Dear Valued Customer,

Thank you for choosing SUMERAIN products. We would like to take this opportunity to express our sincere gratitude for your recent purchase. We hope you are completely satisfied with your new product. Rest assured, we meticulously engineer all SUMERAIN products and put them through rigorous factory tests to ensure their prolonged, trouble-free use under normal conditions.

Installing this product is as simple as it gets. All you need are some basic tools and our handy step-by-step illustrated guide. We wholeheartedly welcome any questions or feedback you may have. We eagerly anticipate the opportunity to assist you in the future. If you have any inquiries regarding this product, please do not hesitate to contact us at +1-866-203-0866 or email us at [supports@sumerain.com](mailto:supports@sumerain.com).

Once again, we extend our gratitude for selecting SUMERAIN products. We remain committed to providing exceptional customer service.

Sincerely,

SUMERAIN Customer Service Department

## BEFORE PROCEEDING

1. Unpack your new product and verify that all components are present in the package. Until you're ready to install, it's best to keep the product in its original box.
2. Identify the water supply inlets and turn off the water supply valves. You'll typically find these valves near the water meter. If you're replacing an existing unit, make sure to remove the old one and clean the mounting surface thoroughly.
3. Adhere to all plumbing and building codes applicable in your area.
4. If you're not confident about installing the product yourself, we strongly recommend seeking help from a professional.

## TOOLS RECOMMENDED

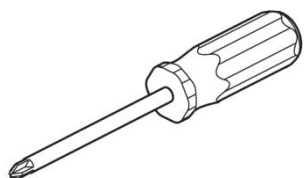

Philips screwdriver

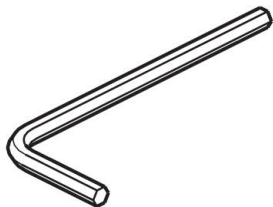

Allen wrench

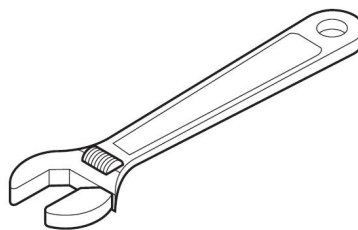

Adjustable wrench



Channel locks



Teflon tape

# LIMITED LIFETIME CONSUMER WARRANTY

**VERSION: 140320.15.5**

This product has been manufactured and tested to the highest quality standards by HONGKONG SUMERAIN SANITARY INDUSTRY Co., Limited ("SUMERAIN"). This warranty applies solely to SUMERAIN products purchased by consumers in the United States after January 1st, 2020. In the event of a faucet experiencing leaks or drips during regular usage, SUMERAIN will provide the necessary faucet cartridge to the purchaser, free of charge, in order to restore the faucet to proper working condition. If any defects are identified during normal residential use, SUMERAIN will, at its discretion, perform repairs, provide replacement parts or products, or make appropriate adjustments to ensure the product's optimal functionality.

## **WHO IS COVERED BY THE WARRANTY**

This warranty provides exclusive coverage to the original consumer purchaser, including those who have made purchases through online retail platforms. However, online retail customers who are specifically covered by the "Online CONSUMER Limited Lifetime WARRANTY & Return policy" are also included. Please note that this warranty is non-transferable and cannot be assigned to any other party.

## **WHAT IS COVERED BY THE WARRANTY**

This warranty is applicable only to the SUMERAIN manufactured product that you have purchased. SUMERAIN provides the following warranty against defects in material or workmanship: under normal installation, use, service, and maintenance, if the product or any of its components prove to be defective due to improper workmanship or materials, SUMERAIN will, at its discretion, provide free replacement parts or replace the entire product.

## **FINISH WARRANTY**

Customers are responsible for thoroughly inspecting the product for any material or finish defects within three days of receiving it. Please note that SUMERAIN does not cover surface finish defects under warranty once the fixture has been installed.

## **ELECTRONIC FAUCETS WARRANTY**

SUMERAIN guarantees its LED components, including electronic faucets, valves, controllers, and battery-powered devices, against material and manufacturing defects for one year from the date of purchase, under normal use. The water flow impeller power device (LED faucet power generation device) is guaranteed to be free from manufacturing defects for the first three months from the date of purchase.

## **LENGTH OF WARRANTY**

As stated in the following, any replacement or repaired parts of the product will be covered for the duration of this warranty, which SUMERAIN provides for a period of 1 year from the original date of purchase.

## **CIRCUMSTANCES THAT SUMERAIN WILL NOT WARRANT AND PAY FOR:**

- A. Conditions, malfunctions, or damage that do not result from defects in material or workmanship.
- B. Conditions, malfunctions, or damage resulting from normal wear and tear, improper installation, improper maintenance, misuse, abuse, negligence, accidents, alterations, or the use of abrasive or caustic cleaning agents, "no-rinse" cleaning products, or the product in a manner contrary to the provided instructions. This includes home conditions such as excessive water pressure or corrosion.
- C. Labor or other expenses associated with disconnection, deinstallation, or return of the product for warranty service, as well as installation or reinstallation of the product.
- D. Accessories, connected materials, and products (including but not limited to hand shower flexible hose, spray flexible hose, hand shower, shower head), or related products that are not manufactured by SUMERAIN.

## **TO OBTAIN WARRANTY PARTS OR INFORMATION**

To obtain warranty parts or information professionally, please follow the steps below:

Contact your SUMERAIN retailer or dial the technical service phone number at +1-866-203-0866, or send an email to [supports@sumerain.com](mailto:supports@sumerain.com). When applying for warranty service, you will need to provide the following information:

- a. Sales receipt or other evidence of purchase date and platform.
- b. Detailed description of the problem.
- c. Ship the product or defective parts to the designated Sumerain warehouse in the United States with prepaid postage. Please ensure careful packaging and insurance of the items. Once the warranty service is completed, any repaired or replaced products or parts will be shipped back to you with prepaid postage.

If you have any further questions or need additional assistance, please contact the provided contact information.

## **EXCLUSIONS & LIMITATIONS**

Pursuant to the terms of this warranty, repair, replacement (or, in limited circumstances, refund of the purchase price) shall be the sole remedy available to the purchaser. SUMERAIN assumes no obligations or liabilities and does not authorize any individual to create obligations or liabilities in relation to this product. SUMERAIN shall not be held liable to the purchaser or any party for any incidental, special, or consequential damages resulting from a breach of this warranty or any implied warranties (including merchantability). Please note that certain states do not allow the exclusion or limitation of incidental or consequential damages, therefore the aforementioned limitation or exclusion may not apply to you. This warranty grants you specific legal rights, and you may also have additional rights that vary from state to state. Before initiating any legal proceedings against us under the Magnuson-Moss Warranty Act, you may be legally required to provide us with a reasonable opportunity to rectify or resolve any non-compliance.

## **PRODUCT INSTRUCTIONS & QUESTIONS**

Prior to installation, we strongly recommend conducting a meticulous inspection of your SUMERAIN product to identify any potential damage or visible defects. It is crucial to thoroughly review the accompanying instructions regarding the correct installation, maintenance, and care procedures for the product. Should you have any inquiries regarding the utilization, installation, performance, or this warranty of your SUMERAIN product, please don't hesitate to reach out to us at +1-866-2030-866 or via email at [supports@sumerain.com](mailto:supports@sumerain.com). Our dedicated team is readily available to provide professional assistance and address any concerns you may have.

## FUNCTIONS AND SPECIFICATIONS

<b>Faucet Type</b>	Bathtub Faucet
<b>Feature</b>	Roman Tub Faucet
<b>Theme</b>	Contemporary
<b>Finish</b>	Chrome / Brushed Nickel / Matte Black / Brushed Gold
<b>Installation Type</b>	Deck Mounted
<b>Faucet Holes</b>	Three
<b>Handle Type</b>	Knob
<b>Number of Handles</b>	Two
<b>Spout Total Height</b>	6-11/16 in. [170 mm]
<b>Spout Reach</b>	4-29/32 in. [124 mm]
<b>Spout Width</b>	1-13/16 in. [46 mm]
<b>Spout Height</b>	5-1/8 in. [130 mm]
<b>Max Deck Thickness</b>	1-1/4 in. [32 mm]
<b>Valve Type</b>	Ceramic Disc
<b>Valve Body Material</b>	Brass
<b>Spout Material</b>	Brass
<b>Net Weight</b>	4.18 lbs [1.9 kg ]
<b>Gross Weight</b>	5.07 lbs [2.3 kg ]
<b>Working Water Pressure</b>	29 ~ 116 PSI [0.2 ~ 0.8 Mpa]
<b>Spout Flow Rate</b>	12.0 GPM [45 L/M ]@60PSI
<b>Packing Box</b>	14-9/16 in. [370 mm] x 8-27/32 in. [224 mm] x 2-3/4 in. [70 mm]

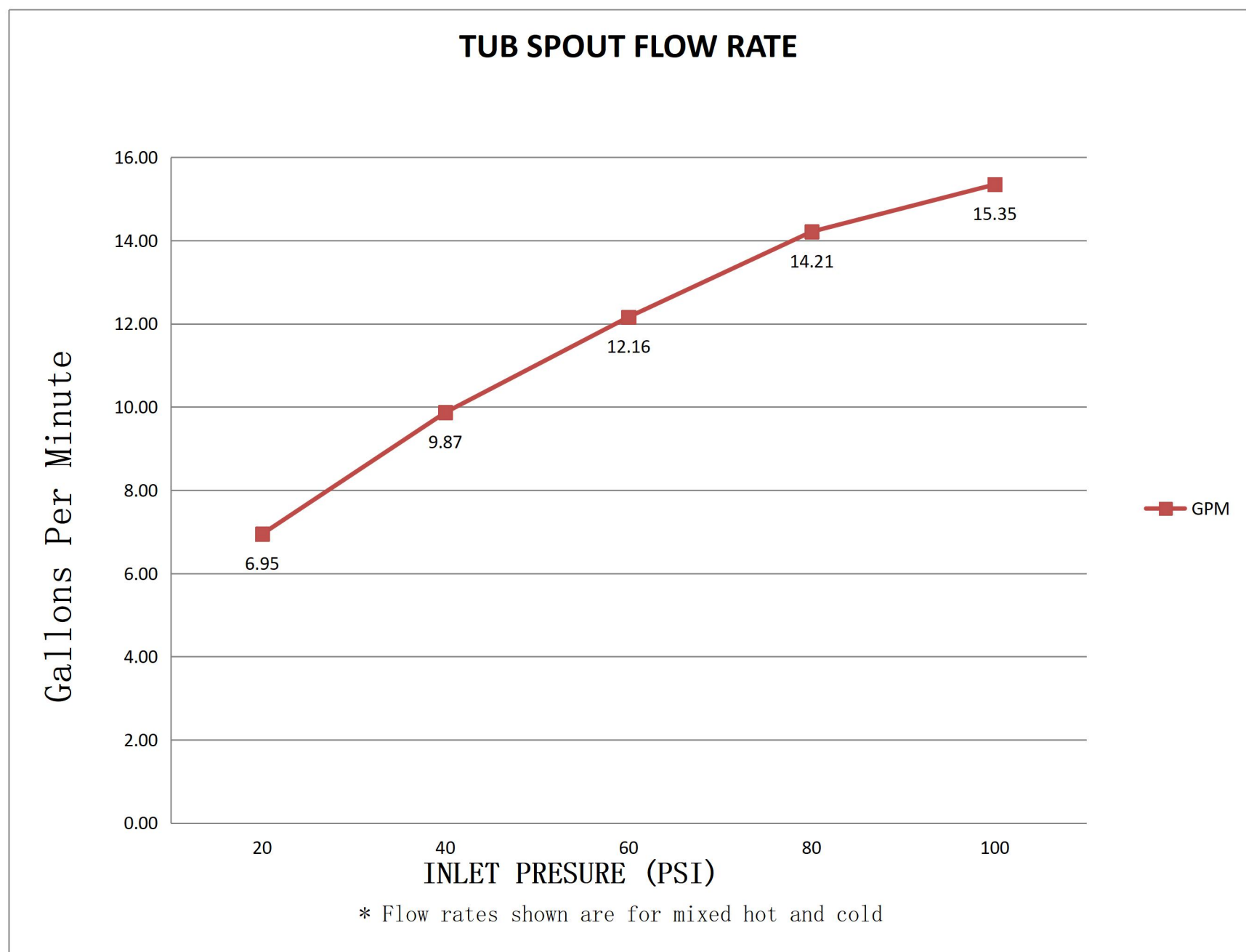

# DIMENSION

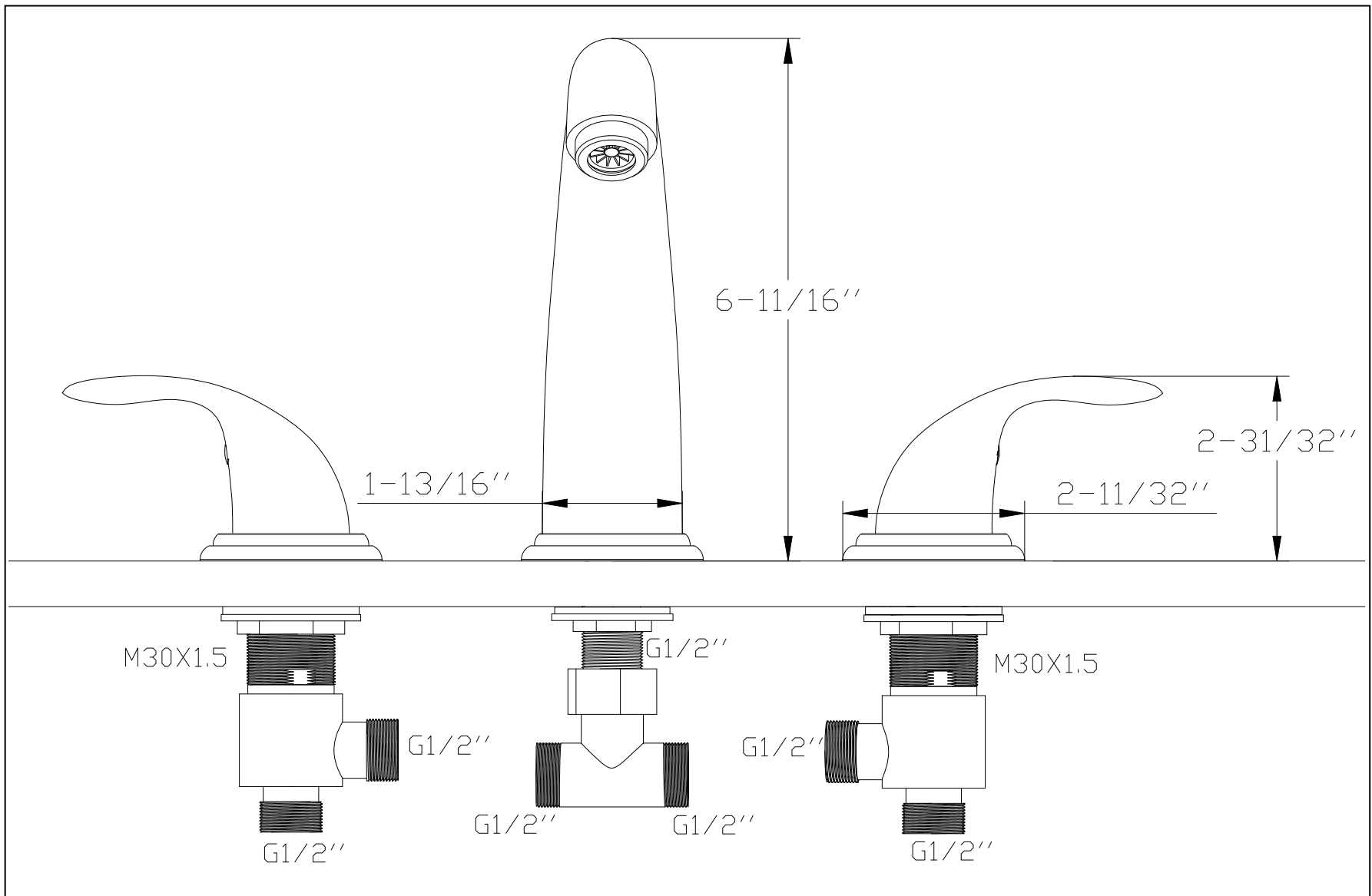

Front View

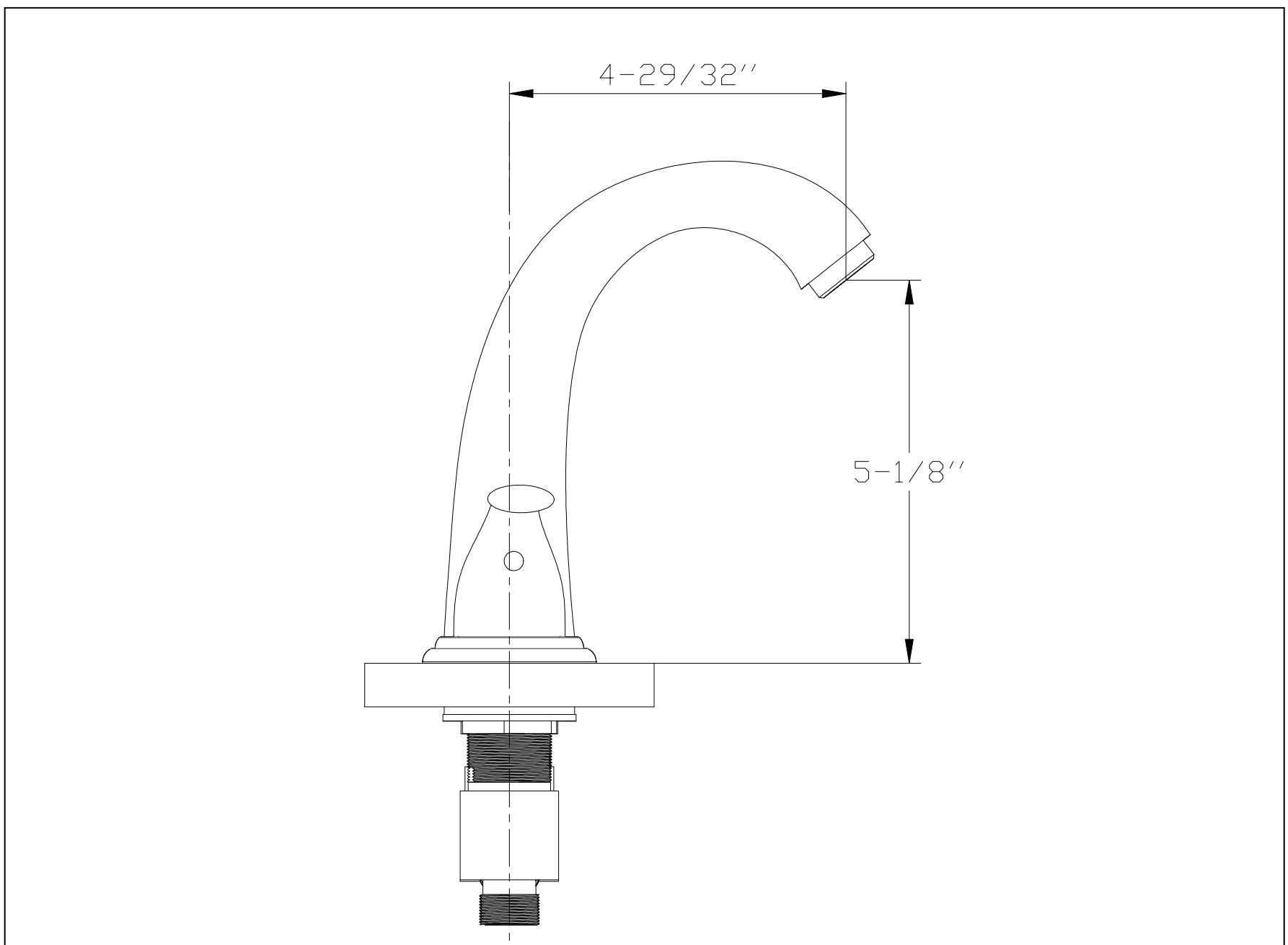

Side View

# INSTALLATION STEPS

## 1. BEFORE PROCEEDING



**WARNING:** Before proceeding with any operation, please read all instructions thoroughly. If you are uncertain about installing this product, please consult a professional! This product should be installed in accordance with all local and state plumbing and building codes. It is recommended to seek professional assistance.

## 2. SHUT OFF WATER SUPPLY

Locate the water supply inlets and shut off the corresponding water supply valves, typically found near the water meter. If replacing an existing unit, remove the old unit and thoroughly clean the mounting surface.

## 3. CHECK THE COMPONENTS OF THE BOX

Upon opening the box, verify the presence of the following items. If any of these items are missing, please contact SUMERAIN consumer service via email: [supports@sumerain.com](mailto:supports@sumerain.com).

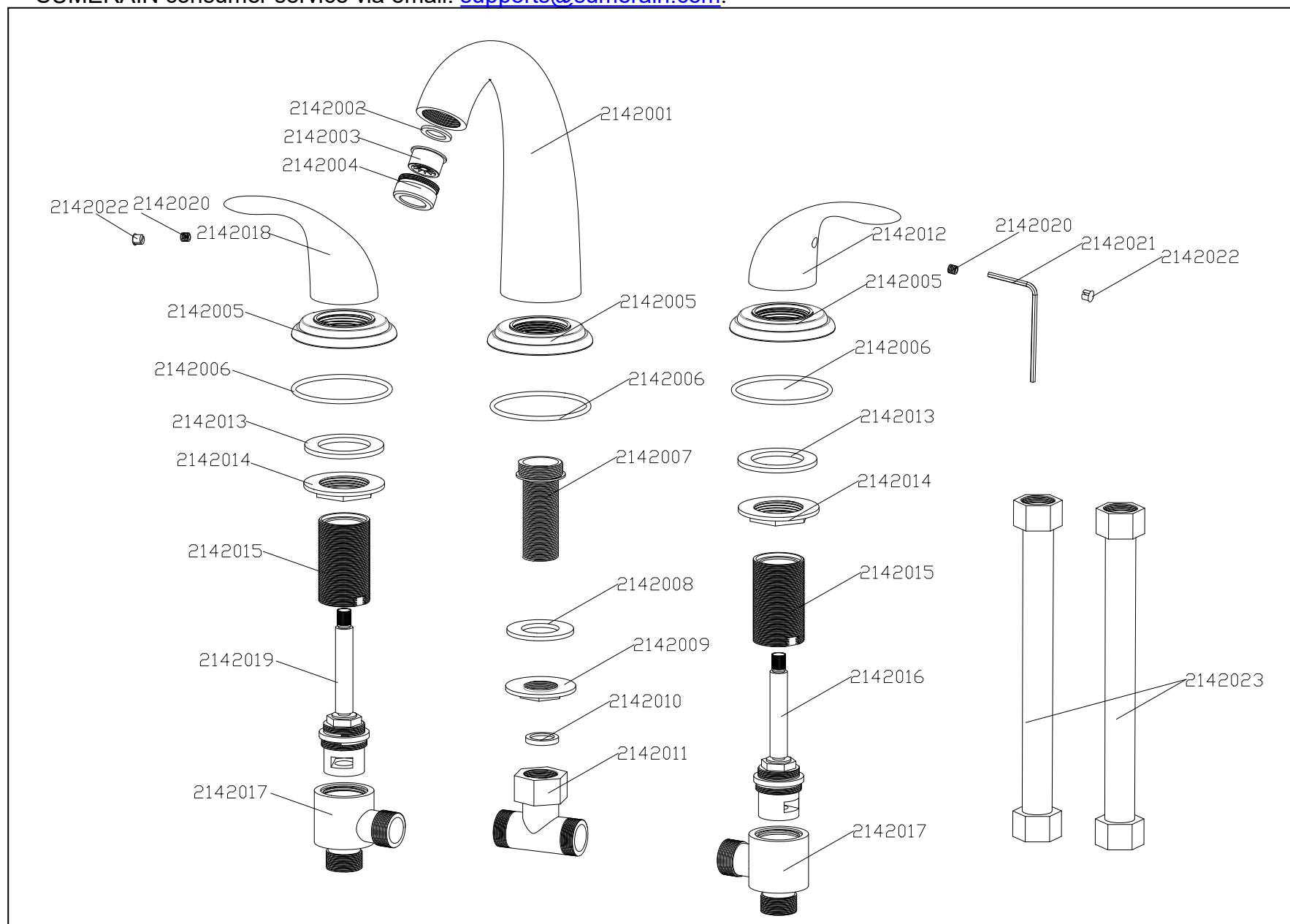

CODE	ITEM NAME	QTY	CODE	ITEM NAME	QTY
2142001	Spout	1PCS	2142002	Rubber washer	1PCS
2142003	Stream Shaper	1PCS	2142004	Aerator Nut	1PCS
2142005	Escutcheon	3PCS	2142006	O-Ring	3PCS
2142007	Spout shank	1PCS	2142008	Rubber washer	1PCS
2142009	G1/2" Lock Nut	1PCS	2142010	Rubber washer	1PCS
2142011	T-tee	1PCS	2142012	Handle(Cold)	1PCS
2142013	Rubber washer	2PCS	2142014	Lock Nut	2PCS
2142015	Cartridge Sleeve	2PCS	2142016	Cold disc cartridge	1PCS
2142017	Valve body	2PCS	2142018	Handle(Hot)	1PCS
2142019	Hot disc cartridge	1PCS	2142020	Screw cover	2PCS
2142021	Allen wrench	1PCS	2142022	Screw nut	2PCS
2142023	G1/2" hose(300mm)	2PCS			

#### 4. INSTALLATION HOLES INSPECTION

Please verify that the sizes and positions of the holes in the wall are correct. The optimal diameter for the mounting hole is ideally 1-1/4 inches, and the maximum thickness of the deck should not exceed 1-1/4 inches .

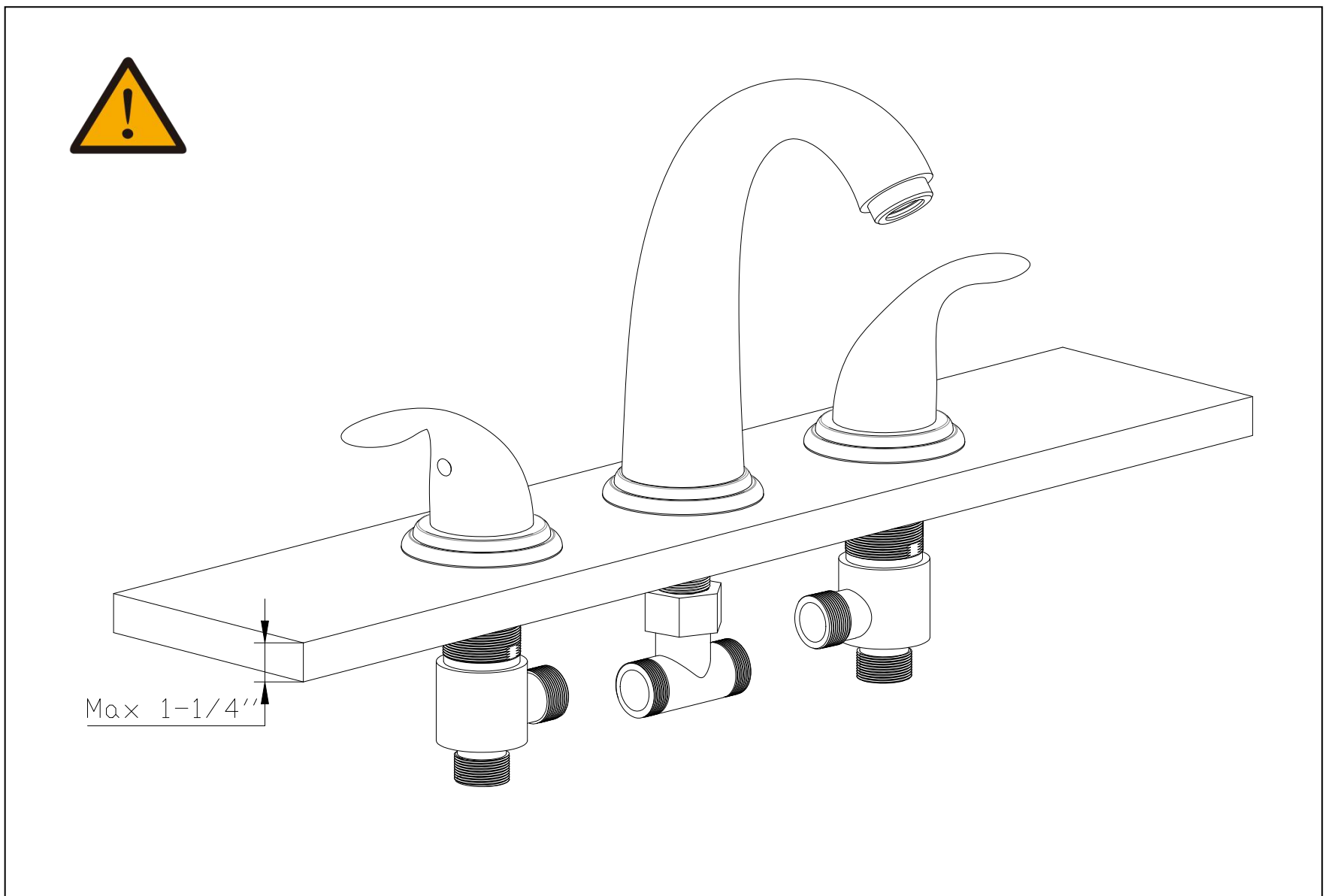
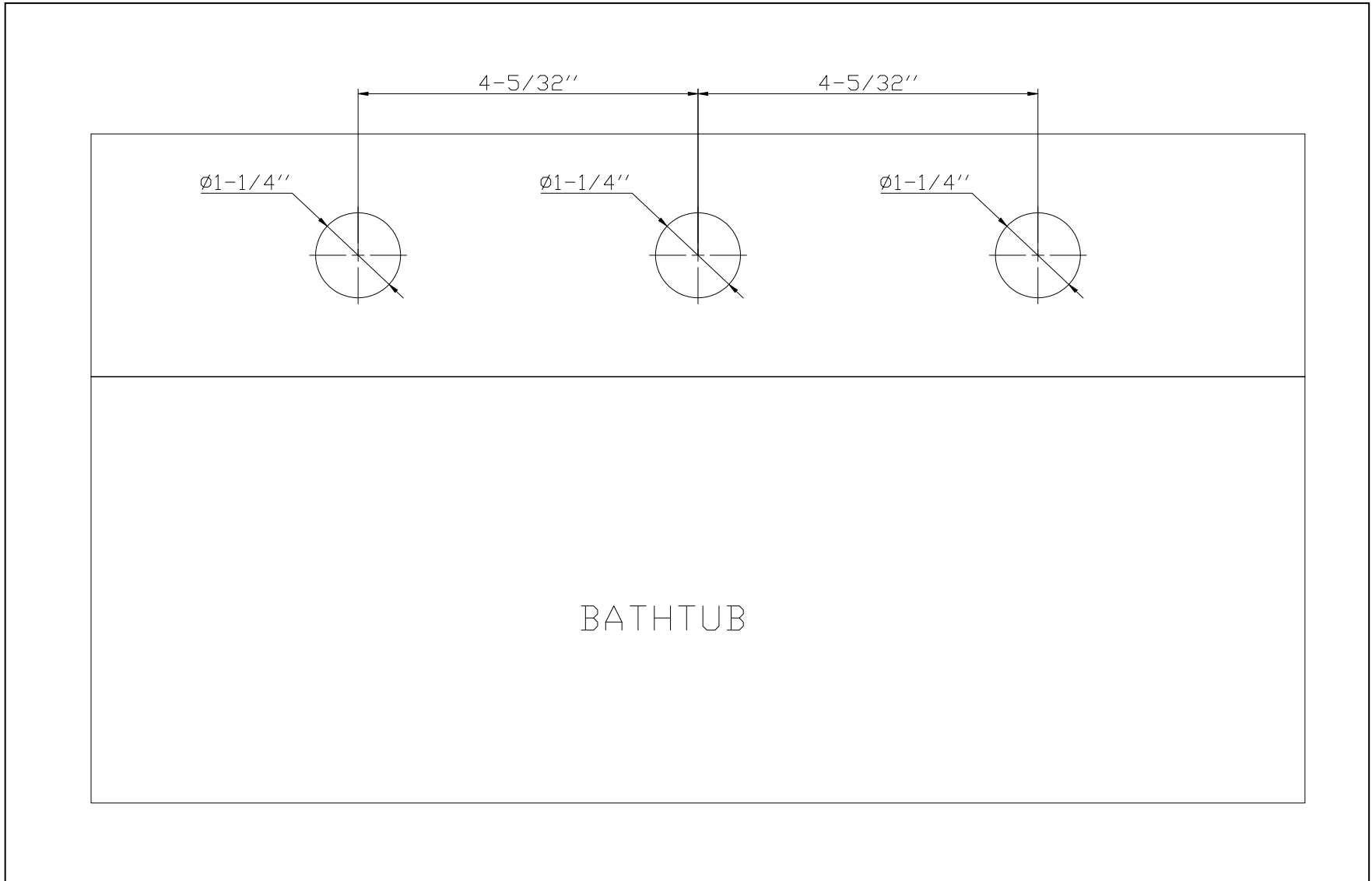

## **5. INSTALLATION**

**5.1** Before connecting the faucet, turn on your shut-off valve to clean the hot and cold water supply pipes. Let the water flush out any dirt and debris for 3-5 minutes. Once done, turn off the water supply again.

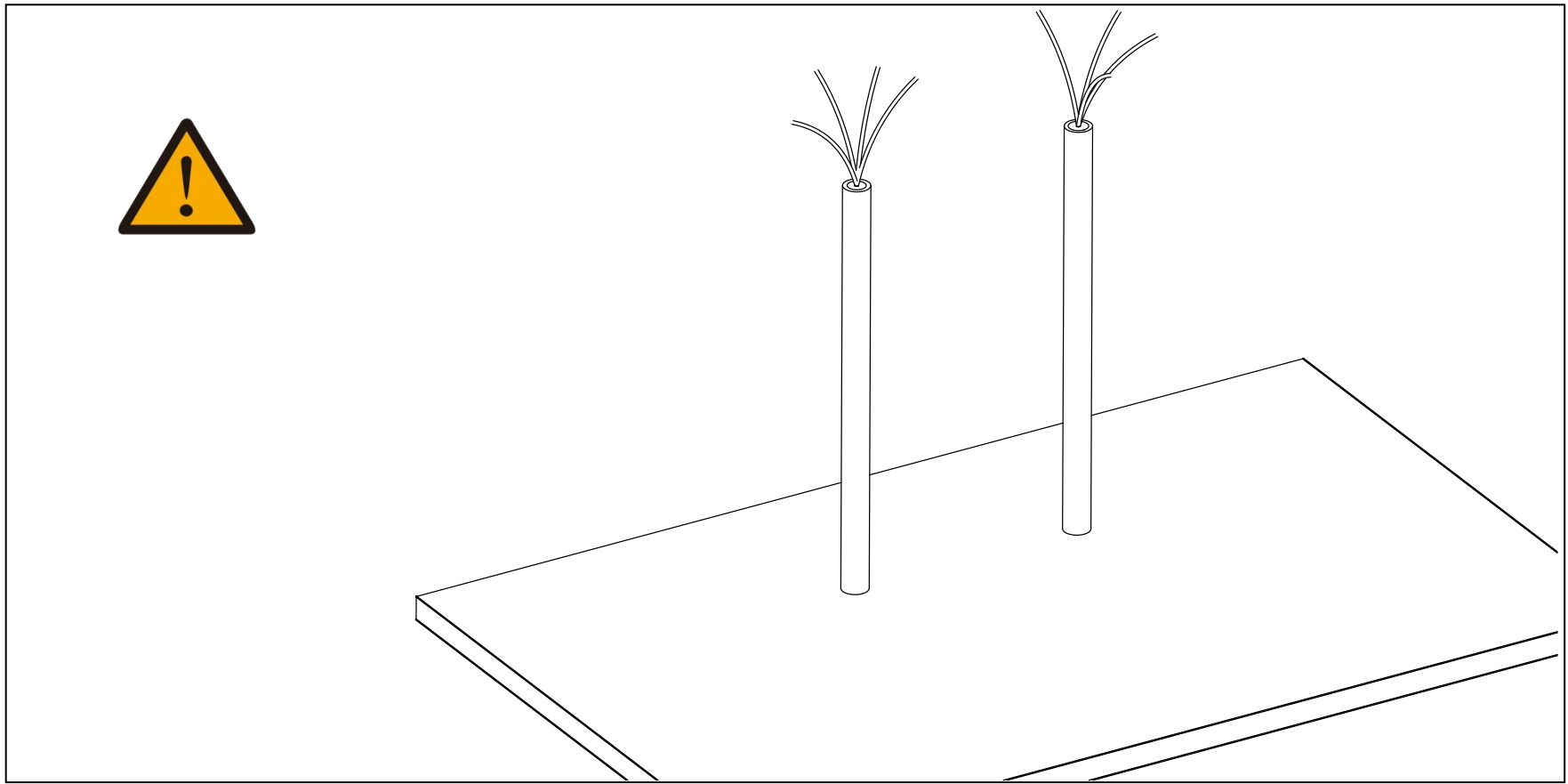

**5.2** Place the spout into the hole on the mounting surface. From underneath, attach a rubber washer to the spout shank and secure it with a locknut using a wrench.

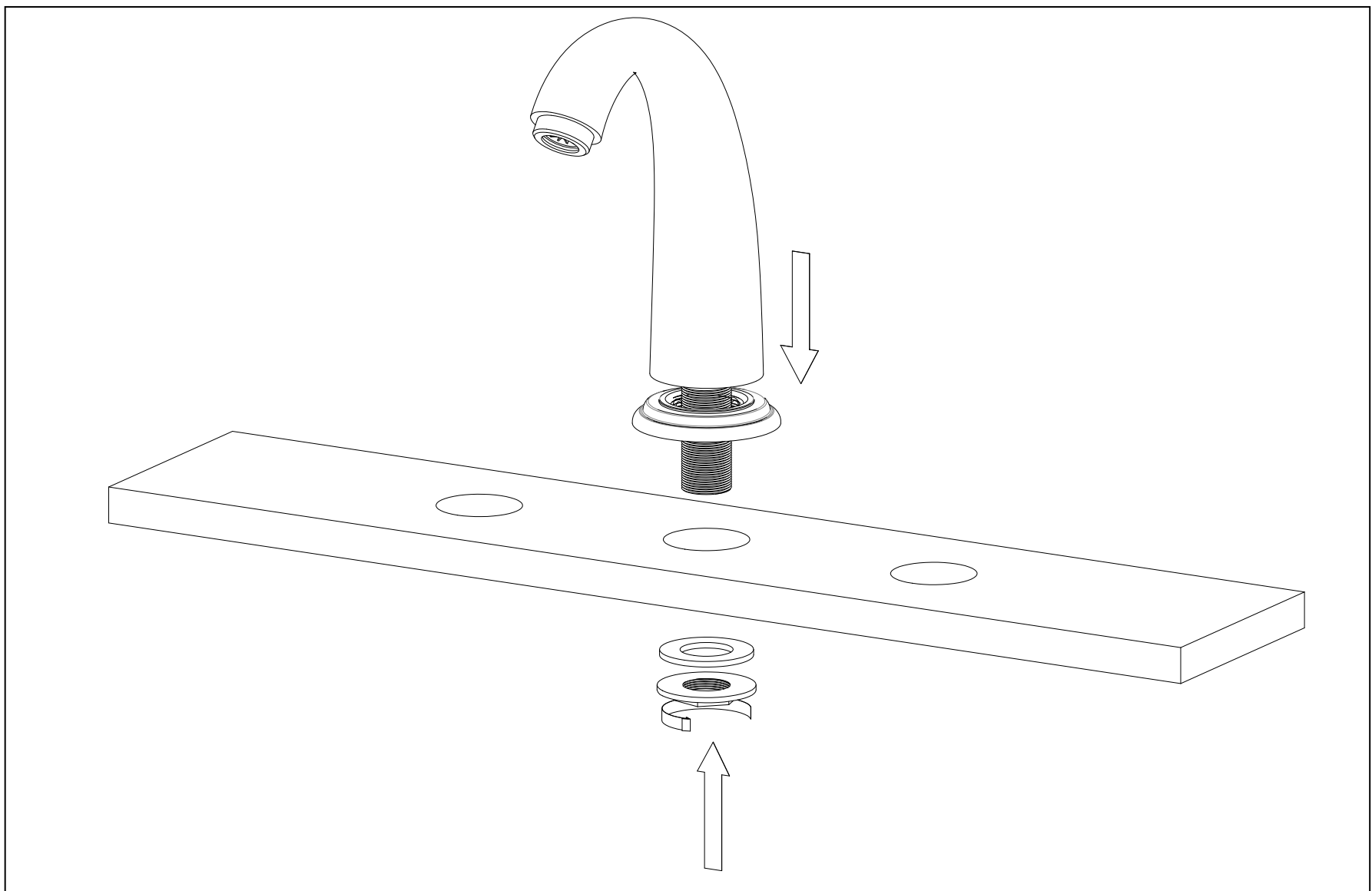

**5.3** Disassemble the hot and cold water valve assembly in preparation for the next installation step. Remove the screw cover from the handle and unscrew the set screw inside counter-clockwise with an Allen wrench. Then, remove the handle from the valve assembly.

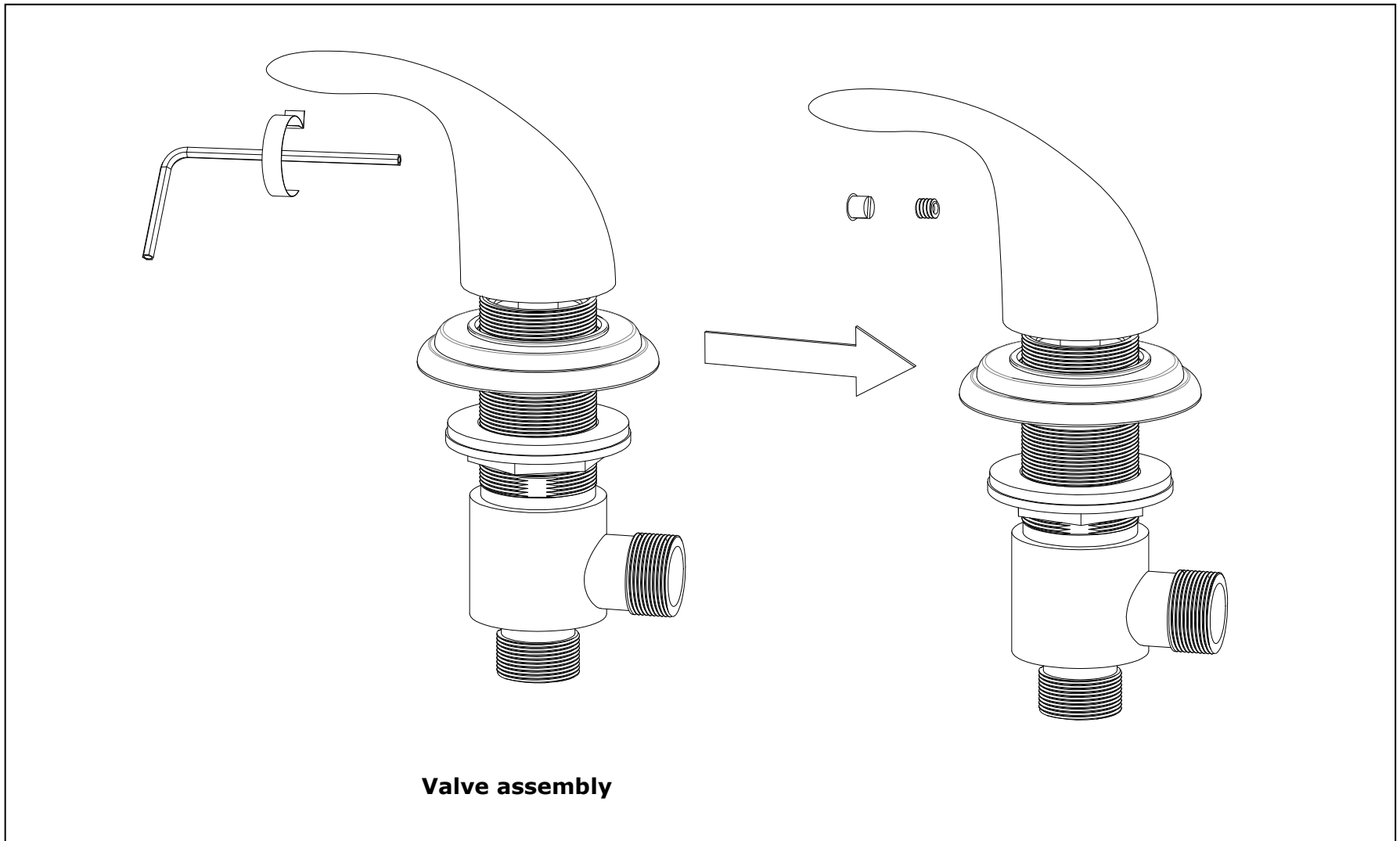

**5.4** Position the valve body on the mounting surface and secure it from underneath with a rubber washer and locknut. Adjust escutcheons to the desired height as needed. Repeat this process for the cold valve assembly on the right.

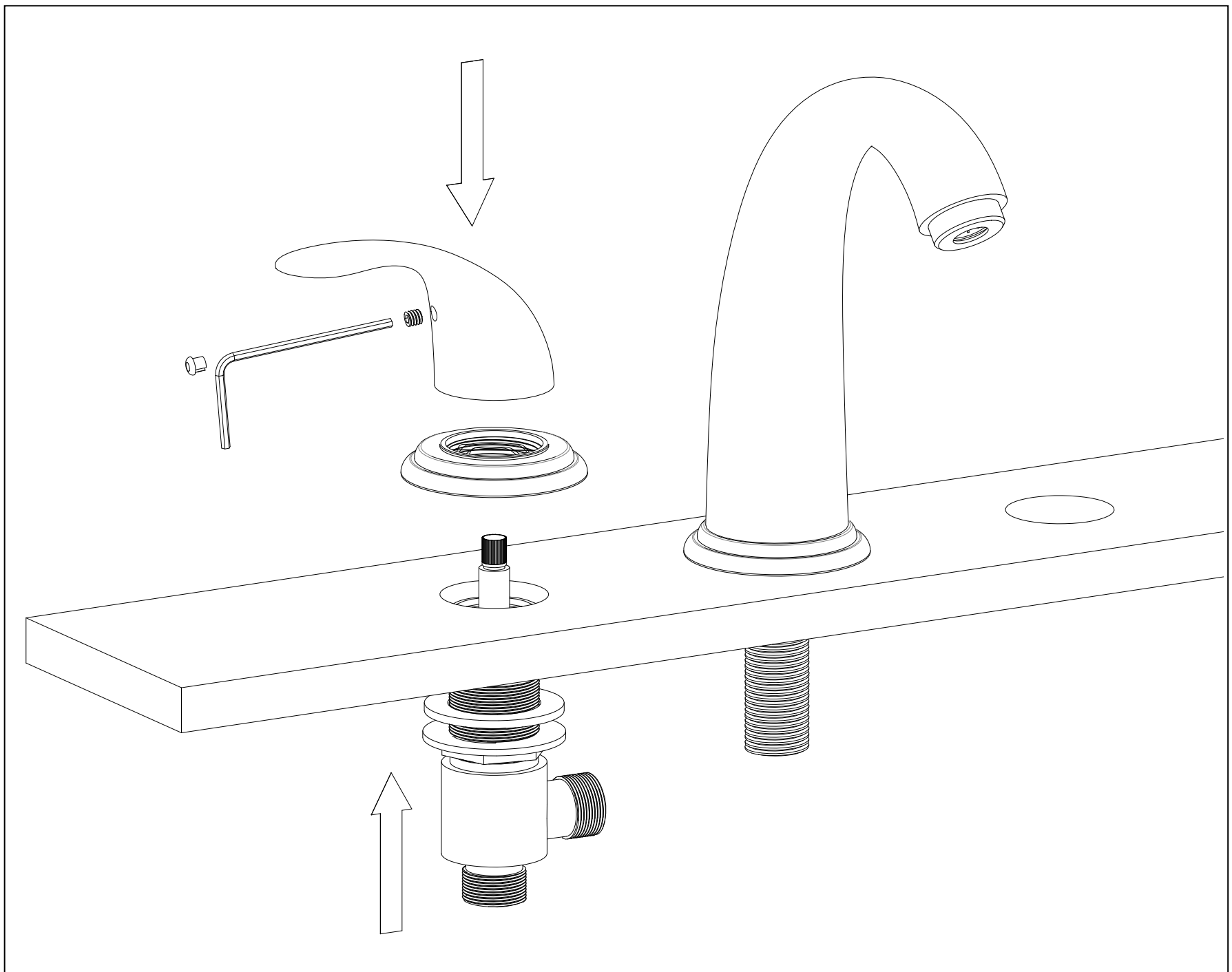

**5.5** Insert the rubber washer into the T-tee to prevent water leakage.

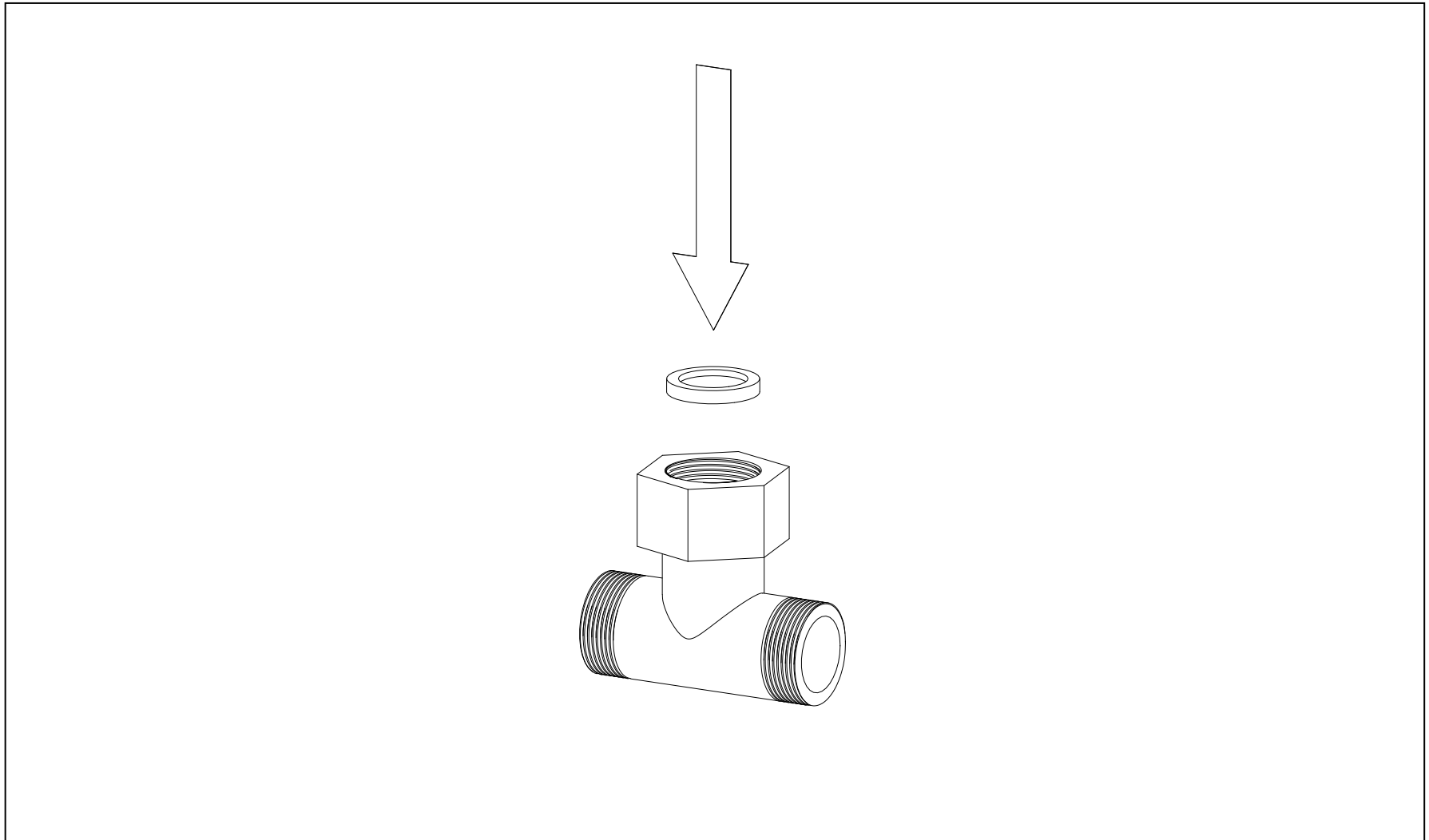

**5.6** Screw the T-tee onto the spout shank.

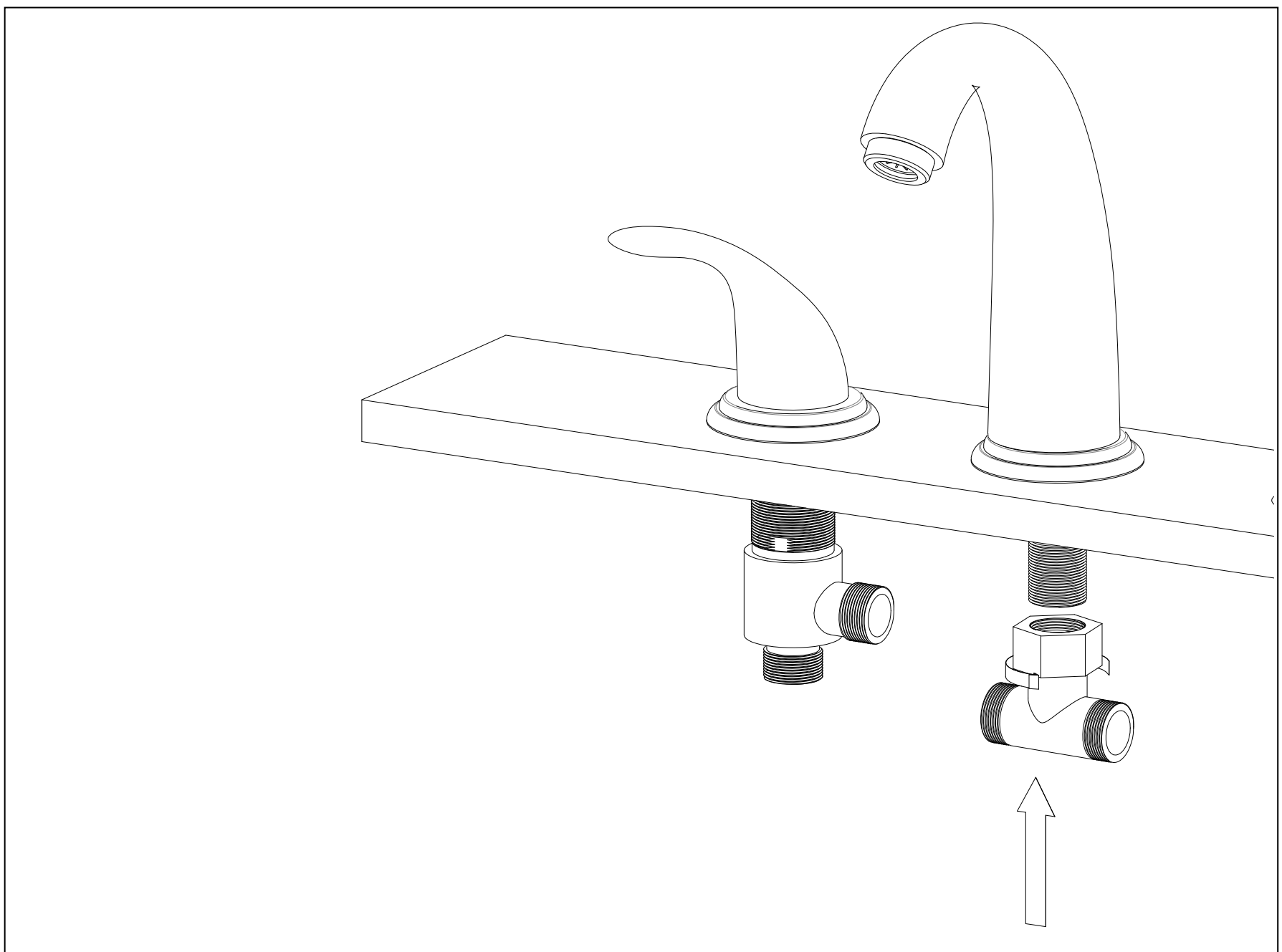

**5.7** Connect the cold and hot water valve bodies to the T-tee using flexible hoses.

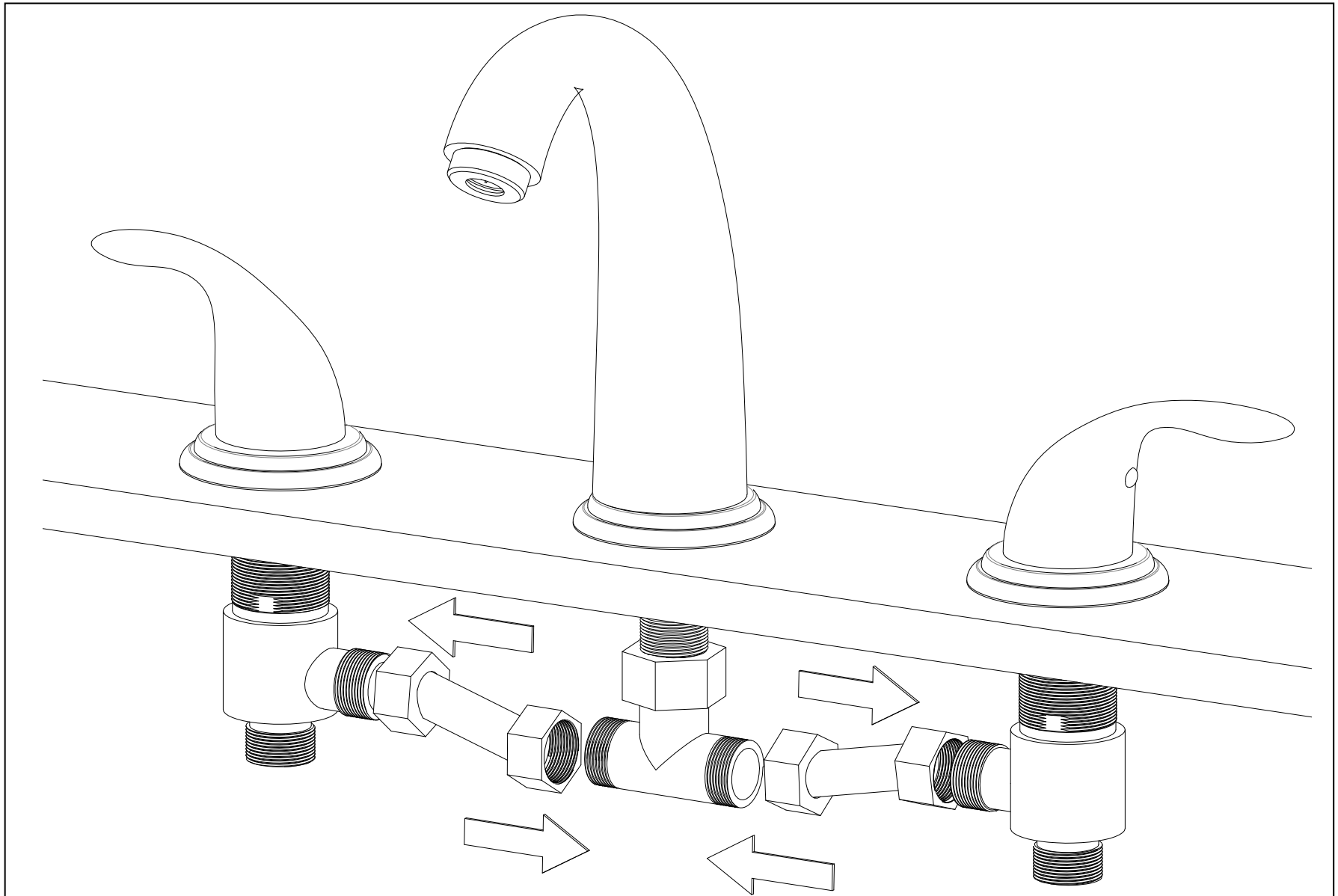

**5.8** Separately connect the inlet connectors of the hot and cold water valve bodies to the stop valve using flexible hoses. The water inlet connections for both valve bodies are G1/2" [1/2 BSPP]. Customers in the US and Canada may need an NPT to BSPP adapter for the connection. If you are unable to find the correct hose for connecting the faucet to your stop valve, please contact Sumerain for assistance.

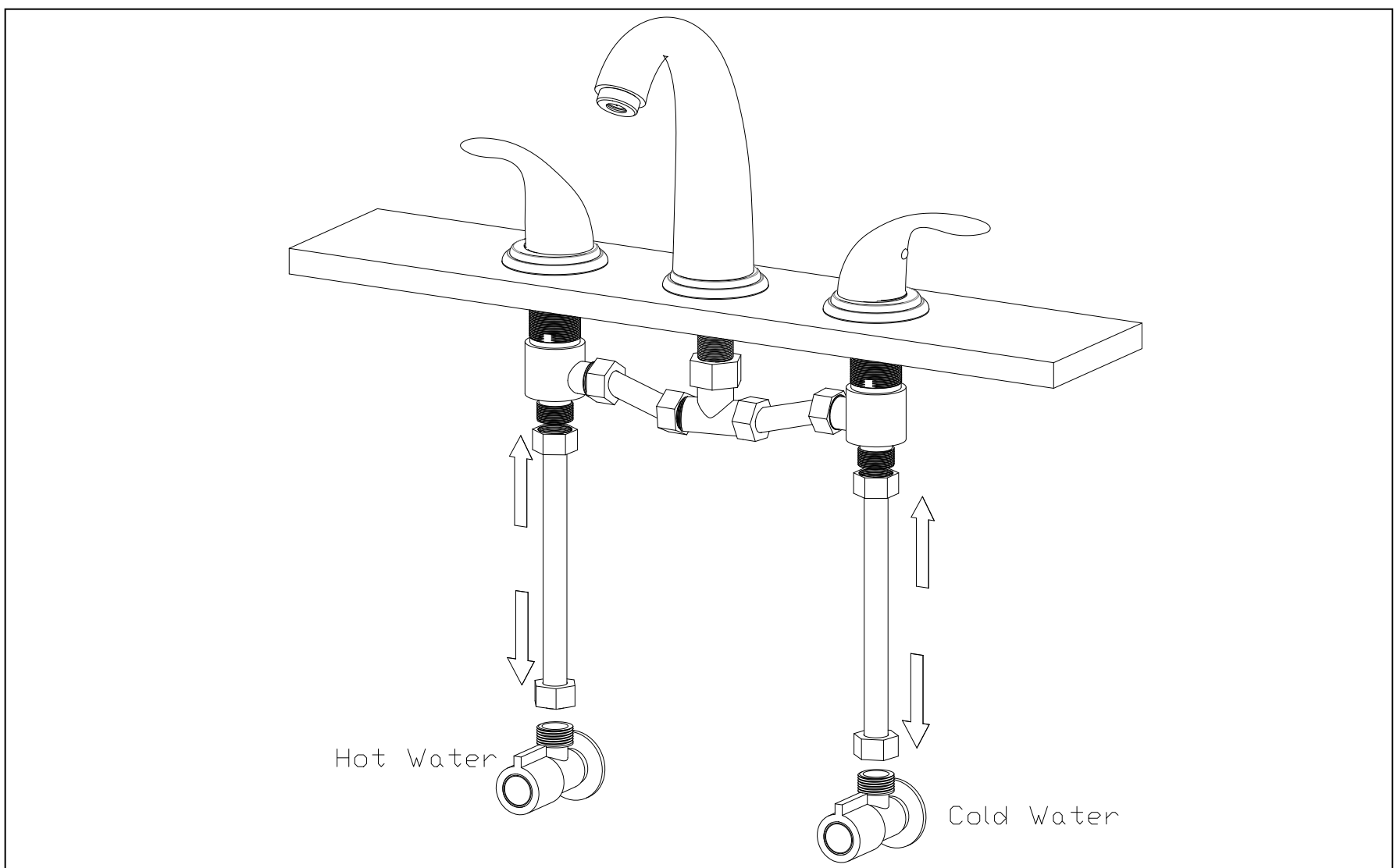

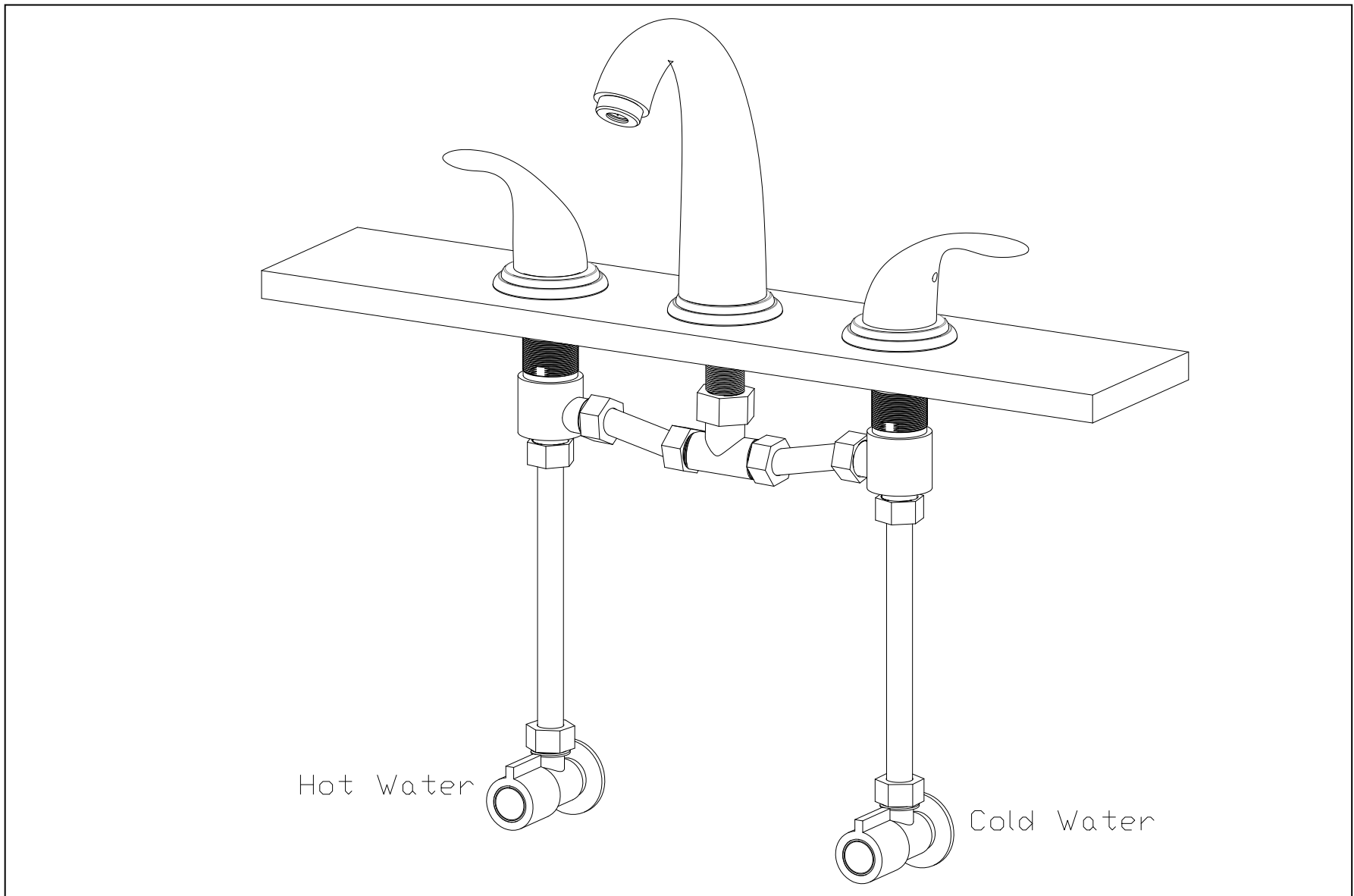

## **6. INSPECTION**

Turn on the hot and cold water supply and check all connections to ensure there are no leaks anywhere.

## **INSTALLATION COMPLETED**

## CLEANING RECOMMENDATION FOR SUMERAIN PRODUCTS

Modern lavatory faucets, kitchen faucets, and showers are built using a wide variety of materials to cater to the market's demands for design and functionality. To avoid damage and potential returns, adhering to specific cleaning guidelines is crucial.

### Cleaning Materials for faucets & showers

When cleaning faucets and showers, it is important to consider the following professional terms:

- Acidic cleaning agents are essential for lime removal.
- Ensure to use only cleaning agents that are specifically designed for this particular application.
- Avoid using cleaning agents containing hydrochloric, formic, phosphoric, or acetic acid, as they can cause significant damage.
- Avoid mixing different cleaning agents, as this can cause harmful chemical reactions.
- Avoid using abrasive cleaning agents or tools, including unsuitable cleaning powders, sponge pads, or microfiber cloths that could damage the surface.

### Cleaning instructions for faucets & showers

Please follow the cleaning material manufacturer's instructions. In addition, pay attention to the following points:

- Clean faucets and showers regularly as needed to maintain their optimal function and appearance.
- Apply the recommended amount of cleaning product for the specified duration. Be sure not to leave the cleaner on the faucets longer than necessary to avoid potential damage.
- Regular cleaning can help prevent calcification. If you notice scale deposits on the faucet surface or spout, use a commercial descaler such as Lime-Away® or CLR®.
- In case of rust formation due to hard water conditions, gently abrade the affected area with aluminum foil soaked in water until the surface is smooth. Subsequently, apply a modest amount of chrome polish or a suitable product like automotive wax (for instance, Meguiar's®, Turtle Wax®) to buff the surface..
- Solid stainless steel faucets and spouts, especially waterfall spouts, typically lack a protective coating. Although stainless steel is naturally resistant to tarnishing, it can oxidize over time and react to its environment. Therefore, it's crucial to keep stainless fixtures clean and dry. Use a cleaner specifically designed for stainless steel, such as Weiman® or CLR®.
- When using a spray cleaner, it is recommended that you first apply it to a soft cloth or sponge rather than spraying it directly onto the faucet. This method helps prevent water droplets from entering the faucet opening and causing potential damage.
- After cleaning, thoroughly rinse with clean water to remove any residue from the cleaner.

### Important

Residues from liquid soap, shampoo, and shower gel can also contribute to damage. Therefore, it's crucial to thoroughly rinse these substances off with clean water after use.



**Note:** if the surface is already damaged, the application of cleaning materials might exacerbate the damage.

**Components with damaged surfaces need to be replaced to avoid potential injuries.**

**Note that any damage resulting from improper treatment is not covered by the warranty.**

**SUMERAIN**®

### SUMERAIN INTERNATIONAL GROUP INC

**Address:** 1226 NORTH KING ST NUM 522  
WILMINGTON, DE 19801  
United States

**Tel:** +1(866)203-0866

**Web:** <http://www.sumerain.com>

**E-mail:** [supports@sumerain.us](mailto:supports@sumerain.us)

### HONGKONG SUMERAIN SANITARY INDUSTRY CO., LIMITED

**Address:** FLAT/RM 3B 3/F BANK TOWER  
NOS.351&353 KING'S ROAD  
NORTH POINT  
HK

**Tel:** +86-750-2731579

**E-mail:** [supports@sumerain.com](mailto:supports@sumerain.com)

### SUMERAIN EUROPE SUPPORT

**Address:** Flottwellstr. 15  
10785 Berlin,  
Deutschland

**Tel:** +49 (0)30/23975898

**E-mail:** [de@sumerain.com](mailto:de@sumerain.com)