

**Thank You
For
Choosing Us**



Tank

INSTRUCTIONS



Naga Bahna

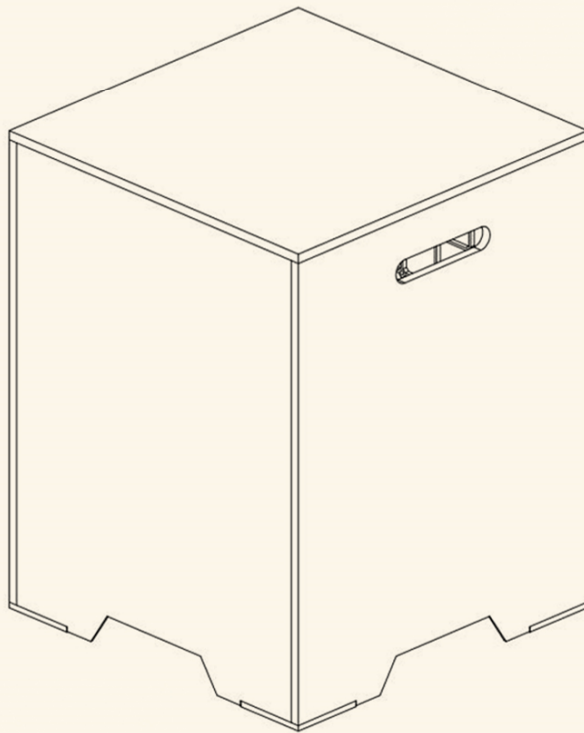

SKU:EURFP010017

NAGA BAHNA Warranty Card

Thank you for choosing NAGA BAHNA products!

We offer a warranty to ensure your product works as expected.
Please read the details below to understand your warranty coverage.

1. Warranty Coverage

Period:

12 months from the date of purchase.

What's Covered:

Defects in materials or manufacturing.

What's Not Covered:

Damage from improper use or lack of care.

Damage caused by accidents, natural disasters, or unauthorized repairs.

Normal wear and tear or parts like batteries or filters.

2. How to Claim Warranty

Contact Us:

If your product has an issue, contact NAGA BAHNA Customer Service
with your proof of purchase and the product's serial number.

Repair or Replacement:

We'll inspect the product and, if covered, repair or replace it for free.

Repair Time:

Typically 7-14 business days.

3. Customer Service

Phone: +17197595710

Email: customerservice@nagabahna.com.cn

Website: www.nagabahna.com.cn

4. Important Notes





Keep this card safe as it proves your warranty.

Warranty only applies to products bought from NAGA BAHNA or authorized sellers.

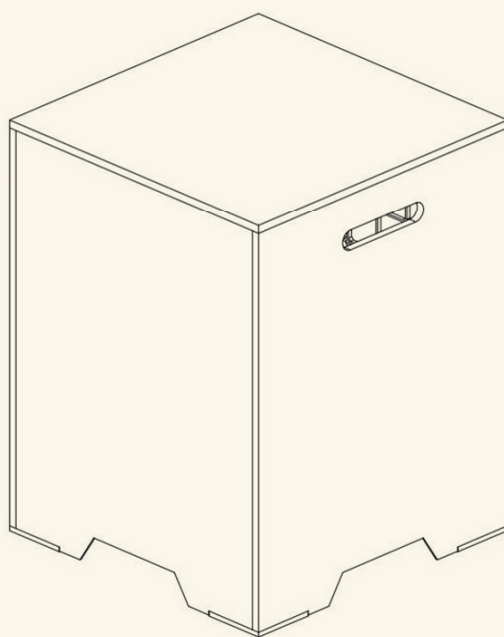
NAGA BAHNA
Committed to quality and your satisfaction.

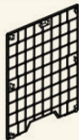
Accessory

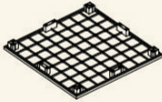

Item no.	Reference Image	Description	Qty
A		Side Panel A	2
B		Side Panel B	2
C		Top Panel C	1
D		Square Snap-fit	4
E		Triangle Snap-fit with adjust foot pre-assembled	4

STEP 1

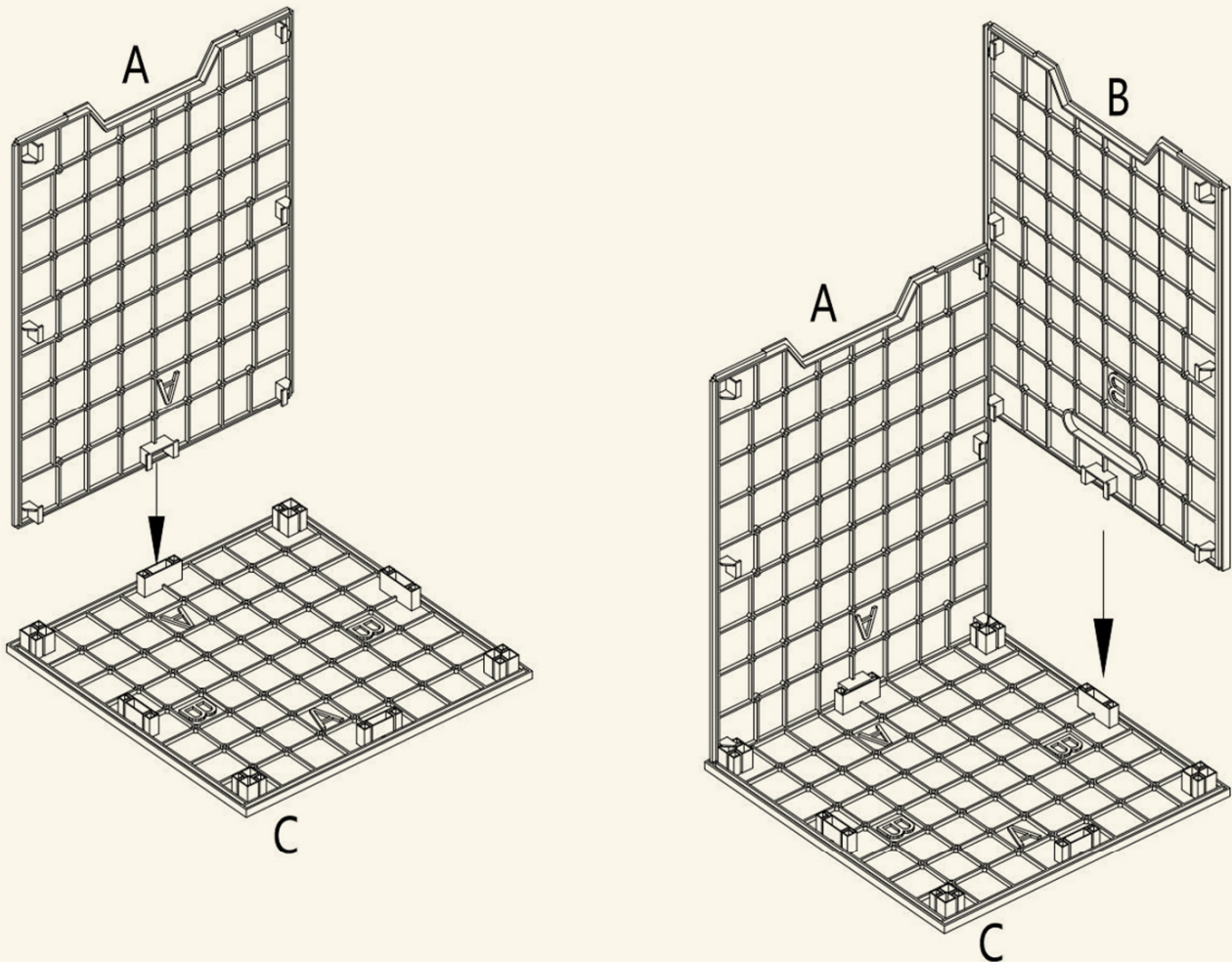

1. Insert Side Panel (A) into the Top Panel (C).
2. Next, insert Side Panel (B) into the Top Panel (C).
3. Ensure the letter markings on the four sides of the Top Panel (C) are aligned correctly: Side Panel (A) should be aligned with the side marked "A," and Side Panel (B) with the side marked "B."

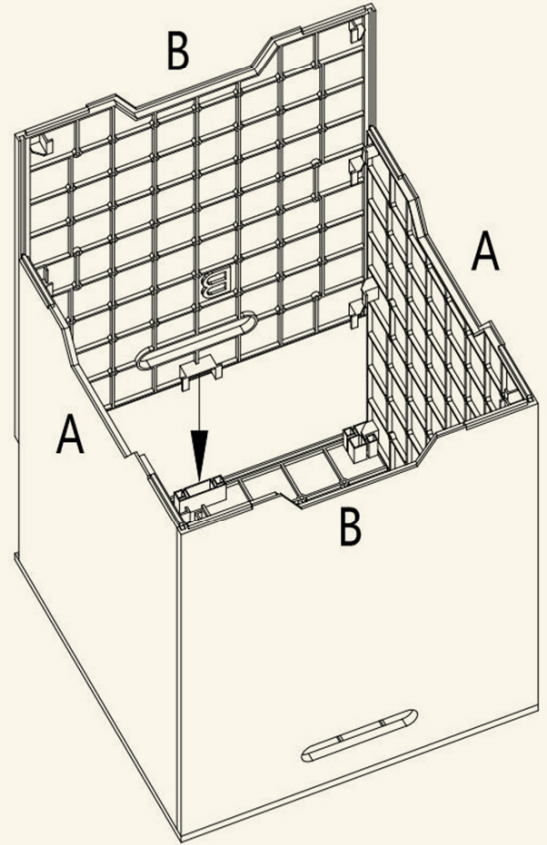
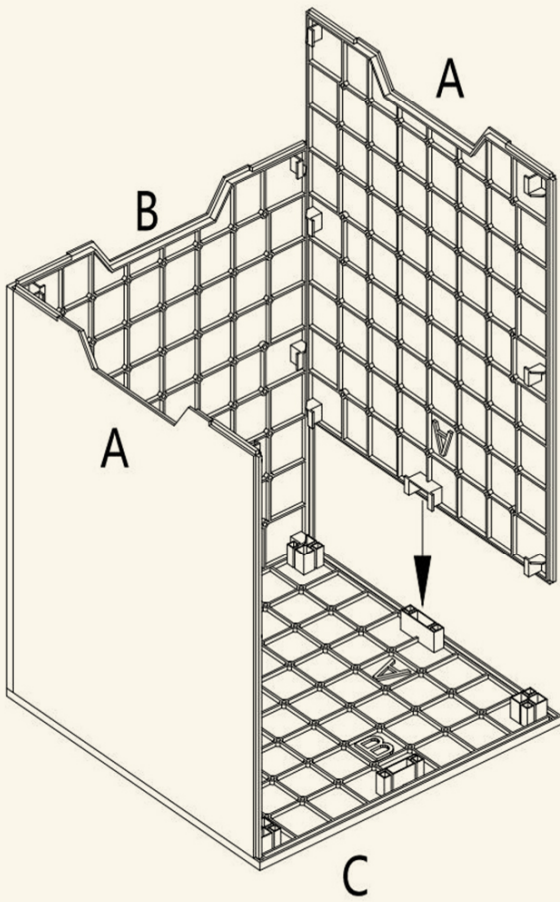

Repeat for the steps above.

STEP 2

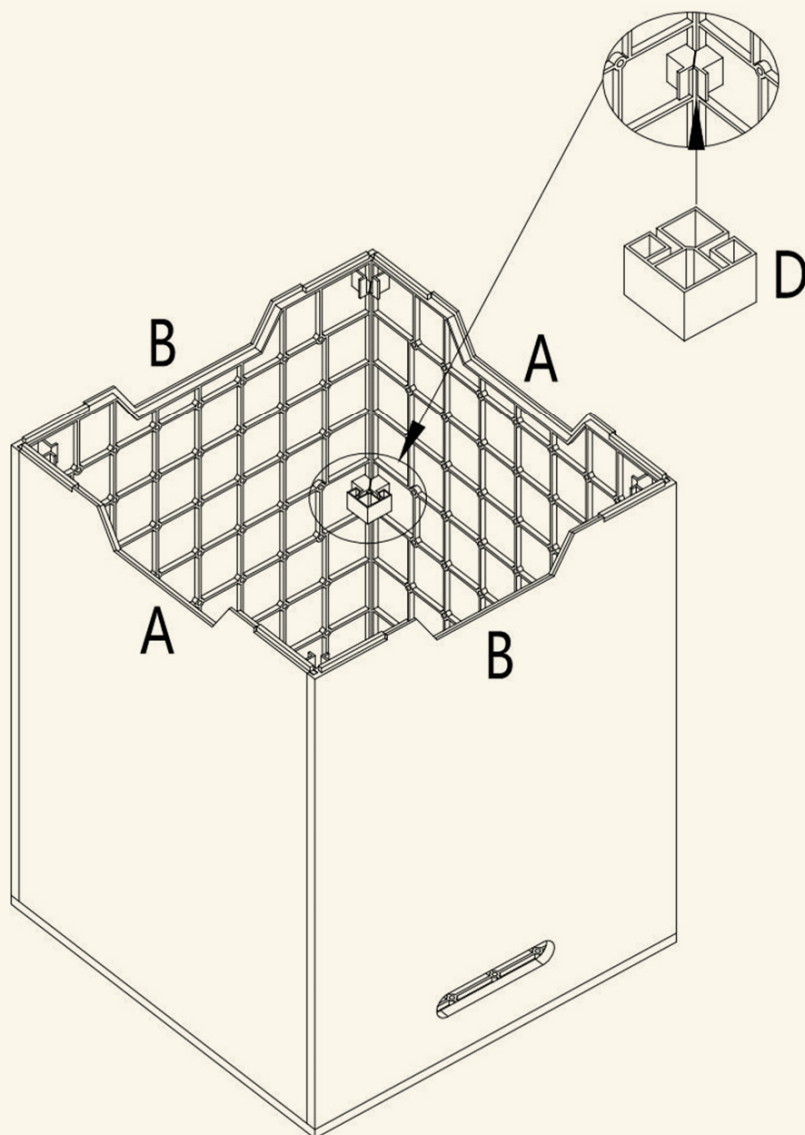

Secure the square snap-fit (D) between side panel (A) and side panel (B).

STEP 3

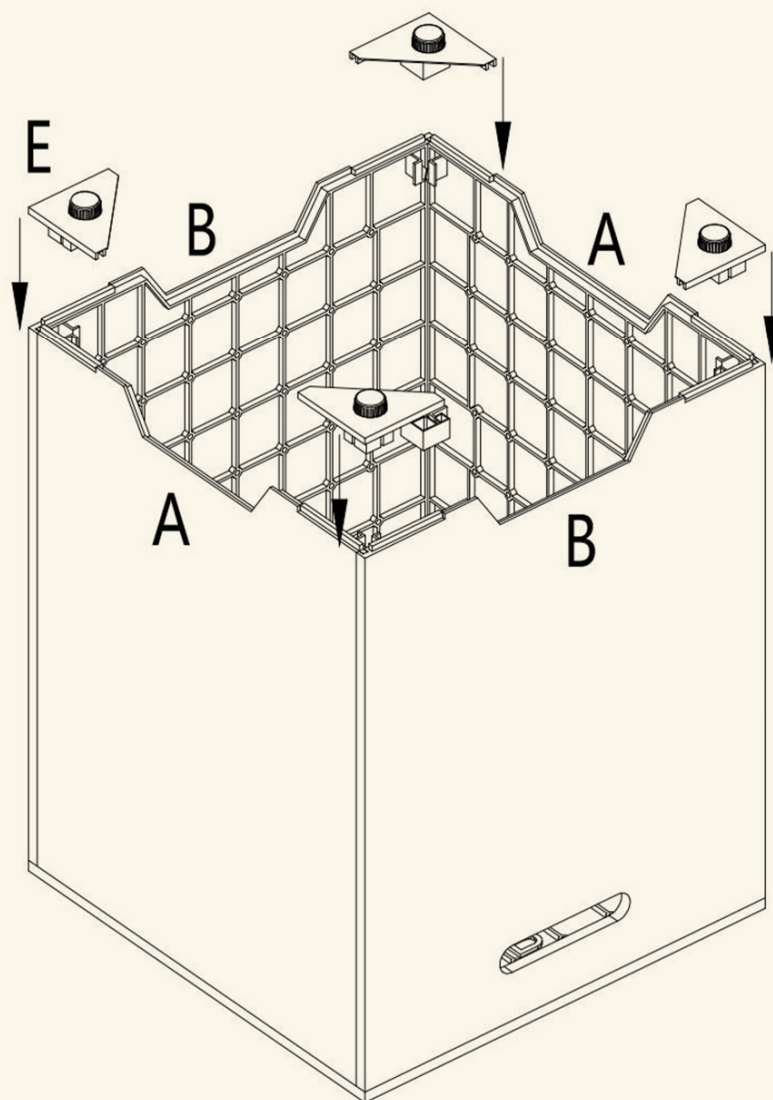

Secure the triangle snap-fit (E) into the base of side panel (A) and panel (B). Then, flip it over and you can start using it.

Warranty Information

We appreciate your feedback and will do our best to guarantee your satisfaction. If you have any questions, please contact us at **customerservice@nagabahna.com.cn**. Our professional after-sales service team is always here for you.

This is the only express warranty for this product and is in lieu of any other warranty or condition. This product is warranted to be free from defects in material and workmanship for a period of one (1) year from the date of original purchase. During this period, your exclusive remedy is repair or replacement of this product or any component found to be defective, at our option; however, you are responsible for all costs associated with returning the product to us and our returning a product or component under this warranty to you. If the product or component is no longer available, we will replace with a similar one of equal or greater value.

This warranty does not include Waterproof cover, wear from normal use, use not in conformity with the printed directions, or damage to the product resulting from accident, alteration, abuse, or misuse. This warranty extends only to the original consumer purchaser or gift recipient. Keep the original sales receipt, as proof of purchase is required to make a warranty claim.

This warranty is void if the product is used for other than single-family household use or receive external force for artificial damage. We exclude all claims for special, incidental, and consequential damages caused by breach of express or implied warranty. All liability is limited to the amount of the purchase price. Every implied warranty, including any statutory warranty or condition of merchantability or fitness for a particular purpose, is disclaimed except to the extent prohibited by law, in which case such warranty or condition is limited to the duration of this written warranty. This warranty gives you specific legal rights. You may have other legal rights that vary depending on where you live. Some states or provinces do not allow limitations on implied warranties or special, incidental, or consequential damages, so the foregoing limitations may not apply to you.