

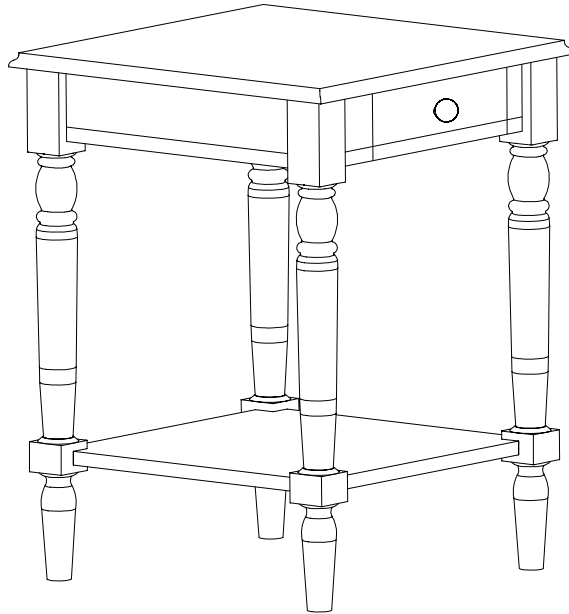







End Table

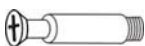
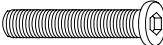

HARDWARE LIST

CODE	NAME	FIGURE	Q'TY
A	CAM LOCKS (Ø15x9mm)		4PCS
B	CAM BOLTS (Ø6.5x35mm)		4PCS
C	RAIL SCREW (Φ1/4"*51mm)		8PCS
D	SPRING WASHER (Φ1/4")		8PCS
E	FLAT WASHER (Φ1/4"*16mm)		8PCS
F	ALLEN WRENCH		1PC
G	MACHINE SCREW (22mm)		1PC
H	HANDLE		1PC

PARTS LIST

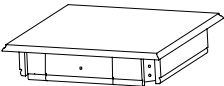
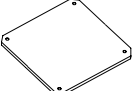
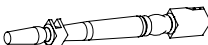
CODE	NAME	FIGURE	Q'TY
①	TOP PANEL		1PC
②	BOTTOM PANEL		1PC
③	LEG		4PCS

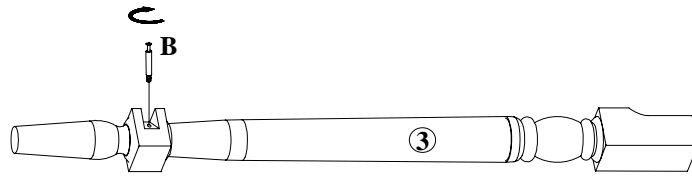

B x 4pcs

STEP 1

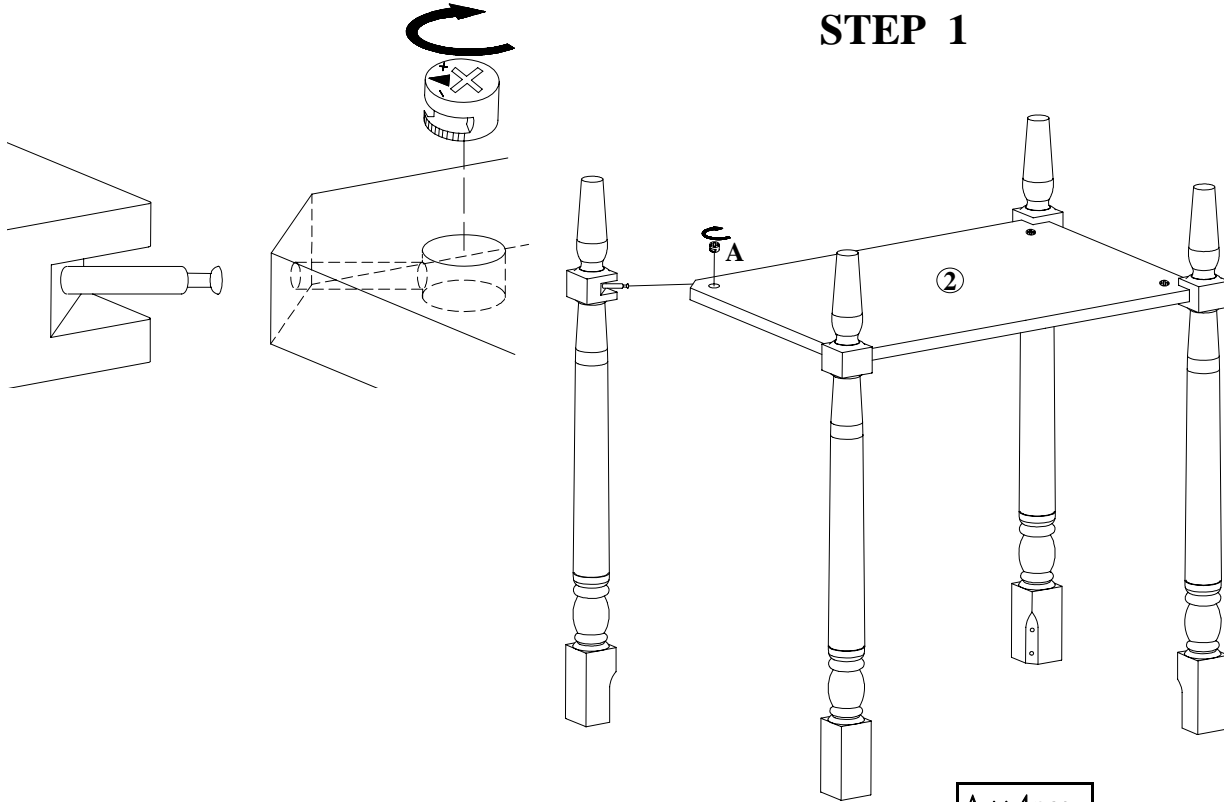

A x 4pcs

STEP 2

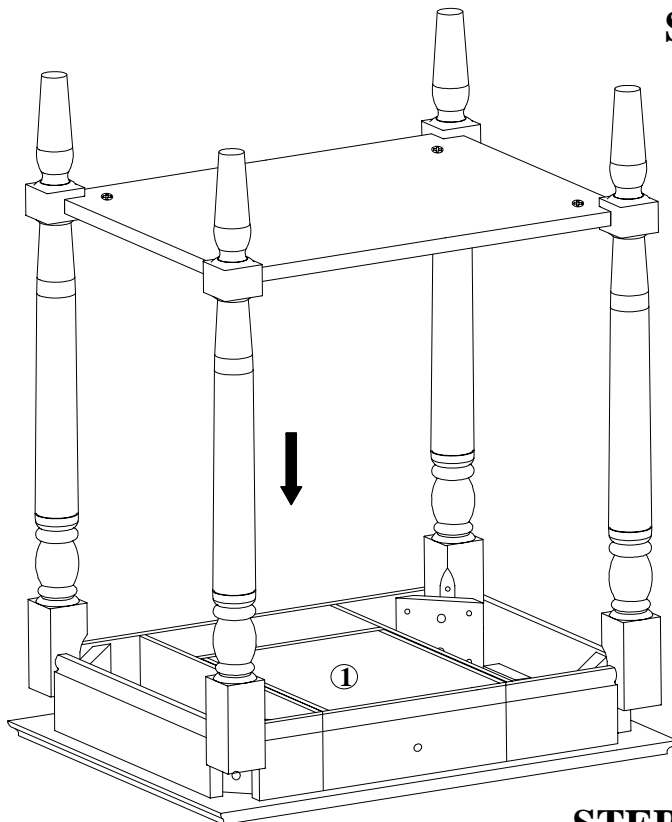

STEP 3

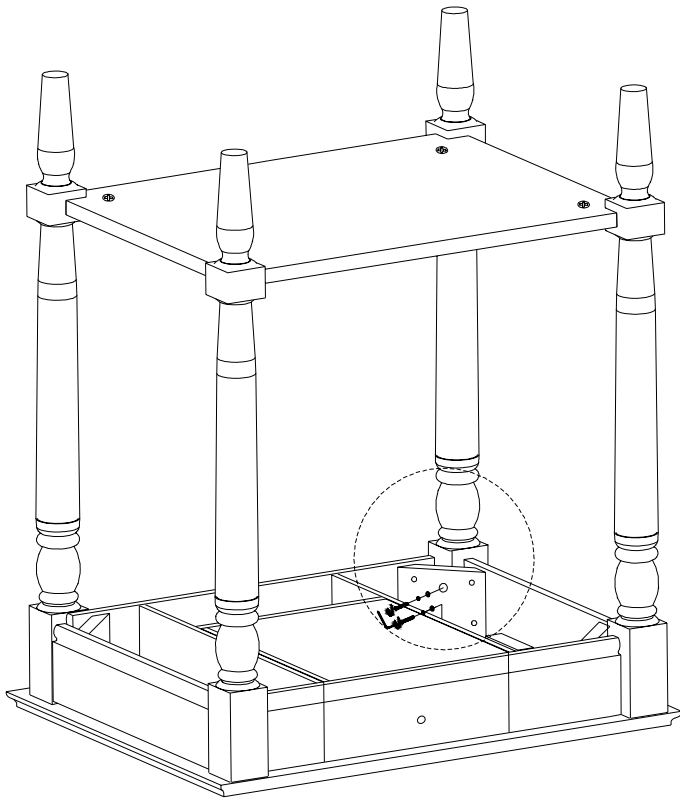

- C x 8pcs
- D x 8pcs
- E x 8pcs
- F x 1pc

STEP 4

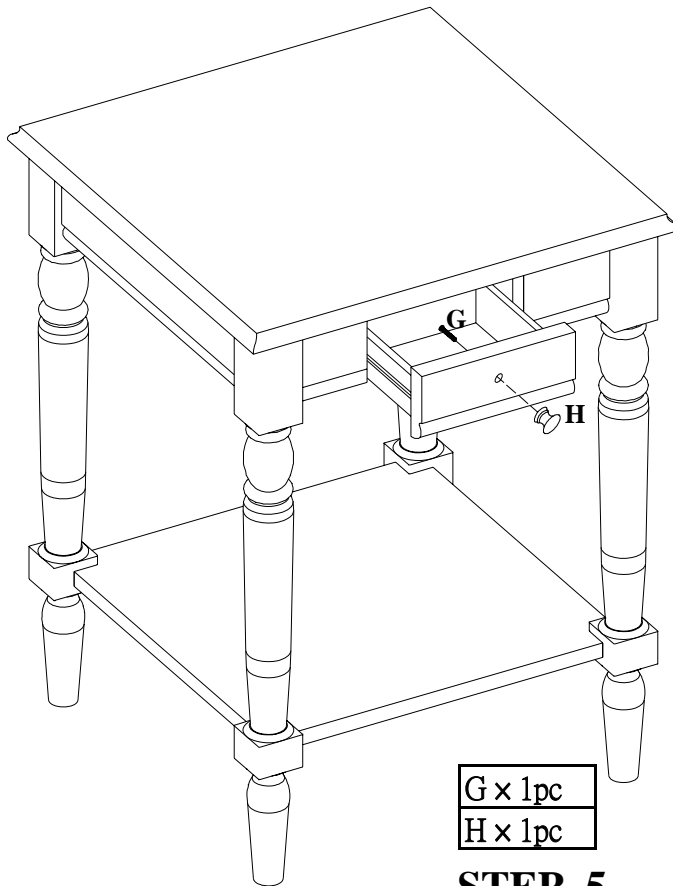

- G x 1pc
- H x 1pc

STEP 5

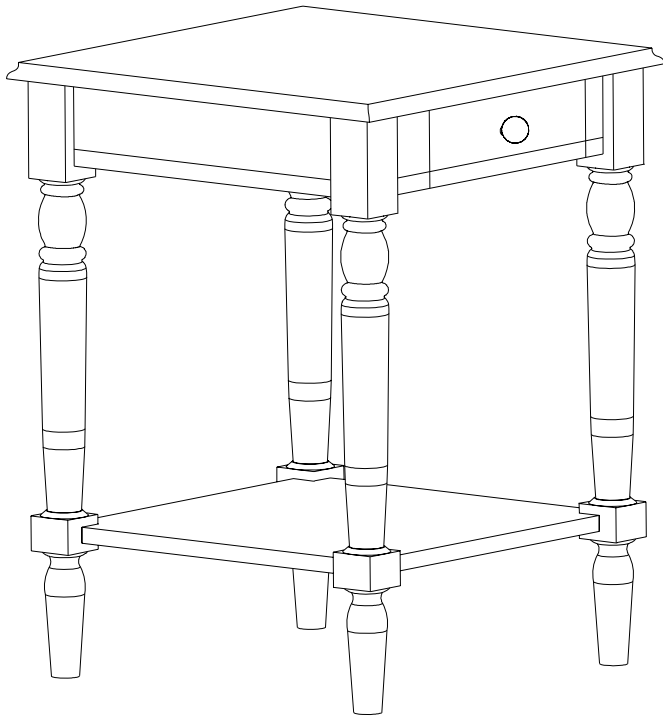

STEP 6