



ASSEMBLY INSTRUCTIONS
COASTER FINE FURNITURE



Fine Furniture for every stage of life

100770
Dining Table

REVISION 0: 01/10/2006
REVISION 1: 03/19/2012
REVISION 2: 11/26/2012
REVISION 3: 09/06/2018
REVISION 4: 07/13/2020

ITEM: 100770



ASSEMBLY INSTRUCTIONS

ASSEMBLY TIPS :

1. Remove hardware from box and sort by size.
2. Please check to see that all hardware and parts are present prior to start of assembly.
3. Please follow attached instructions in the same sequence as numbered to assure fast & easy assembly.



WARNING !

1. Don't attempt to repair or modify parts that are broken or defective. Please contact the store immediately.
2. This product is for home use only and not intended for commercial establishments.

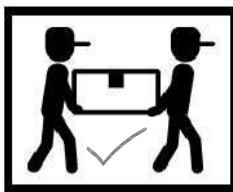

ASSEMBLY TIME

10 MINUTES

PARTS IDENTIFICATION

A	TOP		1PC
B	LEG		4PCS
C	LEAF		1PC
D	APRON		2PCS

HARDWARE IDENTIFICATION

1	WRENCH (12.8MM - RBW)		1PC
2	ALLEN WRENCH (M4 x 63MM - BLK)		1PC
3	HEX NUT (5/16" - RBW)		8PCS
4	LOCK WASHER (5/16" -RBW)		8PCS
5	FLAT WASHER (5/16" -RBW)		8PCS
6	BOLT (M6 x 60MM -BLK)		4PCS

ITEM: **100770**

ASSEMBLY INSTRUCTIONS



STEP 1

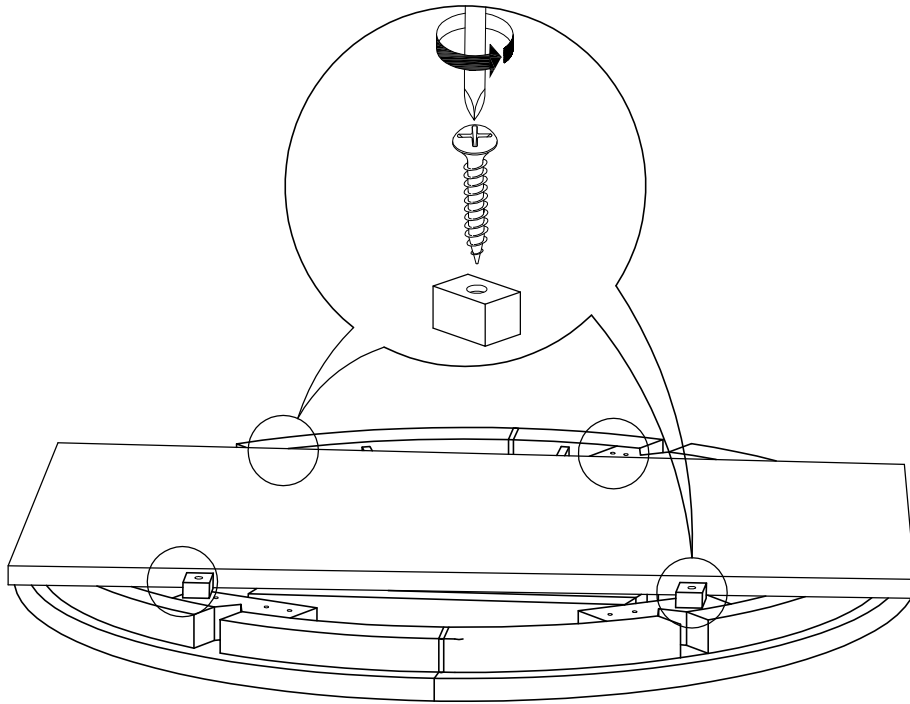

STEP 2

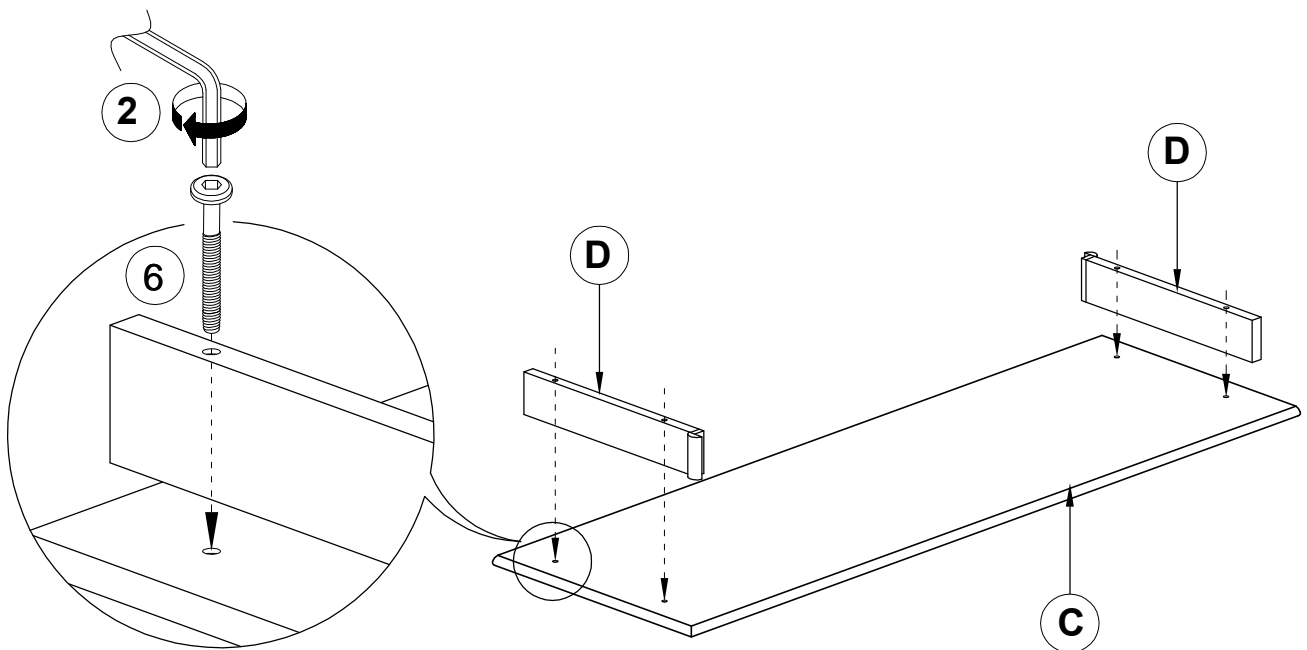

ITEM: **100770**
ASSEMBLY INSTRUCTIONS



STEP 3

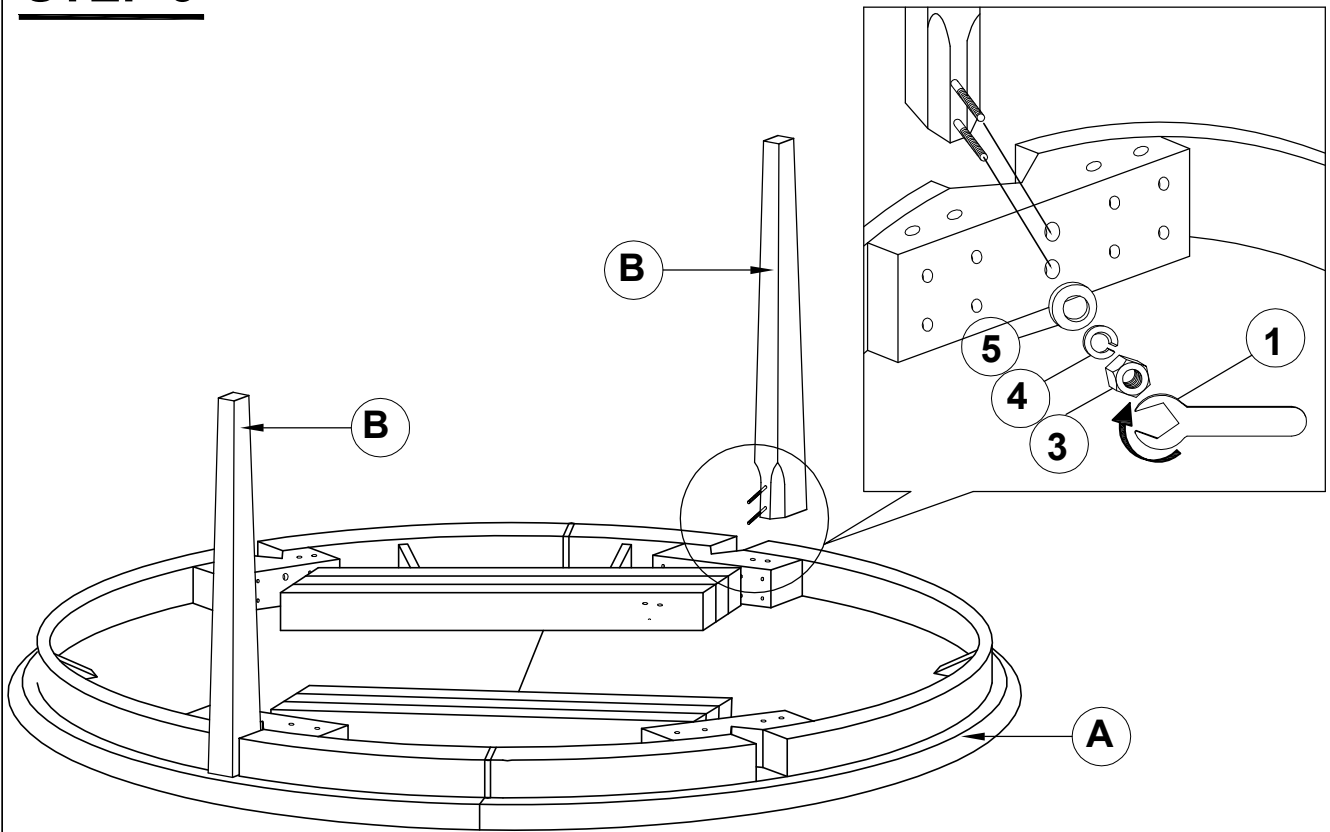

STEP 4

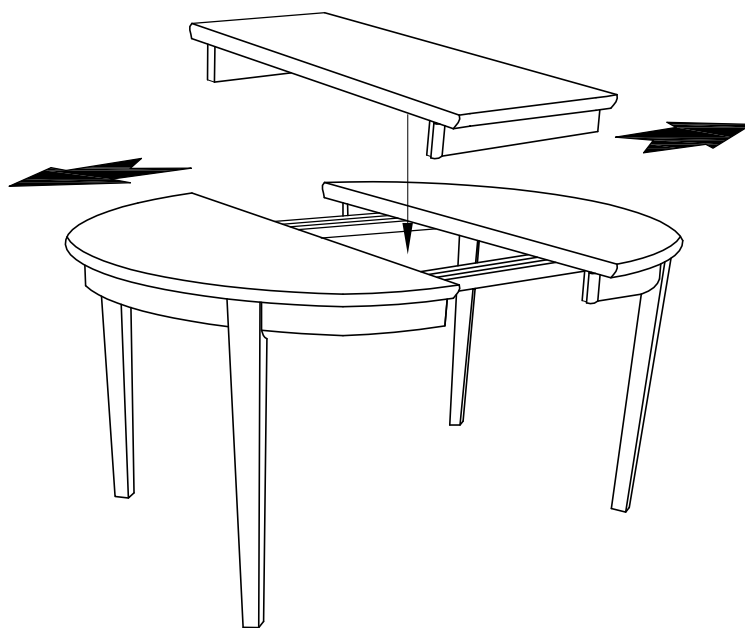

ITEM: **100770**

ASSEMBLY INSTRUCTIONS



STEP 5

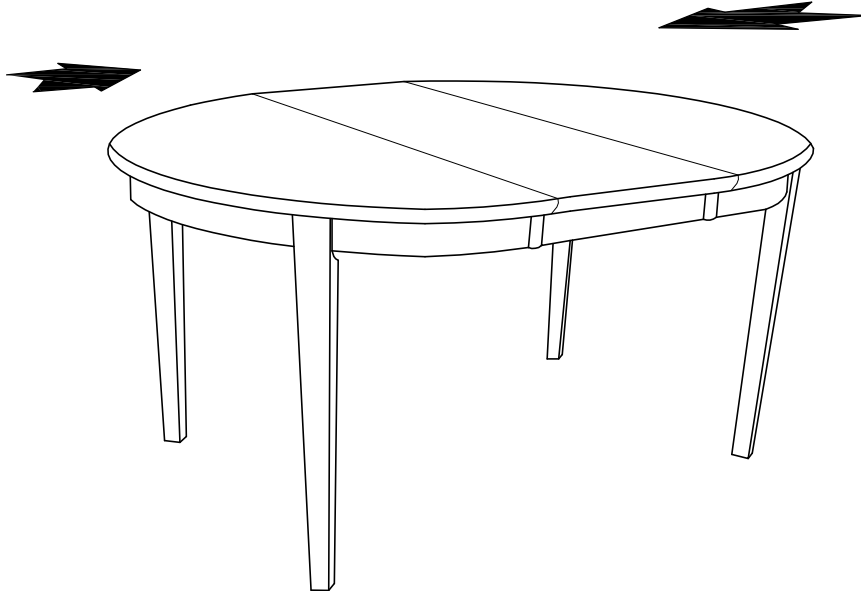

STEP 6
COMPLETE

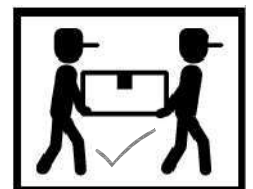

ITEM: **100770**

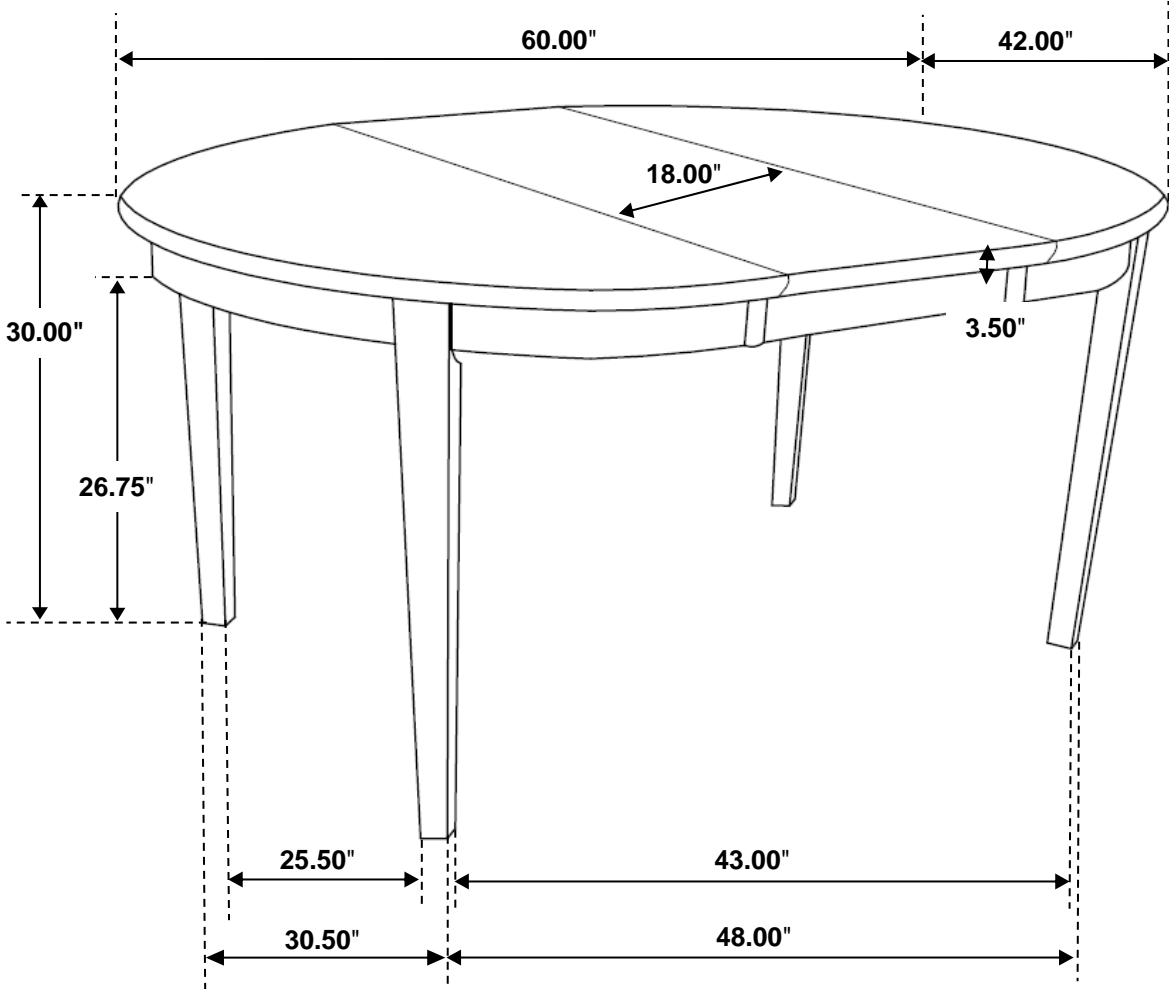

Note: Dimension tolerance $\pm 5\%$



ASSEMBLY INSTRUCTIONS
COASTER FINE FURNITURE



Fine Furniture for every stage of life

100773
Dining Side Chair

REVISION 0: 01/10/2006
REVISION 1: 02/17/2012
REVISION 2: 07/13/2020

PAGE 1 OF 4

COASTERFURNITURE.COM

ITEM: **100773**



ASSEMBLY INSTRUCTIONS

ASSEMBLY TIPS :

1. Remove hardware from box and sort by size.
2. Please check to see that all hardware and parts are present prior to start of assembly.
3. Please follow attached instructions in the same sequence as numbered to assure fast & easy assembly.



WARNING !



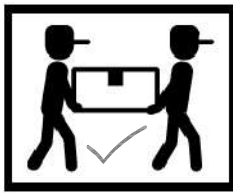

1. Don't attempt to repair or modify parts that are broken or defective. Please contact the store immediately.
2. This product is for home use only and not intended for commercial establishments.





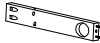

ASSEMBLY TIME

30 MINUTES

PARTS IDENTIFICATION

A	BACK FRAME		1PC
B	FRONT LEG FRAME		1PC
C	SIDE RAIL		2PCS
D	SEAT CUSHION		1PC

HARDWARE IDENTIFICATION

1	ALLEN WRENCH (M4 x 110MM - BLK)		1PC
2	BOLT (M6 x 50MM - RBW)		6PCS
3	LOCK WASHER (1/4" - BLK)		6PCS
4	PAN HEAD SCREW (#8 x 1" -BLK)		4PCS

NOTE :

Phillips head screw driver is required in the assembly process ; However, manufacturer not provide this item. Quantities shown are for one chair.

ITEM: **100773**
ASSEMBLY INSTRUCTIONS



STEP 1

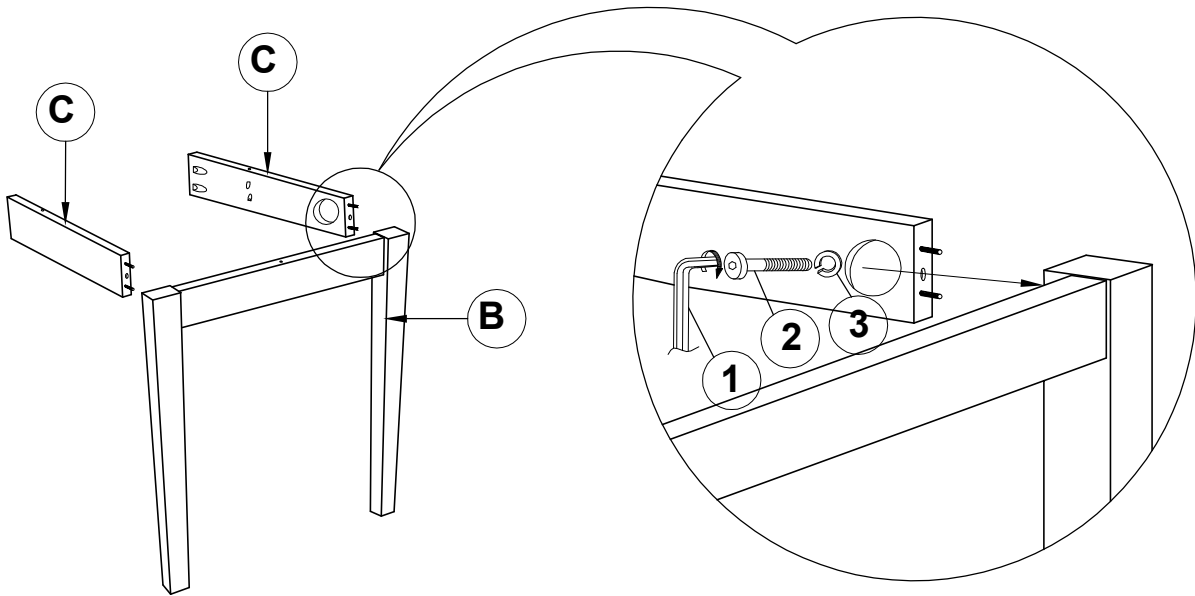

STEP 2

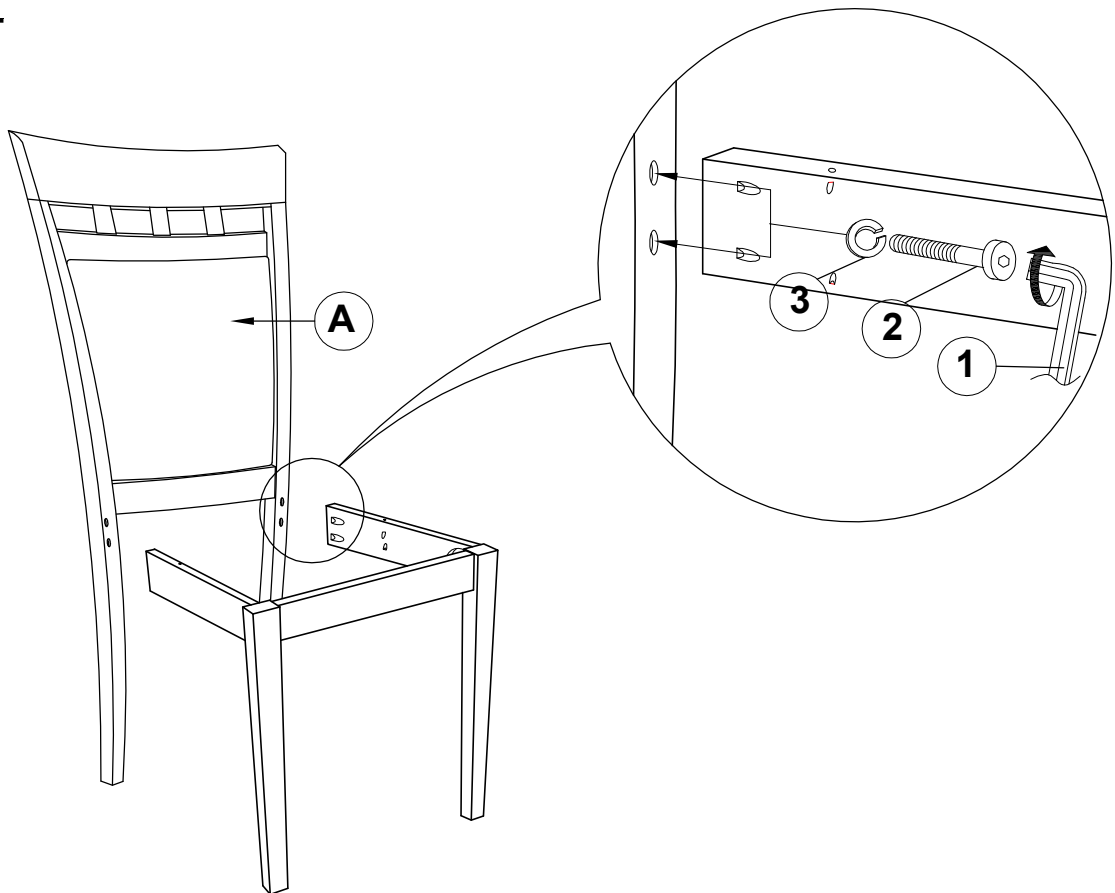

ITEM: **100773**

ASSEMBLY INSTRUCTIONS

STEP 3

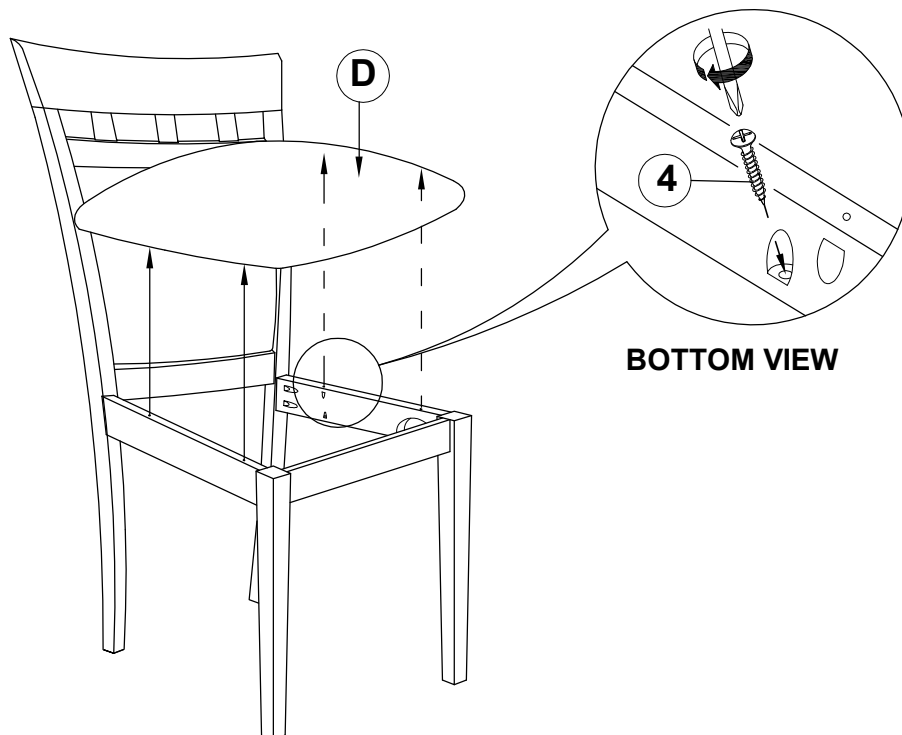

STEP 4
COMPLETE

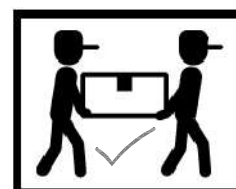
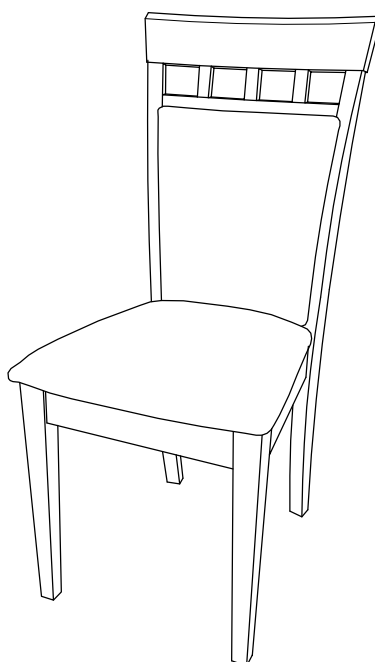

ITEM: 100773

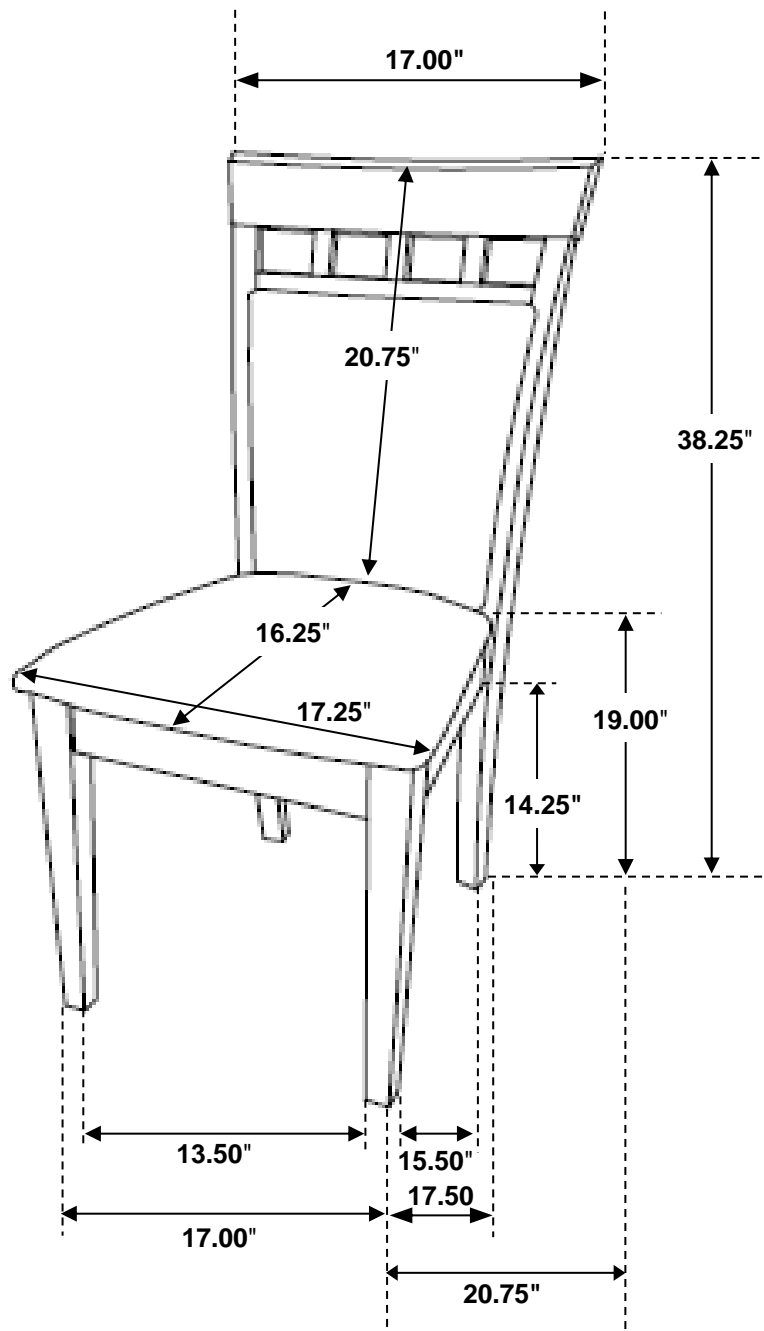

Note: Dimension tolerance $\pm 5\%$