

## Owner Manual

---

### NOTE:

This brochure contains IMPORTANT safety info. Please read and keep for future reference.

---

# MAINTAINANCE AND WARNING

- 1.Keep furniture away from heat sources.
- 2.Do not clean furniture with harsh cleaner or polishes.Do not use detergents,solvents,abrasives,spray packs or leather cleaner. Use non-color mild soa with warm water to clean spills(Mix 1:10 soap to water).
- 3.Do not place furniture under direct sunlight,material will possibly fade over time.
- 4.Do not use on site dry cleaning machine.Children should not climb or jump on the furniture.
- 5.Do not write on furniture that is not protectedby a padded barrier.
- 6.Not for commercial use,only for residential use.



Weight Limitation  
**1050 LBS**

# PARTS LIST

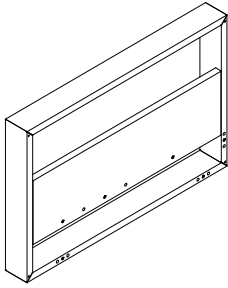
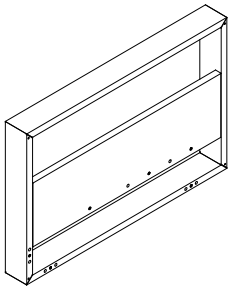
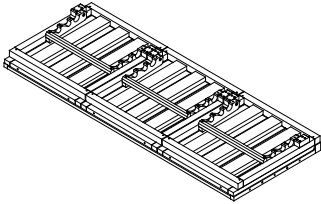
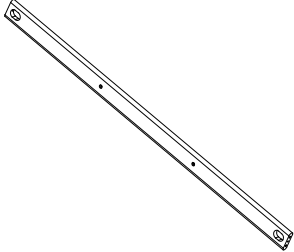
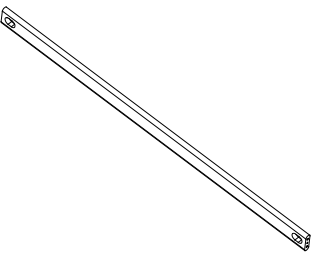
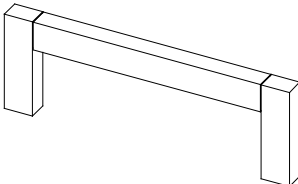
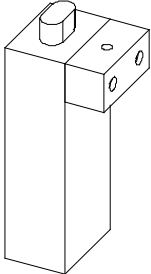
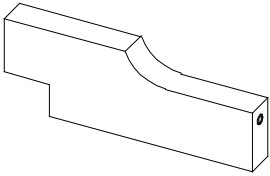
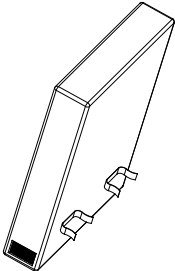
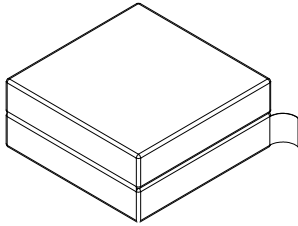
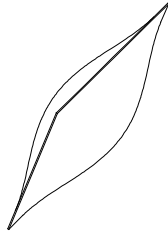
<p><b>A</b>    <b>x1</b></p>  <p>Left Armrest</p>	<p><b>B</b>    <b>x1</b></p>  <p>Right Armrest</p>	<p><b>C</b>    <b>x1</b></p>  <p>Seat Frame &amp; Backrest</p>	<p><b>D</b>    <b>x1</b></p>  <p>Back Stretcher</p>
<p><b>E</b>    <b>x2</b></p>  <p>Bottom Stretcher</p>	<p><b>F</b>    <b>x3</b></p>  <p>Front Leg</p>	<p><b>G</b>    <b>x4</b></p>  <p>Support Leg</p>	<p><b>H</b>    <b>x2</b></p>  <p>Back Linker Stretcher</p>
<p><b>I</b>    <b>x3</b></p>  <p>Back Cushion</p>	<p><b>J</b>    <b>x3</b></p>  <p>Seat Cushion</p>	<p><b>K</b>    <b>x3</b></p>  <p>Pillow</p>	

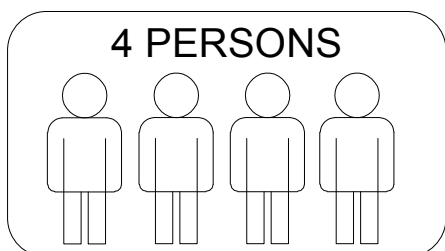

# HARDWARE LIST

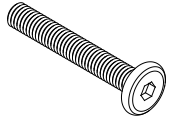
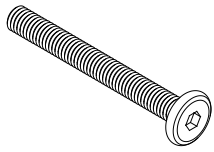
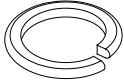
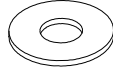
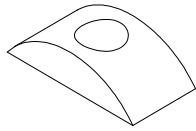
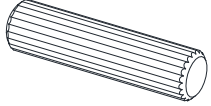
①	x18	②	x8	③	x20	④	x20	⑤	x6	⑥	x19
											
1/4" x 40mm Bolt		1/4" x 50mm Bolt		1/4" x D11mm Spring Washer		1/4" x D16mm Flat Washer		14x28x7 Washer		D10x40 Wood Dowel	

# TOOL LIST

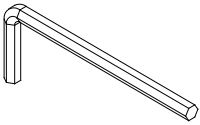
⑦	x1
	
M4 Allen Key	

# HARDWARE SPARE LIST

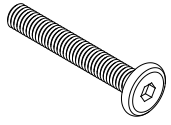
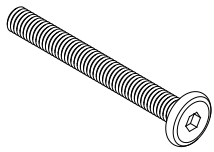
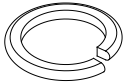
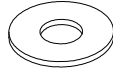
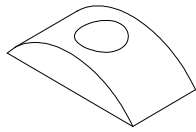
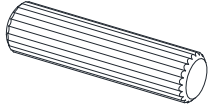
①	x2	②	x1	③	x2	④	x2	⑤	x1	⑥	x1
											
1/4" x 40mm Bolt		1/4" x 50mm Bolt		1/4" x D11mm Spring Washer		1/4" x D16mm Flat Washer		14x28x7 Washer		D10x40 Wood Dowel	

Be sure to check all packing material carefully for small parts, which may have come loose inside the carton during shipment.

# EXPLOSIVE VIEW

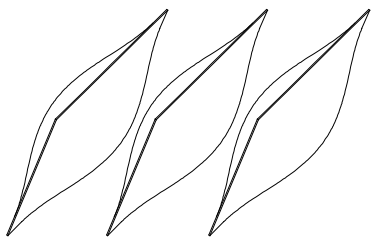
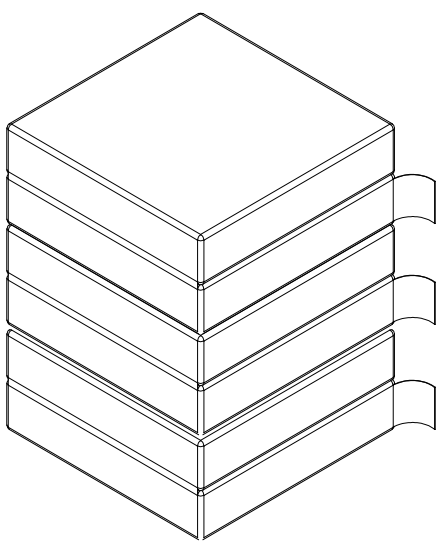
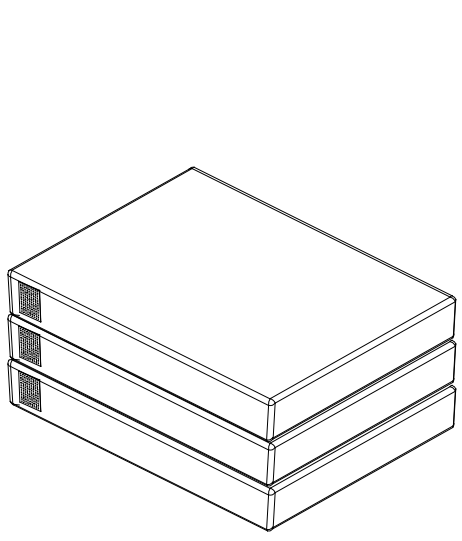
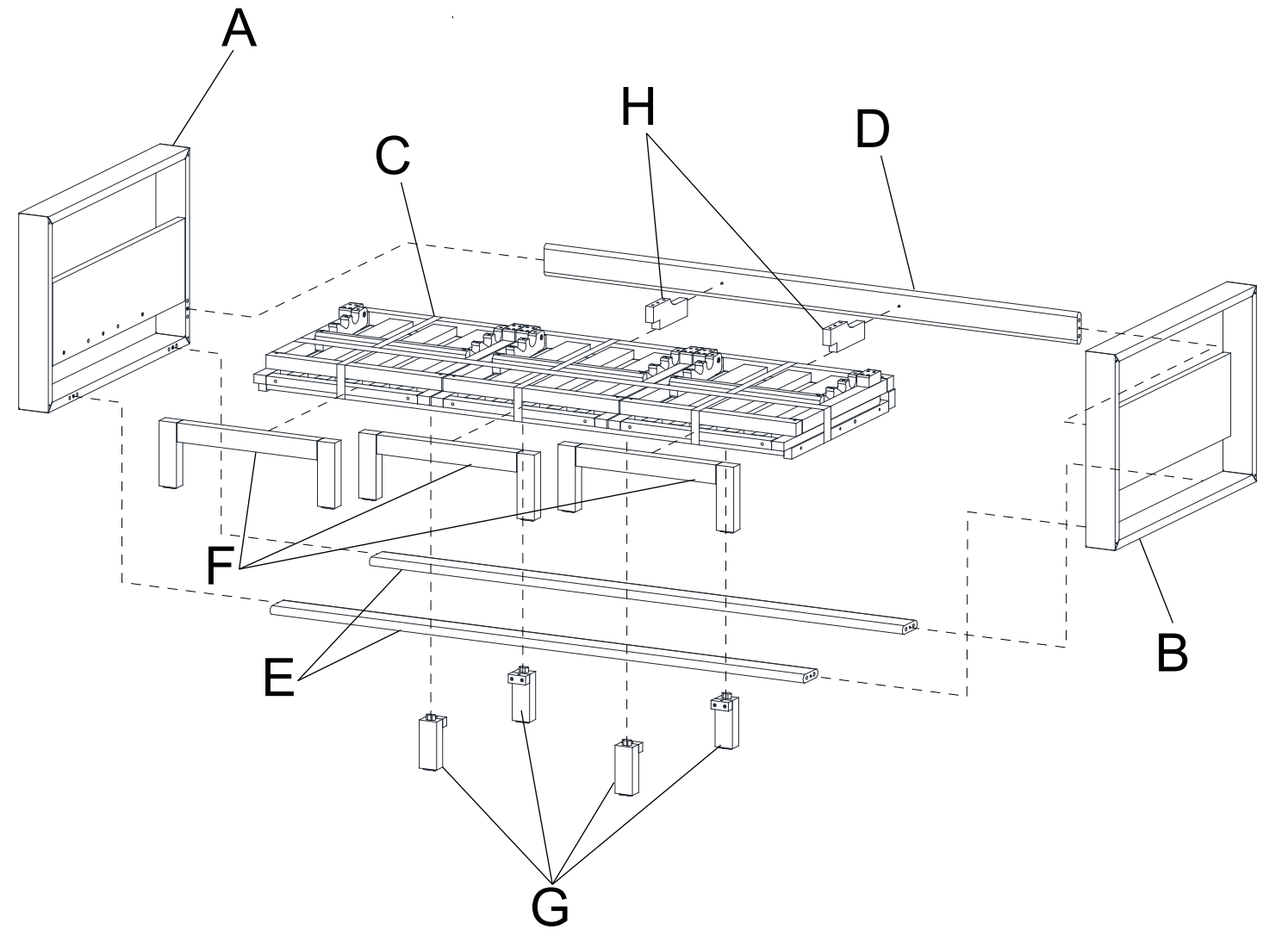

I

J

K

# ASSEMBLY INSTRUCTIONS

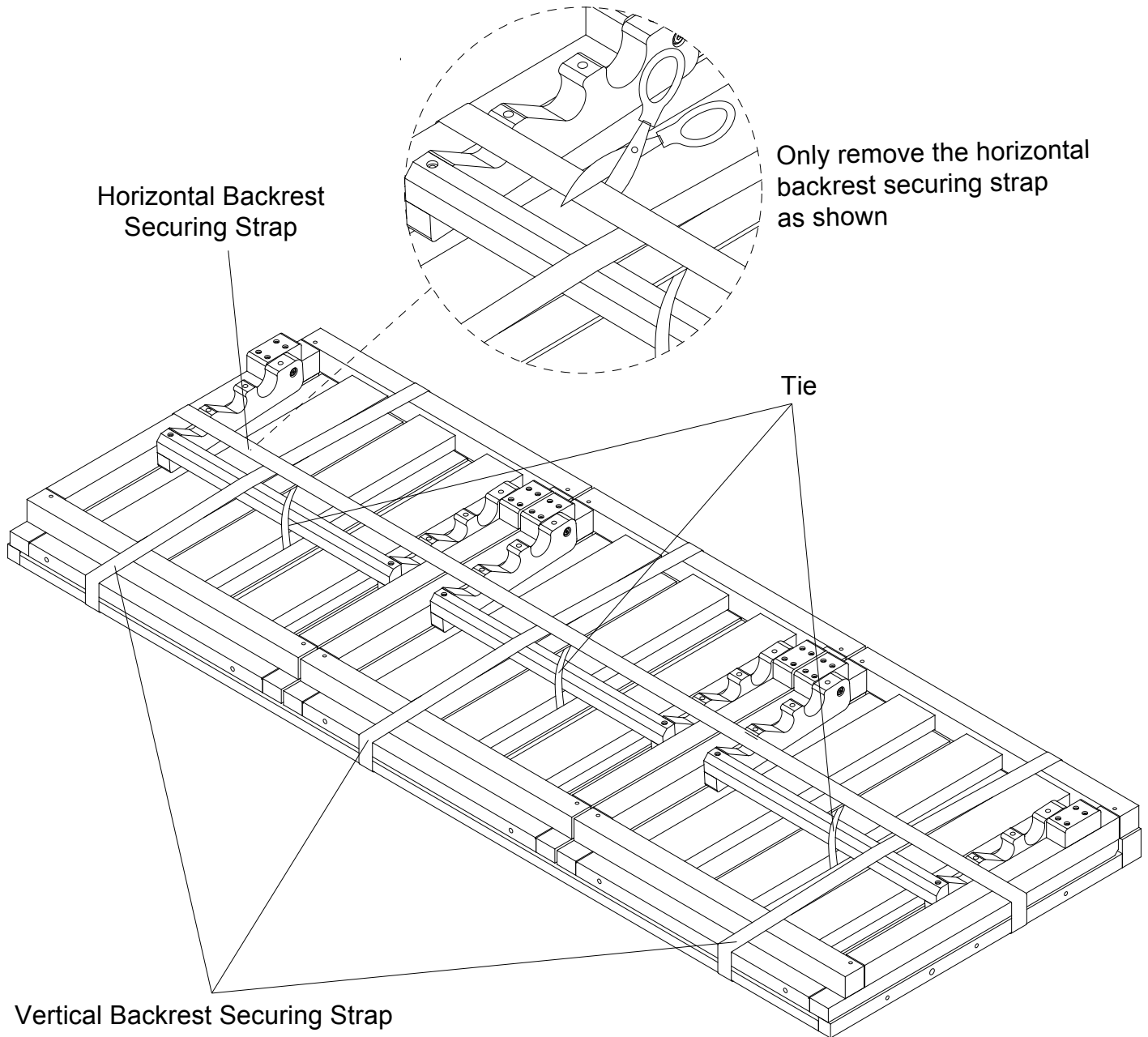



**WARNING NOTE:** Before starting, make sure the vertical backrest securing strap and the adjustment bar tie are not cut until STEP-5 is completed.

# ASSEMBLY INSTRUCTIONS

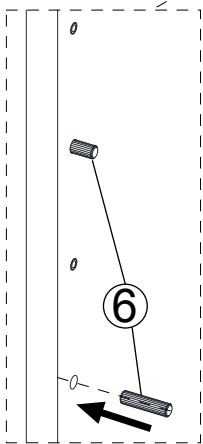
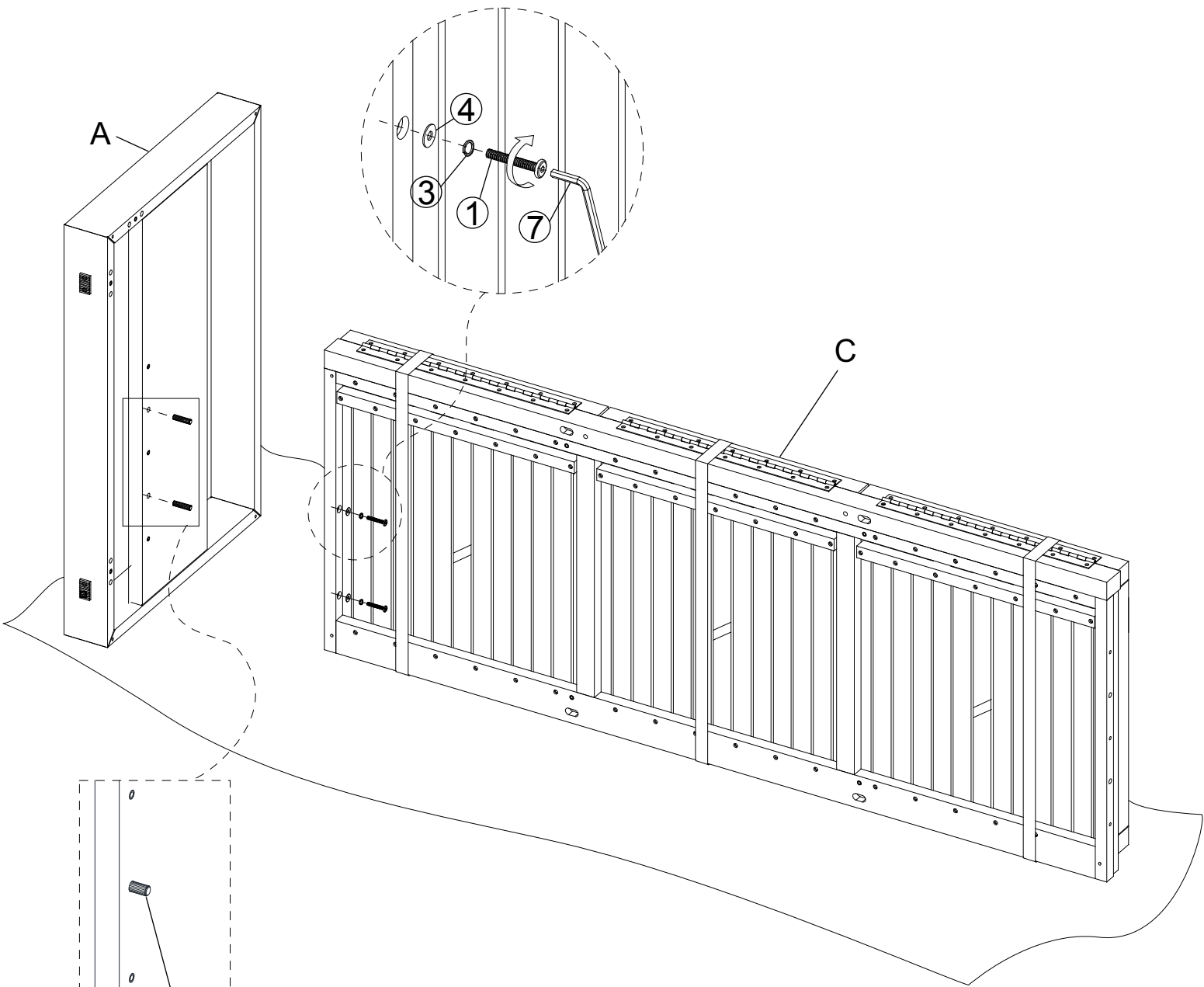
## STEP-1

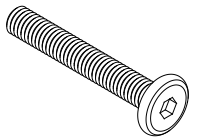

- Attach Wood Dowel (6) to Left Armrest (A) then place Seat Frame & Backrest (C) at Wood Dowel holes position as shown
- Attach Seat Frame & Backrest (C) to Left Armrest (A), use Flat Washer (4), Spring Washer (3) and Bolt (1) with Allen Key (7) as shown
- **Attention: Tighten Bolts (1) 50%.**

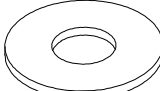
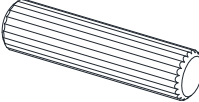
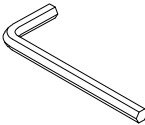
①	x2	③	x2	④	x2	⑥	x2	⑦	x1
									
1/4" x 40mm		1/4" x D11mm		1/4" x D16mm		D10x40		M4	
Bolt		Spring Washer		Flat Washer		Wood Dowel		Allen Key	

# ASSEMBLY INSTRUCTIONS

## STEP-2

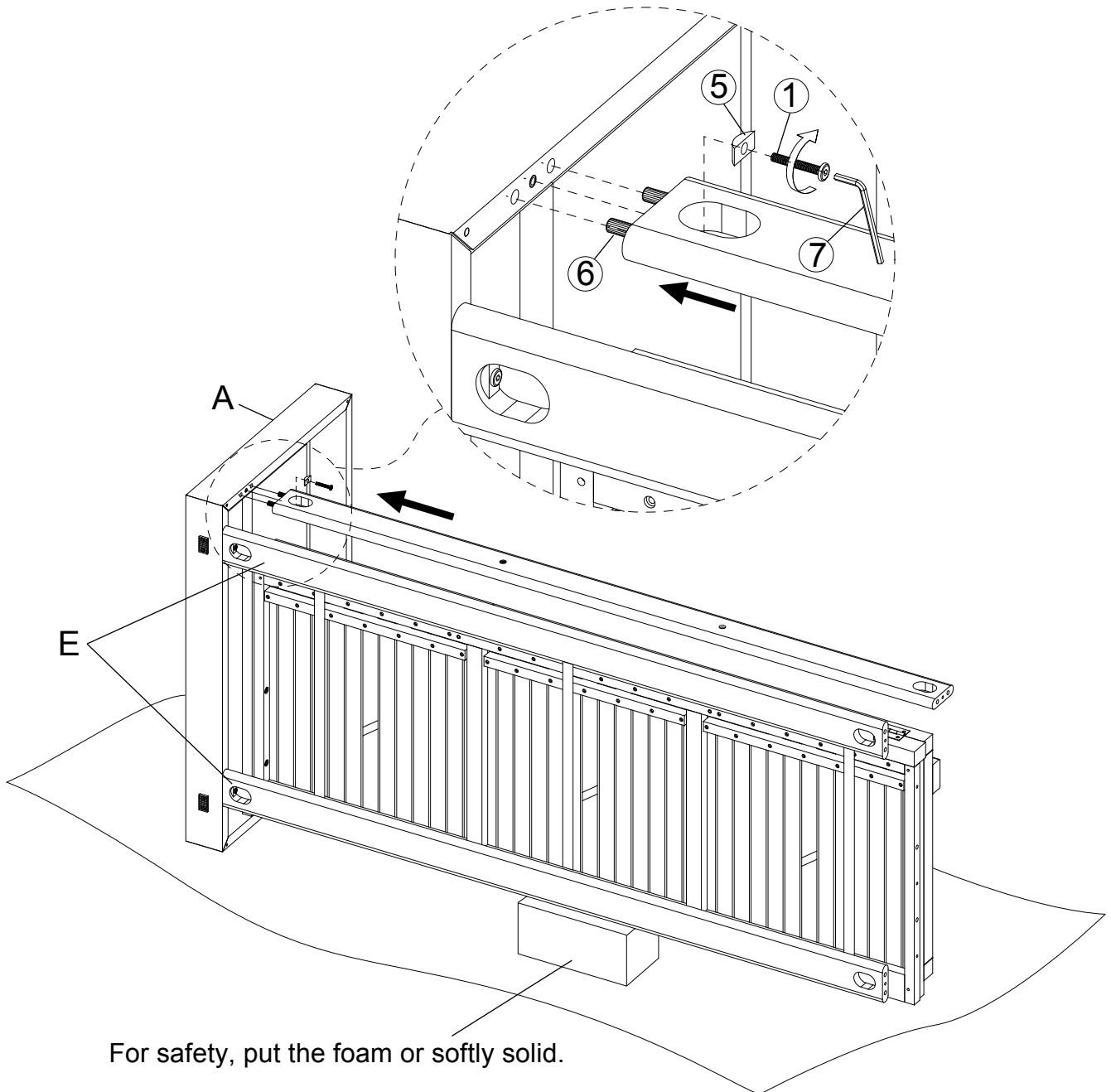

For safety, put the foam or softly solid.

- Attach Wood Dowel (6) to Back Stretcher (D) and Bottom Stretcher (E)
- Attach Back Stretcher (D) and Bottom Stretcher (E) to Left Armrest (A), use Washer (6) and Bolt (1) with Allen Key (7) as shown
- **Attention: Tighten Bolts (1) 50%**

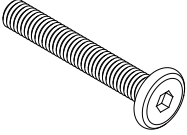
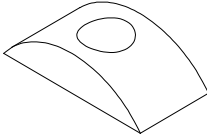
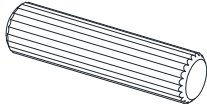
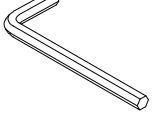

①	x3	⑤	x3	⑥	x6	⑦	x1
							
1/4" x 40mm Bolt		14x28x7 Washer		D10x40 Wood Dowel		M4 Allen Key	

# ASSEMBLY INSTRUCTIONS

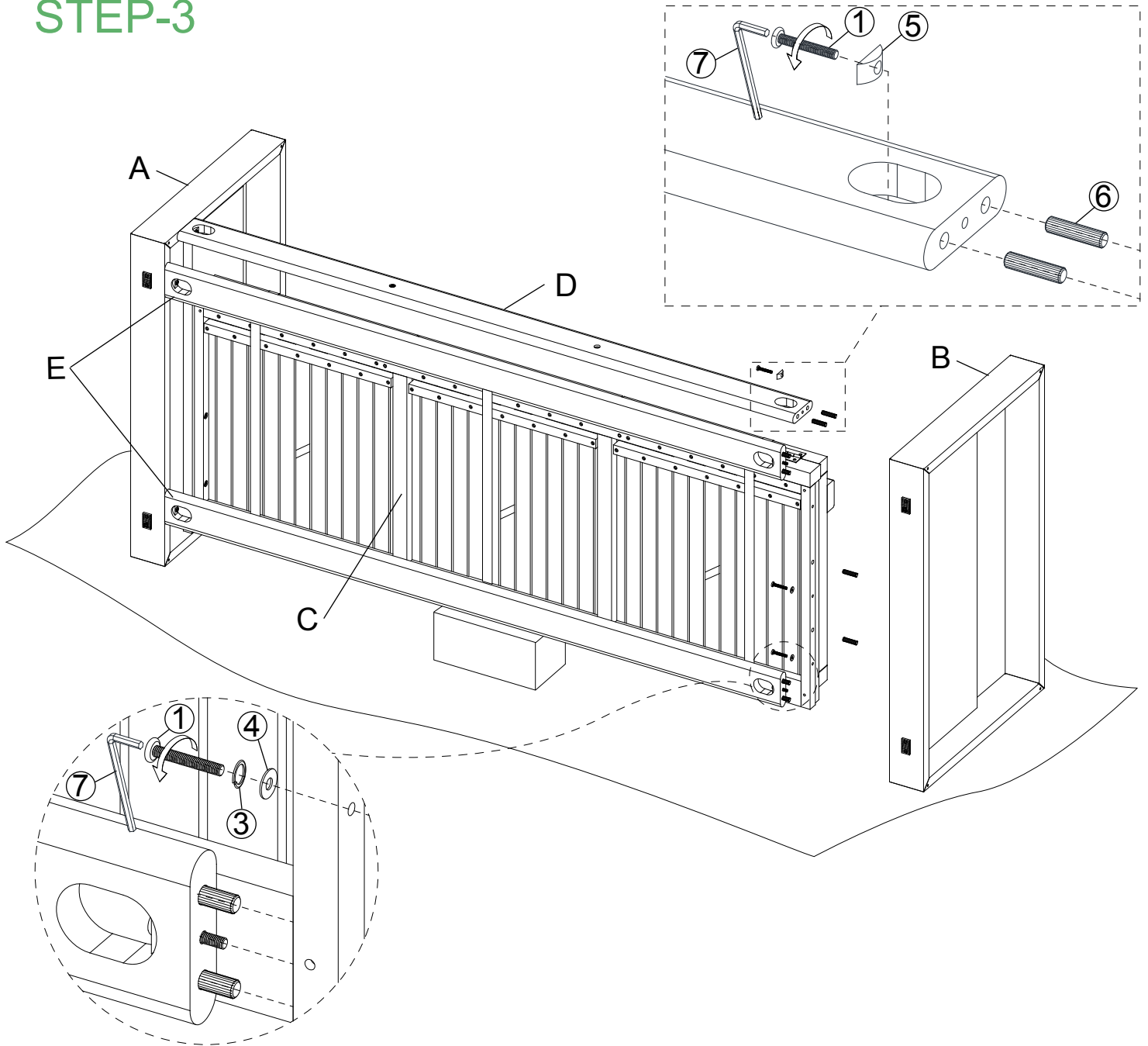
## STEP-3

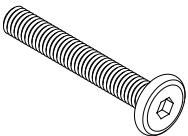

- Attach Right Armrest (B) to Seat Frame & Backrest (C), Back Stretcher (D) and Bottom Stretcher (E), use Flat Washer (4), Spring Washer (3), Washer (6) and Bolt (1) with Allen Key (7) \*SAME AS STEP 01 AND 02
- **Attention: Partially tighten Bolts (1) to 50%. Fully tighten after all parts are aligned.**

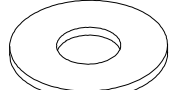
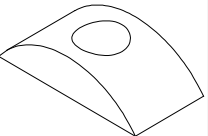
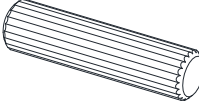
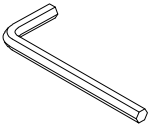

①	x5	③	x2	④	x2	⑤	x3	⑥	x8	⑦	x1
											
1/4" x 40mm		1/4" x D11mm		1/4" x D16mm		14x28x7		D10x40		M4	
Bolt		Spring Washer		Flat Washer		Washer		Wood Dowel		Allen Key	

# ASSEMBLY INSTRUCTIONS

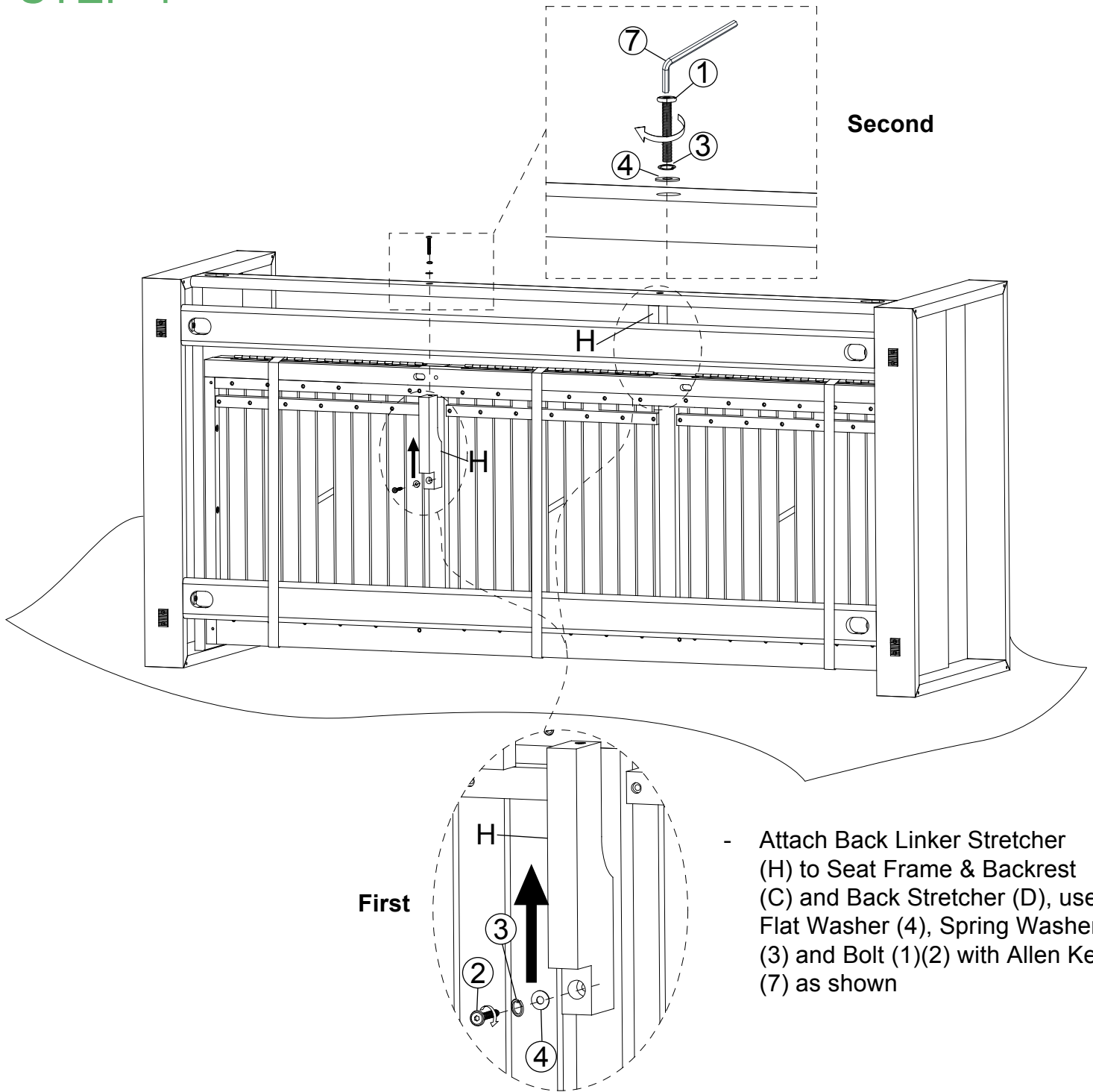
## STEP-4

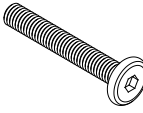
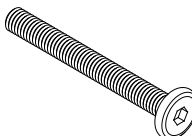

**Attention: Tighten Bolts (1)(2) 100%**

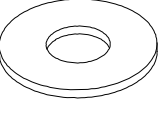
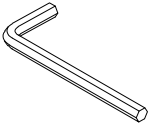
①	x2	②	x2	③	x4	④	x4	⑦	x1
									
1/4" x 40mm		1/4" x 50mm		1/4" x D11mm		1/4" x D16mm		M4	
Bolt		Bolt		Spring Washer		Flat Washer		Allen Key	

# ASSEMBLY INSTRUCTIONS

## STEP-5

- Attach Support Leg (G) to Seat Frame & Backrest (C), use Flat Washer (4), Spring Washer (3) and Bolt (1) with Allen Key (7) as shown

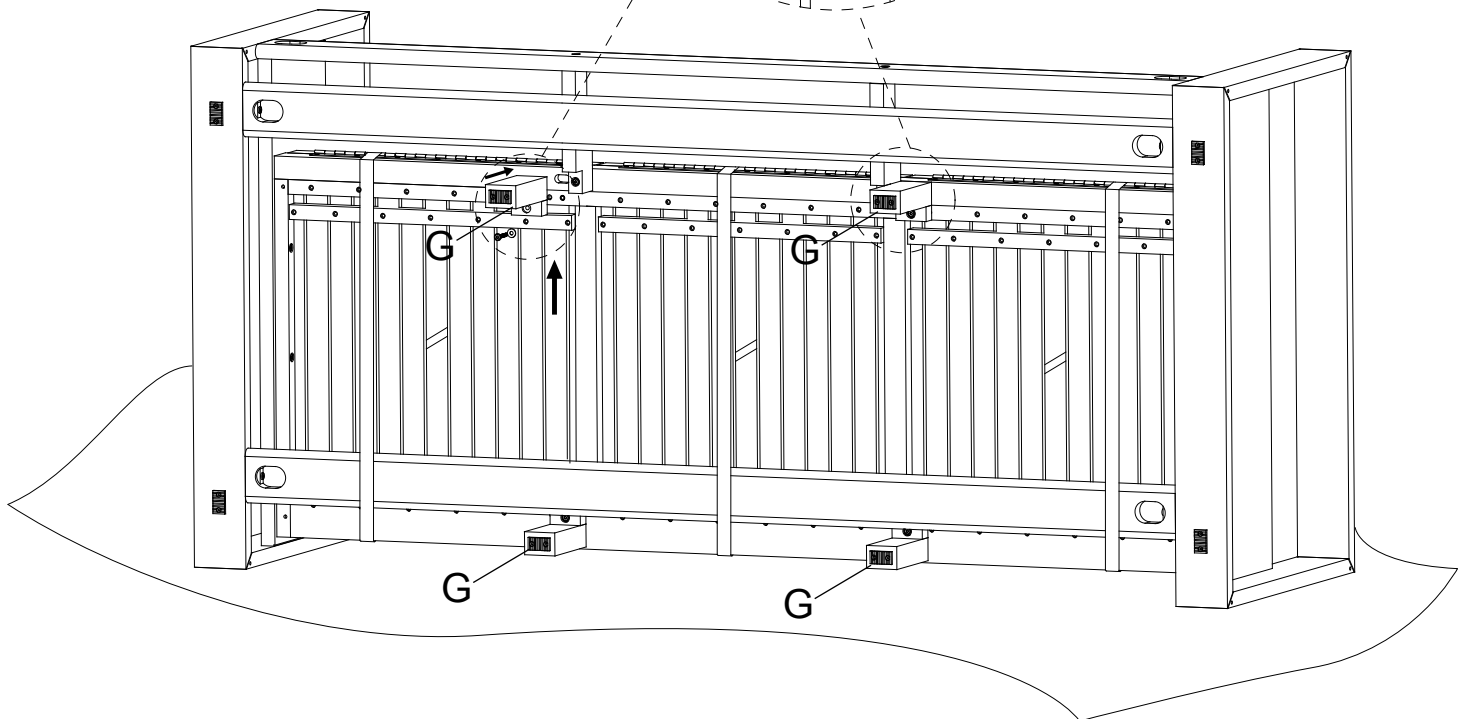
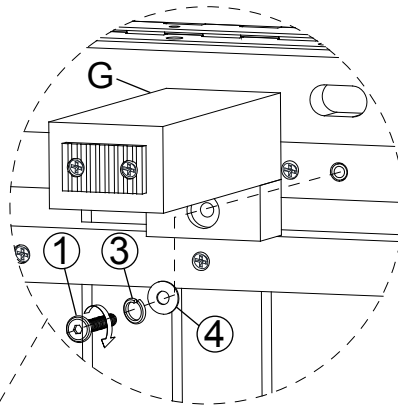

**Attention: Tighten Bolts (1) 100%**

①	x4	③	x4	④	x4	⑦	x1
1/4" x 40mm		1/4" x D11mm		1/4" x D16mm		M4	
Bolt		Spring Washer		Flat Washer		Allen Key	

# ASSEMBLY INSTRUCTIONS

## STEP-6

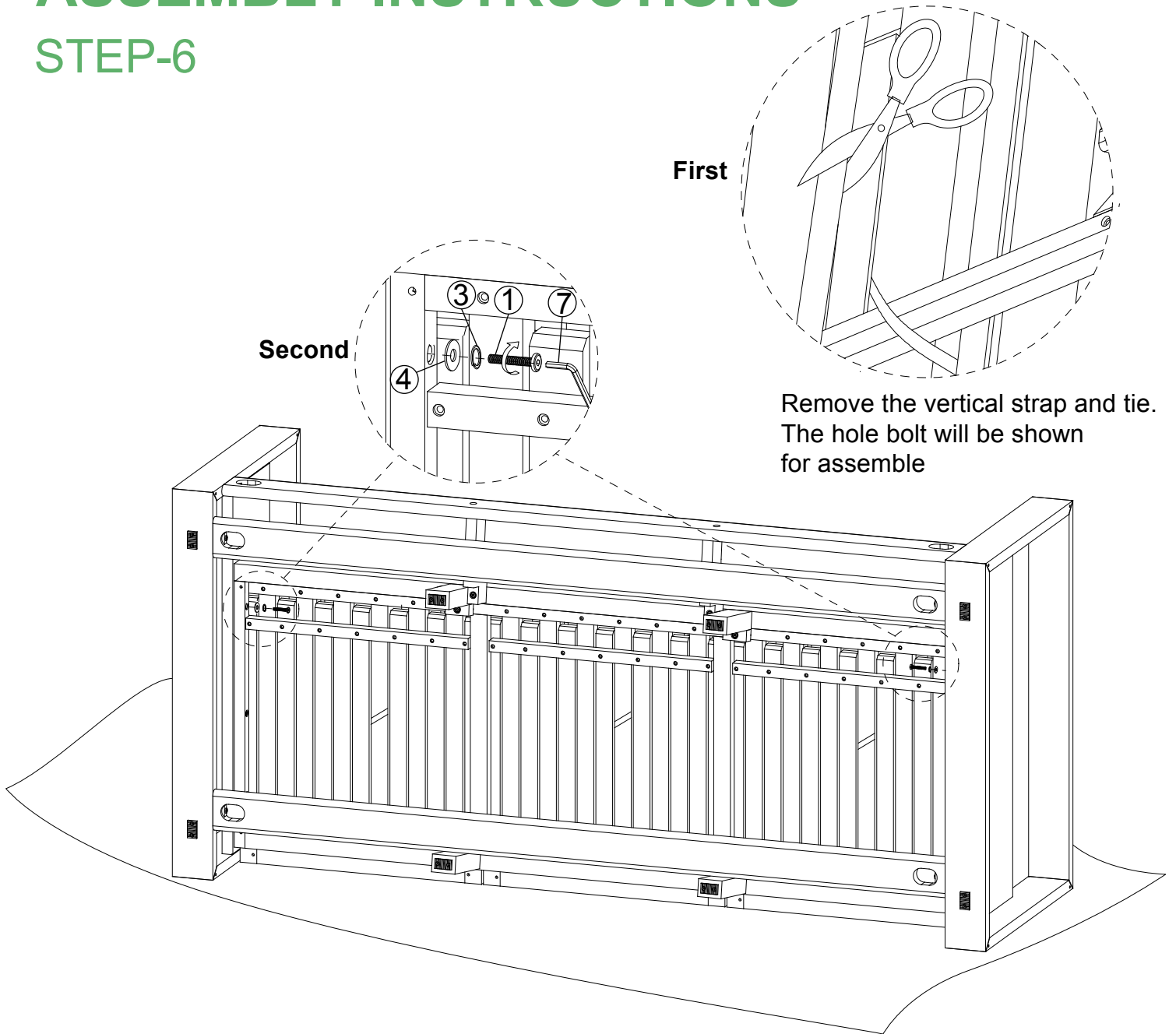

First

Remove the vertical strap and tie.  
The hole bolt will be shown  
for assemble

Second

- Remove the vertical strap and tie; the bolt hole will then be visible for assembly
- Tighten Seat Frame & Backrest (C) to Left Armrest (A) and Right Armrest (B), use Flat Washer (4), Spring Washer (3) and Bolt (1) with Allen Key (7) as shown

- **Attention: Fully tighten Bolts (1) to 100%.**

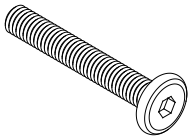
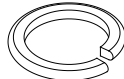
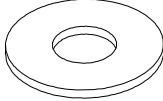
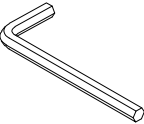
①	x2	③	x2	④	x2	⑦	x1
							
1/4" x 40mm		1/4" x D11mm		1/4" x D16mm		M4	
Bolt		Spring Washer		Flat Washer		Allen Key	

# ASSEMBLY INSTRUCTIONS

## STEP-7

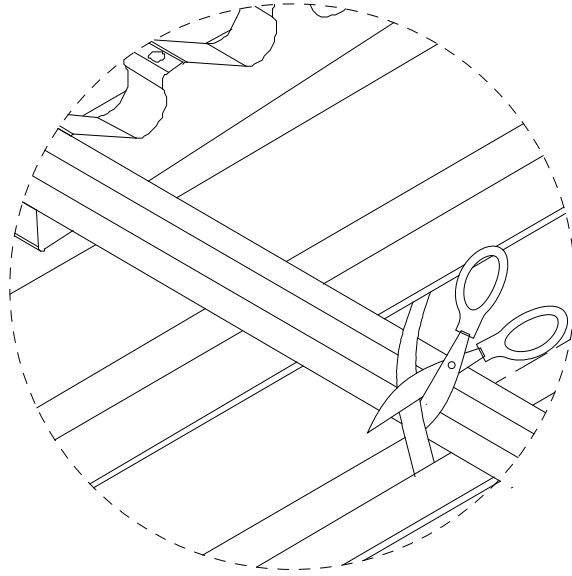

Remove the adjustment bar tie,  
then open the backrest as shown

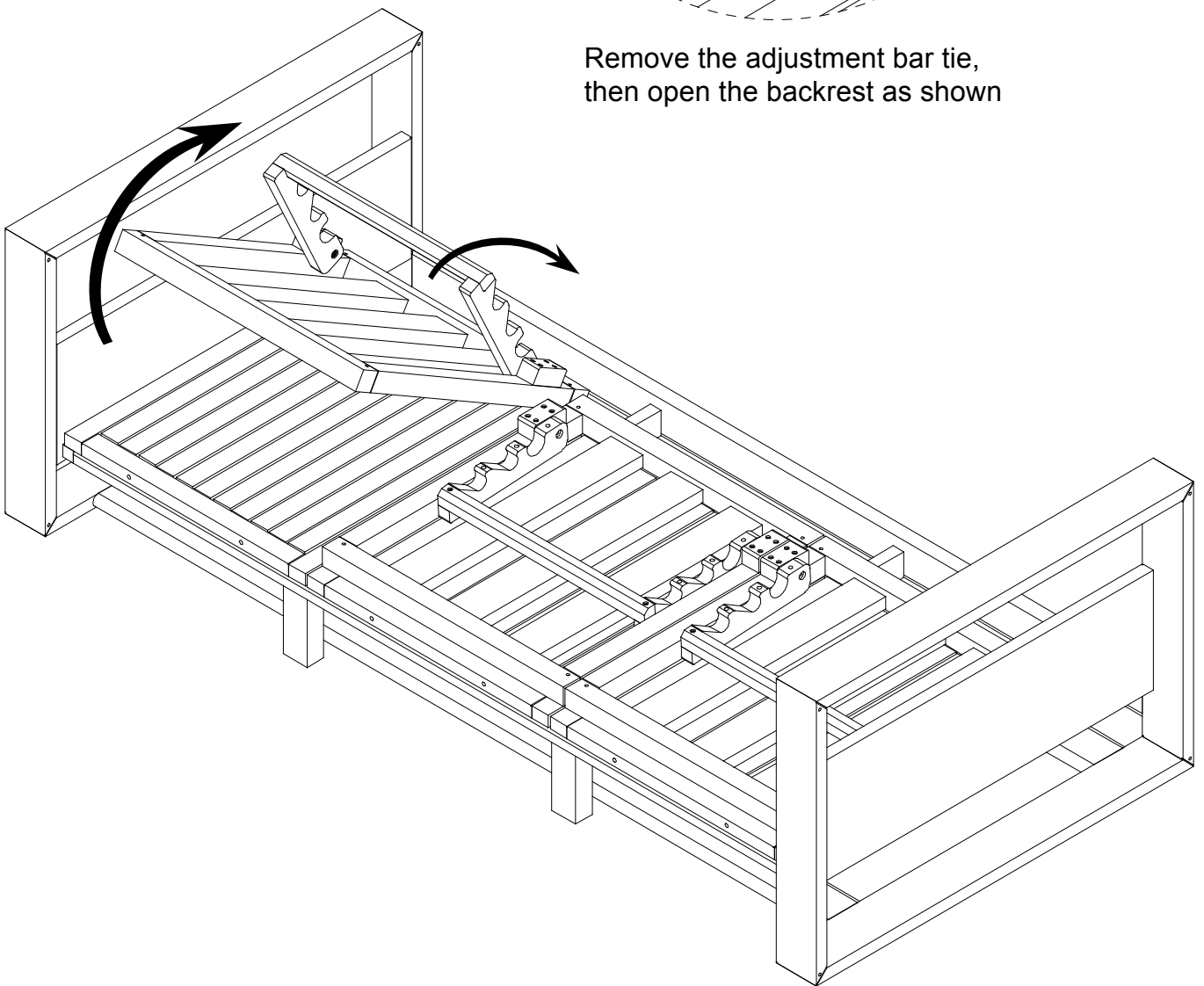

# ASSEMBLY INSTRUCTIONS

## STEP-8

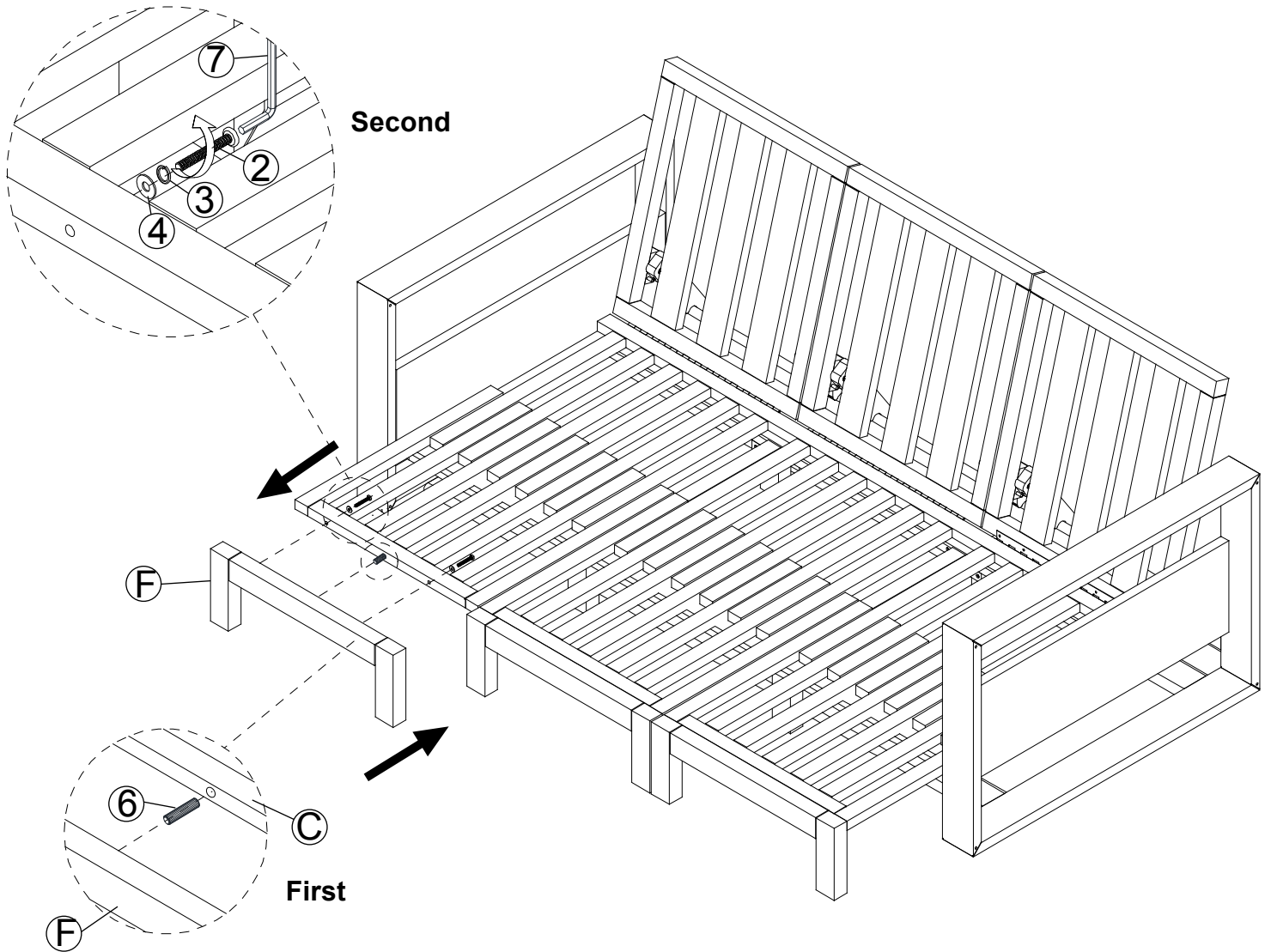

- Pull out Seat Frame (C)
- Attach Wood Dowel (6) to Seat Frame (C), then attach Front Leg (F) to Seat Frame (C), use Flat Washer (4), Spring Washer (3) and Bolt (1) with Allen Key (7) as shown

- **Attention: Fully tighten Bolts (2) to 100%.**

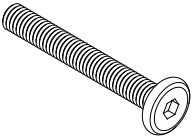
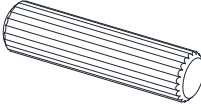
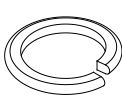
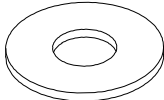
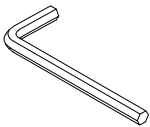
②	x6	⑥	x3	③	x6	④	x6	⑦	x1
									
1/4" x 50mm		D10x40		1/4" x D11mm		1/4" x D16mm		M4	
Bolt		Wood Dowel		Spring Washer		Flat Washer		Allen Key	

# ASSEMBLY INSTRUCTIONS

## STEP-9

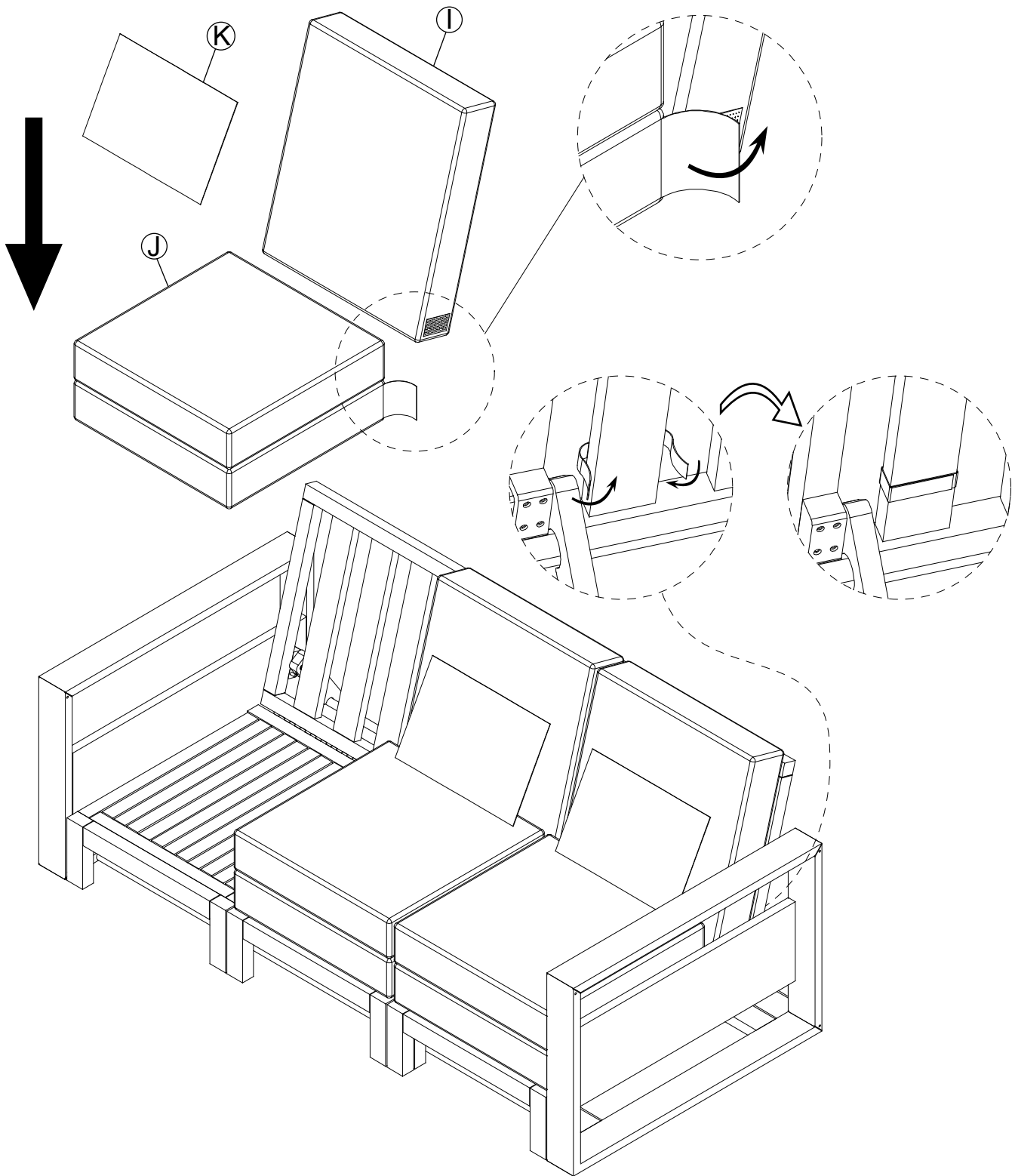

- Put Seat Cushion (J) to Seat Frame (C) (Note: Make sure to put the tape side of the cloth towards the back).
- Put Back Cushion (I) behind Seat Cushion (J) and tape them together with the tape.
- Fix Back Cushion (I) to Backrest Frame (C) by fastening the strip of felt tape behind the cushion to the center vertical bar of Backrest Frame (C).
- Put Pillow (K) above Seat Cushion (J)

# ASSEMBLY INSTRUCTIONS

## STEP-10

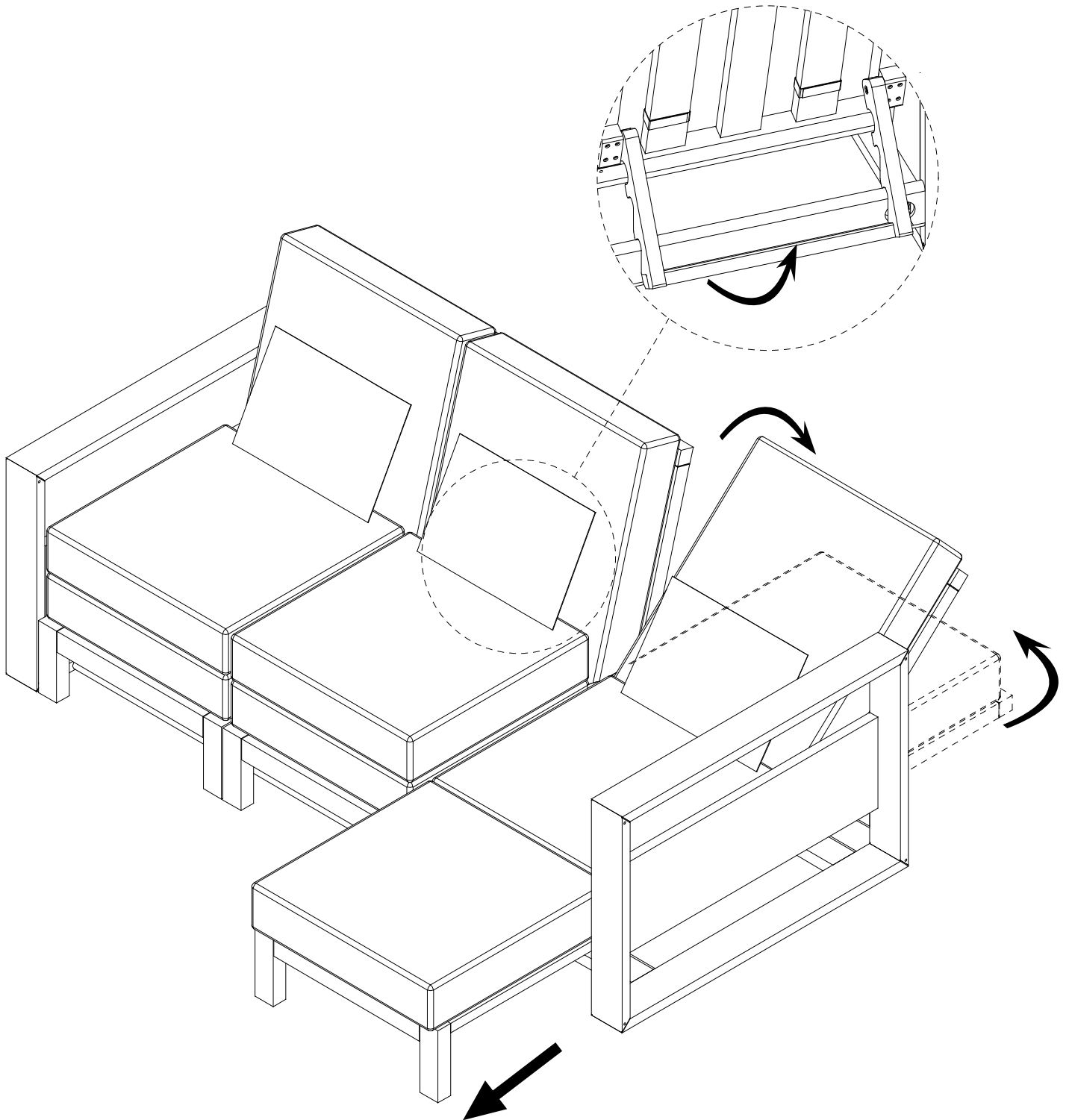

\*\*\*The product can adjust the backrest with 3 levels

# WARRANTY

1. We strive to offer high-quality products, and we also try our best to satisfy each and every customer that orders from us with product or service as needed.
2. We provide 30 days warranty starting from the time you receive the item. Each customer must provide a record of their order such as the order number, or item receipt for any items that are out of the warranty period you may also still receive.
3. Replacement parts by purchasing them with our company if they are available.

Appreciate your purchasing from us.  
Pop up your life by our furniture piece!