

Assembly Instruction

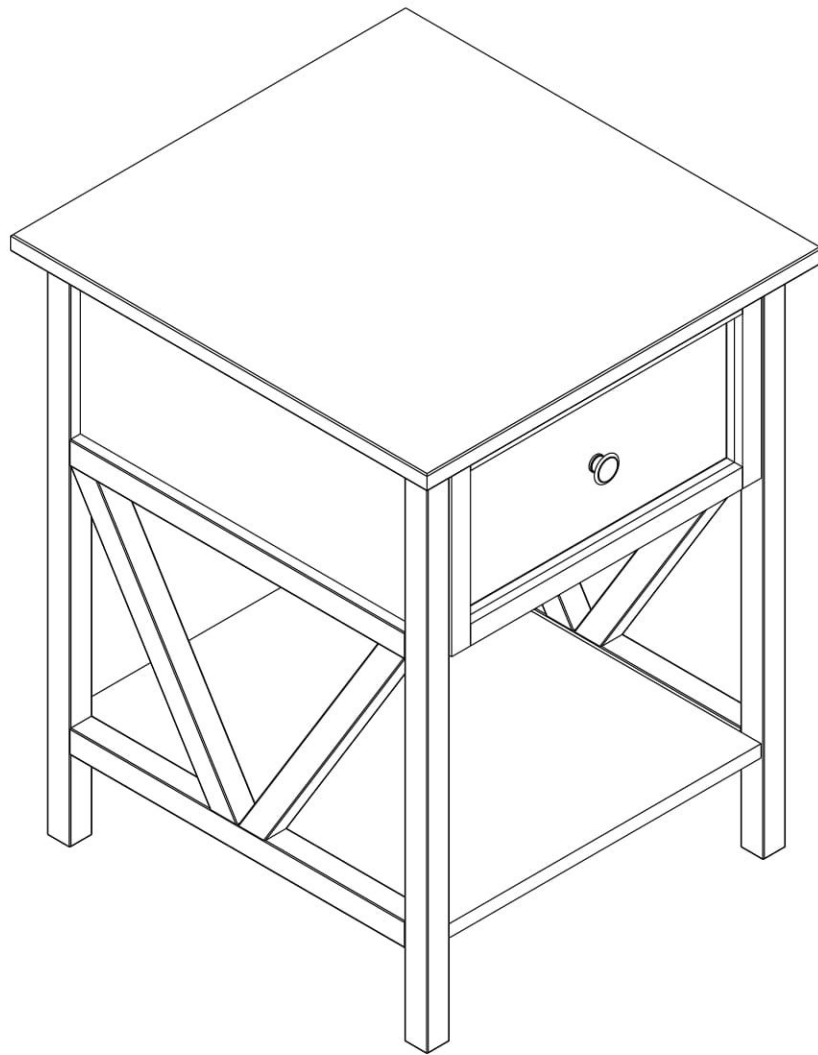

General Assembly Guidelines

- I. Ensure that all parts and hardware are available before beginning assembly.
- II. Follow each step carefully to ensure the proper assembly of this product.
- III. Two people are recommended for ease in the assembly of this product.
- IV. The three main types of hardware used to assemble this product are : wood dowels , screws and bolts.
- V. A Phillips head screwdriver is required for the assembly of this product .

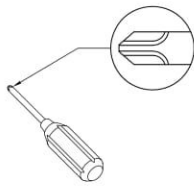



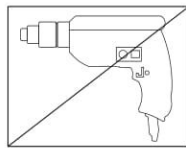

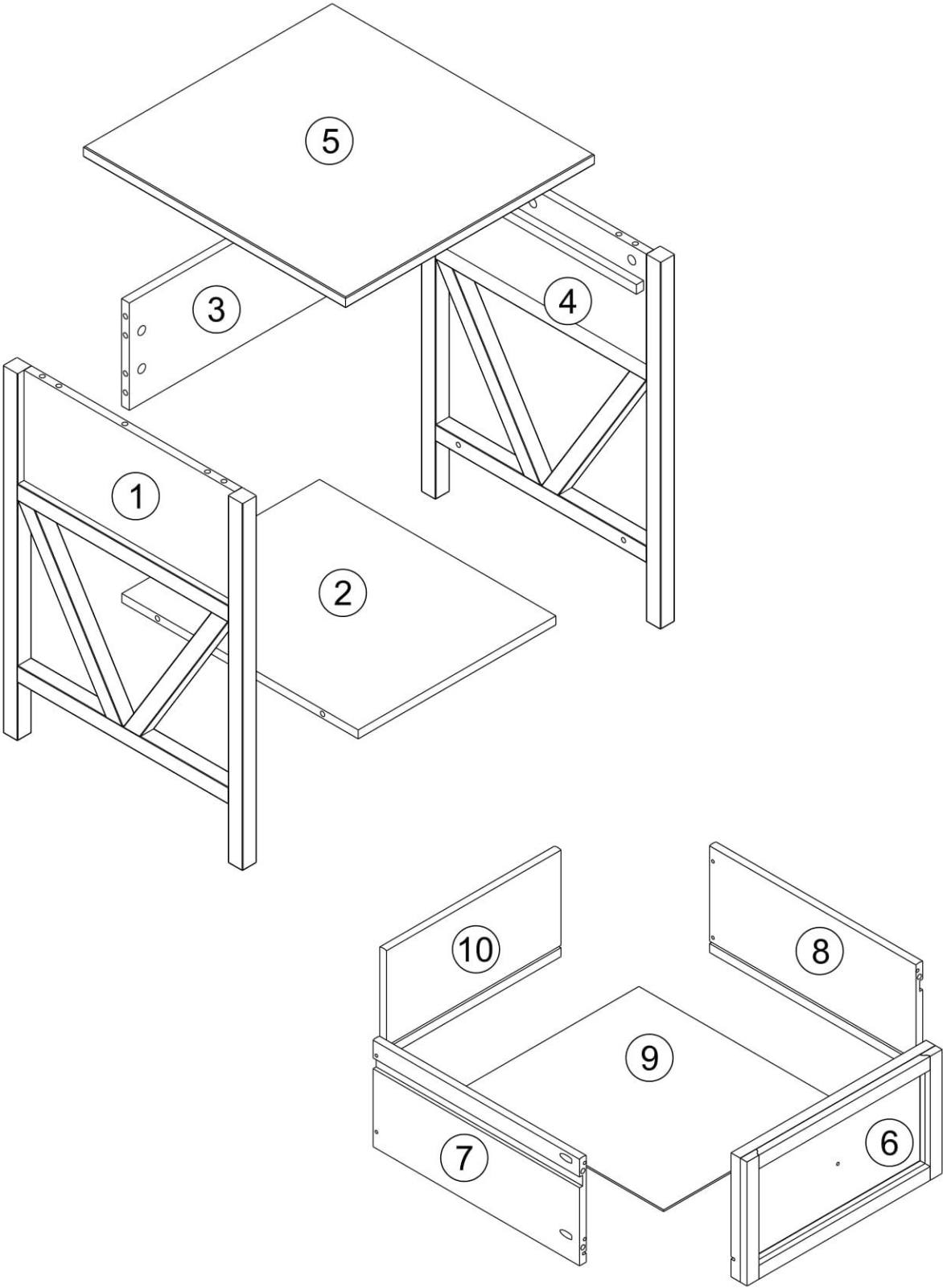

- VI. Power tools should not be used to assemble this product .



Parts List

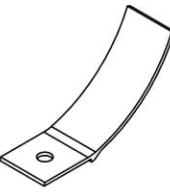

Hardware List

A		Ø 5,5x28mm	Cam Bolt	10 pcs
B		Ø 14x14mm	Cam Lock	10 pcs
C		M4x25mm	Screw	01 pc
D		Ø 4,0x30 mm	Screw	14 pcs
E		Ø 3,0x16 mm	Screw	01 pc
F		Ø 8,0x30 mm	Wood dowel	16 pcs
G			Knob	01 pc
H			Drawer Limiter	01 pc

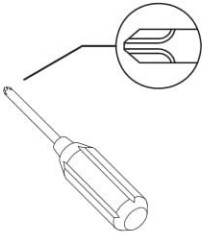

Philips head screwdriver required for assembly
(not included)

*The hardware quantities listed above are required for proper assembly.
Some extra hardware may also have been included.*

Step 1 Insert Cam Bolts (A) into parts 1 and 4; Insert Wood Dowels (F) into parts 1, 2, 3, 4, 7 and 8.

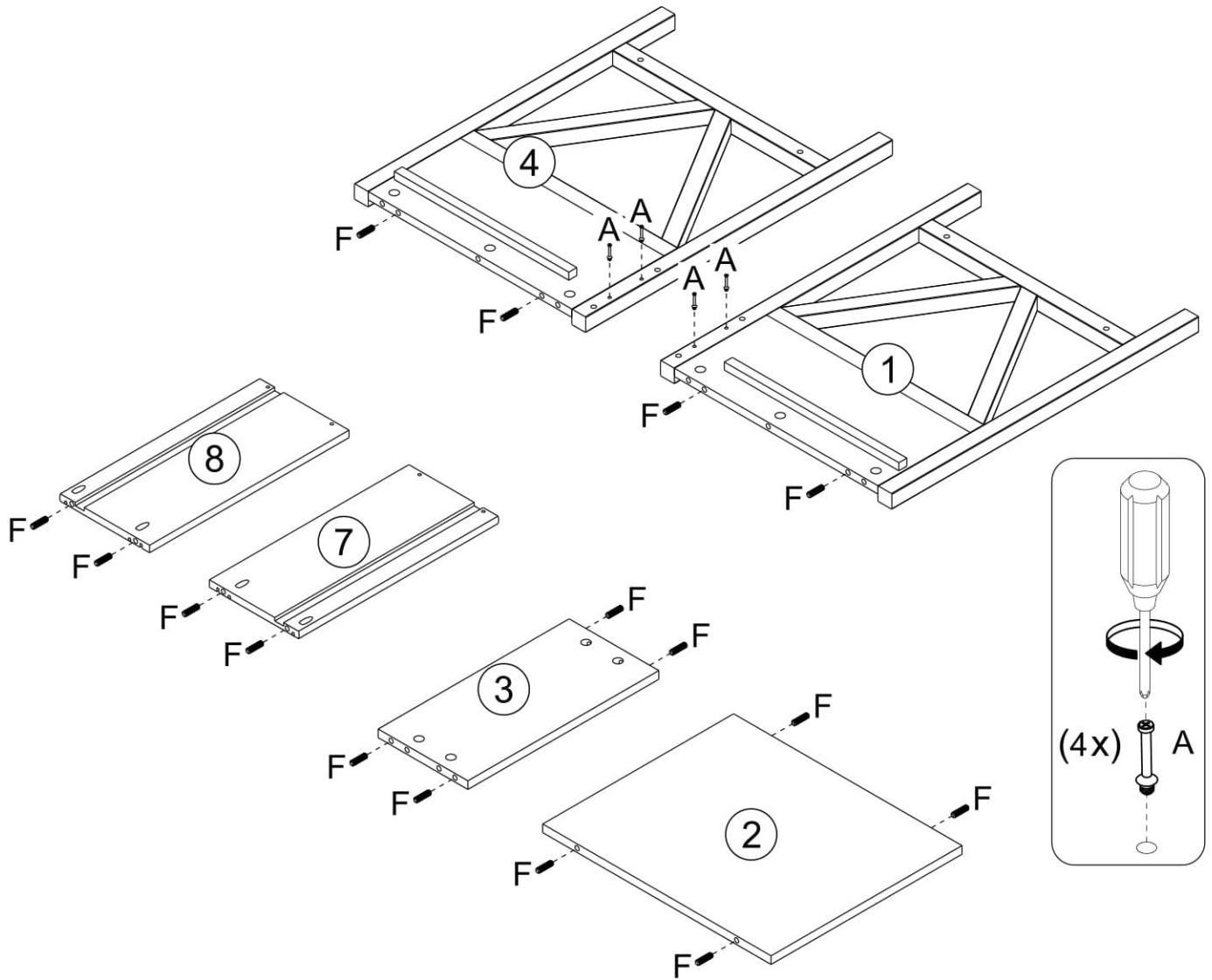

Step 2 Insert Cam Bolts (A) into part 5; Attach Drawer Limiter (H) to part 5 using Screw (E).

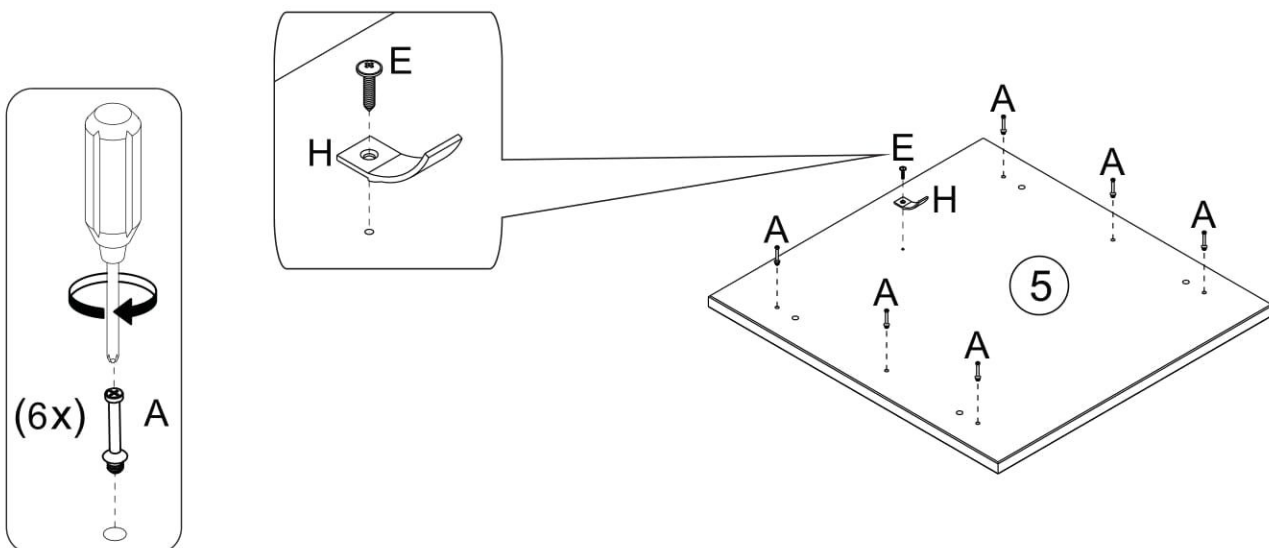

Step 3

Attach parts 2 and 3 to part 1 using Screw (D) on part 2 and fastening part 3 with Cam Locks (B).

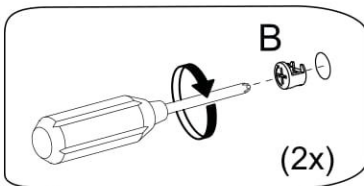
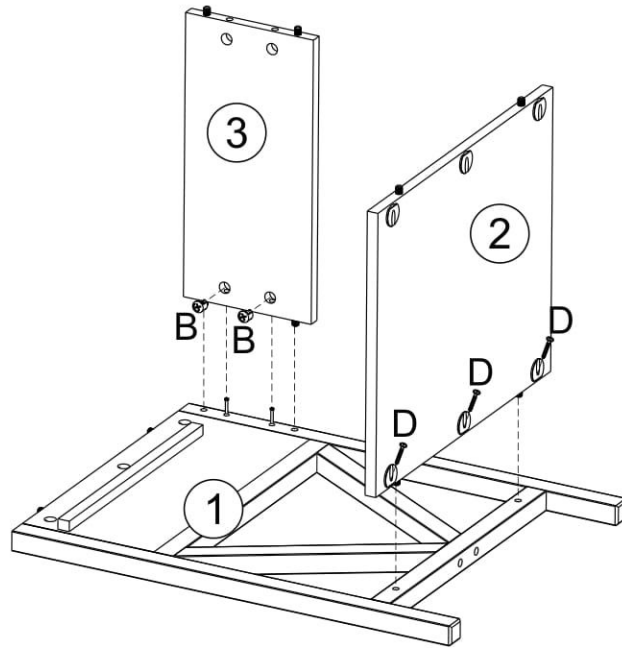

(2x)

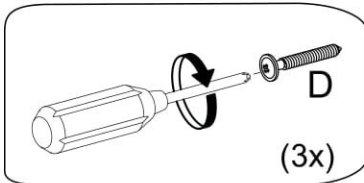

(3x)

Step 4

Attach parts 1, 2, 3 to part 4 using Screw (D) and Cam Locks (B).

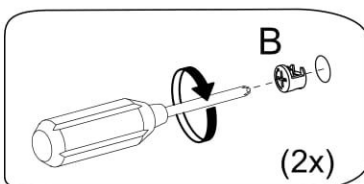
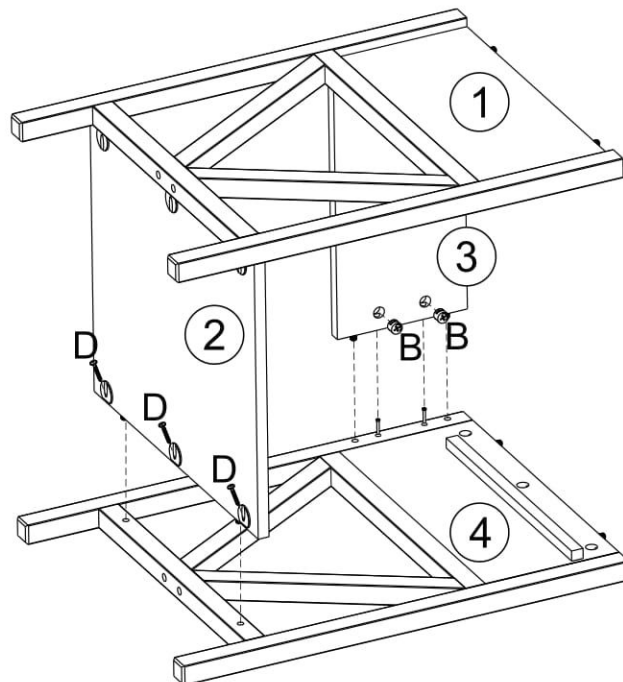

(2x)

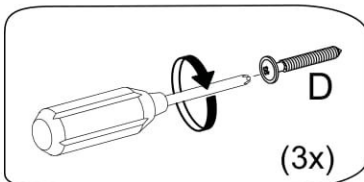

(3x)

Step 5

Attach the body to part 5 using Cam Locks (B).

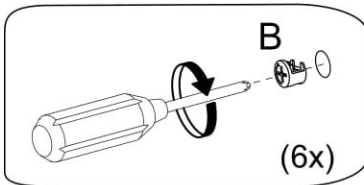
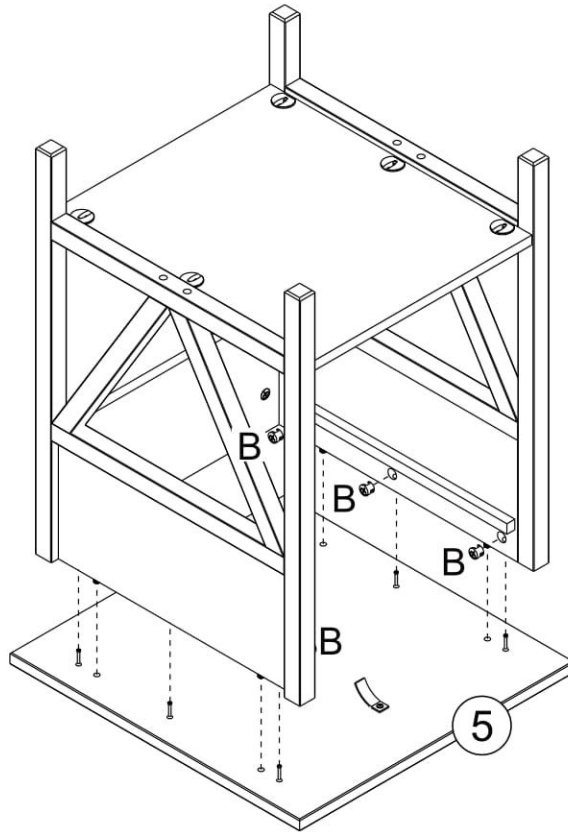

Step 6

Attach parts 7, 8 to part 6 using Screws (D); slide part 9 into place.

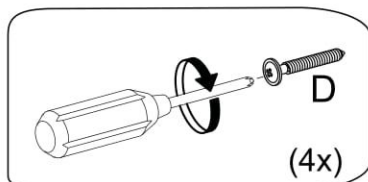
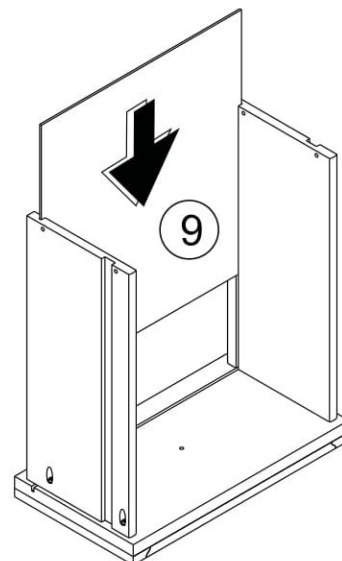
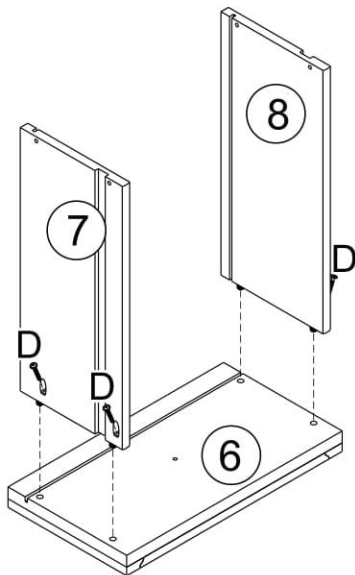

Step 7 Attach part 10 using Screws (D).

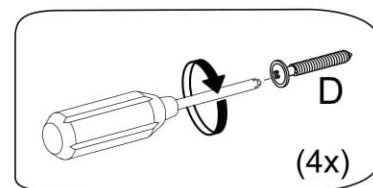
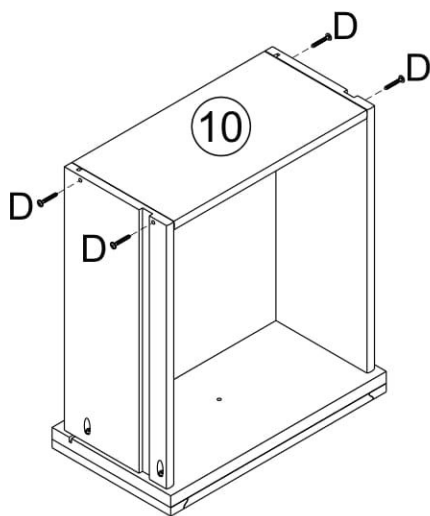

Step 8 Attach Knob (G) using Screw (C) and place drawer into place.

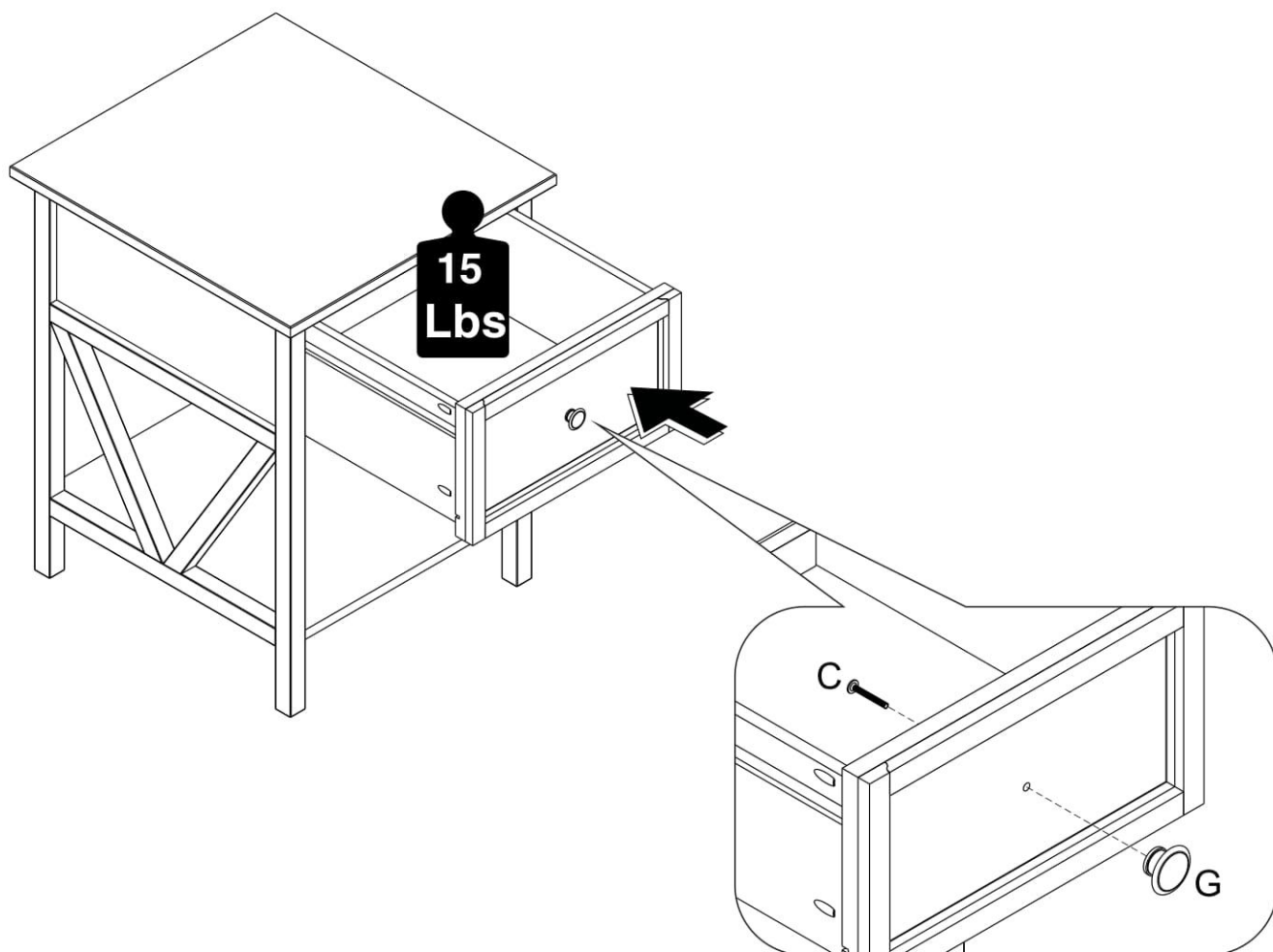

Final Assembly