

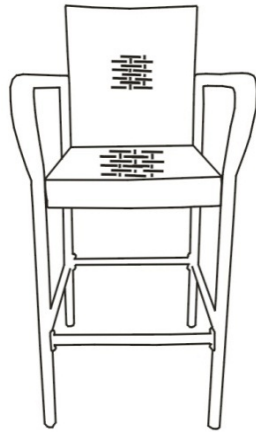





Assembly Instructions

Caution : You must read this before you proceed





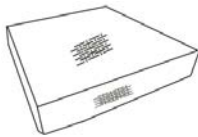

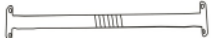
Barstool



Parts List

Label	Picture	Description	QTY
A		Backrest	1
B		Left Armrest	1
C		Right Armrest	1
D		Seat Panel	1
E		Front Foot Rest	1
F		Back Foot Rest	1

Hardware

Label	Picture	Description	QTY
①		Allen Key	1
②		Bolt (M6*45MM)	5
③		Bolt (M6*35MM)	6
④		Bolt (M6*20MM)	9
⑤		Bolt Cap	13
⑥		Washer	20

Assembly Preparation

Before Beginning Assembly:

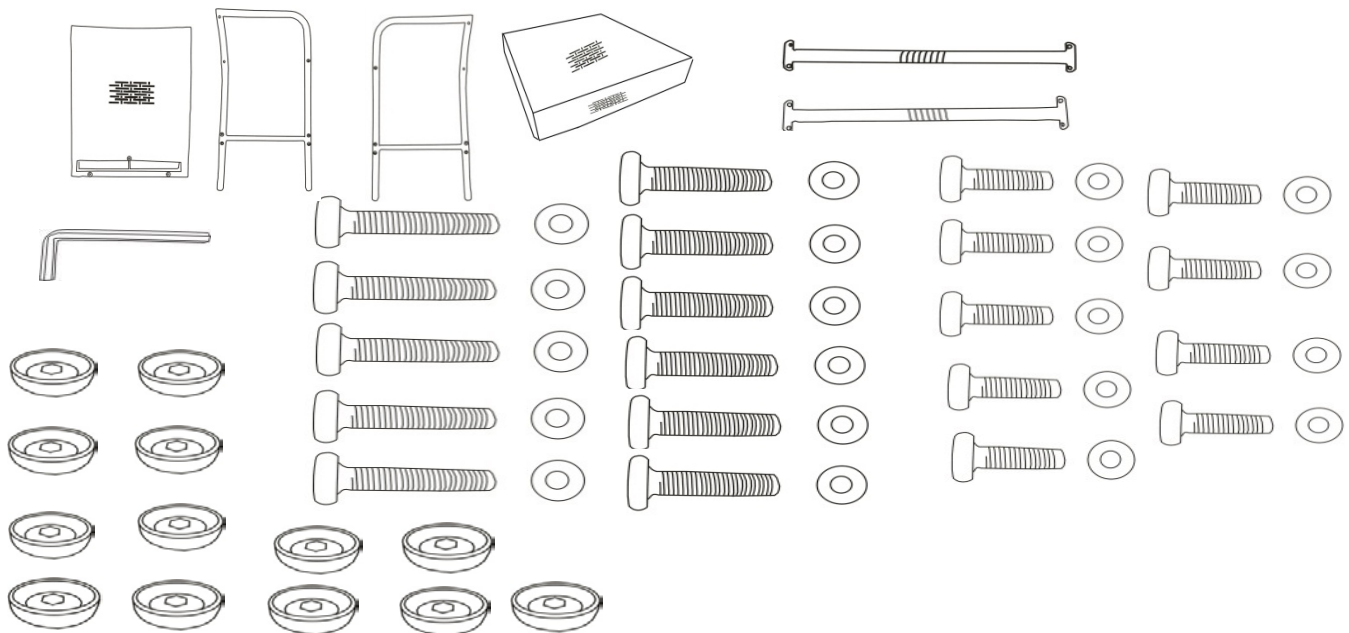

- Read instructions, cover to cover-



- Have 2 adults on hand for assembly-



- Do not assemble on flooring or carpet-



- Assemble on a clean non-marring surface (packing foam)-



- Save all packaging until finished-

Assembly Steps

Overview

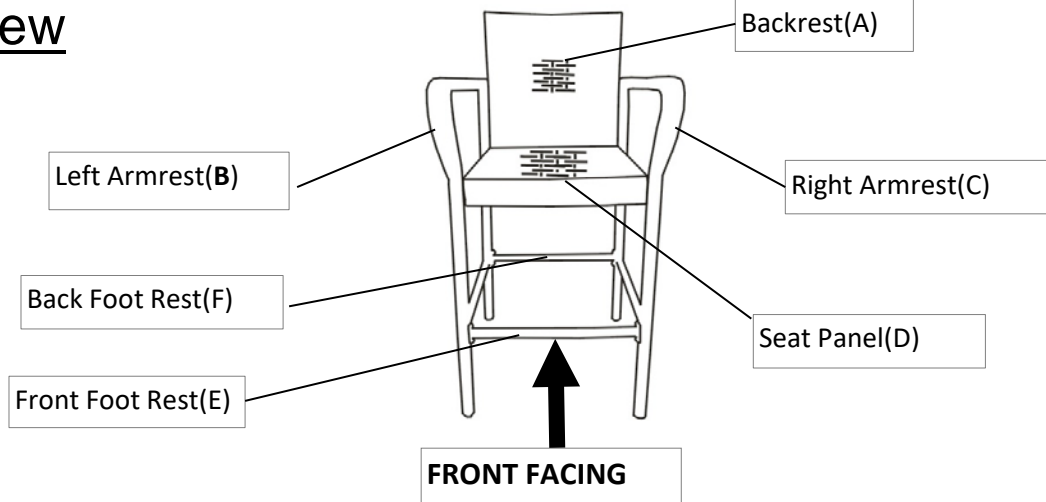

This Barstool has multiple parts and may require up to 30 minutes to assemble. To give you an overview of the Barstool parts, the above picture is to help you put the various parts into perspective. Please read through the instructions herebelow to familiarise yourself with the parts and steps before assembly.

Step 1

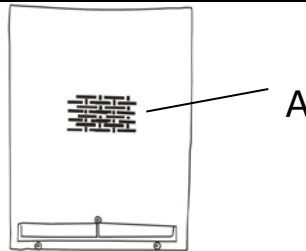

Open the carton and place all the parts onto a clean, non-marring surface. Place Backrest(A) on the ground, as shown in picture above.

Step 2

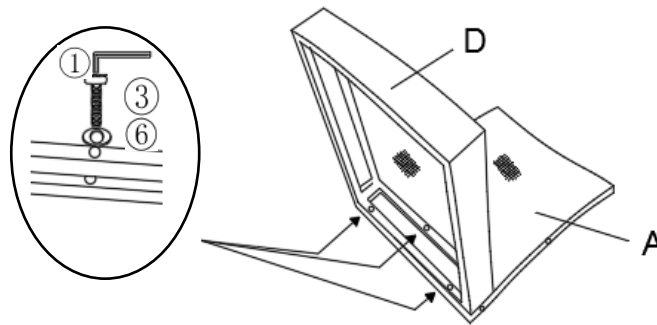

Attach Seat Panel(D) to Backrest(A) using Bolts(3) and Washers(6) with Allen Key(1). **DO NOT FULLY TIGHTEN THE BOLTS.**

ATTENTION: Occasionally some of the PE Wicker shifts and covers the mounting positions preventing easy assembly; The PE Wicker should never be cut, but moved away from the mounting positions.

Step 3

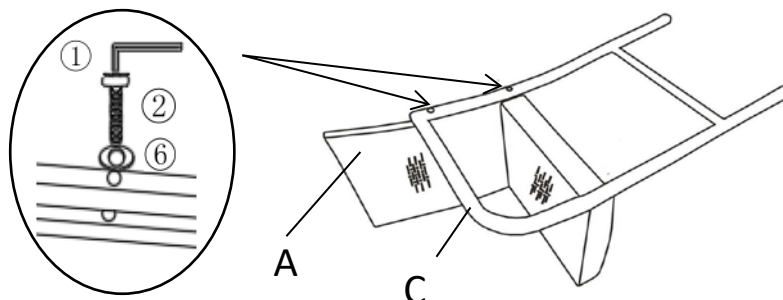

Attach the Right Armrest(C) to Backrest(A) using Bolts(2) and Washers(6) with Allen Key(1). **DO NOT FULLY TIGHTEN THE BOLTS.**

Step 4

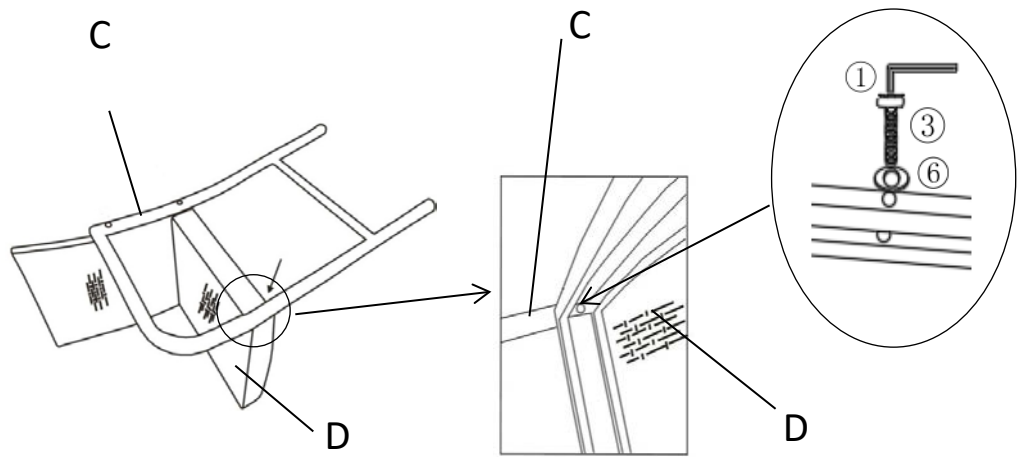

Attach the Right Armrest(C) to Seat(D) using Bolt(③) and Washer(⑥) with Allen Key(①).
DO NOT FULLY TIGHTEN THE BOLTS.

Step 5

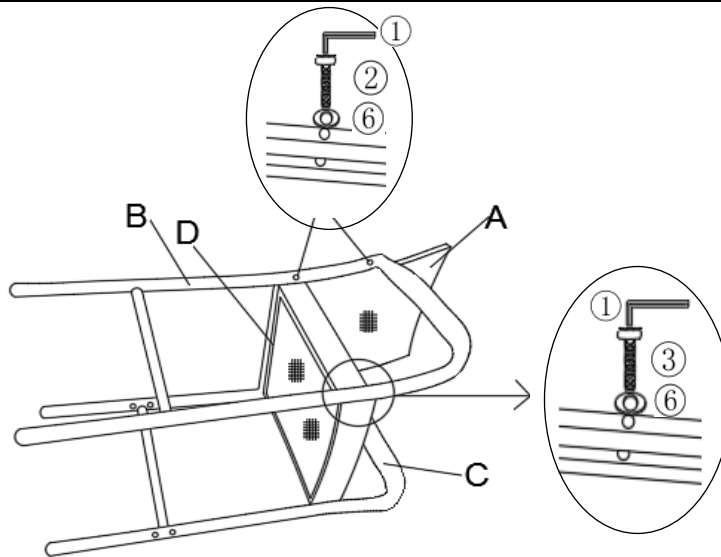

Turn the partially assembled chair 180°, to allow you to affix the other arm panel.
Repeat Steps 3 and 4 to assemble Left Armrest(B).
DO NOT FULLY TIGHTEN THE BOLTS.

Step 6

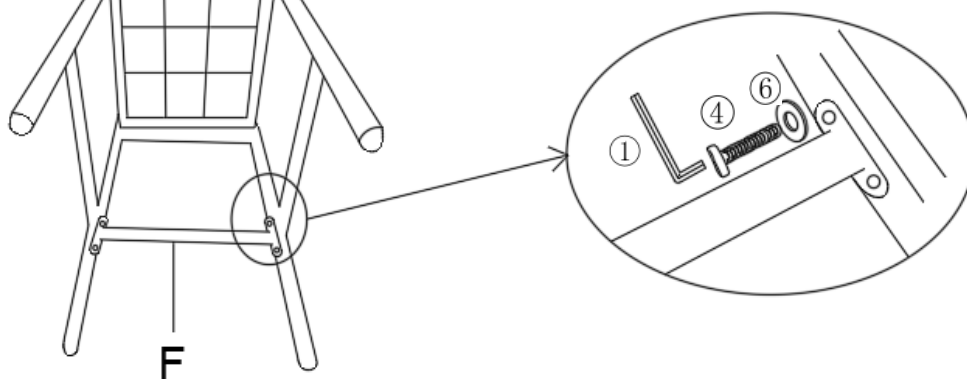

Attach the Back Foot Rest(F) between the back legs using Bolts(④) and Washers(⑥) with Allen Key(①).
DO NOT FULLY TIGHTEN THE BOLTS.

Step 7

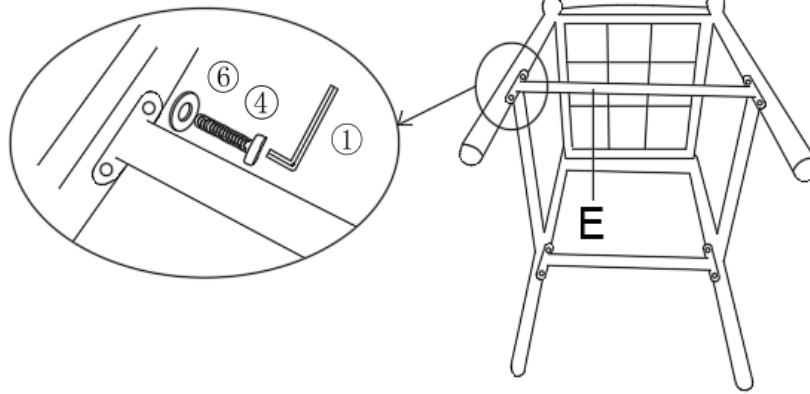

Attach the Front Foot Rest(E) between the front legs using Bolts(4) and Washers(6) with Allen Key(1).

DO NOT FULLY TIGHTEN THE BOLTS.

Step 8

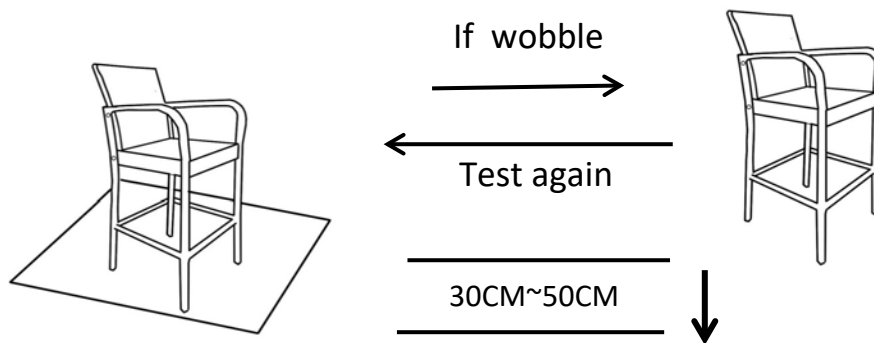

Place the barstool on a **LEVEL SURFACE** to check for wobbles.

If it wobbles lift the barstool to some 30cm to 50cm height from the ground.

Keep your feet and toes well away from the drop zone.

Drop the barstool freely and vertically with the four legs, hitting the ground, all at the same time.

This Drop Test will help to ensure that all the bolts and gaps are all in full alignment status.

Test again for evenness on a **LEVEL SURFACE**.

If no wobbles found, slowly and steadily turn the barstool upside down.

Then, proceed to tighten all bolts in a sequential manner.

CAUTION : When tightening these bolts, tighten sequentially.

DO NOT tighten any screw fully and then towards the next one.

This would cause the frame to warp.

If there is still wobbles, loosen the bolts and execute this same drop tests.

WARNING!! IF BARSTOOL IS NOT STABLE , IT COULD LEAD TO DAMAGING THE PRODUCT.

Step 9

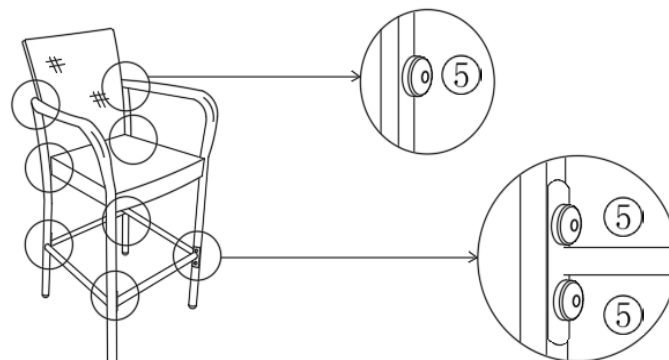





















Add the Bolt Caps(5) on the 12 Bolts as shown in the picture above.



Your Barstool is ready for use.

This Barstool can only be used on a flat and level surface.

Care & Maintenance

-   ● Do not put hot items directly on furniture surface
 -   ● Do not clean furniture with harsh cleansers or polish.
 -   ● To obtain the longest lifespan of your outdoor products, minimizing exposure to direct sunlight is recommended.
 -   ● Children should not climb or jump on the furniture.
 -   ● Do not write on furniture without a padded barrier to protect the surface.
 -   ● To obtain the longest lifespan of your outdoor products, avoid extended and lengthy exposure to rain, snow, and direct sunshine. Whenever possible cover the product and /or place under patio or awnings.
 -   ● Not for commercial use. For residential use only .
 -   ● Stains may be removed with mild soap solution and damp cloth.
 -   ● Keep away from sources of ignition.
-
-   ● Dust and pick-up spills using a clean, non-colored, lint-free cloth .