

Assembly Guide

Contents

English ————— 01-08

German ————— 09-16

French ————— 17-24

Components

01 (x1)



02 (x1)

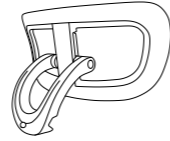

03 (x2)

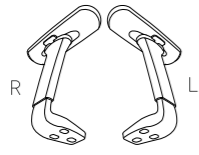

04 (x1)

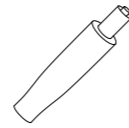

05 (x5)

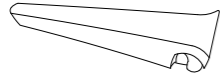

06 (x5)

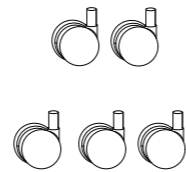

07 (x1)



A x2+1 M6X30MM



B x4+1 M6X35MM



C x6 M6X14X1.2MM



D x1



E x1

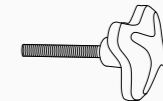

Installation

The installation steps are as follows:

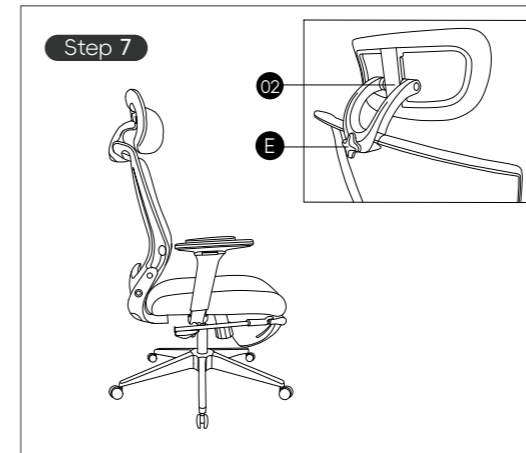
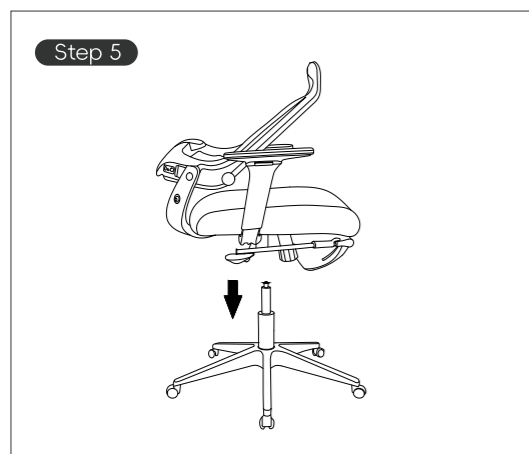
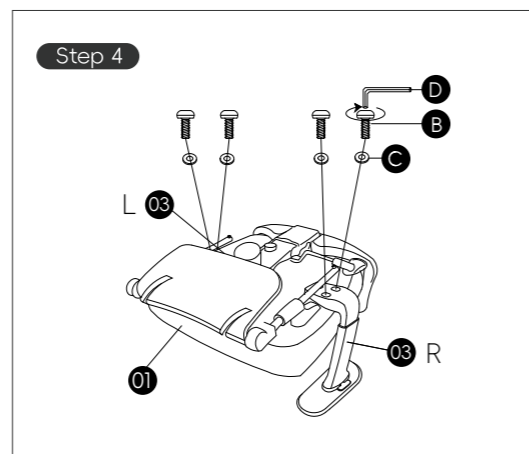
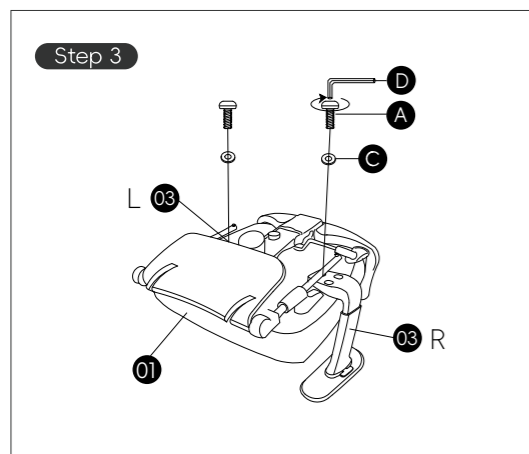
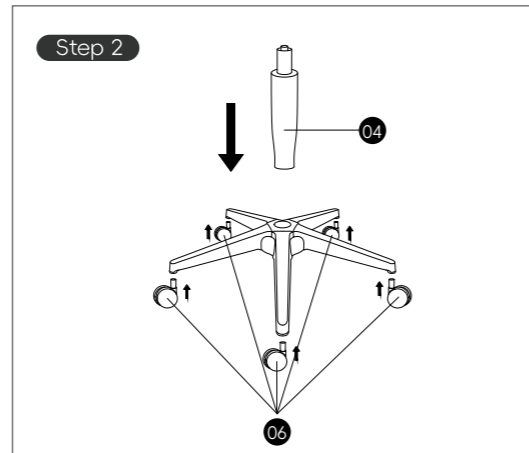
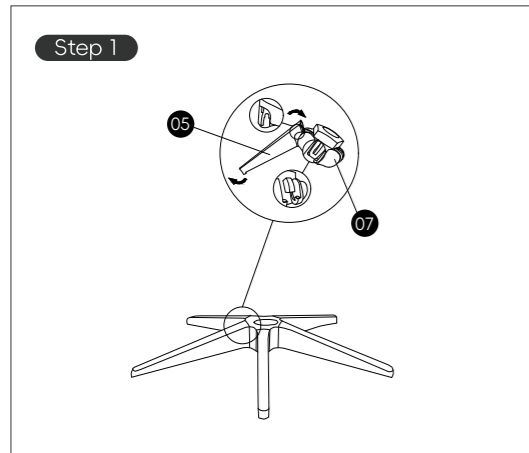

All Done!

Go ahead, try it out. You may experience what we call an "ahhh" sensation.

That's completely normal. You're now well equipped for whatever the workday throws at you.

Now, don't be shy. Show us how us how it looks!

User Guide

01

Headrest height and rotation adjustment.

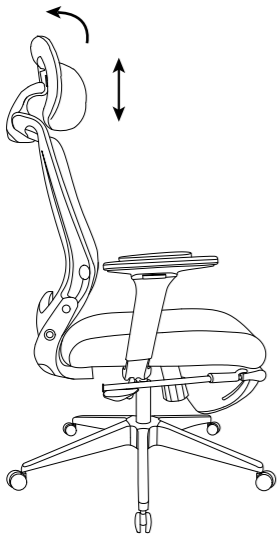

02

Pull the pedal forward, then turn it clockwise to open.

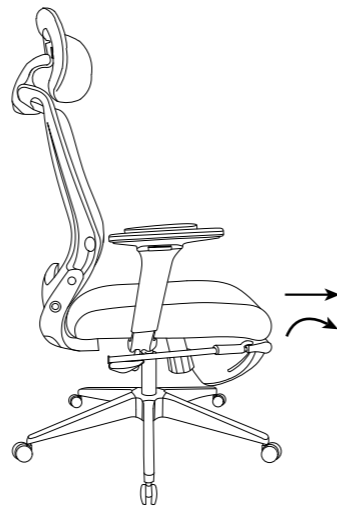

03

Push the pedal backward, then rotate it counterclockwise to retract.

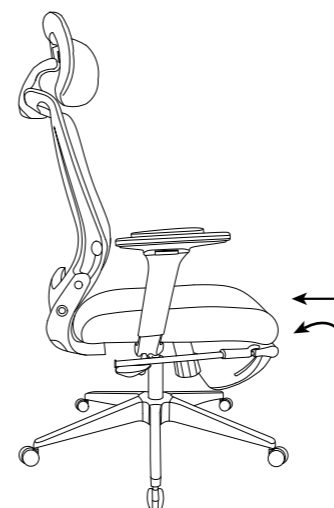

04

Standing behind the chair, press the button with both hands to fold the backrest.

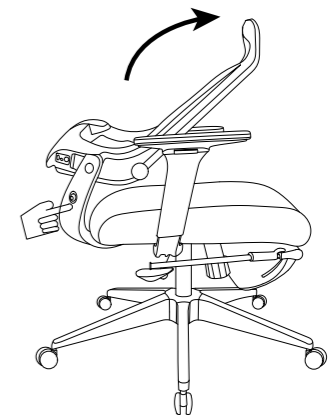

User Guide

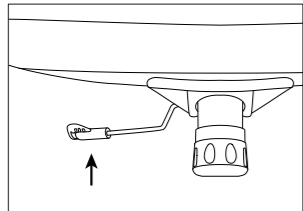

Pull the handle up to adjust the seat height.

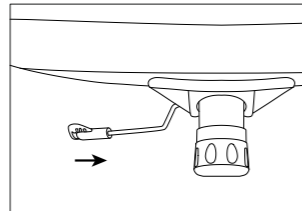

Push the handle to tilt the chair back and lock it.

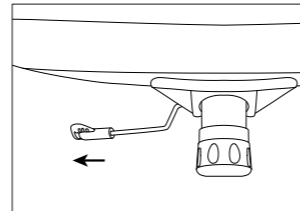

Pull out the handle to enable free recline.

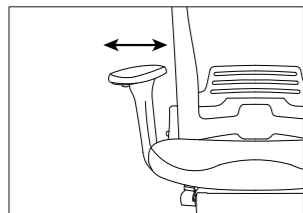

Armrest lateral adjustment.

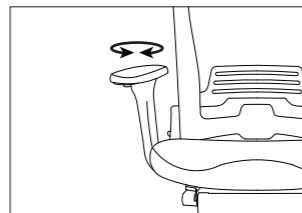

Armrest surface rotation adjustment.

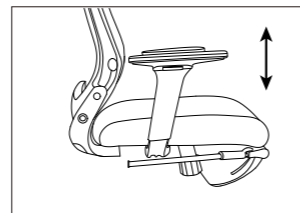

Armrest height adjustment.

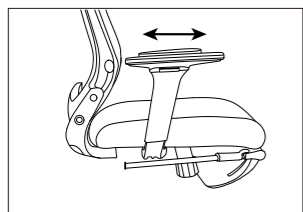

Forward and backward armrest adjustment.

Caution

- Use this product only for seating one person at a time.
- Some screws may be preassembled. If preassembled, ignore assembly instructions.
- Handle cylinders and mechanical components with care. They may contain grease that could stain chair surfaces or clothing if contacted.
- Do not use this chair as a step stool/ladder, or on uneven floor surfaces.
- Do not sit on any part of the chair except the seat.
- Do not use chair unless all bolts, screws, and knobs are tightened.
- Every six months, ensure all bolts, screws, and knobs are fully tightened to maintain stability.
- If any components are missing, damaged, deformed, or worn, discontinue use and repair only with manufacturer-authorized parts.
- Failure to follow these warnings could result in serious injury.

Komponenten

01 (x1)



02 (x1)

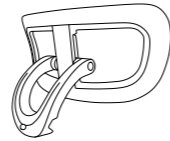

03 (x2)

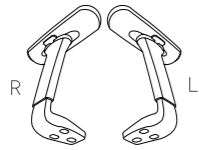

04 (x1)

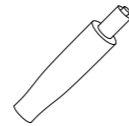

05 (x5)



06 (x5)

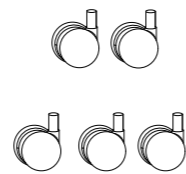

07 (x1)



A x2+1 M6X30MM



B x4+1 M6X35MM



C x6 M6X14X1.2MM



D x1



E x1

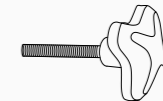

Montageanleitung

Die Montageanleitung läuft wie folgt ab:

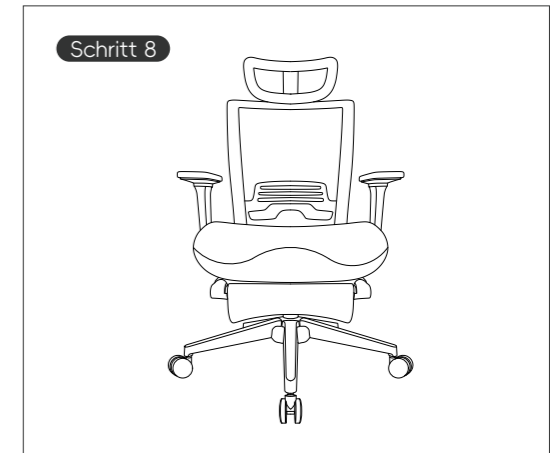
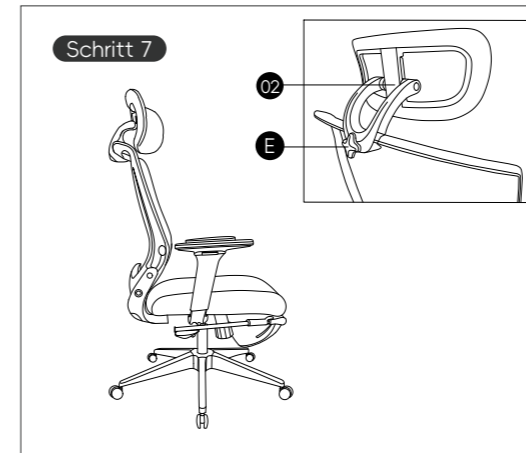
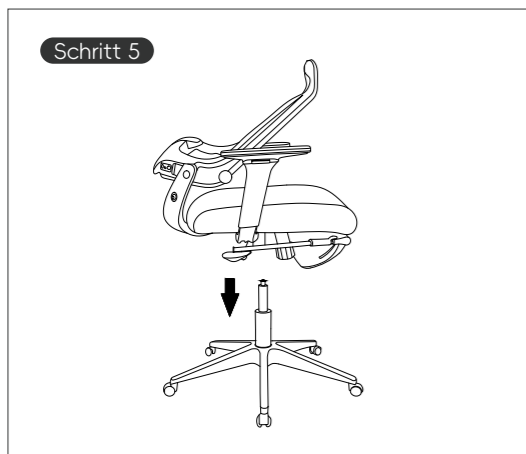
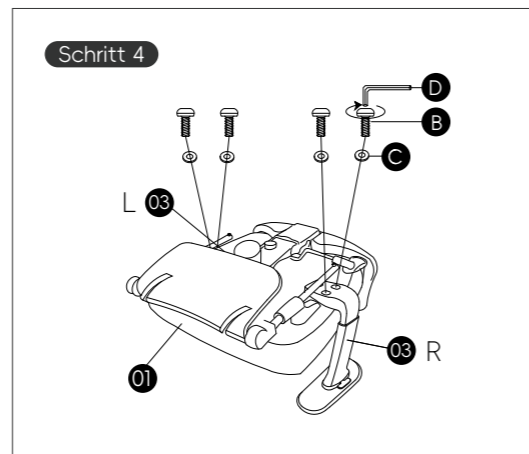
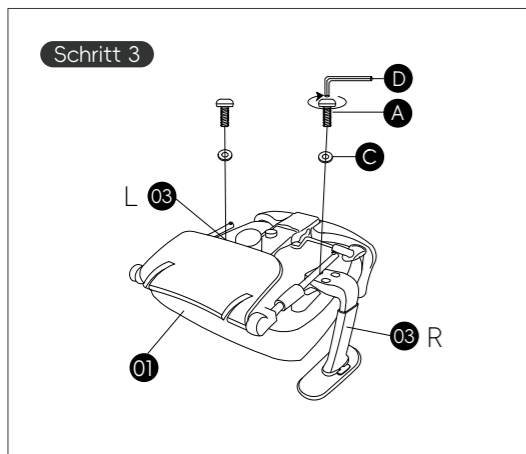
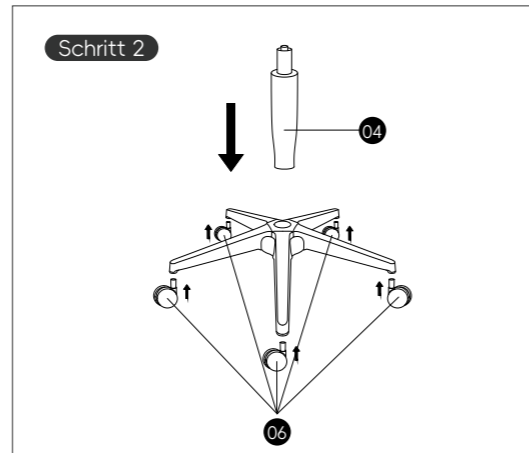
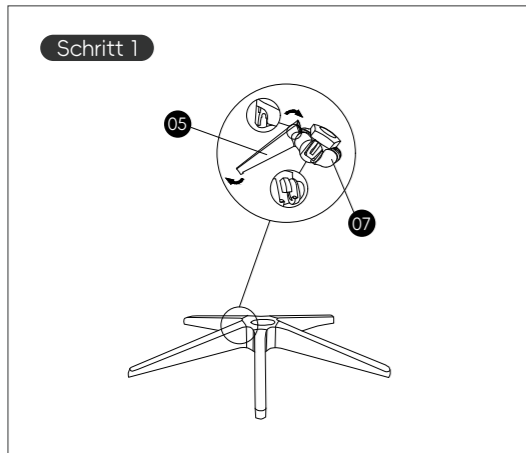

Geschafft!

Probieren Sie es aus, Sie werden vielleicht ein „ahhh“ - Gefühl verspüren.

Das ist völlig normal. Sie sind jetzt gut gerüstet für alles, was der Arbeitstag Ihnen abverlangt.

Seien Sie nicht schüchtern, lassen Sie uns sehen, wie es aussieht!

Benutzerhandbuch

01

Verstellung der Kopfstütze
in Höhe und Drehung.

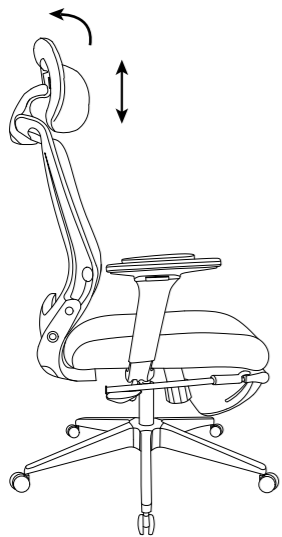

02

Ziehen Sie das Pedal nach vorne,
drehen Sie es dann im Uhrzeigersinn,
um es zu öffnen.

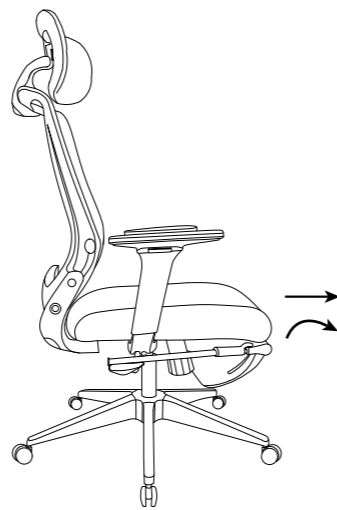

03

Pedal nach hinten schieben und
gegen den Uhrzeigersinn drehen,
um es einzuziehen.

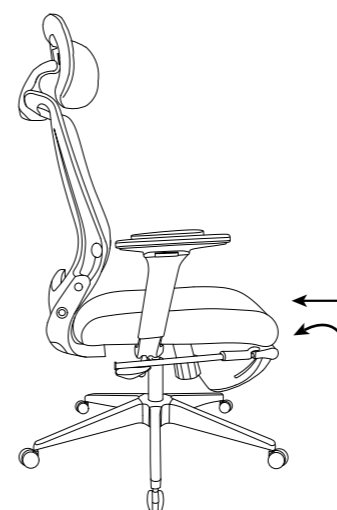

04

Hinter den Stuhl stellen, mit beiden
Händen den Knopf drücken, um die
Rückenlehne zu klappen.

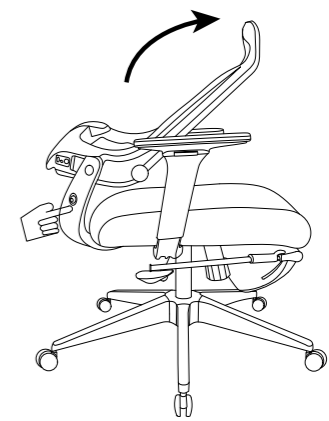

Benutzerhandbuch

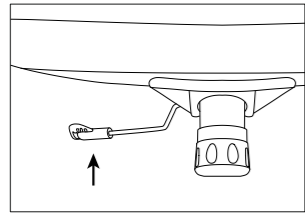

Ziehen Sie den Hebel nach oben, um die Sitzhöhe einzustellen.

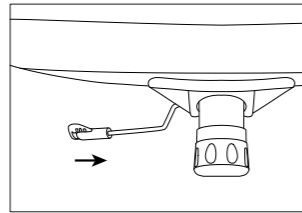

Drücken Sie den Hebel, um den Stuhl nach hinten zu neigen und zu arretieren.

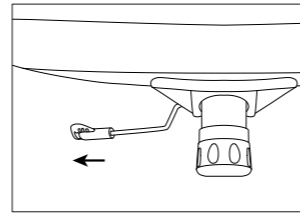

Ziehen Sie den Hebel heraus, um die freie Neigung zu aktivieren.

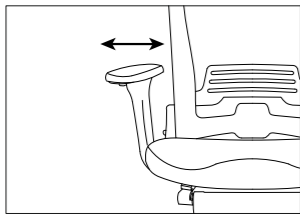

Seitliche Verstellung der Armlehnen.

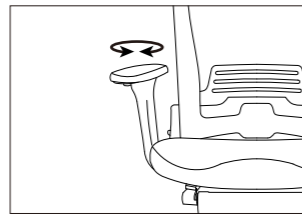

Einstellen der Drehung der Armlehne.

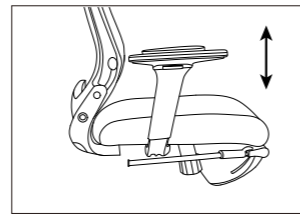

Höhenverstellung der Armlehnen.

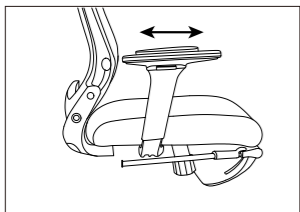

Vor- und Zurückverstellung der Armlehnen.

Achtung

- Verwenden Sie dieses Produkt nur für die Benutzung durch jeweils eine Person.
- Einige Schrauben können vormontiert sein. Wenn sie vormontiert sind, ignorieren Sie die Montageanleitung.
- Sie können Schmierfett enthalten, die bei Kontakt mit der Stuhloberfläche oder der Kleidung Flecken verursachen kann.
- Verwenden Sie den Stuhl nicht als Tritthocker/Leiter oder auf unebenen Böden.
- Setzen Sie sich auf keinen Teil des Stuhls außer auf den Sitz.
- Benutzen Sie den Stuhl nicht, wenn nicht alle Bolzen, Schrauben und Knöpfe fest angezogen sind.
- Stellen Sie alle sechs Monate sicher, dass alle Bolzen, Schrauben und Knöpfe fest angezogen sind, um die Stabilität zu gewährleisten.
- Wenn Teile fehlen, beschädigt, verformt oder abgenutzt sind, verwenden Sie den Stuhl nicht mehr und reparieren Sie ihn nur mit vom Hersteller zugelassenen Teilen.
- Die Nichtbeachtung dieser Warnhinweise kann zu schweren Verletzungen führen.

Composants

01 (x1)



02 (x1)

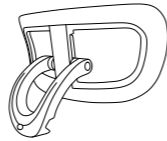

03 (x2)

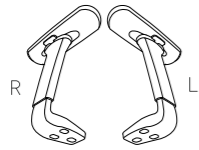

04 (x1)

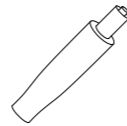

05 (x5)

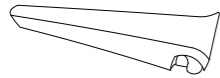

06 (x5)

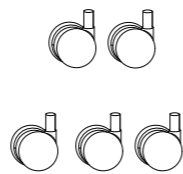

07 (x1)



A x2+1 M6X30MM



B x4+1 M6X35MM



C x6 M6X14X1.2MM



D x1



E x1

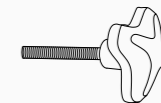

Installation

Les étapes d'installation sont les suivantes :

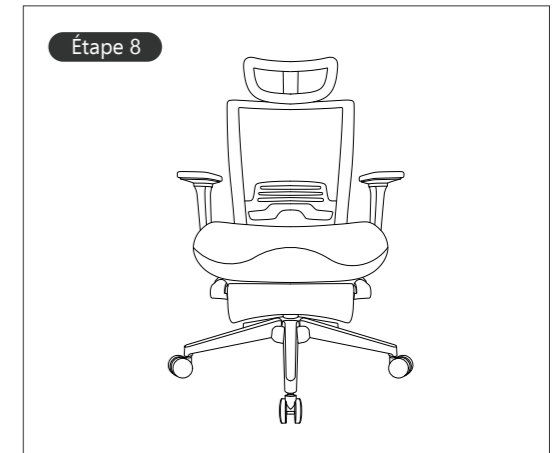
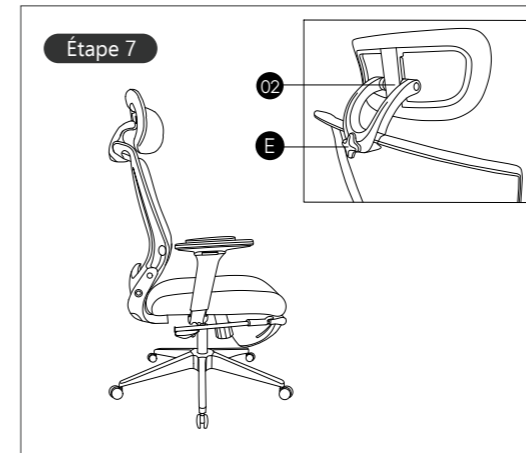
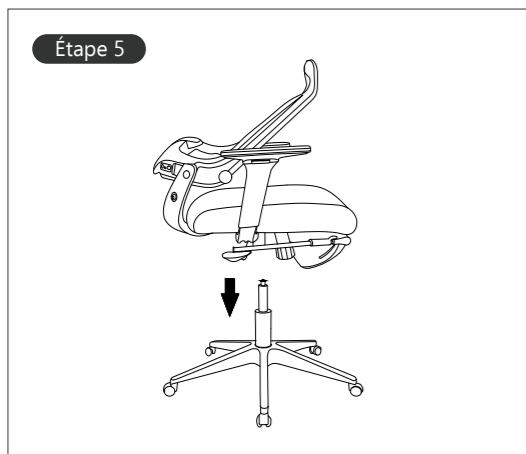
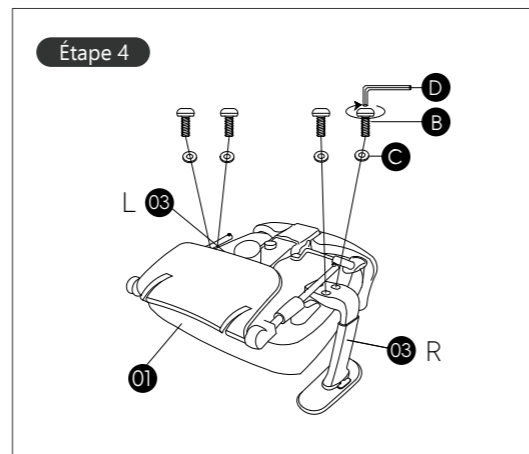
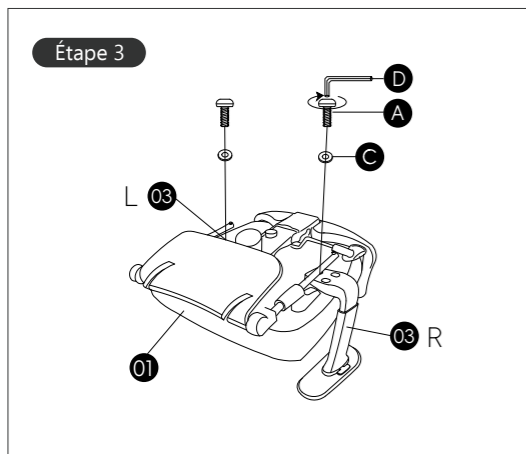
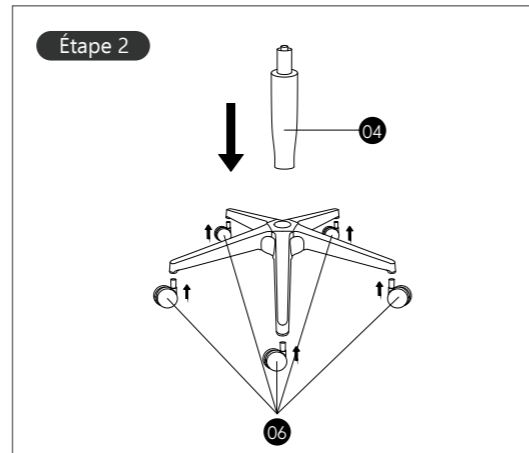
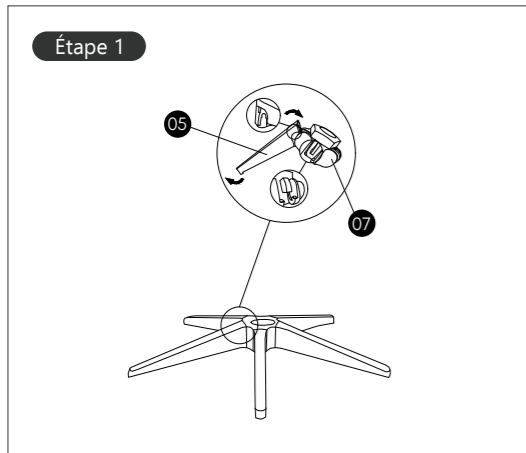

C'est terminé!

Allez-y, essayez-le. Vous pourriez ressentir ce que nous appelons une sensation d'"ahhh".

C'est tout à fait normal. Vous êtes maintenant parfaitement équipé pour affronter n'importe quoi que la journée de travail puisse vous proposer.

Maintenant, n'ayez pas peur. Montrez-nous comment ça Looks !

Guide d'utilisation

01

Réglage de la hauteur et de la rotation de l'appui-tête.

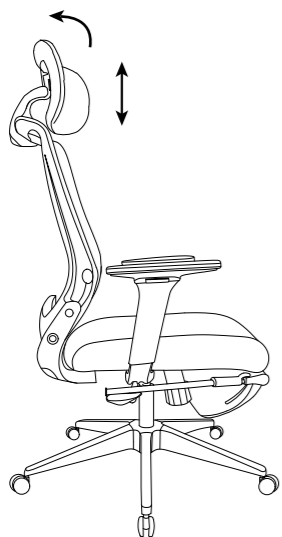

02

Tirez la pédale vers l'avant, puis tournez-la dans le sens des aiguilles d'une montre pour l'ouvrir.

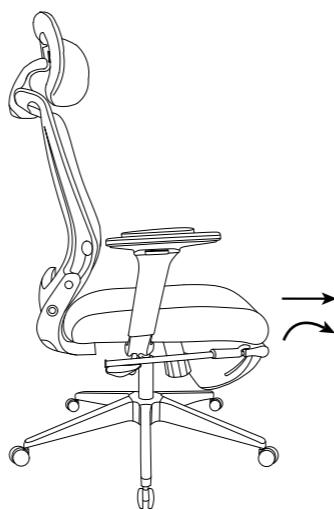

03

Poussez la pédale vers l'arrière, puis tournez-la dans le sens antihoraire pour la rétracter.

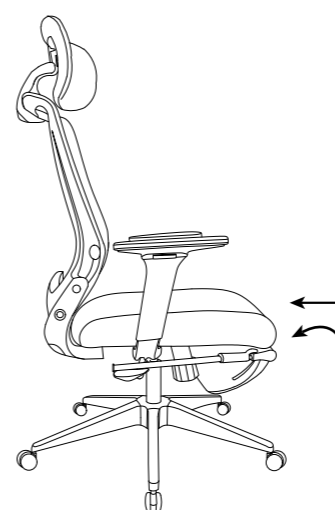

04

Derrière la chaise, appuyez à deux mains sur le bouton pour rabattre le dossier.

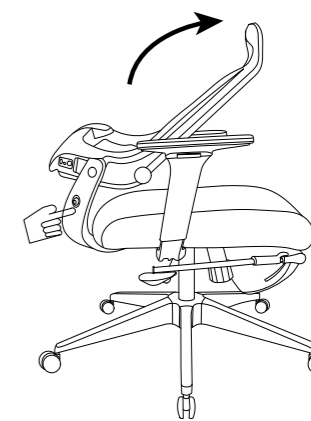

Guide d'utilisation

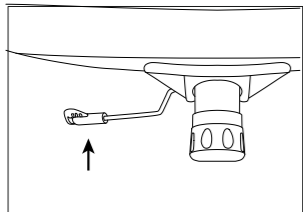

Tirez la poignée vers le haut pour régler la hauteur du siège.

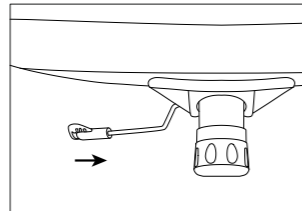

Appuyez sur la poignée pour incliner le fauteuil vers l'arrière et le verrouiller.

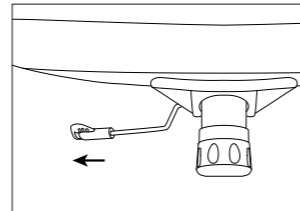

Tirez la poignée pour activer l'inclinaison libre.

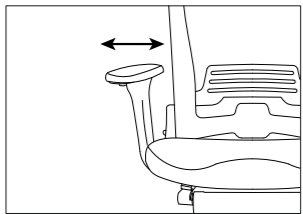

Réglage latéral des accoudoirs.

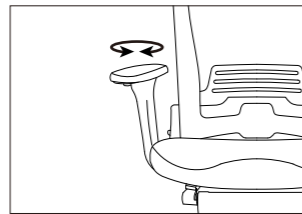

Réglage de la rotation de la surface des accoudoirs.

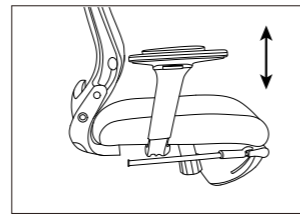

Réglage en hauteur des accoudoirs.

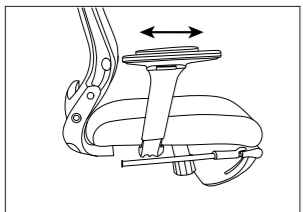

Réglage avant-arrière des accoudoirs.

Avertissement

- Ce produit ne peut être utilisé que pour asseoir une seule personne à la fois.
- Certains vis peuvent être préassemblés. En cas de préassemblage, ignorez les instructions d'assemblage.
- Manipulez avec soin les cylindres et les composants mécaniques. Ils peuvent contenir de la graisse qui pourrait tacher les surfaces de la chaise ou le vêtement en cas de contact.
- Ne pas utiliser cette chaise en tant que tabouret/échelle, ou sur des surfaces de sol inégales.
- Ne pas s'asseoir sur toute partie de la chaise autre que le siège.
- Ne pas utiliser la chaise si tous les boulons, vis et boutons ne sont pas serrés.
- Tous les six mois, assurez-vous que tous les boulons, vis et boutons sont entièrement serrés pour maintenir la stabilité.
- Si des composants manquent, sont endommagés, déformés ou usés, arrêtez l'utilisation et ne les réparez que avec des pièces autorisées par le fabricant.
- Le non-respect de ces avertissements pourrait entraîner de graves blessures.