











# ASSEMBLY INSTRUCTIONS

Don't tighten any Bolts until all Bolts on a step have been started

Thank you for purchasing this quality product. Be sure to check all packing material carefully for small parts, which may have come loose inside the carton during shipment. Identify and count all parts and compare with the HARDWARE LIST below.

| NO. | PARTS LIST                                                                        |                     | PARTS NO.                  | Q'TY     |
|-----|-----------------------------------------------------------------------------------|---------------------|----------------------------|----------|
| A   |  | Bonded leather seat | B2208-26LP1                | 1        |
|     |                                                                                   | Top ring            | B2208-26LP2                | pre-assy |
| B   |  | Metal swivel        | B2200-26LP3                | 1        |
|     |                                                                                   | Middle ring         | B2208-26LP4                | pre-assy |
| C   |  | Bottom ring         | B2208-26LP5                | 1        |
| D   |  | Stool leg           | B2208-26LP6<br>B2208-30LP6 | 4        |
| E   |  | Stool back          | B2208-26LP8                | 1        |

| NO. | PARTS LIST                                                                         |              | PARTS NO.   | Q'TY |
|-----|------------------------------------------------------------------------------------|--------------|-------------|------|
| 1   |  | 1/4"*2"      | B2208-26LP7 | 8    |
| 2   |  | 1/4"*1-1/2"  |             | 4    |
| 3   |  | 1/4"*1"      |             | 8    |
| 4   |  | 1/4"         |             | 20   |
| 5   |  | 1/4"*19mm    |             | 20   |
| 6   |  | Allen wrench |             | 1    |

## STEP 1

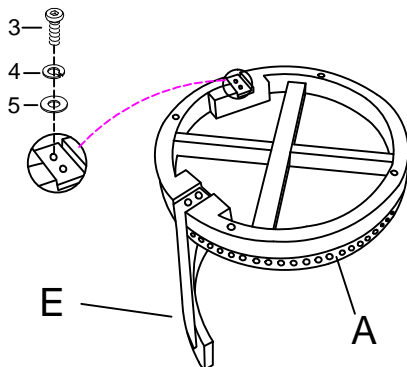

1. Attach the Stool Back (E) to the (A), using Bolts (3+4+5) to tighten, as shown.

## STEP 2

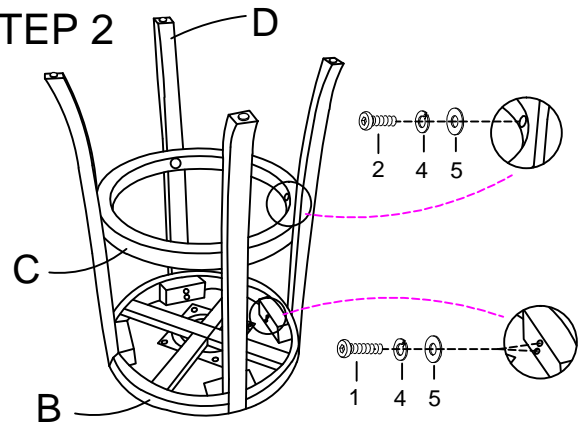

1. Attach the four legs (D) to the Middle ring (B), using Bolts (1+4+5) to tighten, as shown.  
2. Attach the Bottom ring (C) to the Legs, using Bolts (2+4+5) to tighten, as shown.

## STEP 3

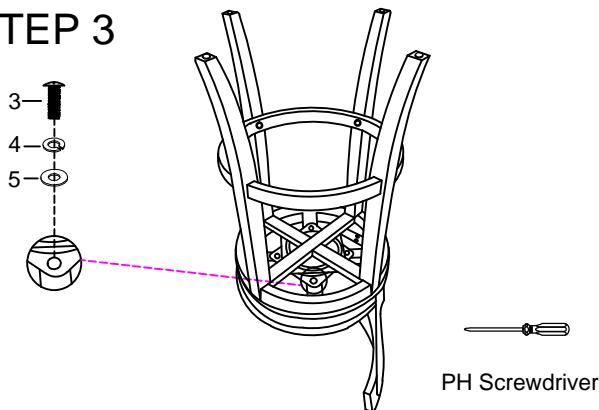

1. Upside down the Wooden Seat Back (STEP 1) and put it on a smooth and stable working stand.  
2. Attach the Stool Base (STEP 2) to the Seat w/pre-assembly Seat Back (STEP 1), using a PH screwdriver (not included) and Bolts (3+4+5) to tighten, as shown.

## STEP 4

1. It is complete for using.



Caution: 1: All bolts must be tightened mandatorily in easy step.  
2: It is also mandatorily recommended to periodically check bolts and retighten as needed.