

HOME SOURCE®

ASSEMBLY INSTRUCTION

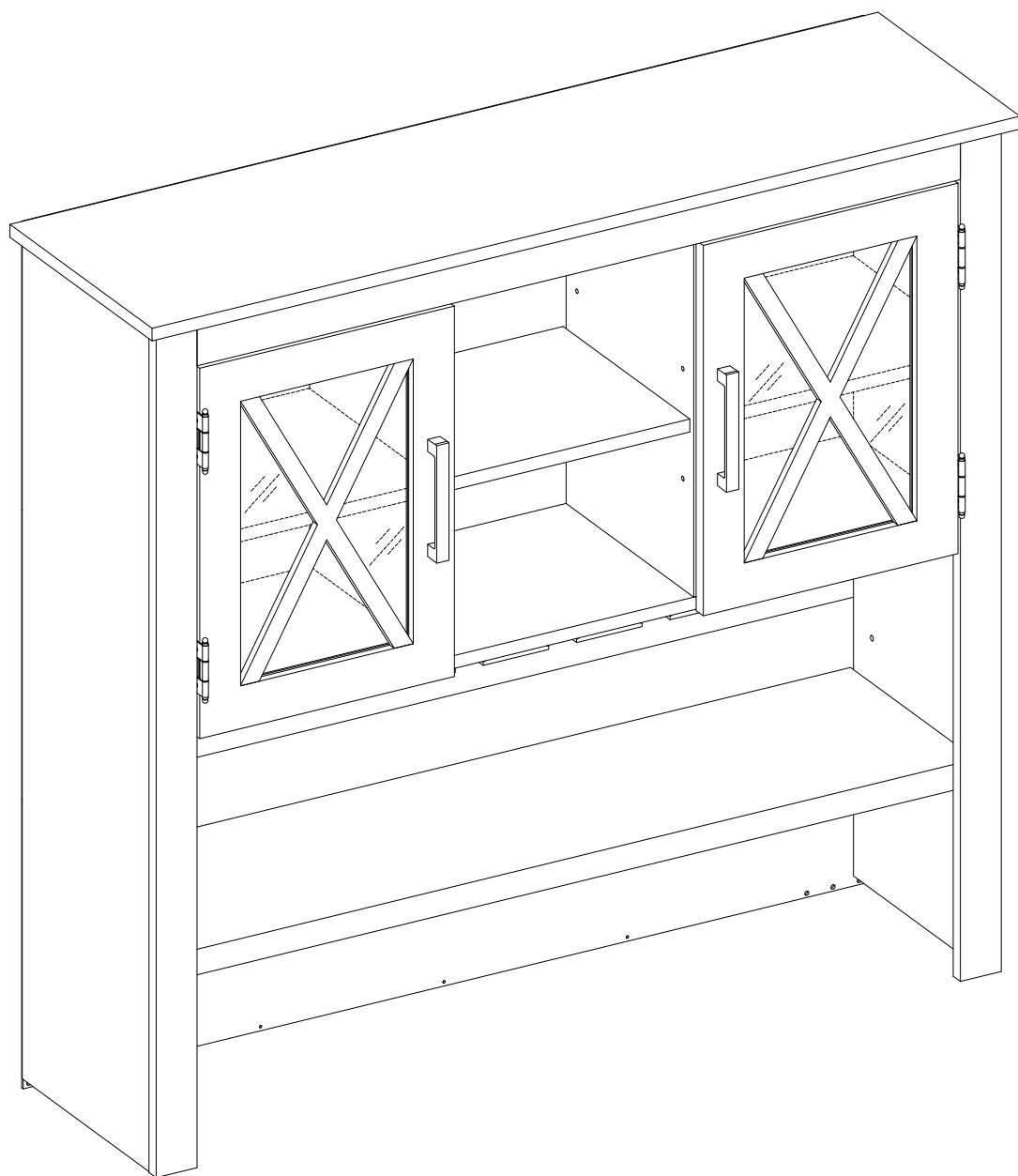





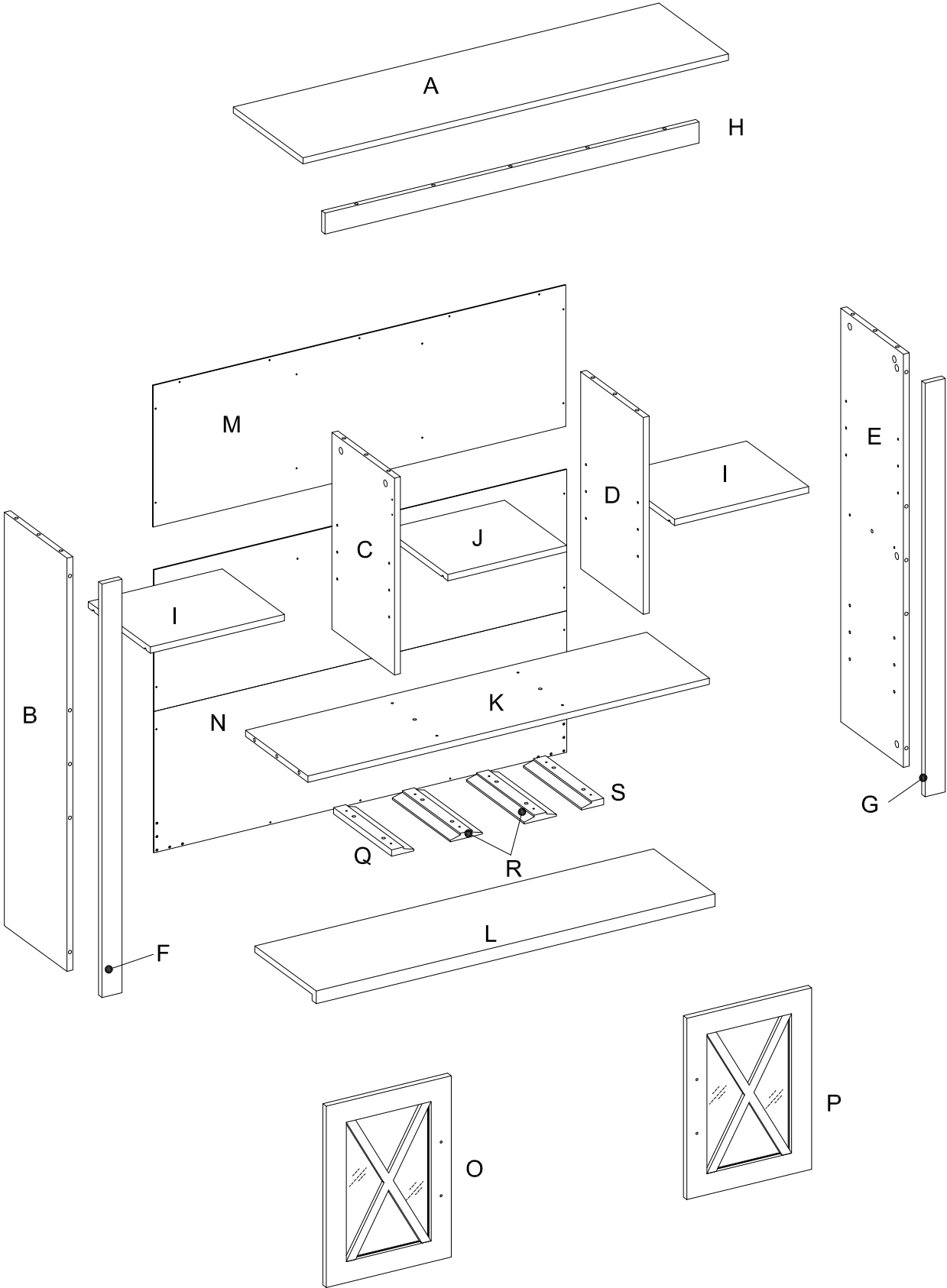







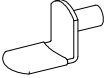





MODEL: JZ66-TOP

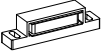

Parts List

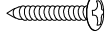

Hardware List

1		Ø6x35mm	Cam bolt	21 pcs
2		Ø8x30mm	Wood dowel	14 pcs
3		Ø15x11mm	Cam lock	21 pcs
4		Ø8x20mm	Wood dowel	8 pcs
5		Ø4x25mm	Fast screw	8 pcs
6			Shelf pin	4 pcs
7		Ø3.5x12mm	Screw	16 pcs
8			Handle	2 pcs
9		Ø4x22mm	Handle bolt	4 pcs
10			Door hinge	4 pcs
11		Ø3x12mm	Screw	2 pcs
12			Support pin	12 pcs
13			Screw	29 pcs
14		Ø4x44mm	Fast screw	4 pcs
15			Magnetic piece	2 pcs
16			Magnetic catch	2 pcs
17			Glue	1 pcs
18		Ø3x15mm	Screw	4 pcs
19			Metal bracket	2 pcs
20		Ø4x19mm	Screw	10 pcs
21		Tipping Restraint Hardware (Inside Plastic White Bag)		2 pcs

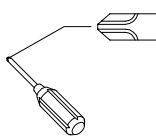

Philips head screwdriver required for assembly
(not included)

BEFORE THE ASSEMBLY

Note: Top should be used together with the Base. Top can not be used seperately.

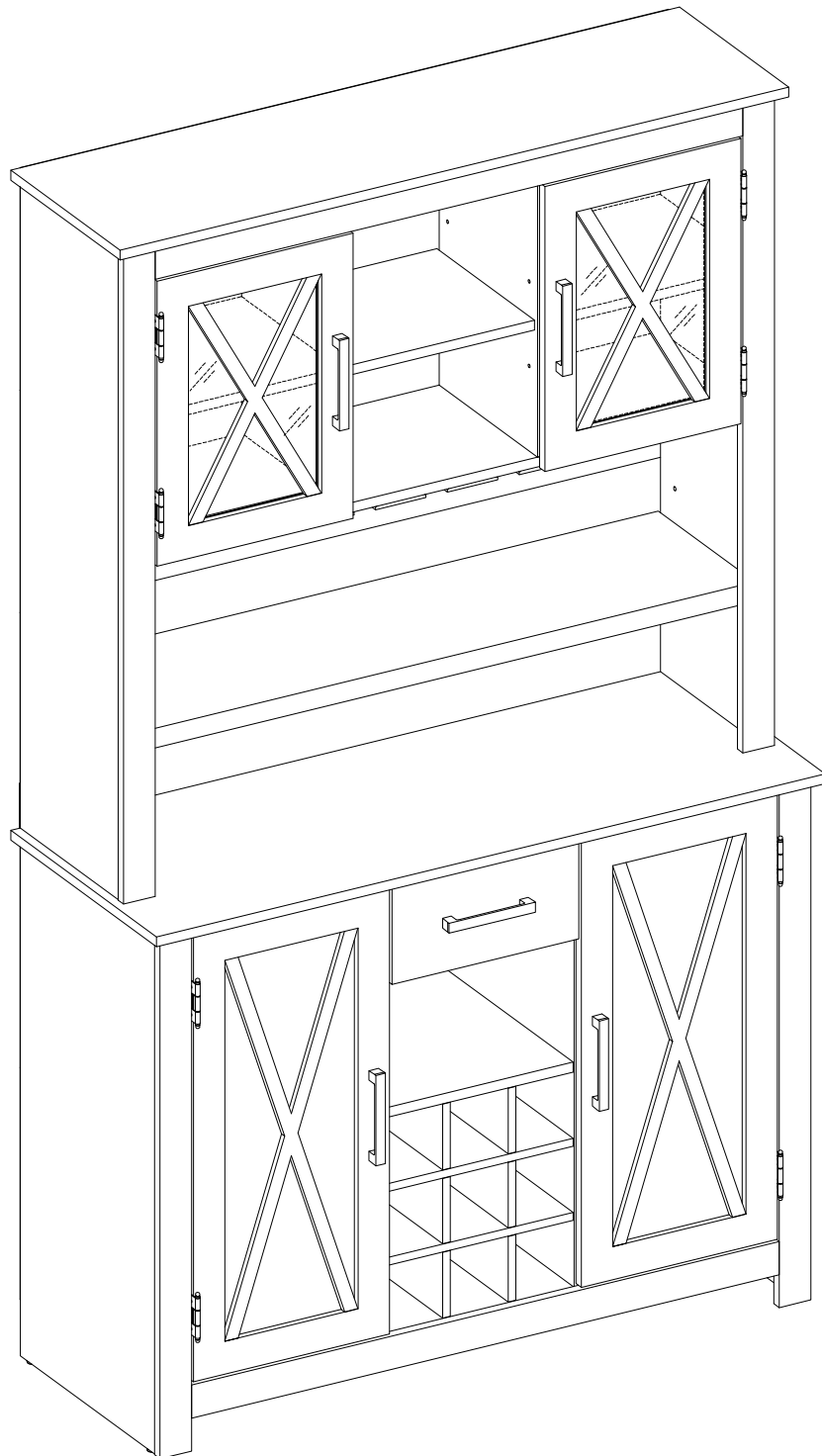

Step 1

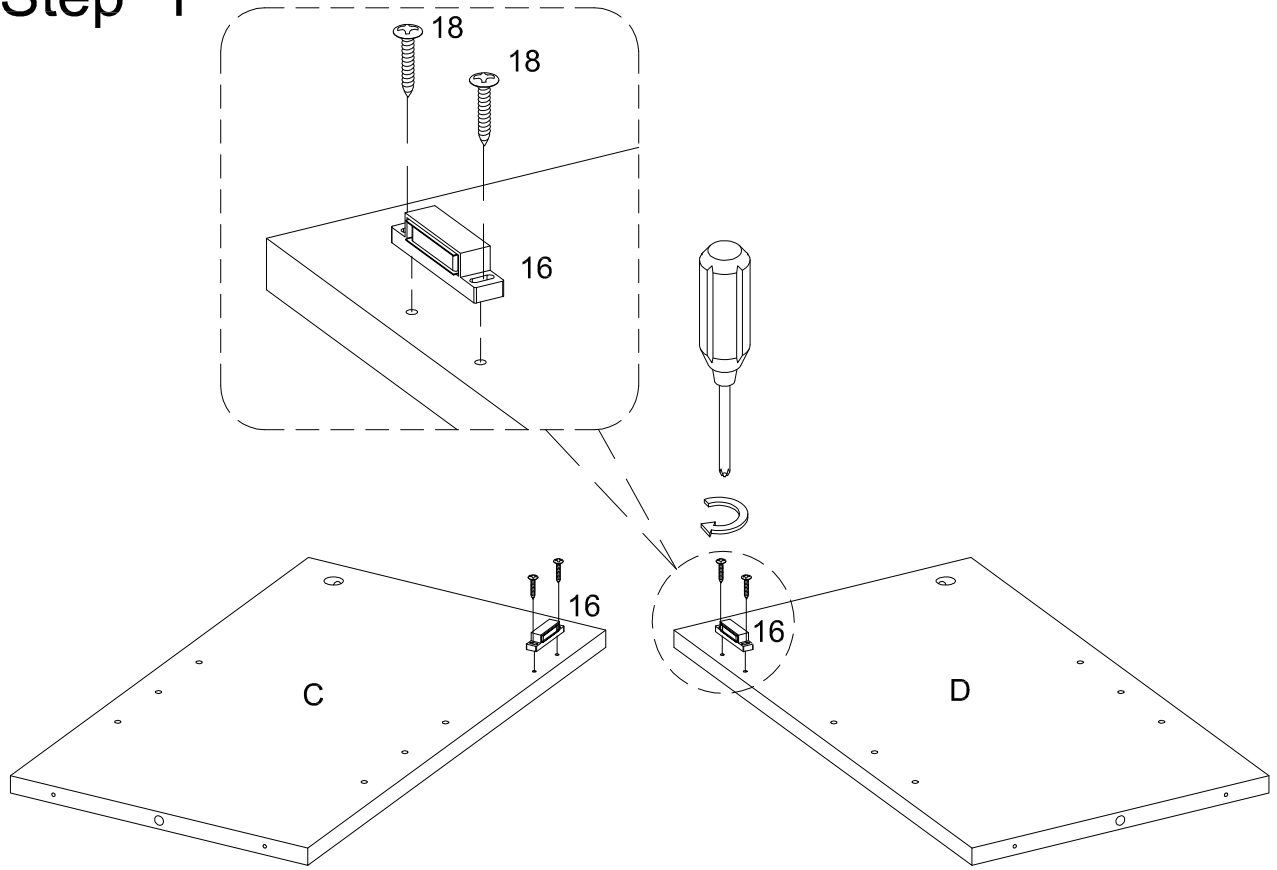

Step 2

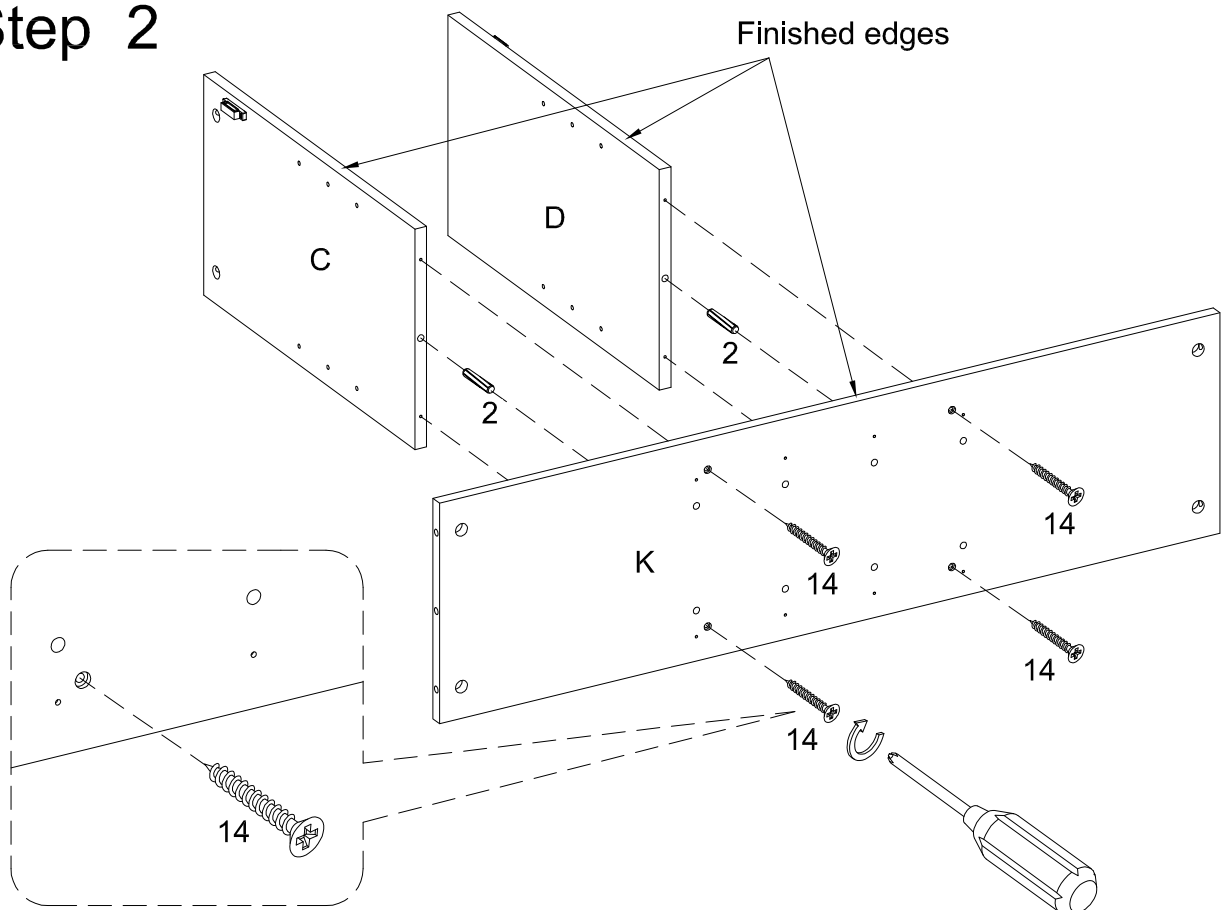

Step 3

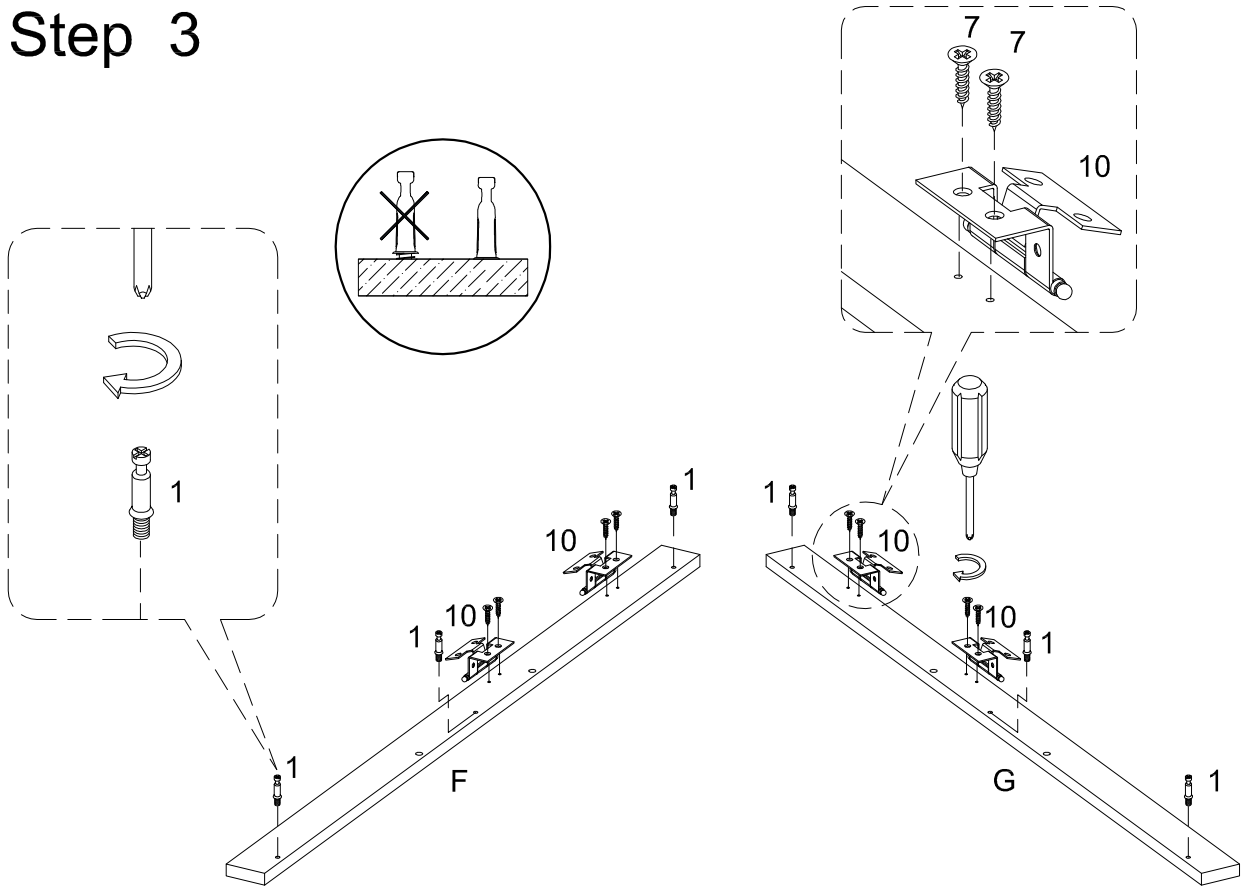

Step 4

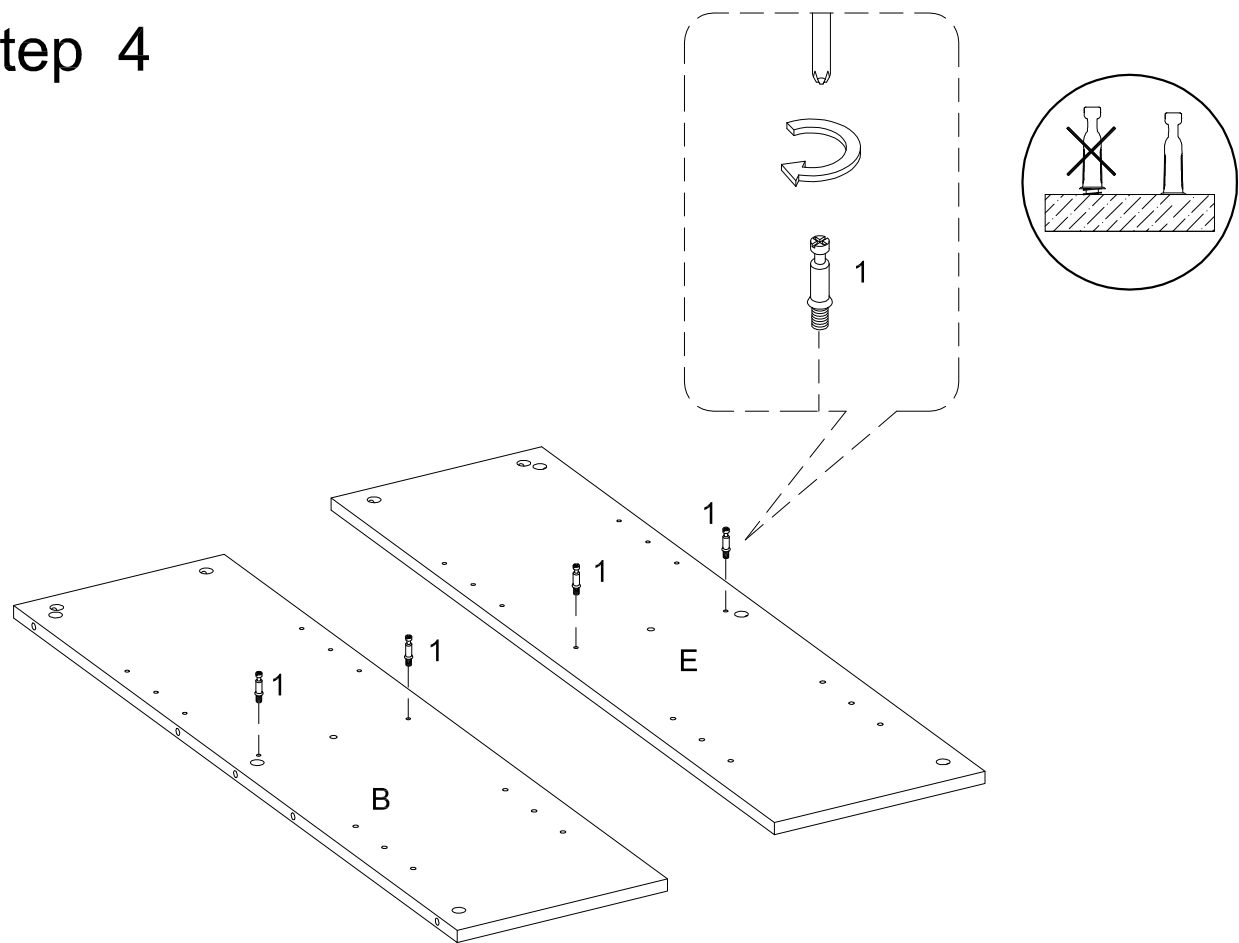

Step 5

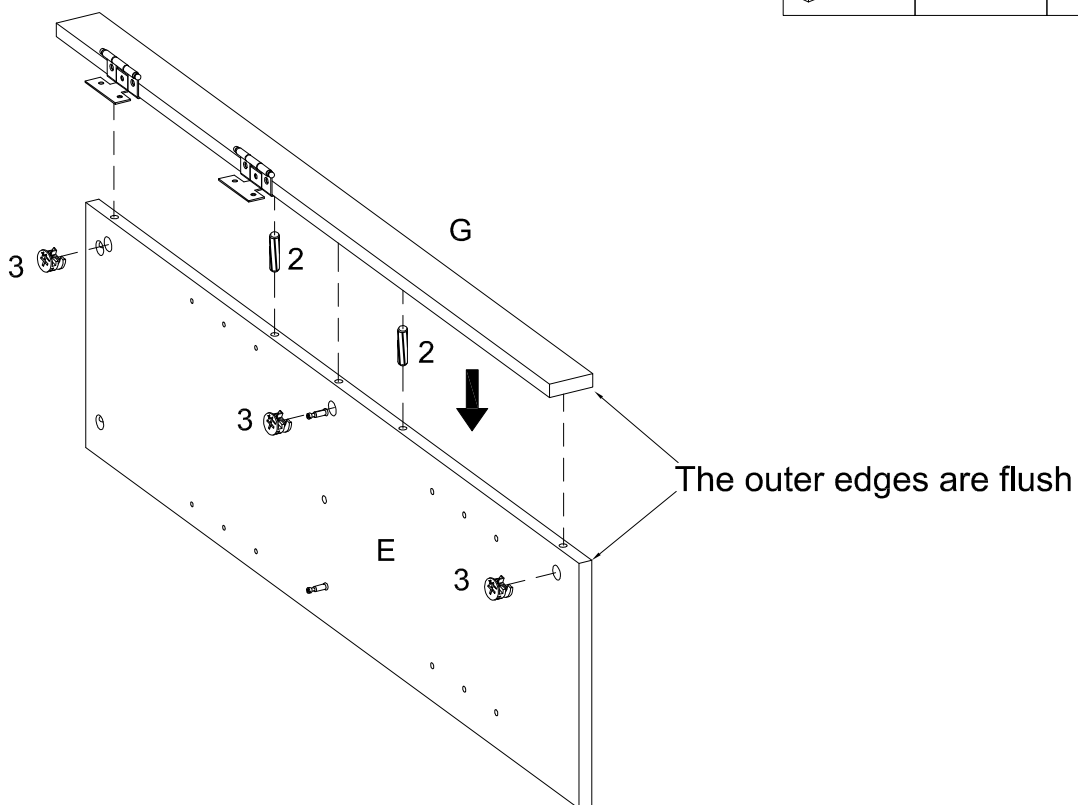
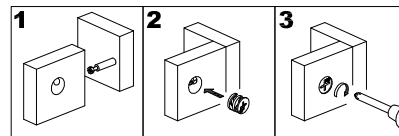

Step 6

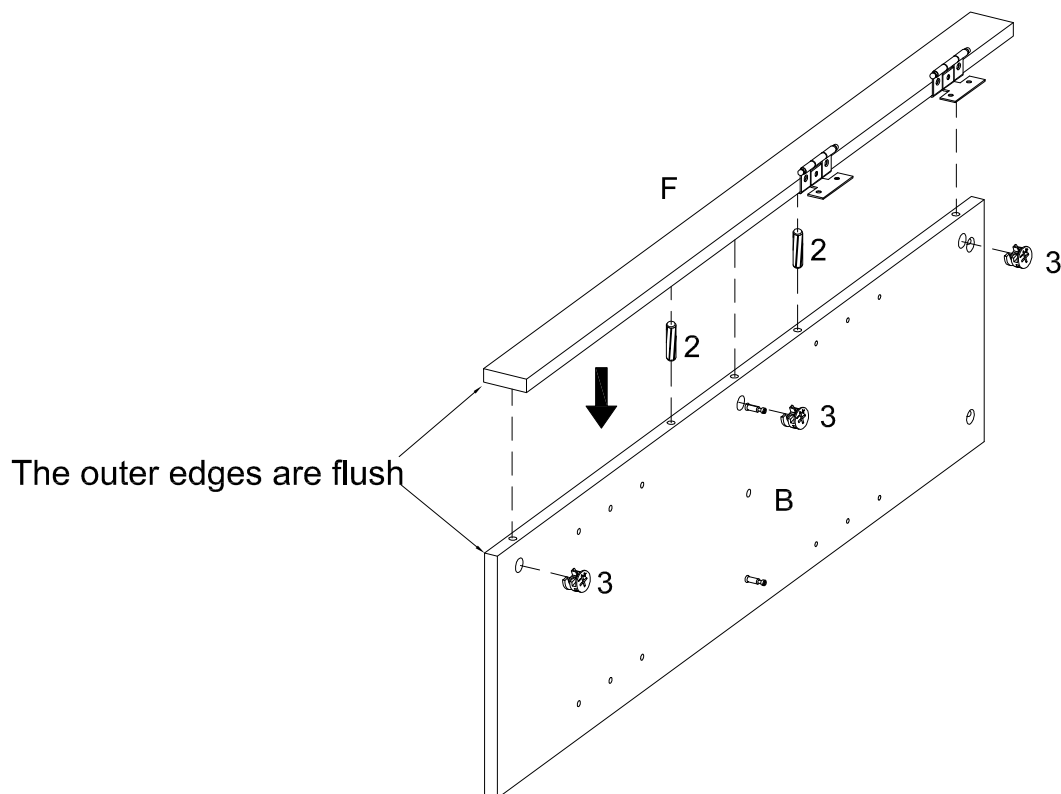
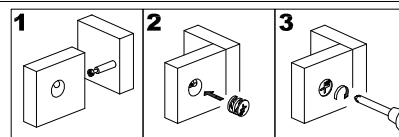

Step 7

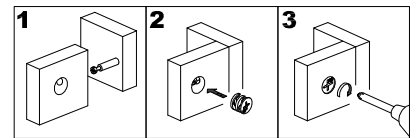

Finished edges

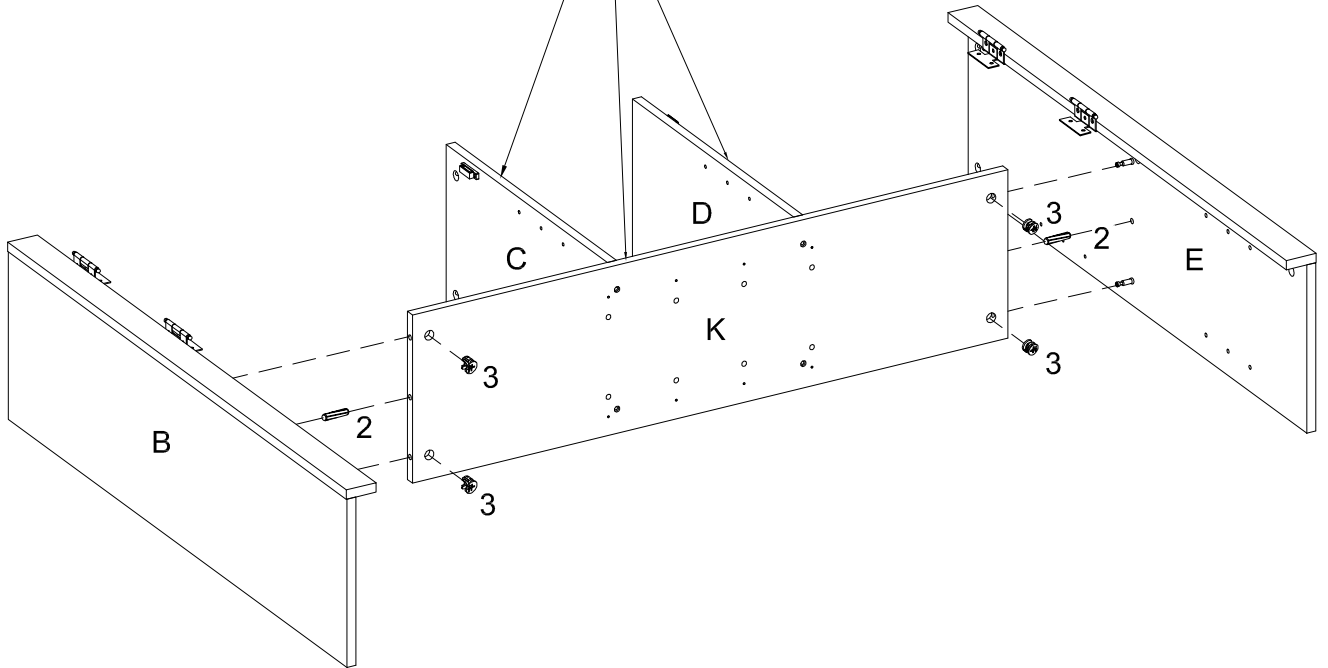

Step 8

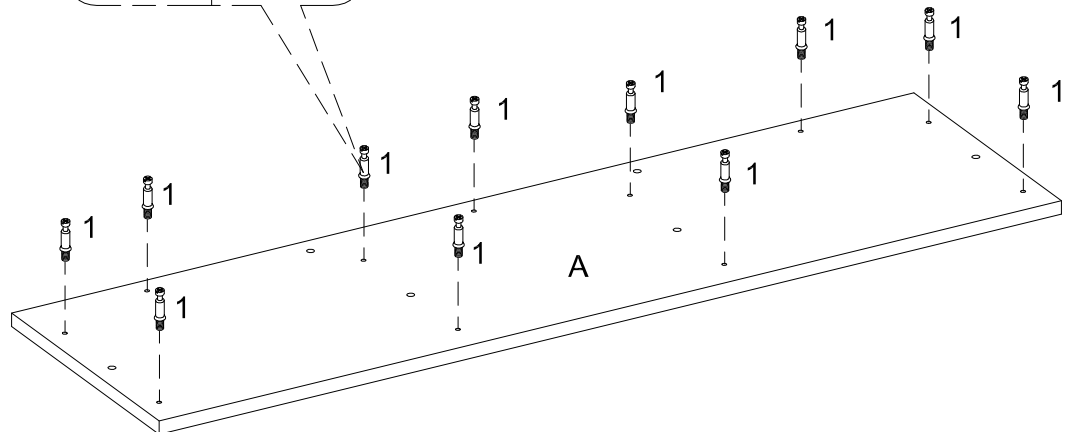
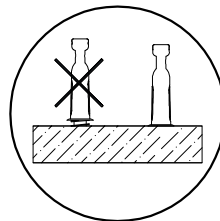
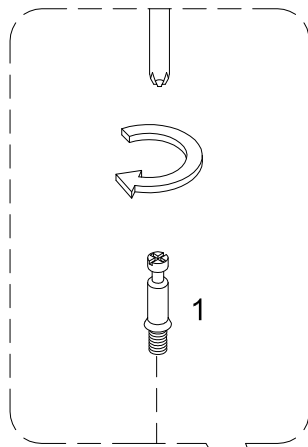

Step 9

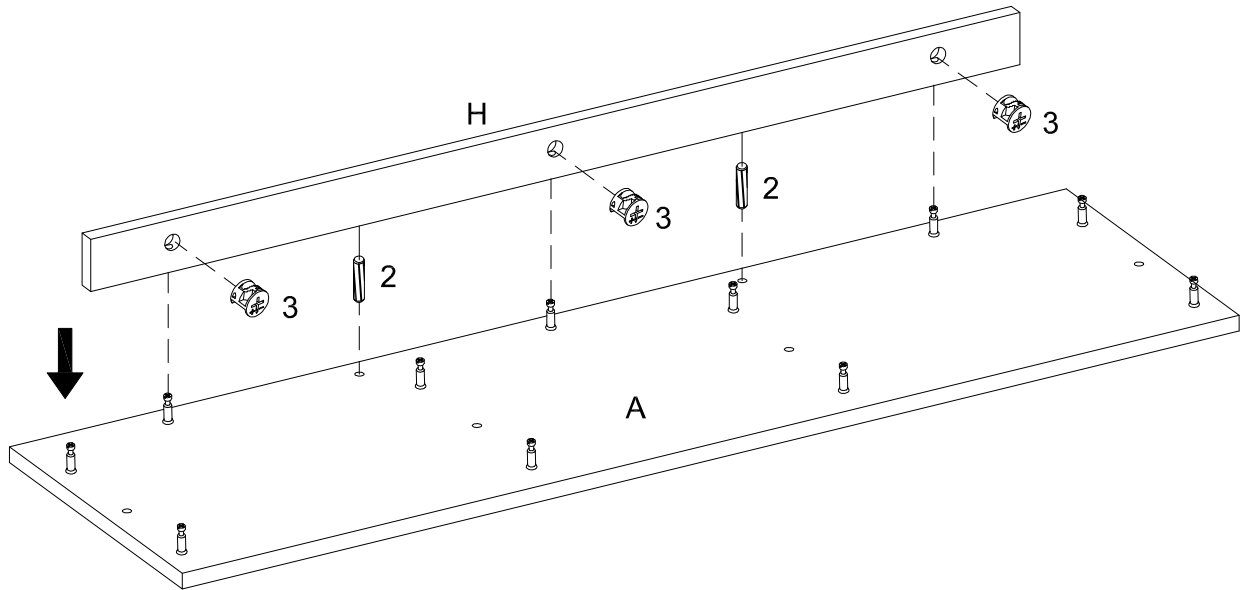
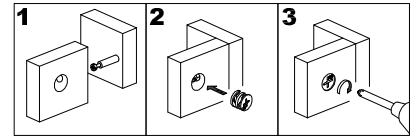

Step 10

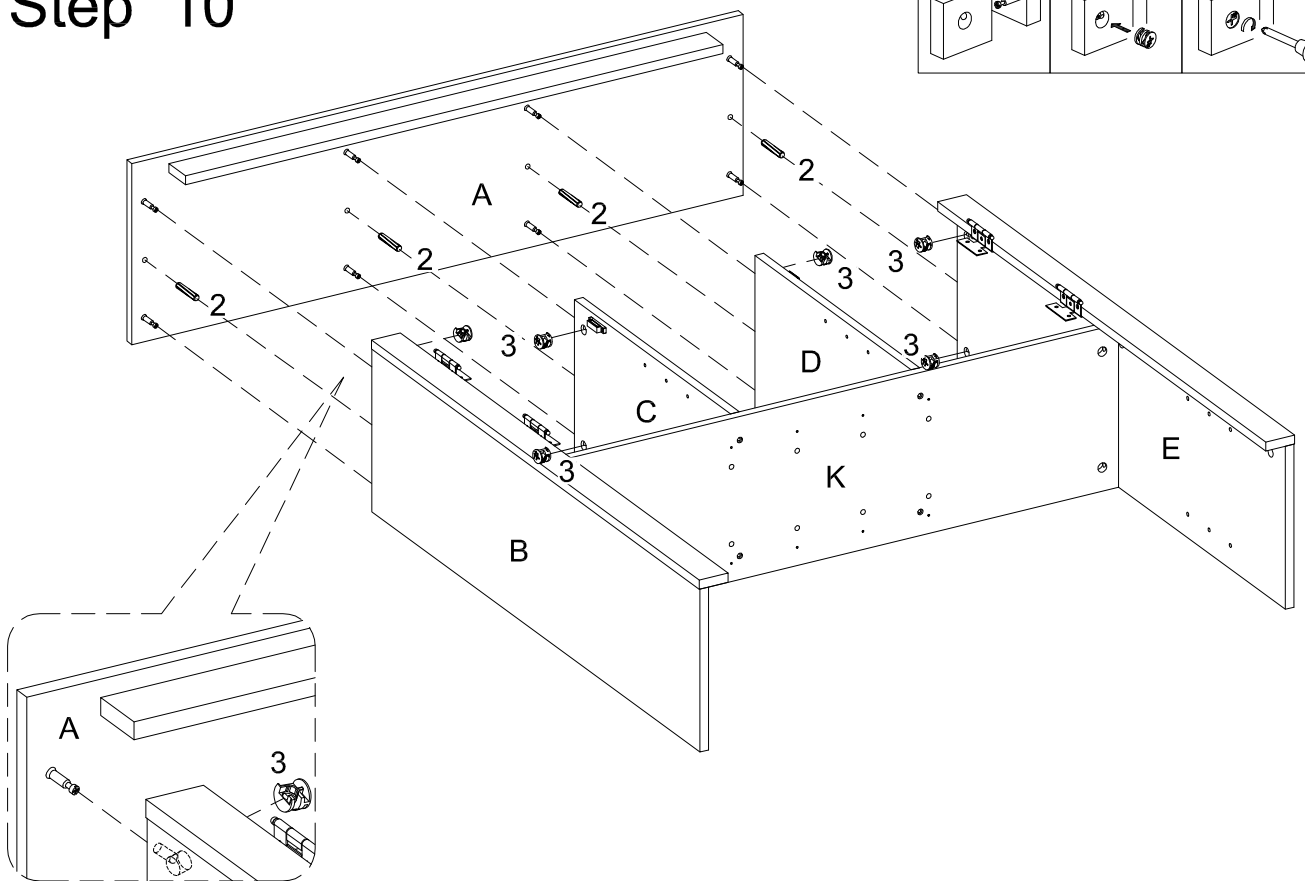
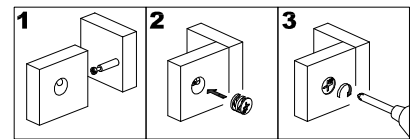

Step 13

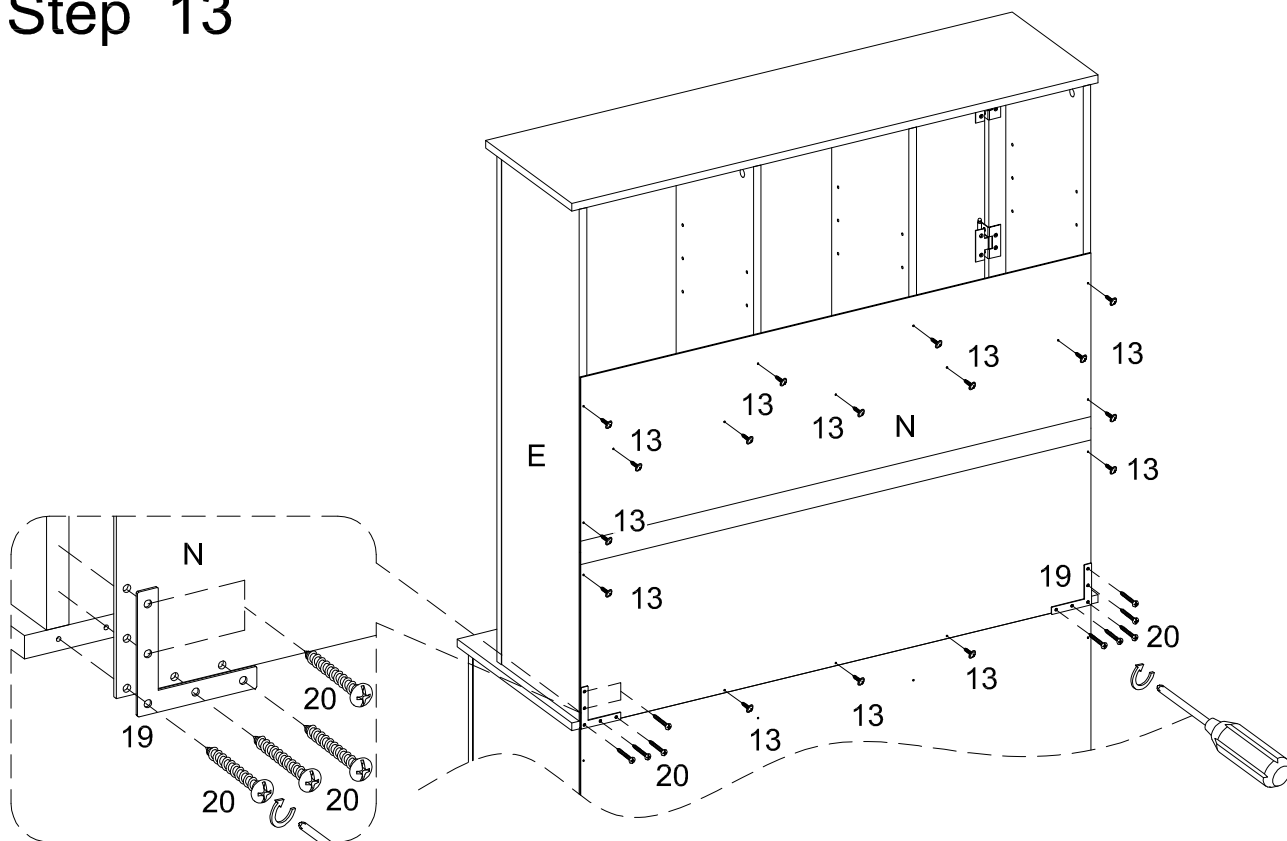

Step 14

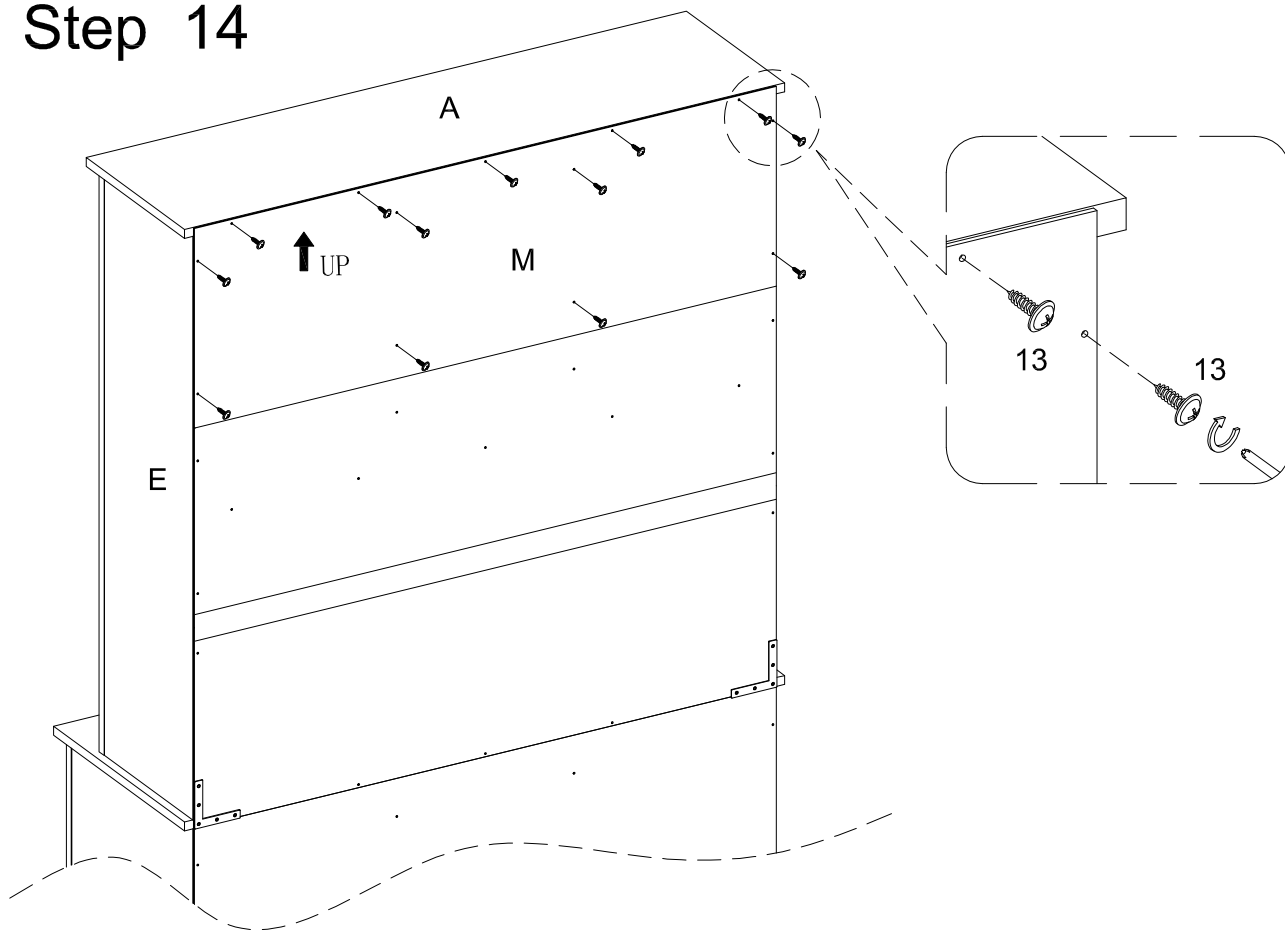

Step 15

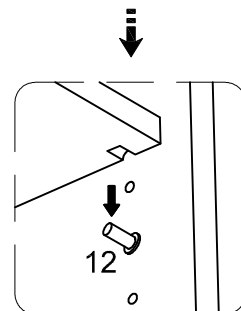
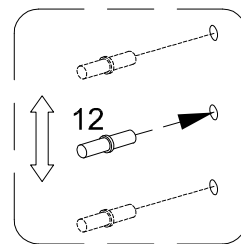
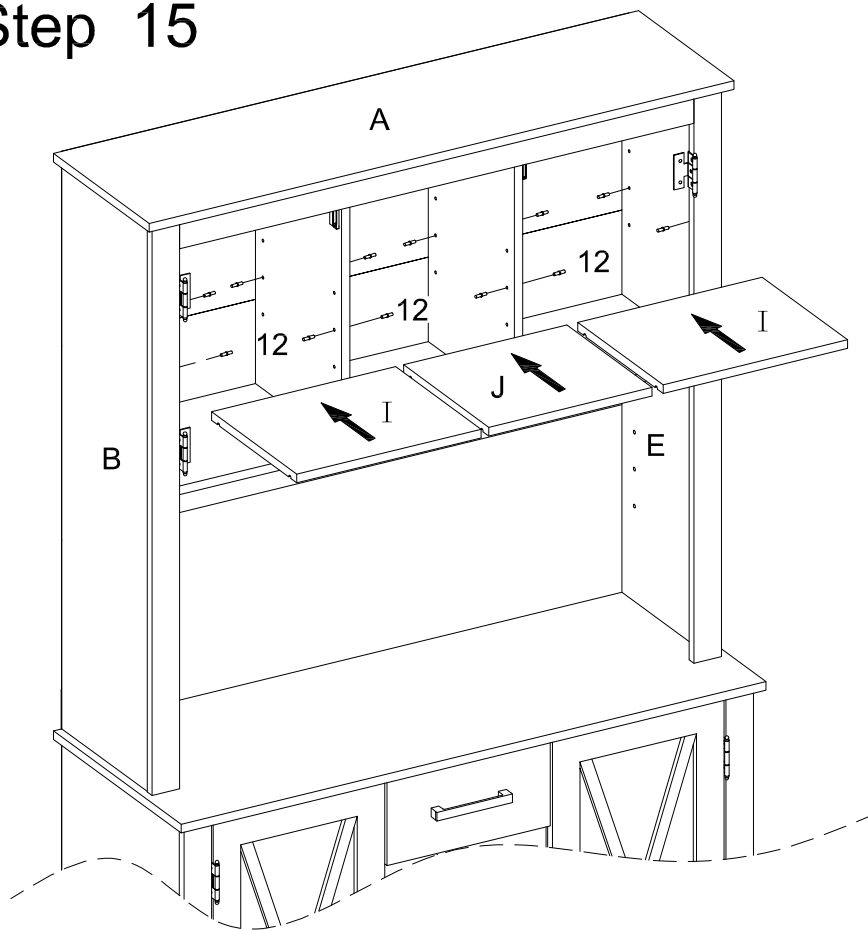

Step 16

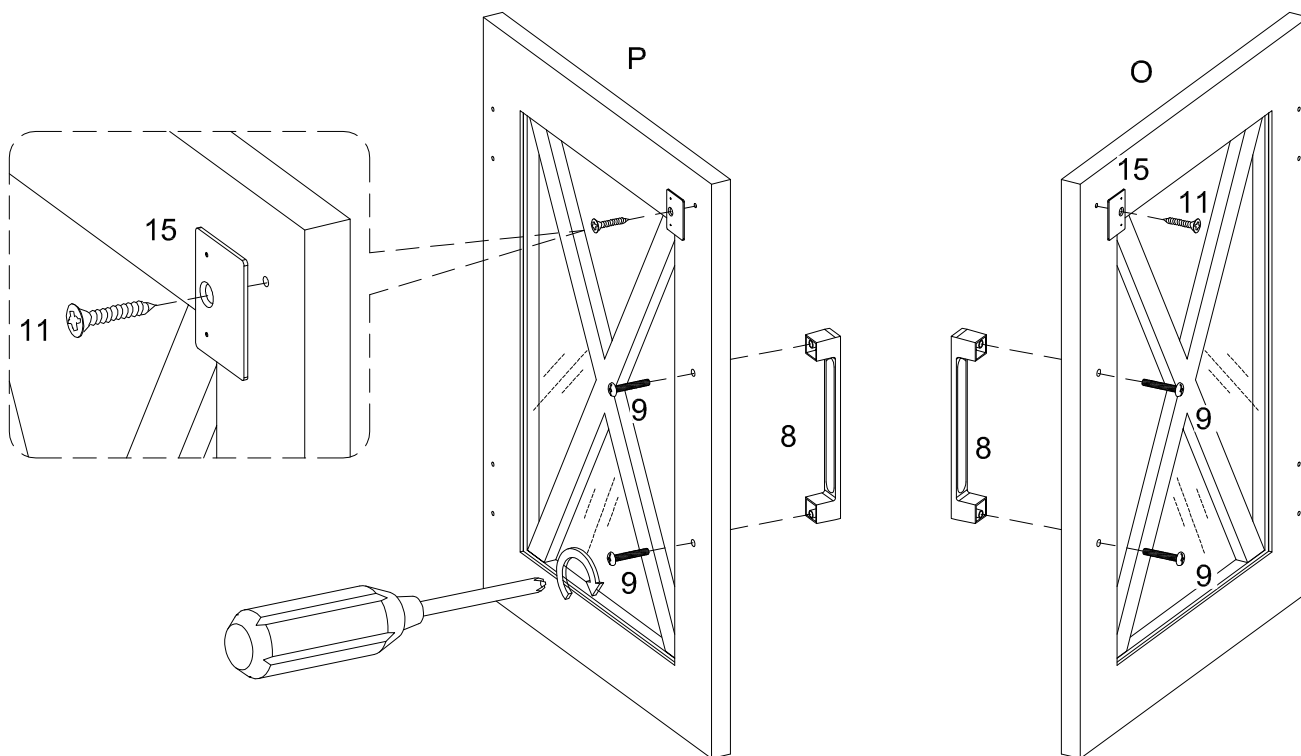

Step 17

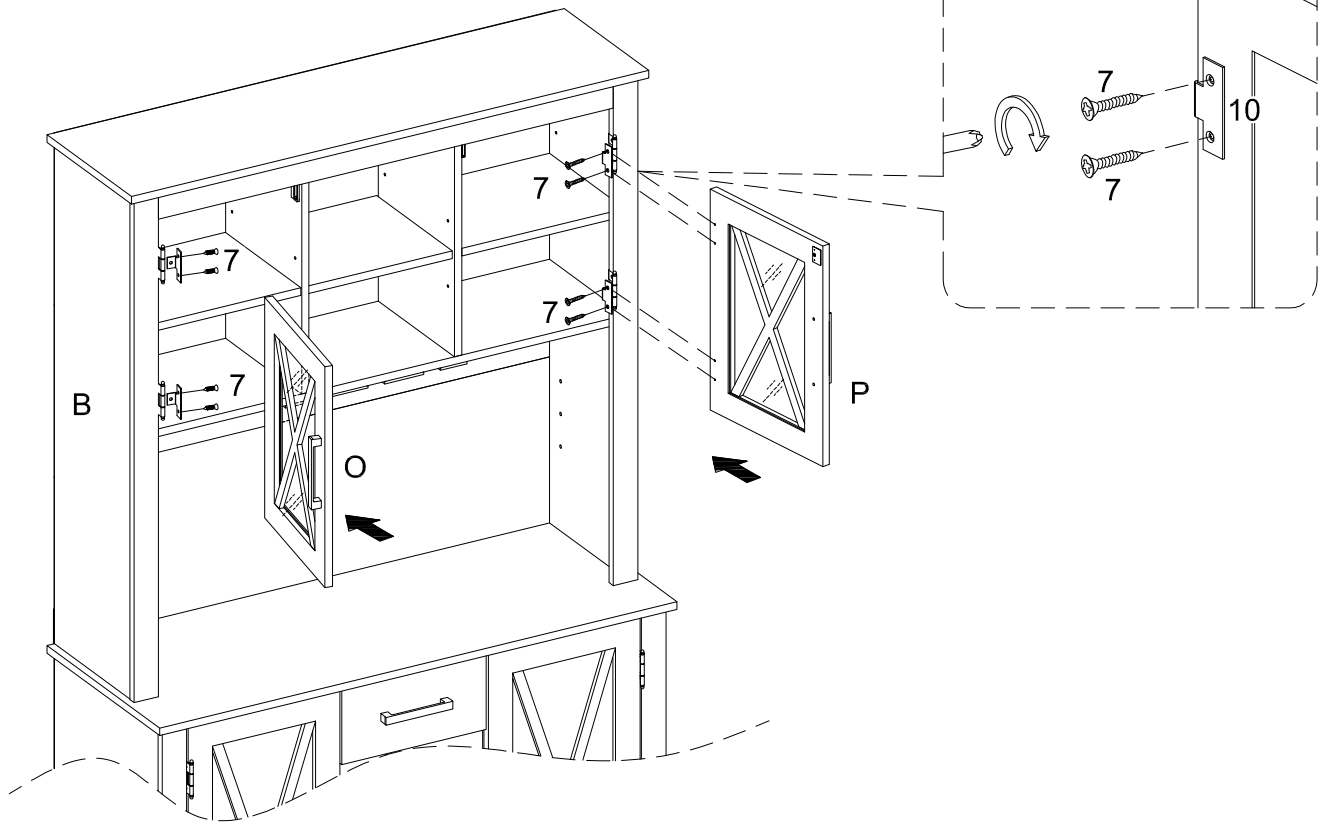

Step 18

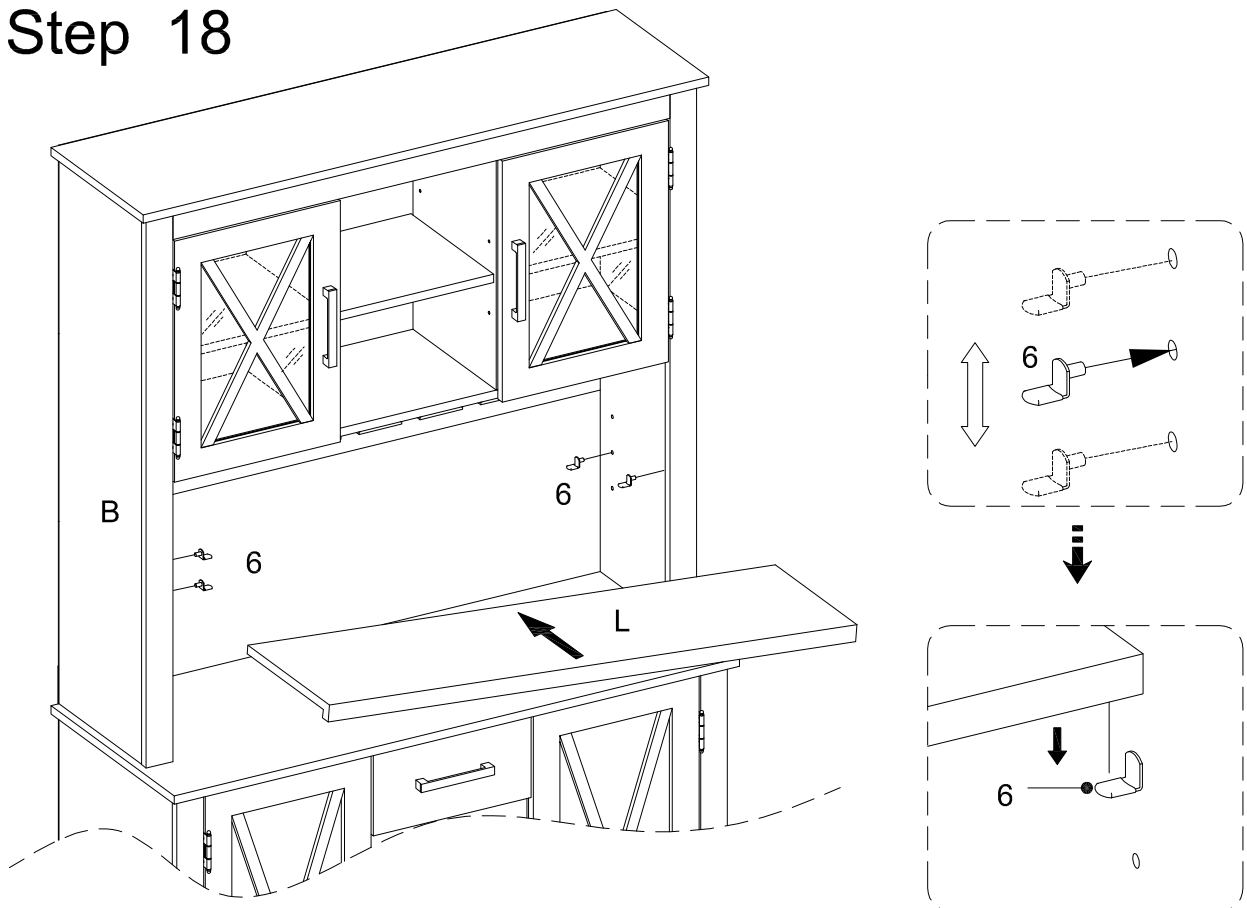

Step 19

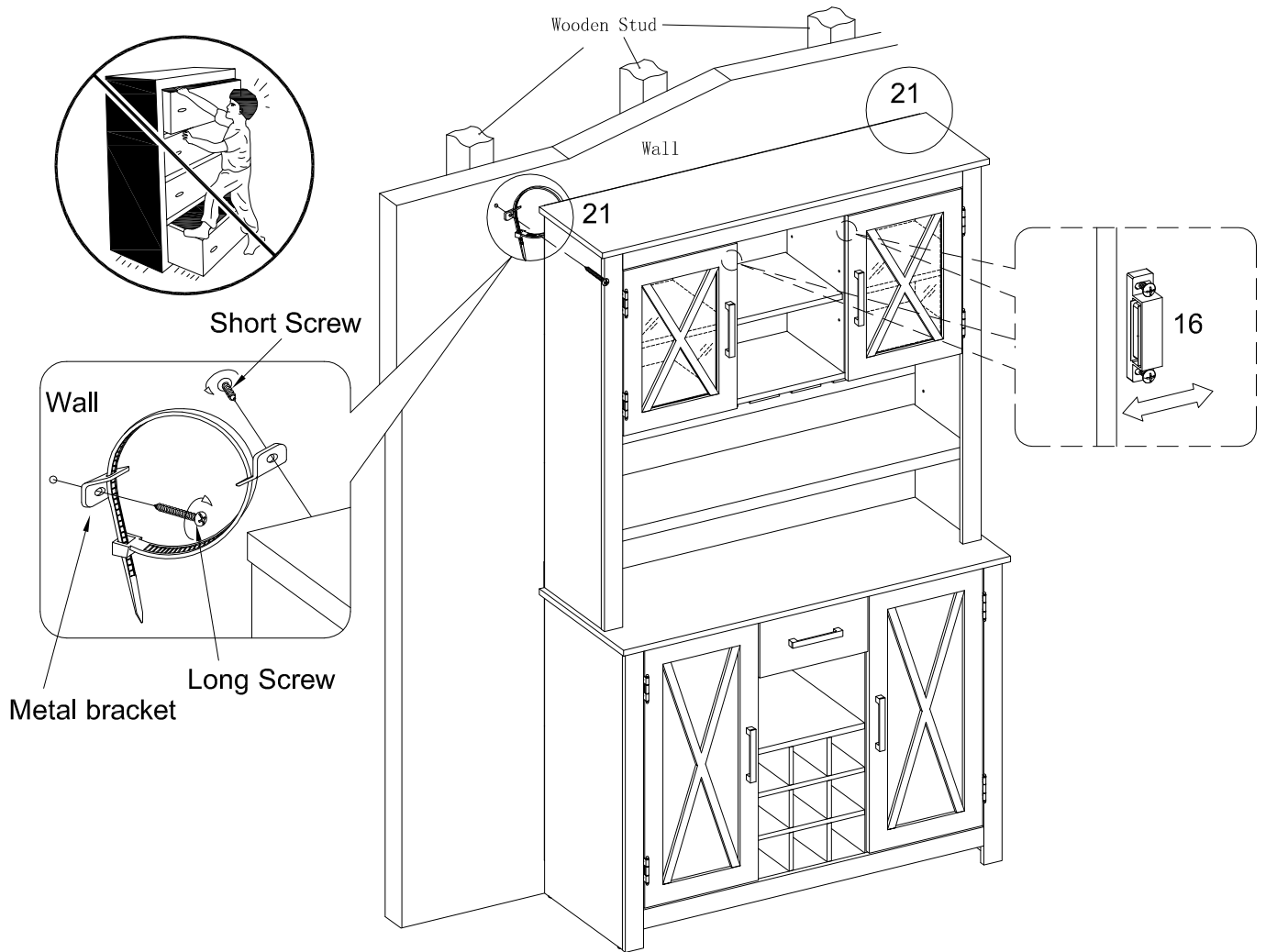

WARNING: ALL SCREWS MUST BE TIGHTENED!