

VANITY SET

ASSEMBLY INSTRUCTIONS



ASSEMBLY TIPS:











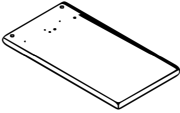

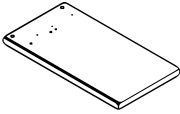
- 1.Remove hardware from box and sort by size.
- 2.Please check to see that all hardware and parts are present prior to start of assembly.
- 3.Please follow attached instructions in the same sequence as numbered to assure fast & easy assembly.

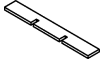

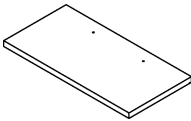
Warning !

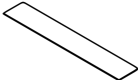
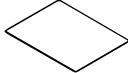
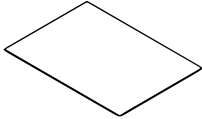
- 1.Don't attempt to repair or modify parts that are broken or defective.Please contact the store immediately.
- 2.This product is for home use only and not intended for commercial establishment.

PARTS IDENTIFICATION:

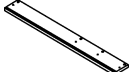
(A) LOWER LEFT SIDE PANEL		1PC	(J) LEFT DRAWER SIDE PANEL		1PC
(B) LOWER RIGHT SIDE PANEL		1PC	(K) RIGHT DRAWER SIDE PANEL		1PC
(C) LOWER CROSS PANEL		1PC	(L) LONG PARTITION PANEL		1PC
(D) LOWER BACK BOARD		1PC	(M) SHORT PARTITION PANEL		2PCS
(E) LOWER TOP PANEL		1PC	(N) DRAWER DIVIDER PANEL		1PC
(F) LARGE BACK PANEL		1PC	(O) LEFT DRAWER BOTTOM PANEL		1PC
(G) SMALL BACK PANEL		1PC	(P) RIGHT DRAWER BOTTOM PANEL		1PC
(H) DRAWER FRONT PANEL		1PC	(Q) UPPER LEFT SIDE PANEL		1PC
(I) DRAWER BACK PANEL		1PC	(R) UPPER RIGHT SIDE PANEL		1PC

(S) UPPER BOTTOM PANEL



1PC

(T) UPPER CROSS PANEL



2PCS

(U) UPPER TOP PANEL



1PC

(V) UPPER BACK PANEL

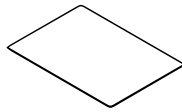

1PC

(W) MIRROR



1PC

(X) SEAT SIDE PANEL

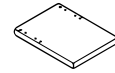

2PCS

(Y) SEAT BOTTOM PANEL



1PC

(AA) SEAT FRONT DIVIDER PANEL



1PC

(AB) SEAT BACK DIVIDER PANEL







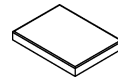



1PC

(AC) SEAT CUSHION

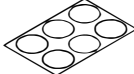

1PC

Z							
HARDWARE PACKAGE							
NO	DESCRIPTION	FIGURE	Q'TY	NO	DESCRIPTION	FIGURE	Q'TY
1	GLUE 40g		1PC	8	HANDLE L=120mm		1PC
2	WOODEN DOWEL ϕ 8x30mm		35PCS	9	HANDLE BOLT ϕ 4x20mm		2PCS
3	CAM BOLT ϕ 7x35.5mm		29PCS	10	EURO SLIDE L = 350mm		1SET
4	CAM LOCK ϕ 15x12mm		29PCS	11	SCREW FOR EURO SLIDE ϕ 3x12mm		12PCS
5	LONG SCREW ϕ 4.3x35mm		6PCS	12	DUAL EXTENSION SLIDE L = 375mm		1SET
6	PLASTIC FEET ϕ 15mm		8PCS	13	SCREW FOR DUAL EXTENSION SLIDE ϕ 3.5x12mm		12PCS
7	HOOK		10PCS	14	HINGE		2PCS

Z		HARDWARE PACKAGE					
NO	DESCRIPTION	FIGURE	Q'TY	NO	DESCRIPTION	FIGURE	Q'TY
15	HINGE SCREW ϕ 4x15mm		14PCS	20	FIXER		8PCS
16	PIPE THREAD ϕ 6.2x45mm		2PCS	21	FIXER SCREW ϕ 3x19mm		8PCS
17	LARGE BOLT ϕ 4.5x20mm		2PCS	22	RING BOX		1PC
18	METAL PLATE 4.5x12.3x1.2mm		2PCS	23	STICKER ϕ 20mm		5PCS
19	METAL PLATE SCREW ϕ 3x15mm		4PCS				

STEP 1

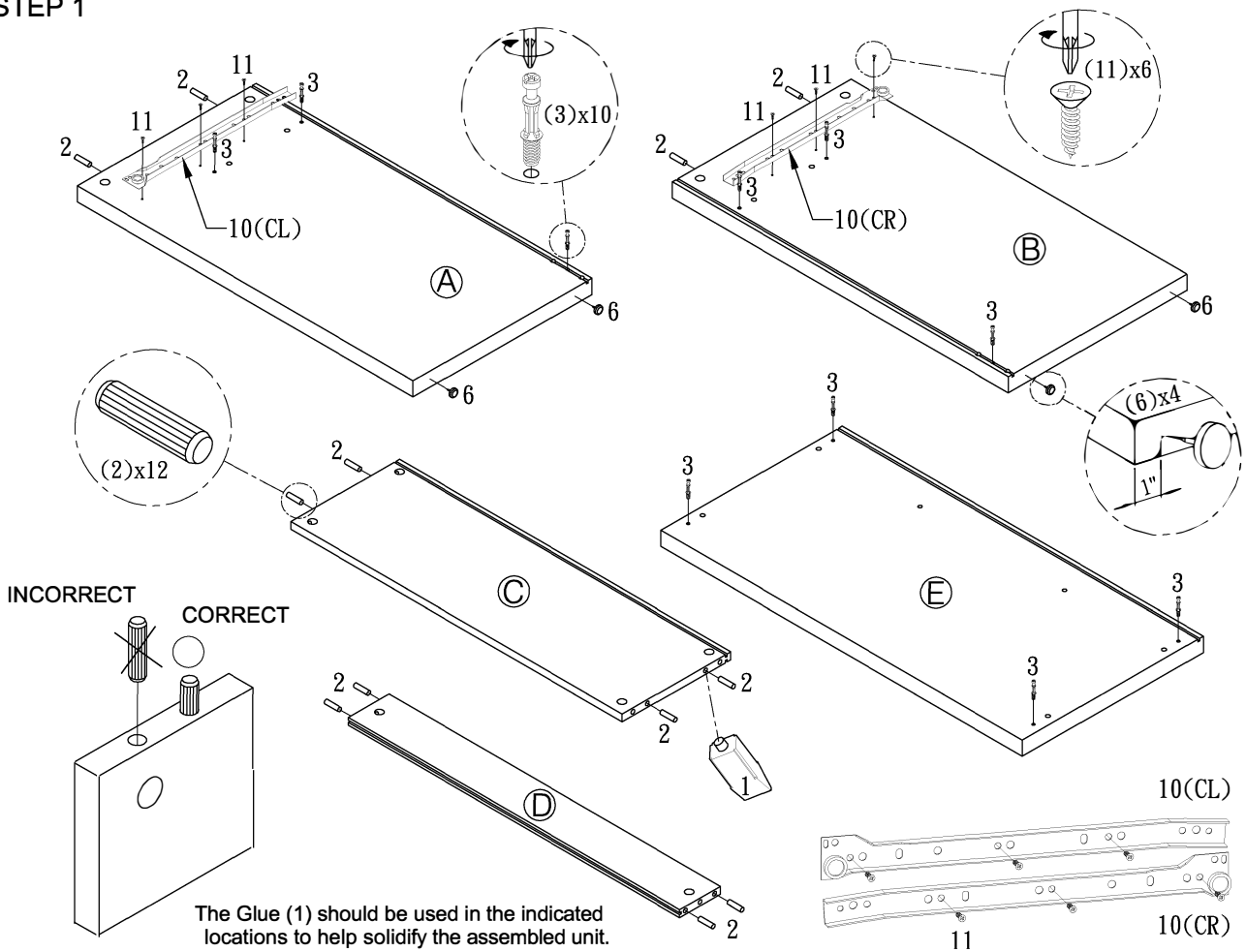

STEP 2

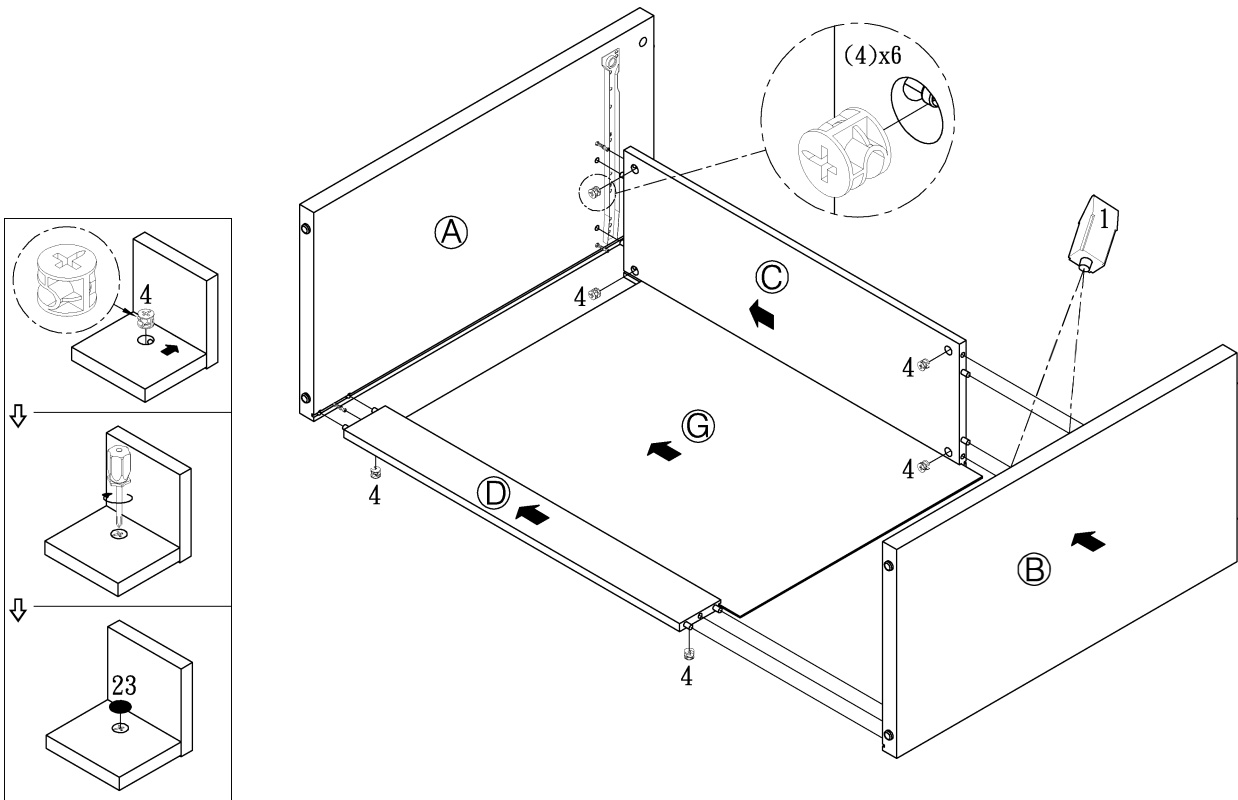

STEP 3

The Glue (1) should be used in the indicated locations to help solidify the assembled unit.

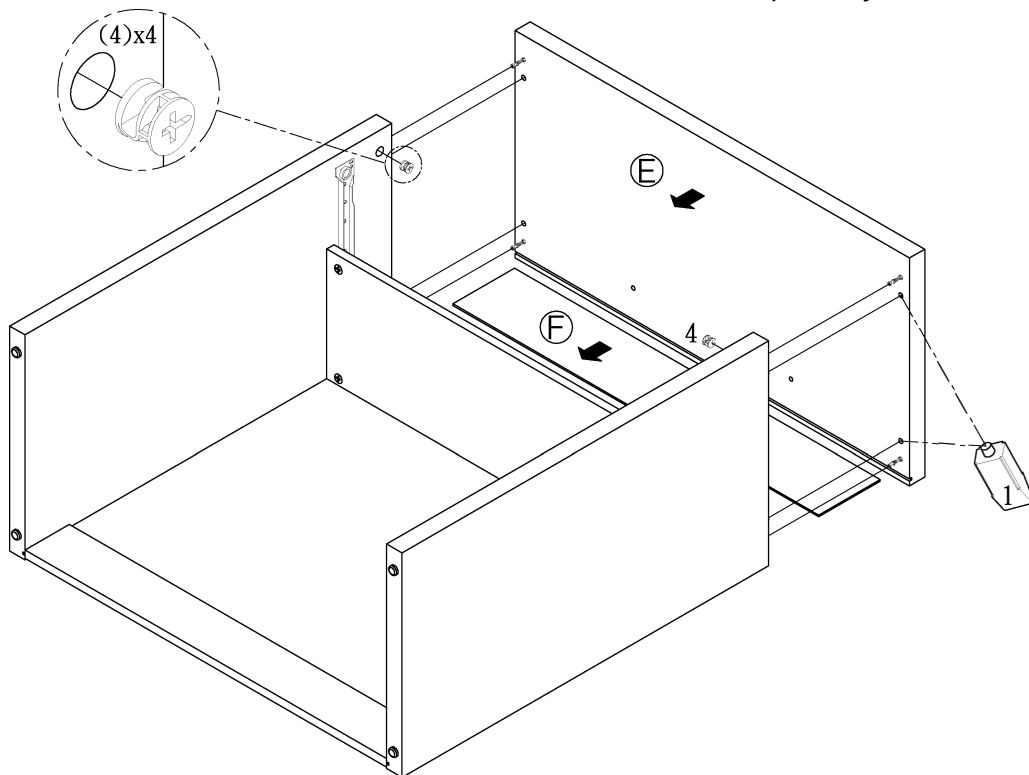

STEP 4

The Glue (1) should be used in the indicated locations to help solidify the assembled unit.

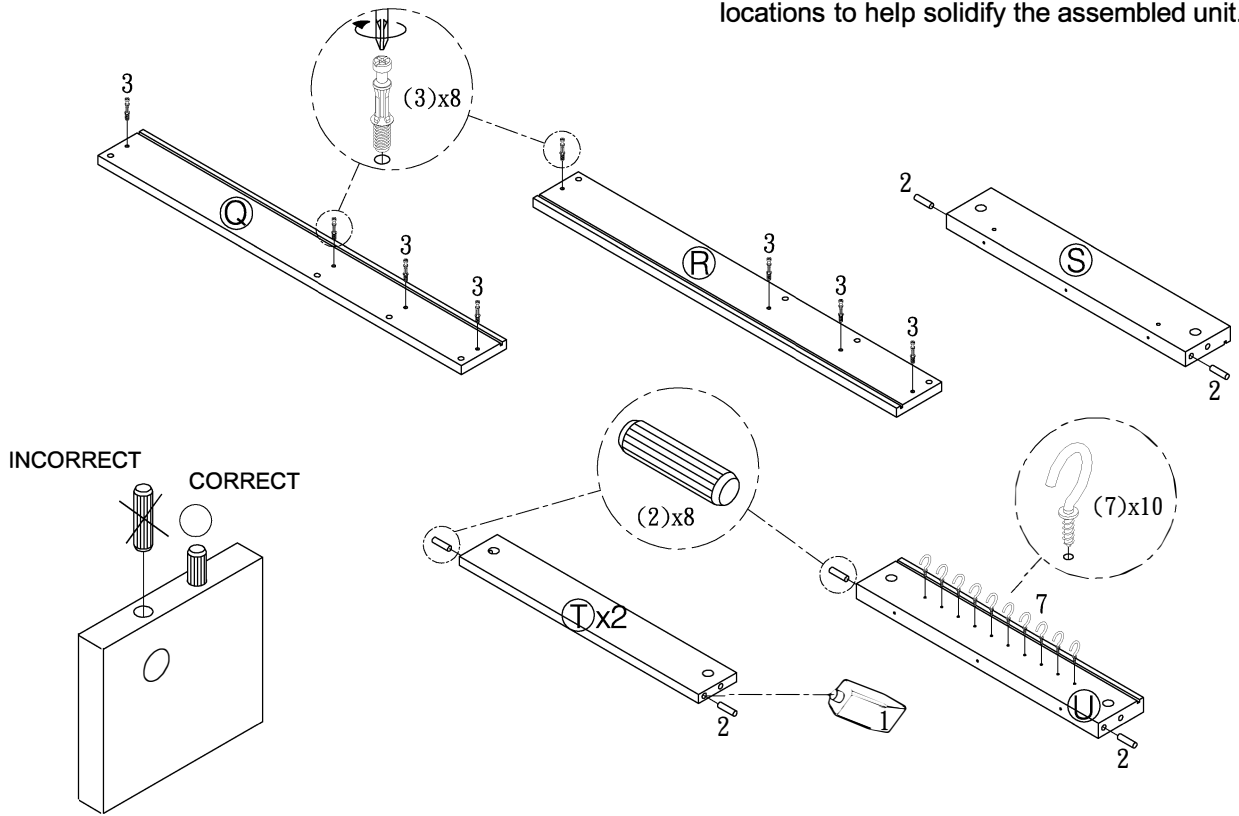

STEP 5

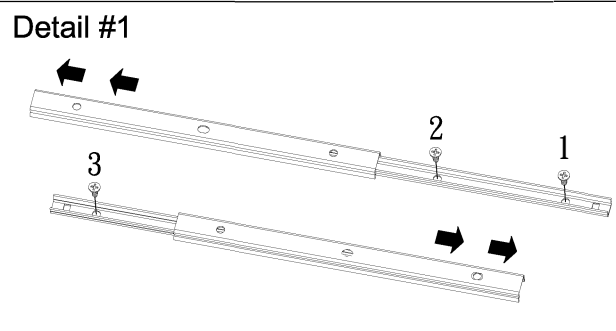
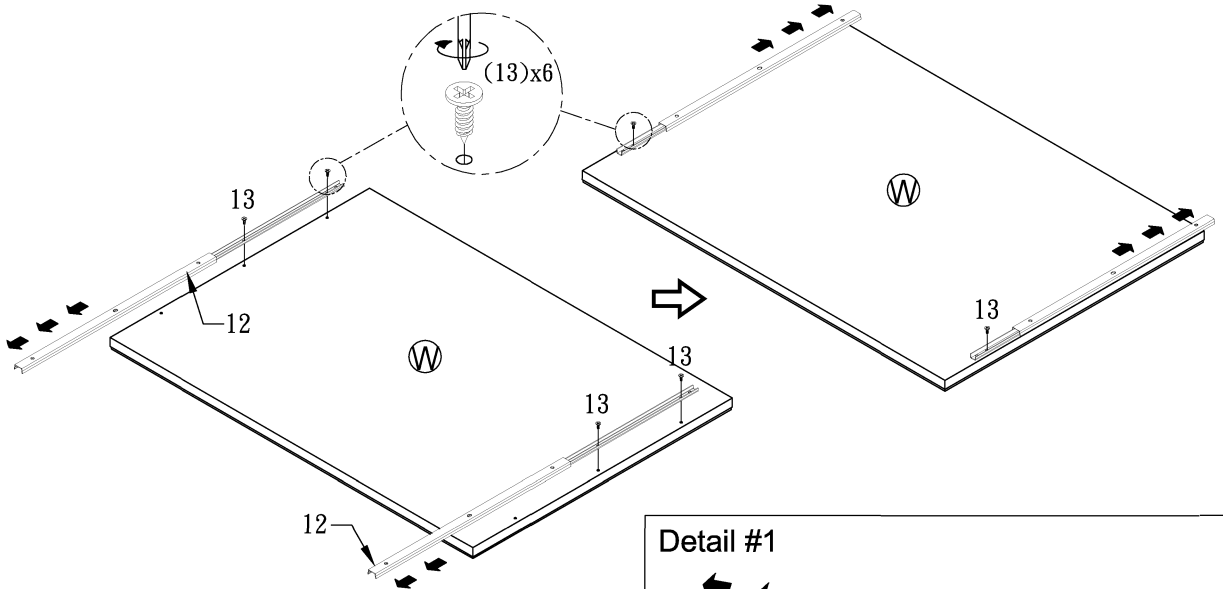

STEP 6

The Glue (1) should be used in the indicated locations to help solidify the assembled unit.

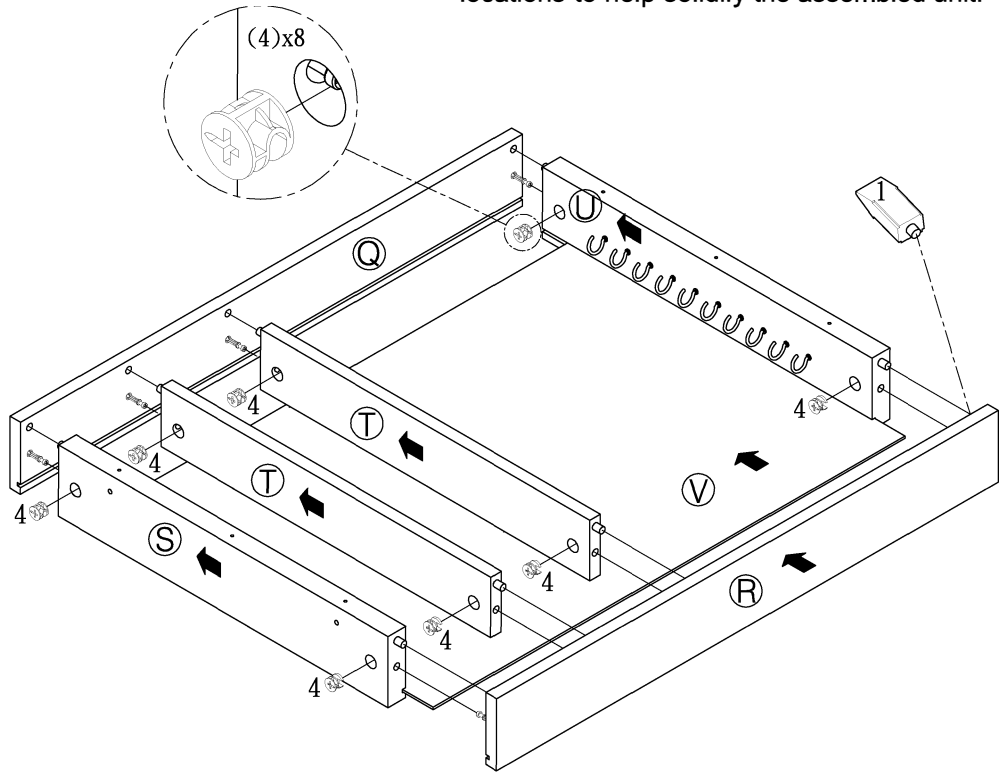
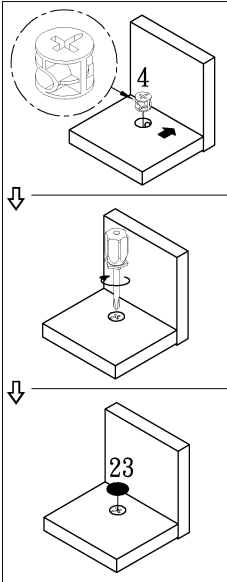

STEP 7

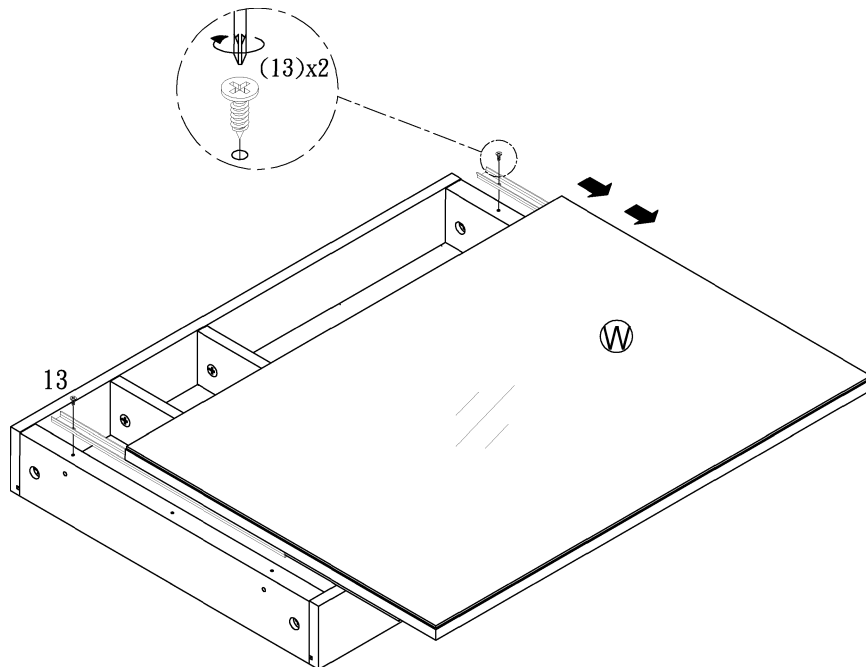

STEP 8

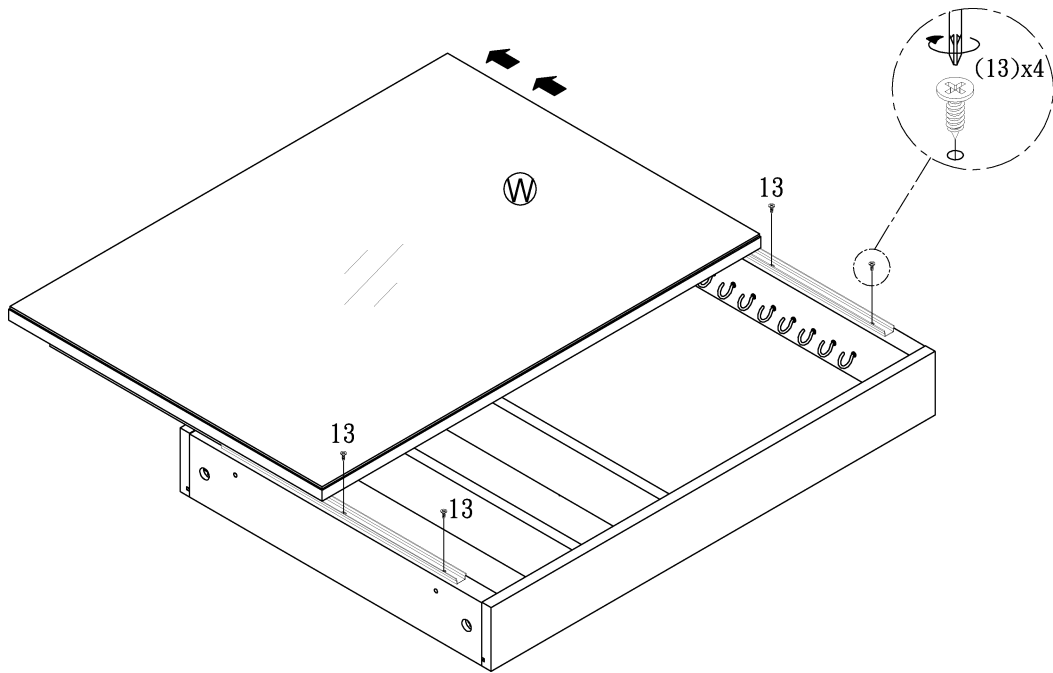

STEP 9

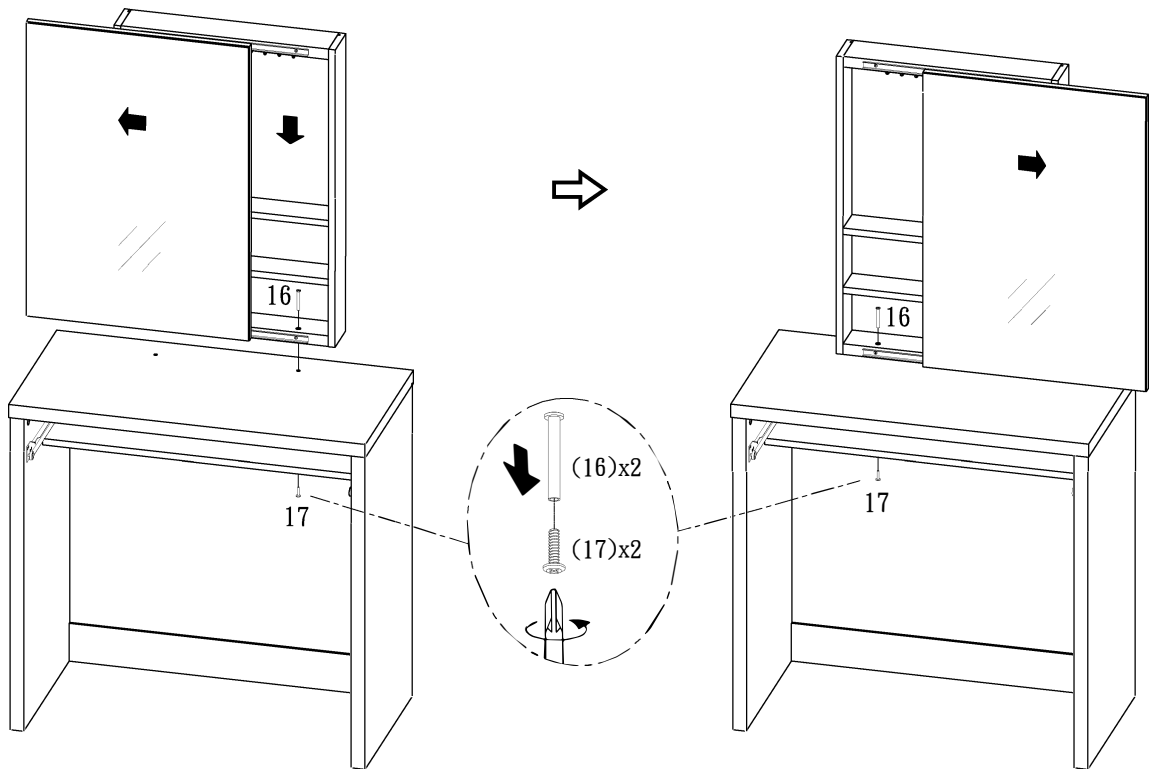

STEP 10

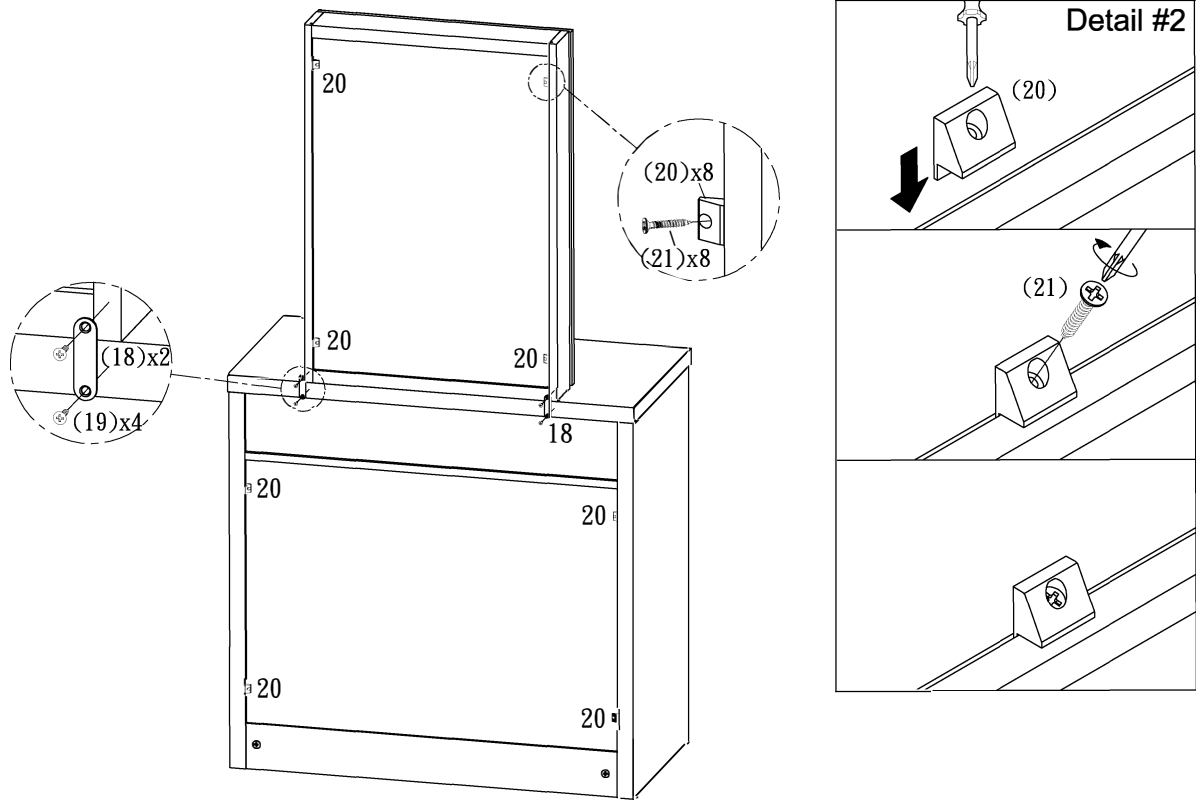

STEP 11

The Glue (1) should be used in the indicated locations to help solidify the assembled unit.

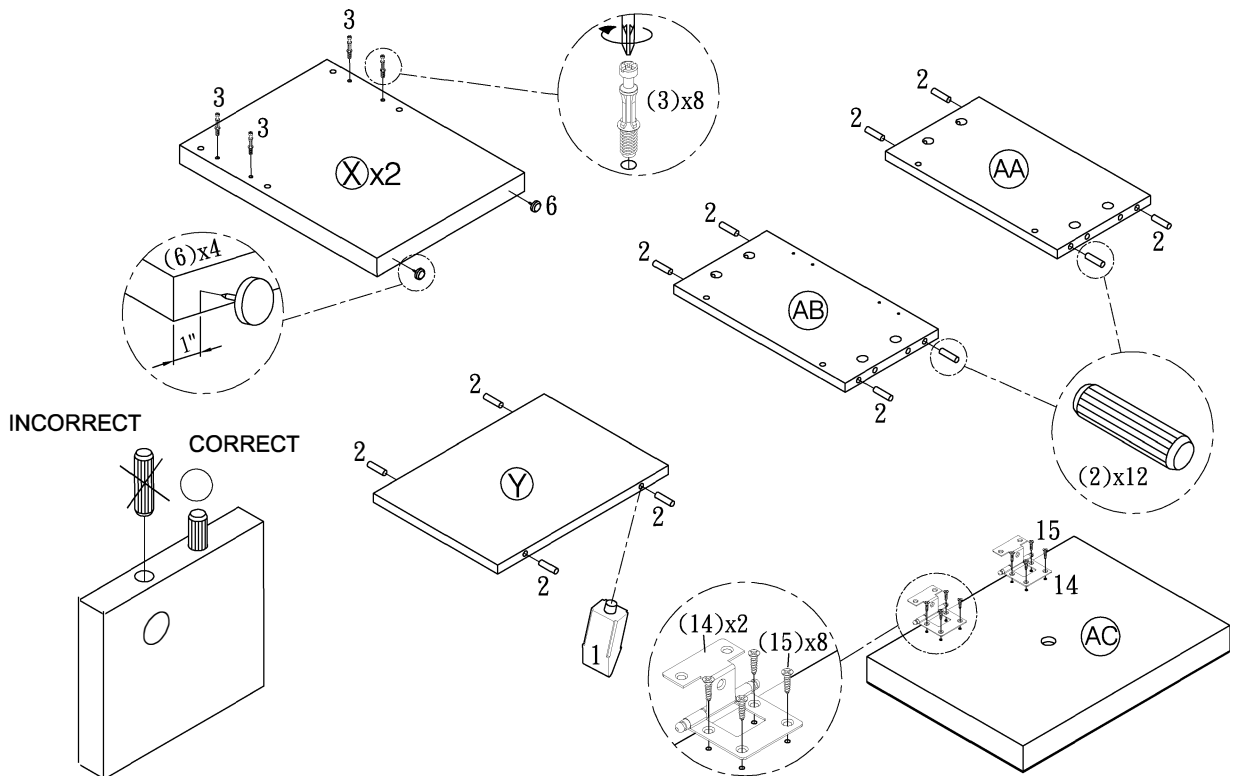

STEP 12

The Glue (1) should be used in the indicated locations to help solidify the assembled unit.

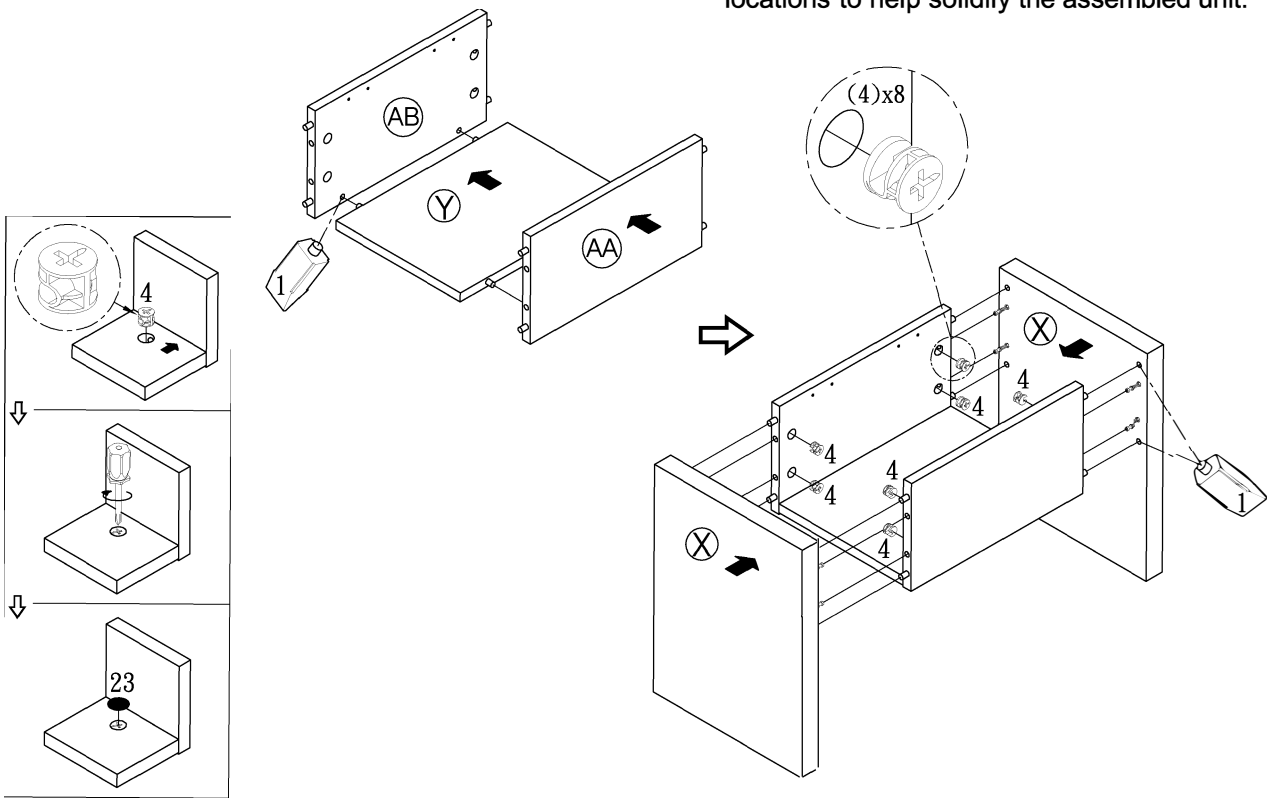

STEP 13

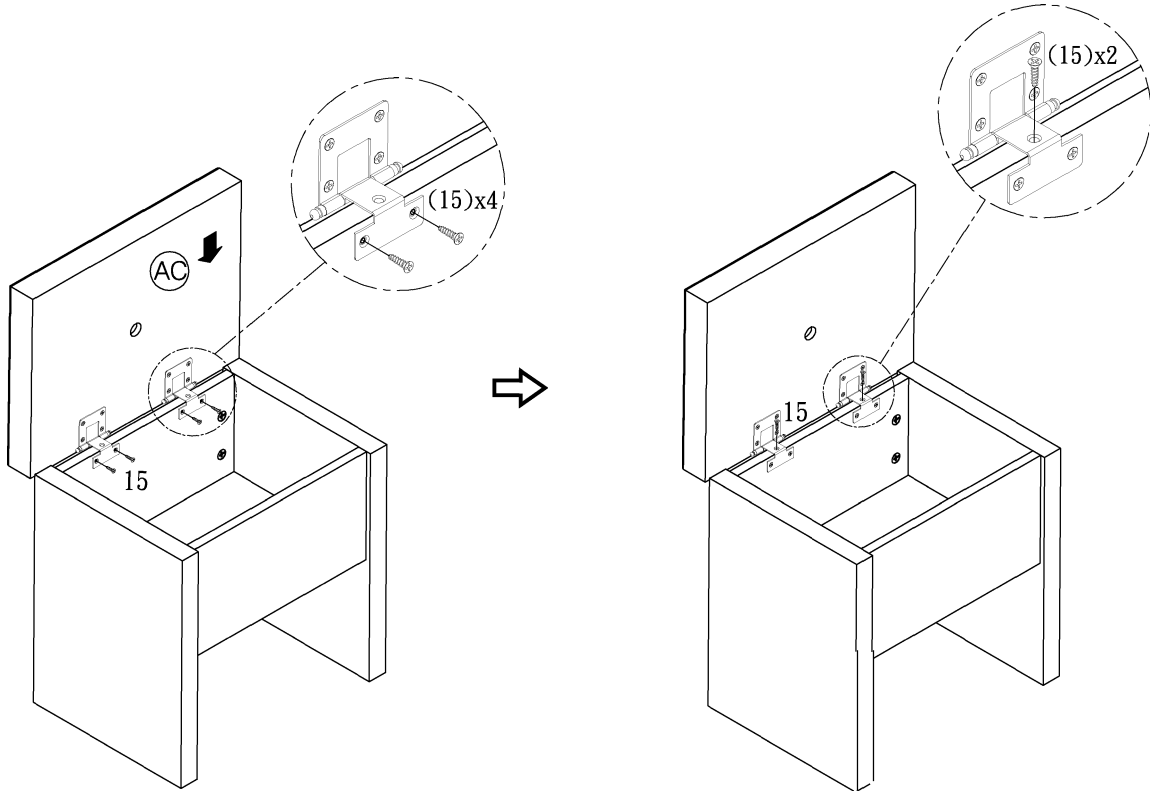

STEP 14

The Glue (1) should be used in the indicated locations to help solidify the assembled unit.

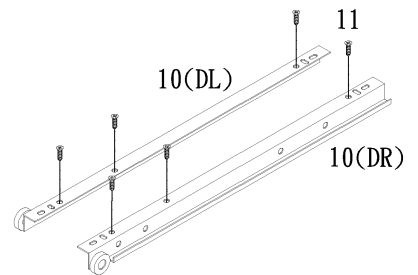
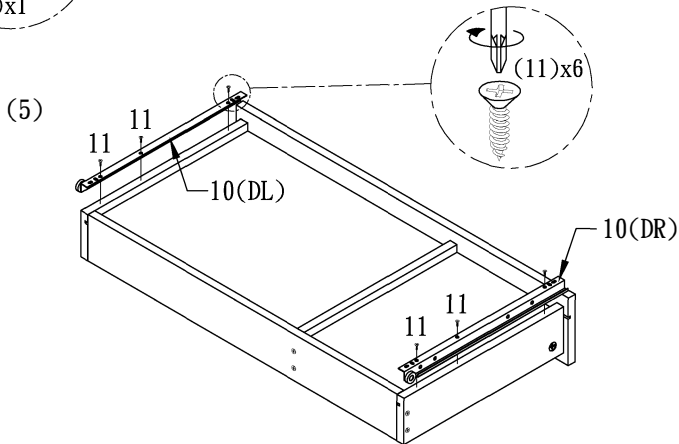
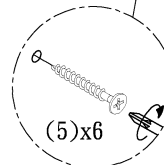
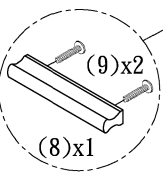
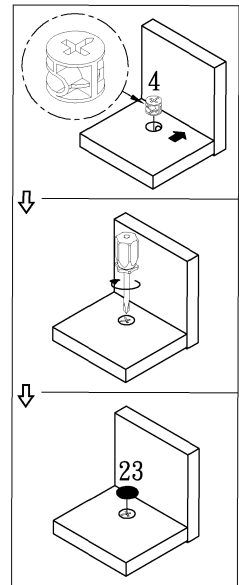
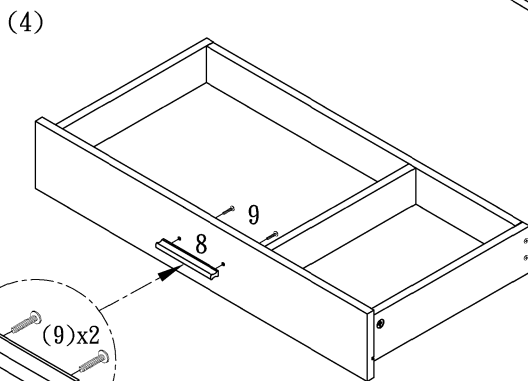
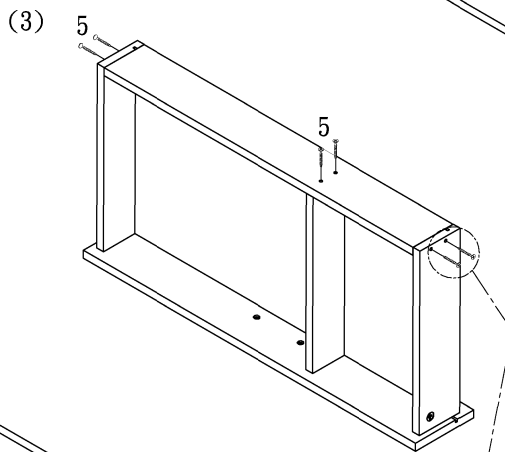
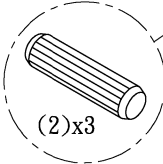
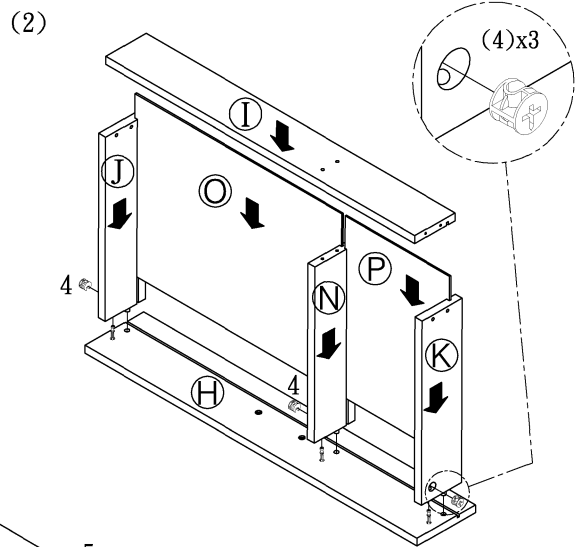
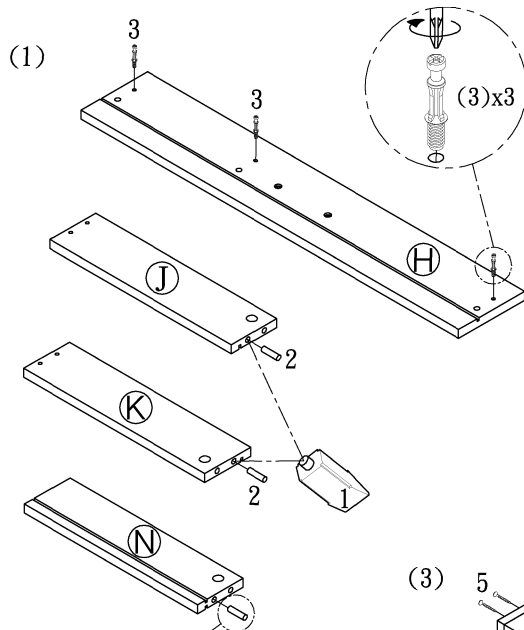

STEP 15

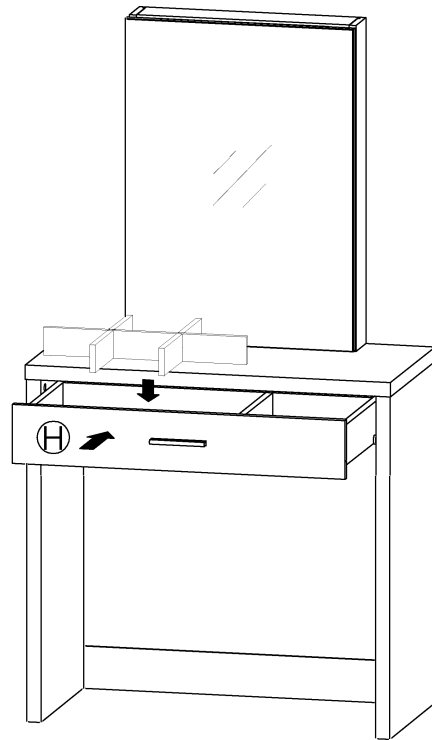
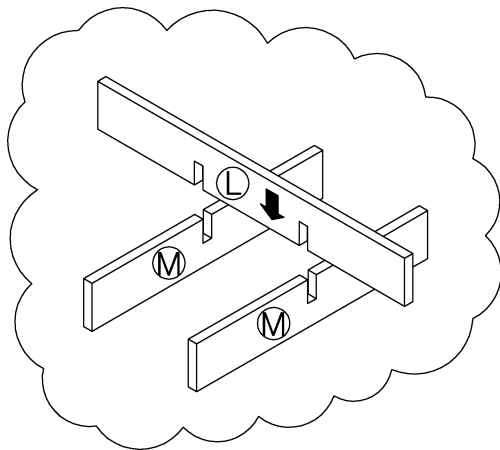

STEP 16

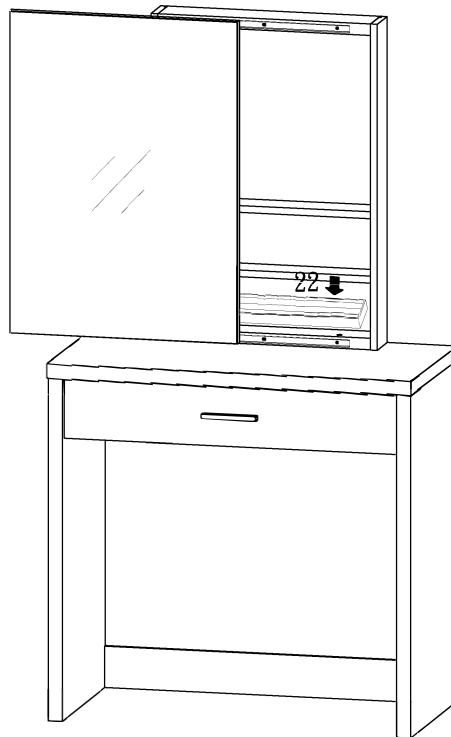
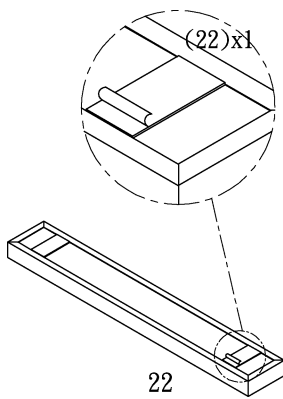

FINISH

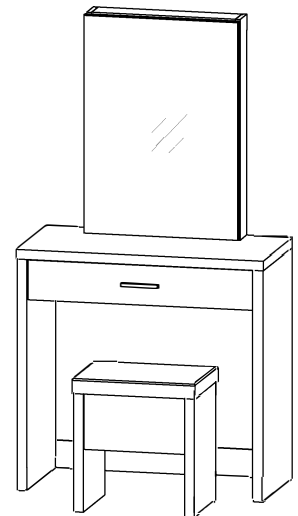

Assembly Instruction as below:

Step 1: Insert (2) into the holes at two sides of (C)/(D) , Insert (2) into the holes at top side of (A)/(B) , Insert (3) into the holes on the (A)/(B)/(E) , Nail (6) at bottom of (A)/(B) , then (10-CL) on (A) , (10-CR) on (B) by (11).

Step 2: Connect (C)/(D) with (A) , when (3) is connected inside (4) , tightly fasten (4) clockwise. Insert (G) on and between (C)&(D) along slots. Apply the same technique to connect (C)/(D) with (B).

Step 3: Insert (F) on and between (A)&(B) along slots , then connect (E) to (A)/(B).

Step 4: Insert (2) into the holes at two sides of (S)/(T)/(U) , Insert and screw (3) into the holes on the (Q)/(R) , Insert and screw (7) into the holes on the (U).

Step 5: Attach (12) on (W) by (13). See detail #1.

Step 6: Connect (S)/(T)/(U) with (Q) , insert (V) on and between (S)&(U) along slots , then connect (R) with (S)/(T)/(U).

Step 7: Connect (W) with (S)&(U) by (13).

Step 8: Connect (W) with (S)&(U) by (13).

Step 9: Connect (E) with step 9 by (16)&(17).

Step 10: Attach two Metal plate (18) to the joints of (E) & slide mirror by (19) , insert (20) into the gap at the back of unit by (21).

Step 11: Insert (2) into the holes at two sides of (Y)/(AA)/(AC) , Insert (3) into the holes on the (X) , Nail (6) at bottom of (X) , screw (14) at bottom of (AC) by (15).

Step 12: Connect (AA)/(AB) with (Y) , connect (X) with (AA)/(AB) , when (3) is connected inside (4) , tightly fasten (4) clockwise.

Step 13: Connect (AC)&(AB) with (14) by (15).

Step 14-1: Insert (2) into the holes at top of (J)/(K)/(N) , insert and screw (3) into the holes on the (H).

14-2: Fasten (J)/(K)/(N) on (H) , insert (O)/(P) on and between (J)&(N) , (K)&(N) along slots , then attach (I) on (J)/(K)/(N).

14-3: Fasten (I) on (J)/(K)/(N) by (5).

14-4: Attach (8) on (H) by (9).

14-5: Attach (10-DL) at bottom of (J) and (10-DR) at bottom of (K) by (11).

Step 15: Connect (M) with (L) by fitting the cutouts together.

Step 16: Place Ring box (22) into the slide mirror.

(Tear off the Double-sided Tape before using.)