

---

**NOTICE:** This product is shipped in 2 separate packages. They may NOT arrive at the same time. Please wait until you have received BOTH boxes before starting assembly.

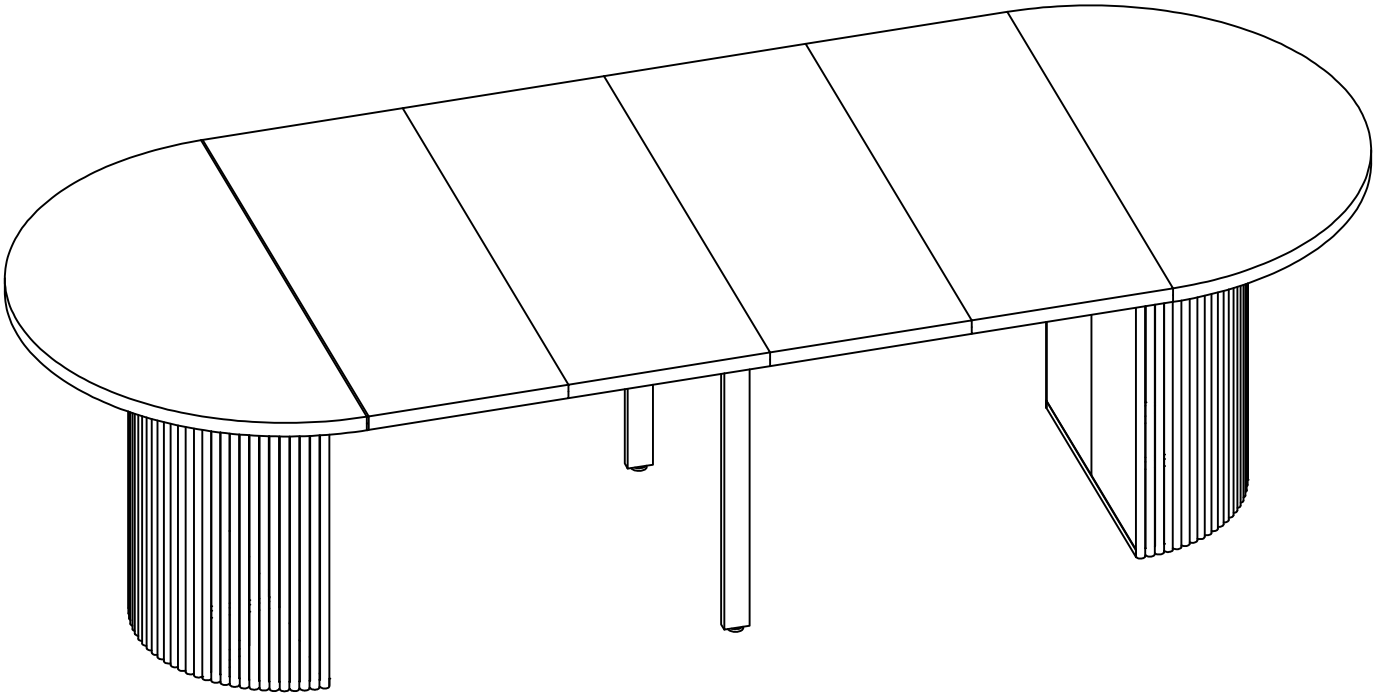

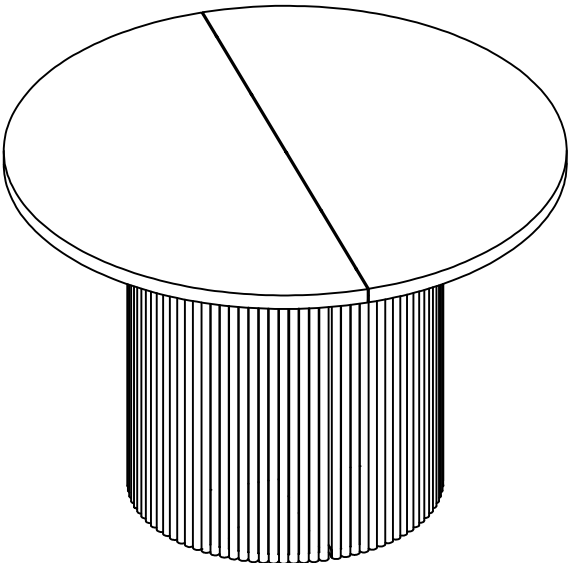

## **Expert Tips for a Perfect Assembly:**

**1. Check Twice, Screw Once:** Carefully distinguish between different screw lengths. Using the wrong screw can permanently damage the surface.

**2. Alignment is Key:** Ensure the two tabletop parts (Part 1 & 2) are seamlessly joined and locked before final tightening of the slide rails.

**3. Smooth Operation:** Periodically apply a small amount of lubricant to the slide rails if the expansion becomes stiff.

**4. Safety First:** This is a heavy item. We recommend two people for assembly to prevent injury or damage to the product.

**5. Regular maintenance:** It is recommended to check the bottom screws for looseness every 3 months.

**6. Weight Distribution:** After extension, place weight evenly and do not concentrate loads on the edges.



1. Verify screw length before inserting to avoid damaging the tabletop.



**D:** M5×12mm

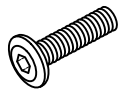

**E:** M6×30mm

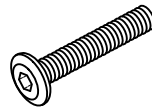













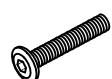

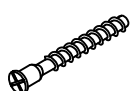

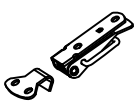
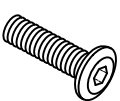
**F:** M6×45mm

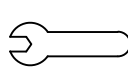

**U:** M6×12mm

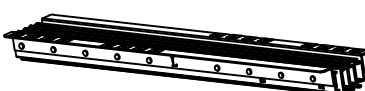
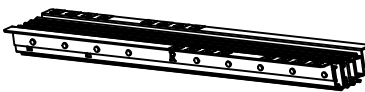
2. Check Part L & Part R: Please verify you have one Left Slide Rail (L) and one Right Slide Rail (R) before proceeding.

A×24PCS	B×1PC	C×22PCS	D×32PCS	E×12PCS	F×8PCS
 M6×25mm	 M4mm	 Ø6×30mm	 M5×12mm	 M6×30mm	 M6×45mm
G×46PCS	H×3PCS	I×16PCS	J×3PCS	K×3PCS	M×10PCS
 Ø4×12mm	 Ø4×18mm	 Ø5×50mm			
N×4PCS	O×2PCS	P×8PCS	Q×40PCS	S×1PC	T×1PC
 M8×30mm		 M6mm	 6mm		 M5mm
U×4PCS	L×1PC		 		
 M6×12mm	R×1PC				

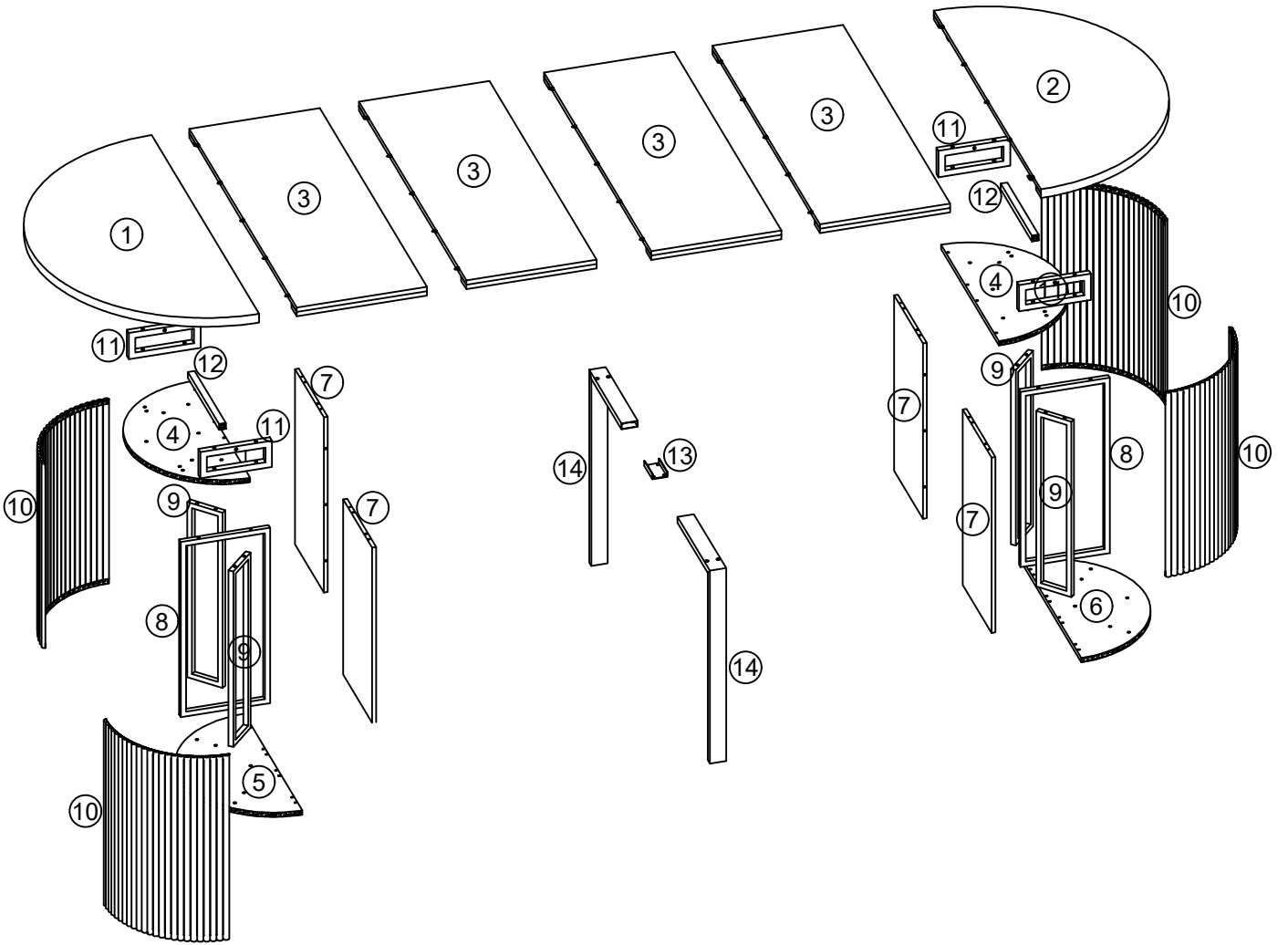

1.

C×6PCS



Ø6×30mm

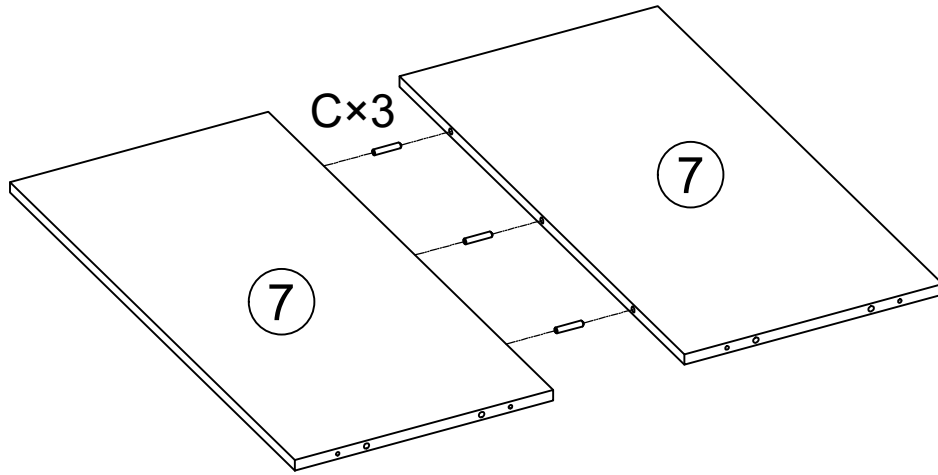

×2

2.

C×8PCS



Ø6×30mm

I×8PCS



Ø5×50mm

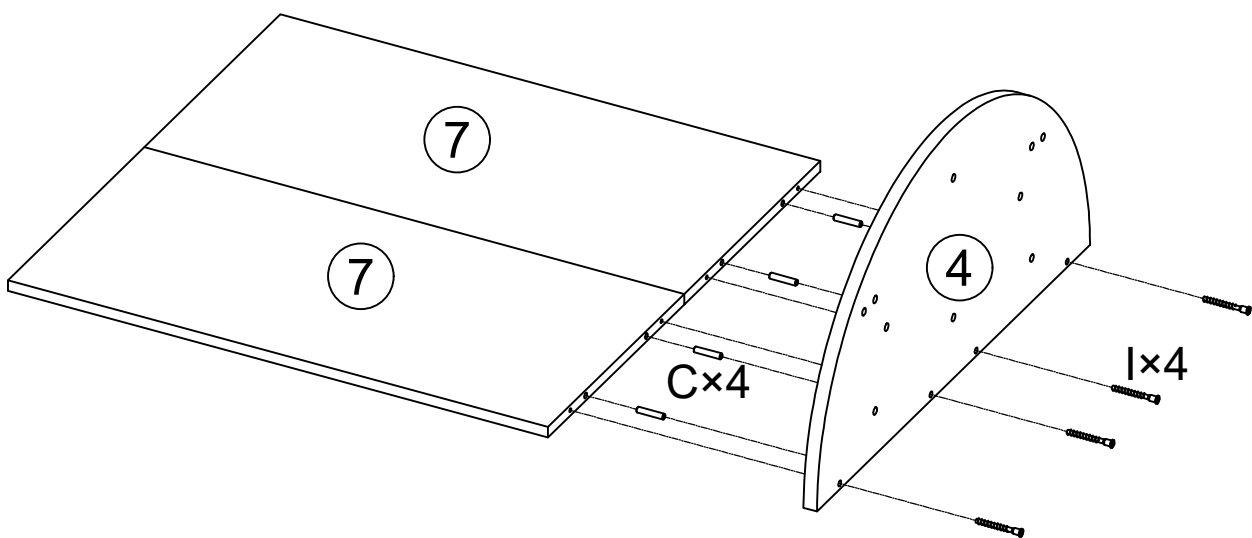



×2

A×12PCS

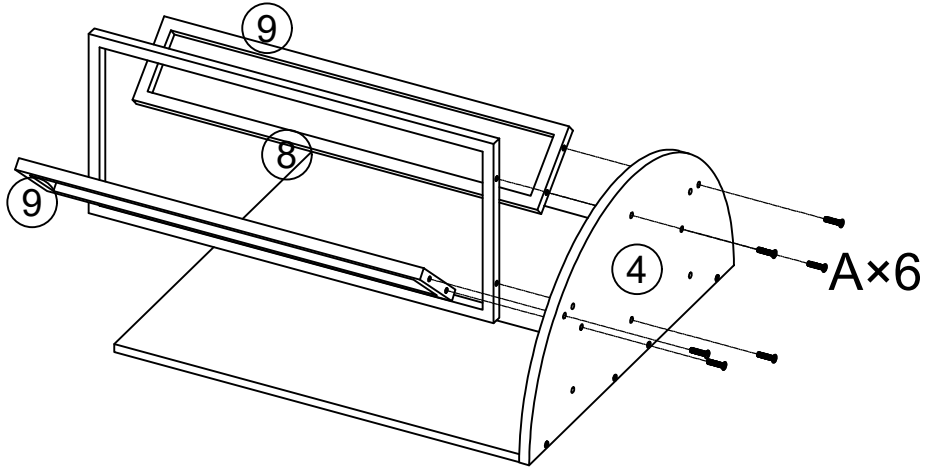
M6×25mm

3.





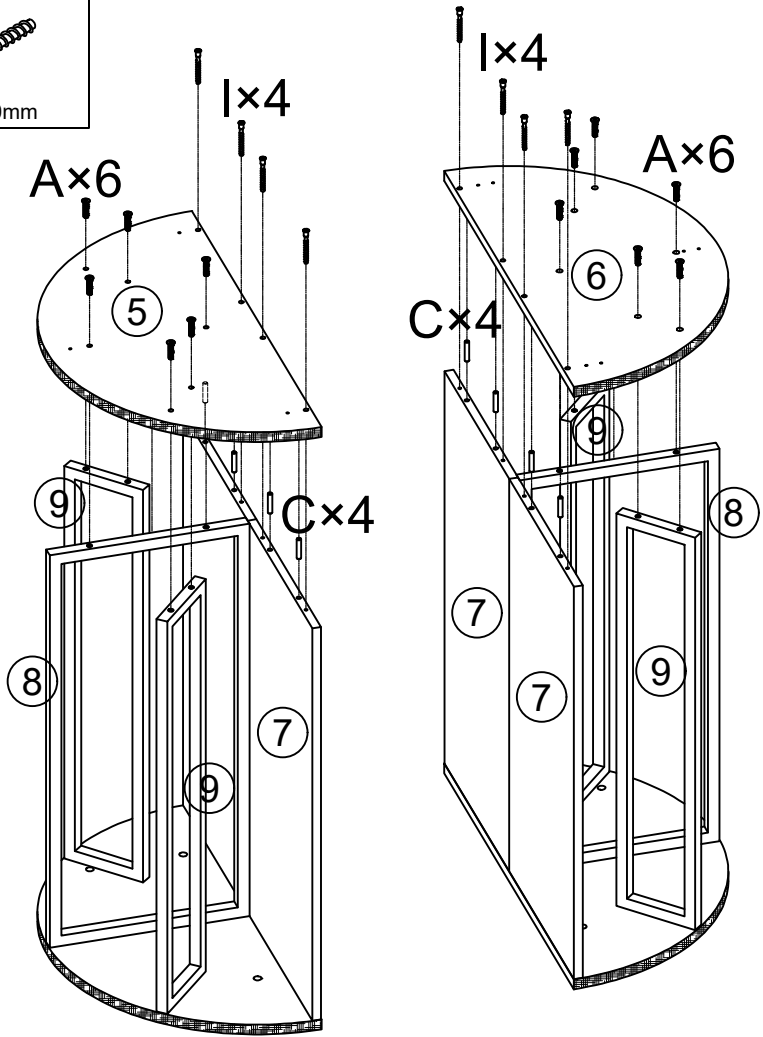

×2

A×12PCS	C×8PCS	I×8PCS
		
M6×25mm	Ø6×30mm	Ø5×50mm

4.



# 5.



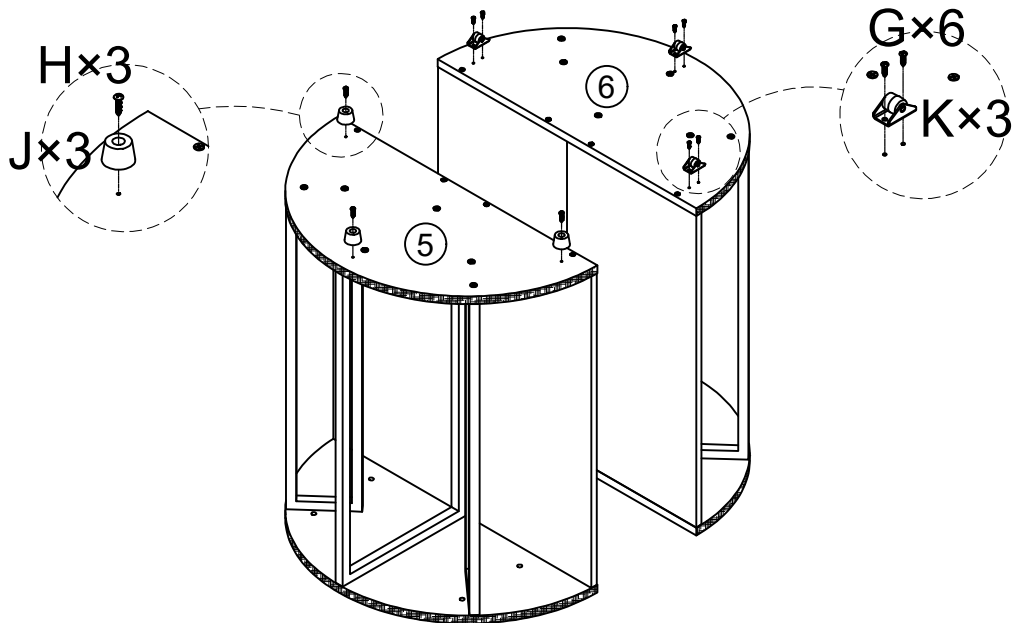

G×6PCS	H×3PCS	J×3PCS	K×3PCS
			
Ø4×12mm	Ø4×18mm		

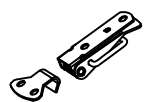

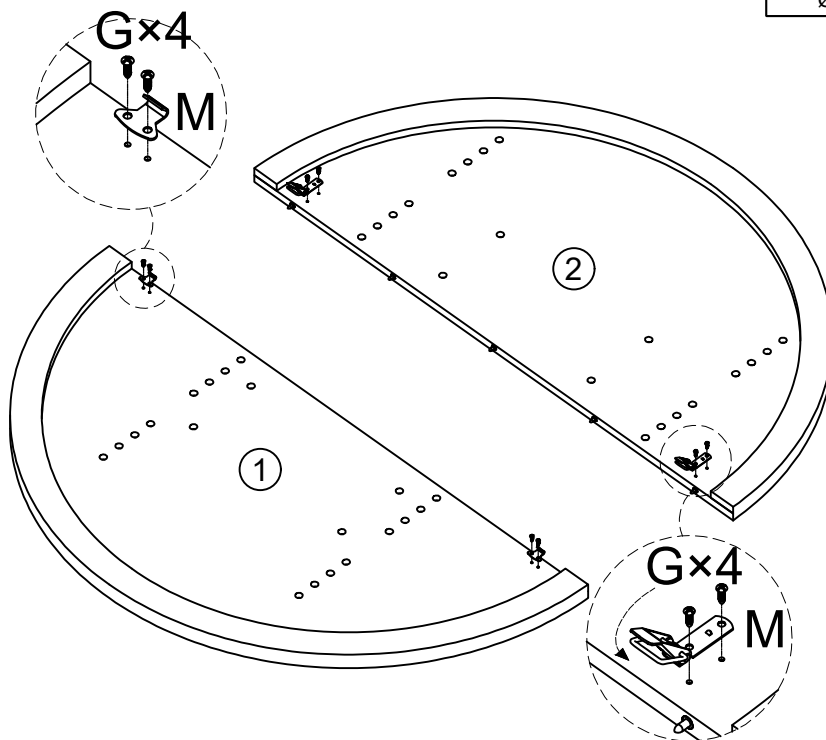
# 6.

G×8PCS	M×2PCS
	
Ø4×12mm	

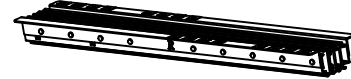

D×32PCS	B×1PC	Q×32PCS	L×1PC	
			R×1PC	
M5×12mm	M4mm	6mm		

7.



1. Please fasten the lock catch first before connecting the table top with the slide rail.
2. Ensure that Part① table top and Part② table top are joined without any gaps before securing the slide rail.
3. Pls take attention that you should place the gaskets in position first when tighten the screw to the slide rail.

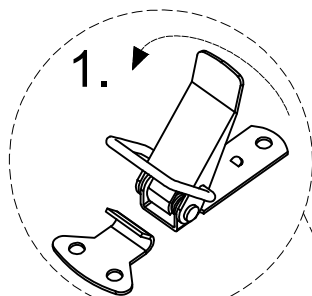

Fully Unfolded

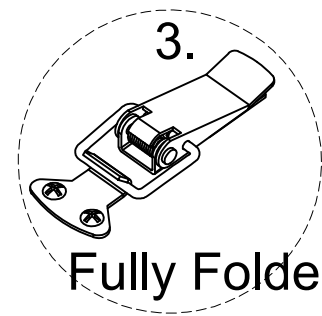
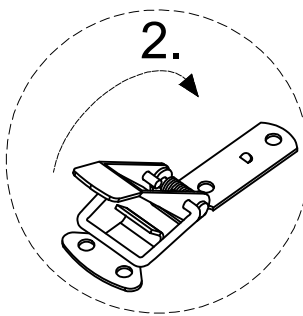

Fully Folded

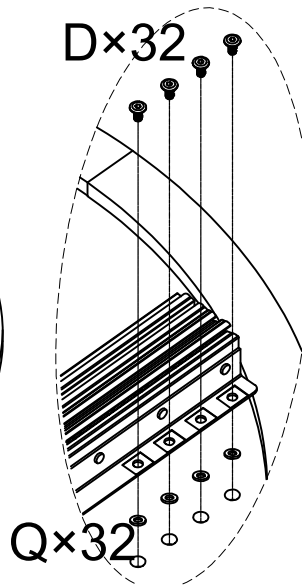
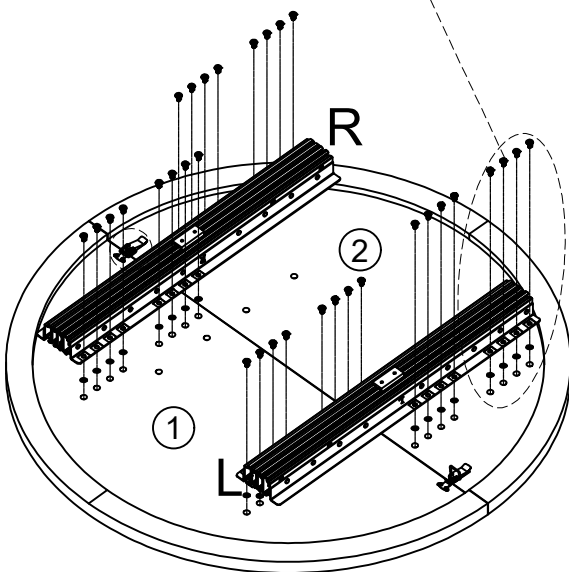

**STOP! Double check:** Are you using the M5x12mm (**Part D**) screws here? Using longer screws will damage the tabletop surface.

8.

E×12PCS

B×1PC



M6×30mm



M4mm

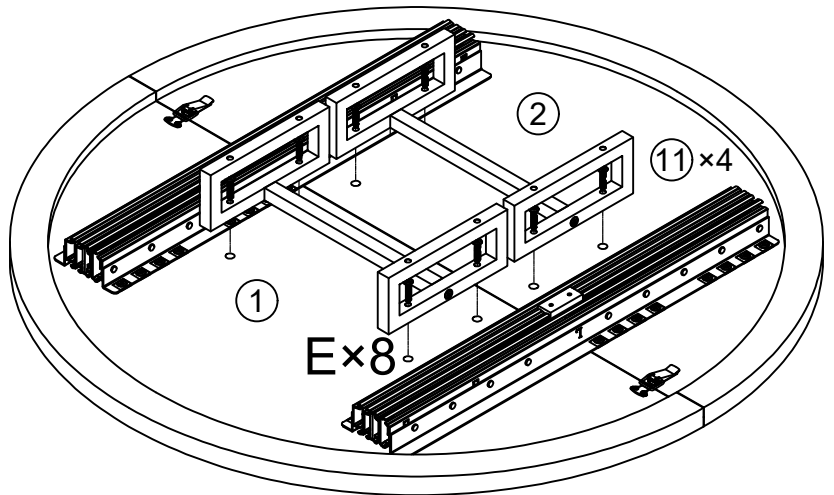
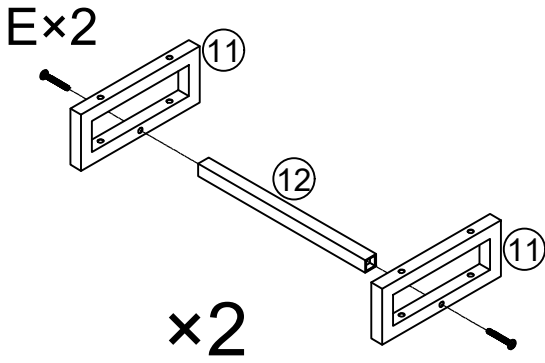

9.

F×8PCS

P×8PCS

Q×8PCS

B×1PC

S×1PC

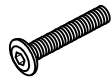

M6×45mm



M6mm



6mm



M4mm

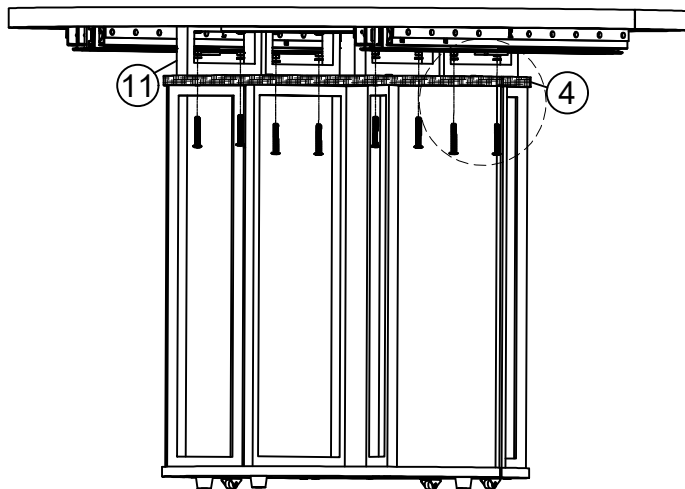
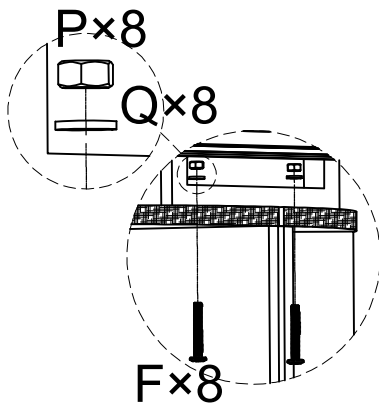
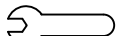



If the trim strip is too short after installation, remove it, press firmly onto the hook-and-loop fastener, then reattach it.

If the trim strip is too long after installation, remove it, do not fasten the hook-and-loop tightly, and adjust it to the proper length.

**Tip:** Wipe the attachment surface with a dry cloth to ensure the hook-and-loop fastener adheres firmly.

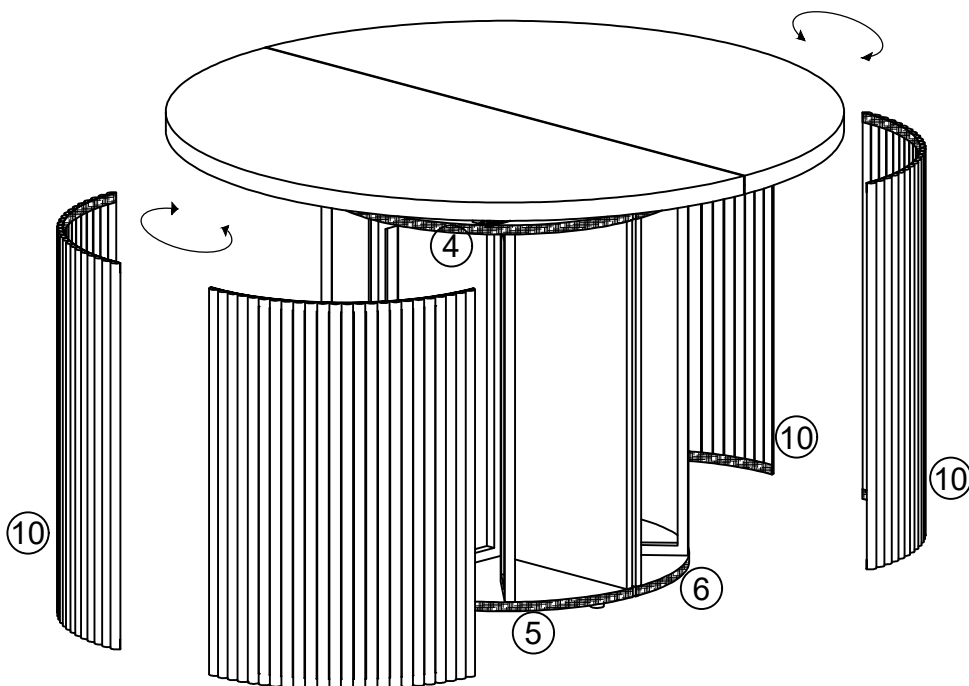

11.



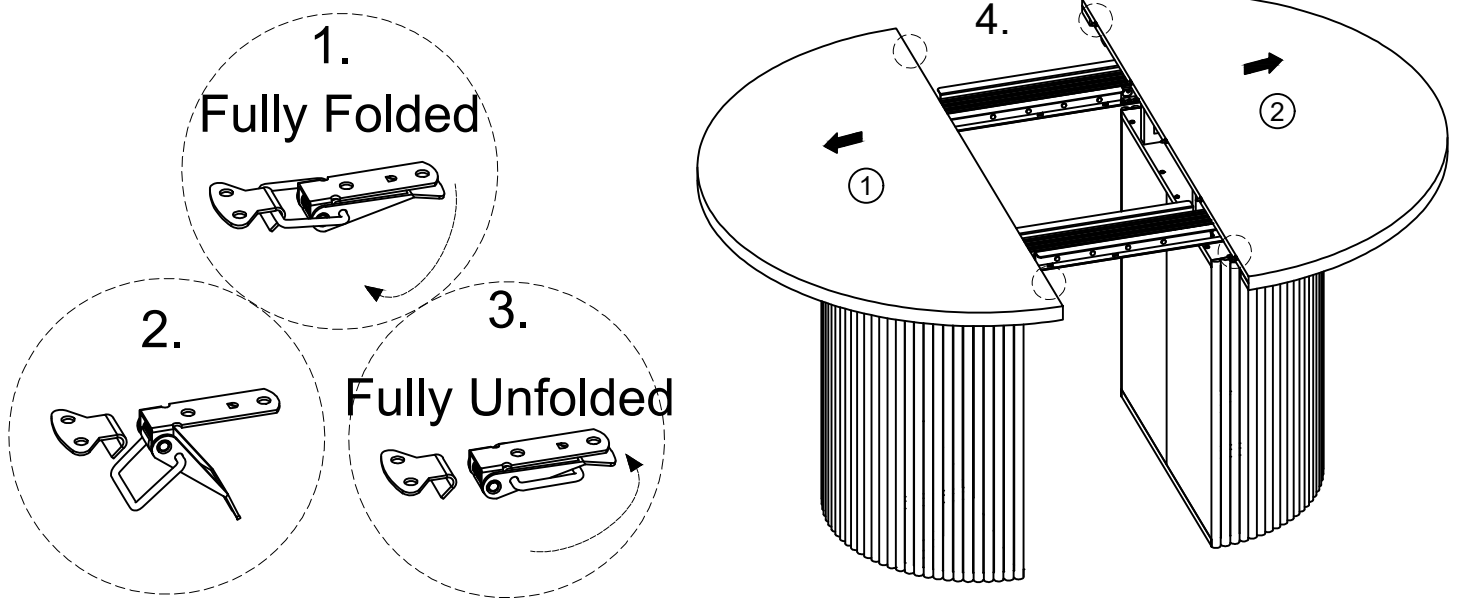

Ensure ALL lock catches underneath the tabletop are UNLOCKED before pulling. Forcing the table to expand while locked will permanently damage the slide rails.



12.



**STOP! Double check:** Are you using the M6x12mm (Part U) screws here? The **Part 13** cannot be assembled with other screws.

O×2PCS	U×4PCS	B×1PC
	 M6×12mm	 M4mm

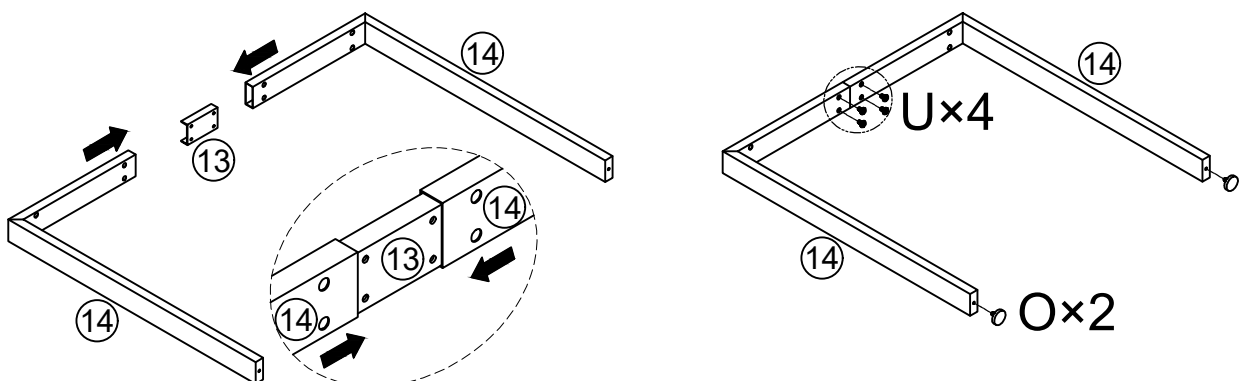

# 13.

N×4PCS

T×1PC



M8×30mm



M5mm



Part 14 is designed to enhance stability when the table is extended.

To fold the table into a round shape, please remove Part 14.

If you feel the table is stable enough when fully extended, you may skip this step.

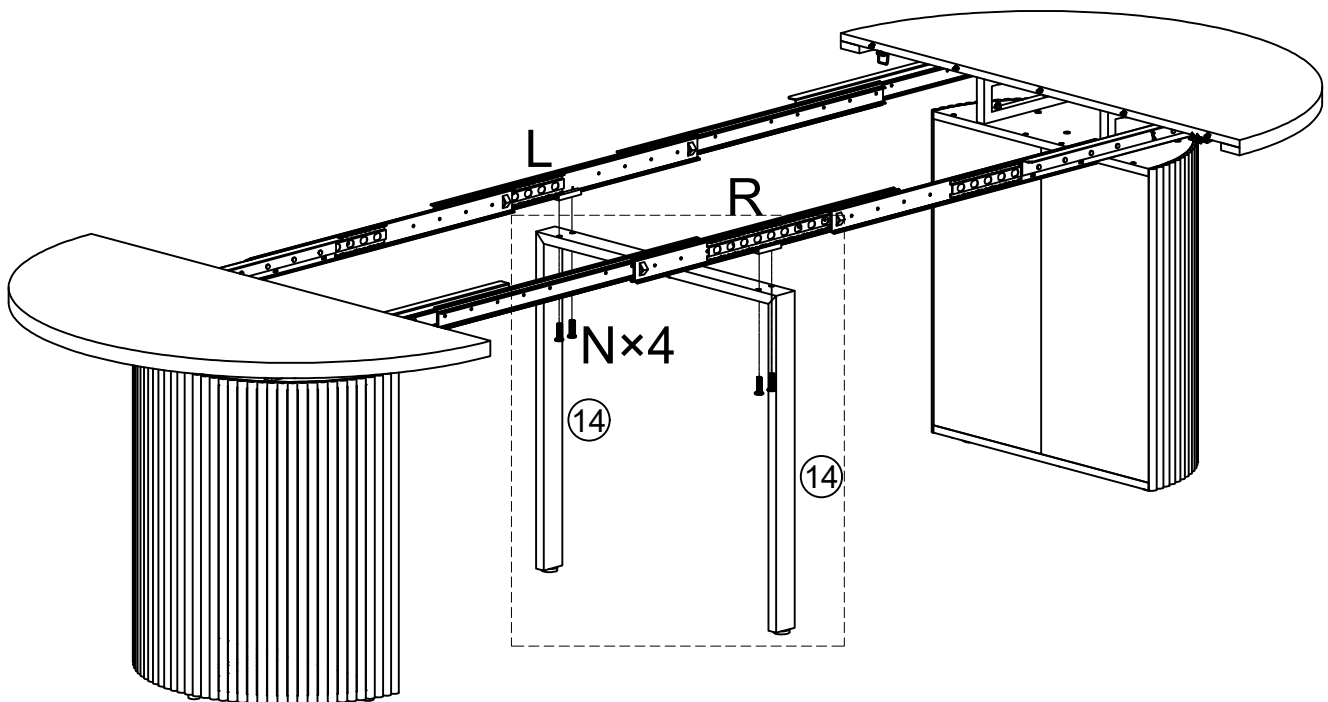

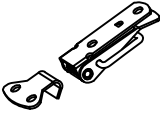
G×32PCS	M×8PCS
 Ø4×12mm	

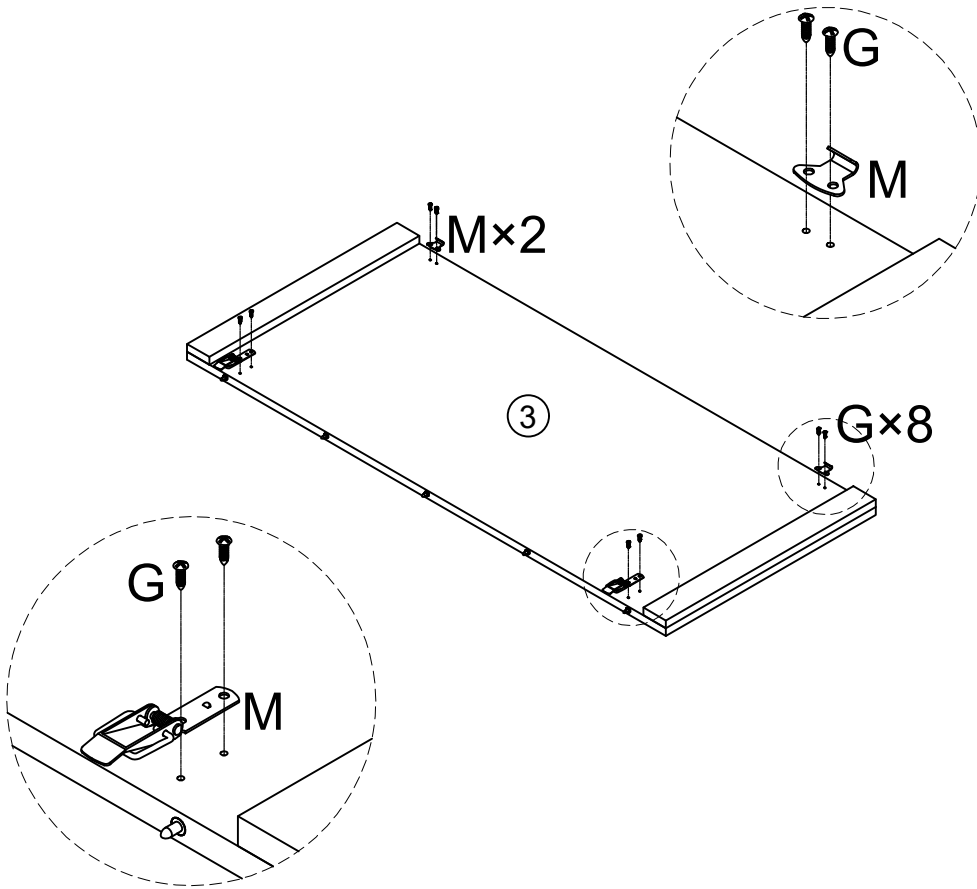

x4

