

ASSEMBLY INSTRUCTION

N606P228396/ N606P228397

N606P228398

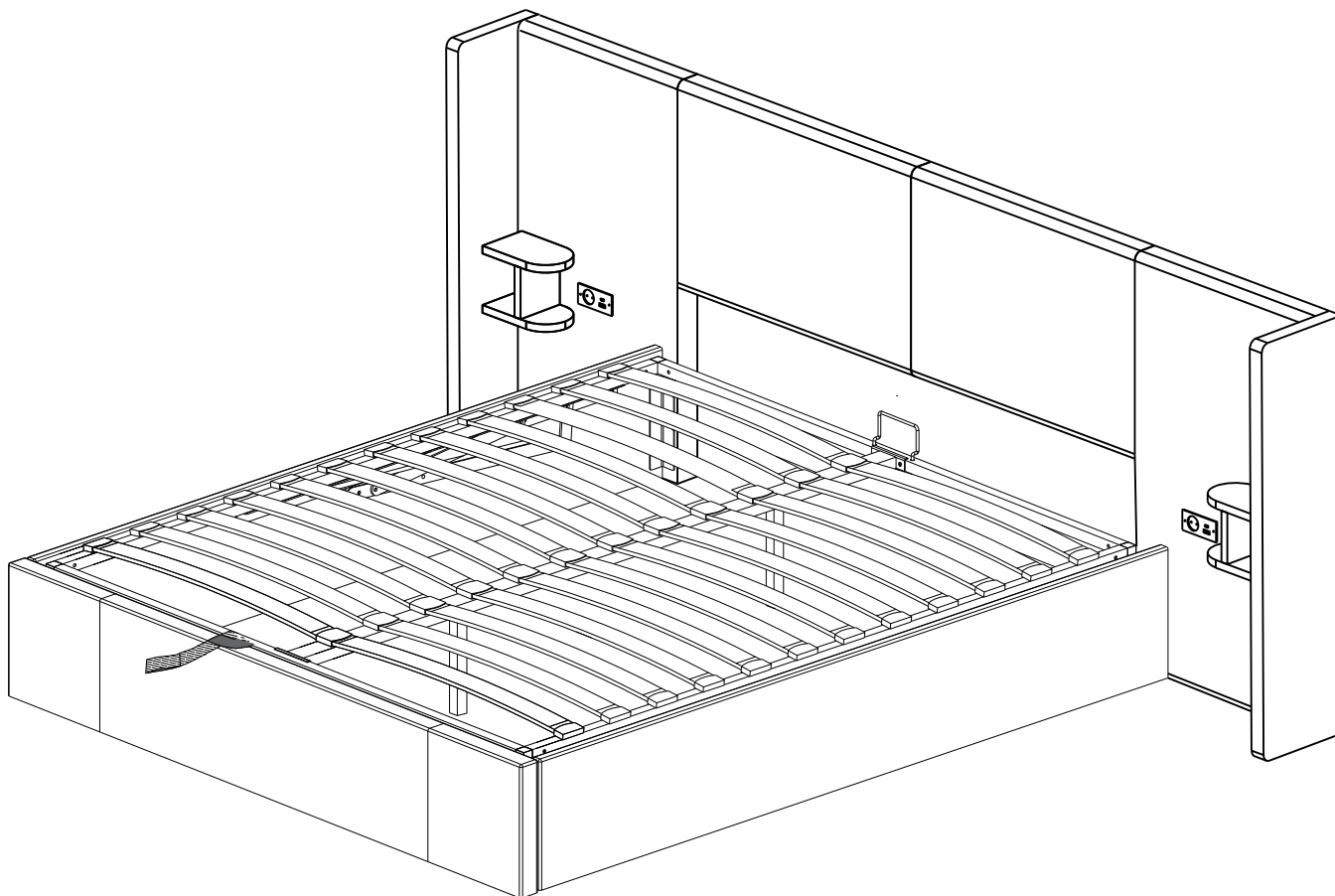

DE: Unser Produkt wird Ihnen in 3 Paketen geliefert. Die Lieferzeiten dieser 3 Pakete können abweichen, bitte haben Sie etwas Geduld und vielen Dank für Ihr Verständnis.

UK: Our product will be delivered to you in 3 packages. The delivery times of these 3 packages may differ, please be patient and thank you for your understanding.

FR: Notre produit vous sera livré en 3 colis. Les délais de livraison de ces 3 colis peuvent différer, soyez patient et merci pour votre compréhension.



ANLEITUNG

ASSEMBLY INSTRUCTION

LE MANUEL D'EMPLOI

TIPPS

1. Dieses Produkt wird für die Lieferung in 2 Pakete aufgeteilt. Sie kommen möglicherweise nicht gleichzeitig an. Bitte warte geduldig .
2. Wir danken Ihnen für den Einkauf! Wir bemühen uns, Ihnen qualitativ hochwertige Produkte zu bieten. In seltenen Fällen, dass Ihr Produkt beschädigt ist, Teile fehlt oder Sie auf Probleme bei der Montage stoßen, wenden Sie sich damit bitte an unseren Kundendienst, wir werden Ihnen die beste Lösung so schnell wie möglich bieten. Um Ihr Problem schnell zu lösen, bitte stellen Sie uns einige Bilder zur Verfügung, die das Produktproblem deutlich widerspiegeln können. Vielen Dank !
3. Setzen Sie die Schrauben in die Löcher ein und ziehen Sie die Schrauben an, aber nicht zu fest, 70 % ~ 80 % ist genug, und ziehen Sie schließlich alle Schrauben an. Wenn einige Schrauben nicht mit den Löchern ausgerichtet sind oder die Montage einiger Teile schwierig ist, stellen Sie bitte den Straffheitsgrad der Schrauben um.
4. Es wird empfohlen, dass 2 Personen das Produkt installieren.

TIPS

1. Please read the instructions fully before assembly. These instructions include important information which could ensure correct assembly. We have been working on providing high quality products for you. However, in the rare instance that your product is defective, missing parts or there are some issues, please don't hesitate to contact our customer service to submit parts requirements, assembly suggestion, or warranty claims, and we will give the best solution as soon as possible. If necessary, we need you to provide some more clear pictures of the issue.
2. Thank you for shopping! We strive to provide you with high quality products. In rare cases that your product is damaged, missing parts or you encounter assembly problems, please contact our customer service with it, we will offer you the best solution as soon as possible. In order to solve your problem quickly, please provide us with some pictures that can clearly reflect the product problem. Thanks very much !
3. Insert the screws in holes and tighten the screws, but not too tight, 70%~80% is ok, finally tighten all the screws. If some issues happened that some screws can not target to the hole or some parts are difficult to install, please adjust the tightness of the screws.
4. 2 people are recommended to finish.

CONSEILS

1. Veuillez lire attentivement les instructions avant le montage. Ces instructions contiennent des informations importantes qui pourraient garantir un montage correct. Nous avons travaillé pour vous fournir des produits de haute qualité. Cependant, dans les rares cas où votre produit est défectueux, s'il manque des pièces ou s'il y a des problèmes, n'hésitez pas à contacter notre service client pour soumettre des exigences de pièces, des suggestions d'assemblage ou des réclamations de garantie, et nous vous donnerons la meilleure solution comme dès que possible. Si nécessaire, nous avons besoin que vous fournissiez des images plus claires du problème.
2. Merci pour vos achats ! Nous nous efforçons de vous fournir des produits de haute qualité. Dans les rares cas où votre produit est endommagé, des pièces manquantes ou que vous rencontrez des problèmes de montage, veuillez contacter notre service client avec celui-ci, nous vous proposerons la meilleure solution le plus vite possible. Afin de résoudre votre problème rapidement, veuillez nous fournir des images qui peuvent clairement refléter le problème du produit. Merci beaucoup !
3. Insérez les vis dans les trous et serrez les vis, mais pas trop serré, 70% ~ 80% est ok, enfin serrez toutes les vis. Si certains problèmes surviennent, certaines vis ne peuvent pas viser le trou ou certaines pièces sont difficiles à installer, veuillez ajuster le serrage des vis.
4. Deux personnes sont recommandées pour le terminer.

English

IMPORTANT FOR GAS LIFT BEDS&MAINTAINANCE

- Please place the mattress on top of the bed frame.
- Please do not pull on the strap handles.
- Please press heavily to release the compressed gas.
- Periodically check all screw & fixings to ensure they are secure.
- When moving your product, carefully lift into place.
- Wipe clean with a slightly damp cloth- please do not use abrasive chemicals or bleach.
- Do NOT allow children to operate the lift mechanism.
- Do NOT allow children near the lift base when operating the mechanism.
- Do NOT stand inside the bed or the internal storage base.
- Do NOT overload the internal storage base.
- DO NOT jump on the product or any of its parts.

Deutsch

WICHTIG FÜR GASLIFT-BETTEN&WARTUNG

- Bitte legen Sie die Matratze oben auf den Bettrahmen.
- Bitte ziehen Sie nicht an den Gurtgriffen.
- Bitte drücken Sie kräftig, um das komprimierte Gas freizusetzen.
- Überprüfen Sie regelmäßig alle Schrauben und Befestigungen, um sicherzustellen, dass sie sicher sind.
- Wenn Sie Ihr Produkt bewegen, heben Sie es vorsichtig an seinen Platz.
- Mit einem leicht feuchten Tuch abwischen - bitte keine scheuernden Chemikalien oder Bleichmittel verwenden.
- Erlauben Sie Kindern NICHT, den Hebemechanismus zu bedienen.
- Lassen Sie Kinder NICHT in die Nähe des Liftsockels, wenn Sie den Mechanismus bedienen.
- Stellen Sie sich NICHT in das Bett oder in die Innenablage.
- Überlasten Sie den internen Liftsockel NICHT.
- Springen Sie NICHT auf das Produkt oder eines seiner Teile.

Français

IMPORTANT POUR LES LITS À RELEVAGE DE GAZ&MAINTENANCE

- Veuillez placer le matelas sur le dessus du cadre de lit.
- Ne tirez pas sur les poignées de la sangle.
- Appuyez fortement pour libérer le gaz comprimé.
- Vérifiez régulièrement que toutes les vis et fixations sont bien en place.
- Lorsque vous déplacez votre produit, soulevez-le avec précaution pour le mettre en place.
- Nettoyez avec un chiffon légèrement humide - n'utilisez pas de produits chimiques abrasifs ou d'eau de Javel.
- Ne laissez pas les enfants utiliser le mécanisme de levage.
- Ne laissez pas les enfants s'approcher de la base de levage lorsqu'ils actionnent le mécanisme.
- Ne vous tenez PAS à l'intérieur du lit ou de la base de stockage interne.
- Ne surchargez pas la base de stockage interne.
- Ne pas sauter sur le produit ou l'une de ses parties.

Italiano

IMPORTANTE PER I LETTI CON SOLLEVAMENTO A GAS E LA MANUTENZIONE

- Posizionare il materasso sopra la struttura del letto.
- Non tirare le maniglie della cinghia.
- Premere con forza per rilasciare il gas compresso.
- Controllare periodicamente tutte le viti e i fissaggi per assicurarsi che siano saldi.
- Quando si sposta il prodotto, sollevarlo con cautela.
- Pulire con un panno leggermente umido, senza usare prodotti chimici abrasivi o candeggina.
- NON permettere ai bambini di azionare il meccanismo di sollevamento.
- NON permettere ai bambini di avvicinarsi alla base di sollevamento quando si aziona il meccanismo.
- NON sostare all'interno del letto o della base di contenimento interna.
- NON sovraccaricare la base di contenimento interna.
- NON saltare sul prodotto o sulle sue parti.

Español

IMPORTANTE PARA LAS CAMAS ELEVADORAS DE GAS&MANTENIMIENTO

- Coloque el colchón sobre el somier.
- No tire de las asas de la correa.
- Presione con fuerza para liberar el gas comprimido.
- Compruebe periódicamente que todos los tornillos y fijaciones estén bien sujetos.
- Al mover el producto, levántelo con cuidado para colocarlo en su sitio.
- Limpie con un paño ligeramente humedecido; no utilice productos químicos abrasivos ni lejía.
- NO permita que los niños accionen el mecanismo de elevación.
- NO permita que los niños se acerquen a la base elevadora cuando accionen el mecanismo.
- NO se ponga de pie dentro de la cama o de la base de almacenamiento interna.
- NO sobrecargue el somier.
- NO salte sobre el producto ni sobre ninguna de sus piezas.

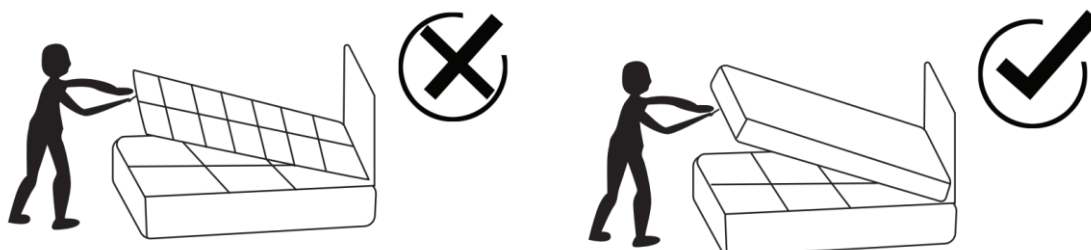

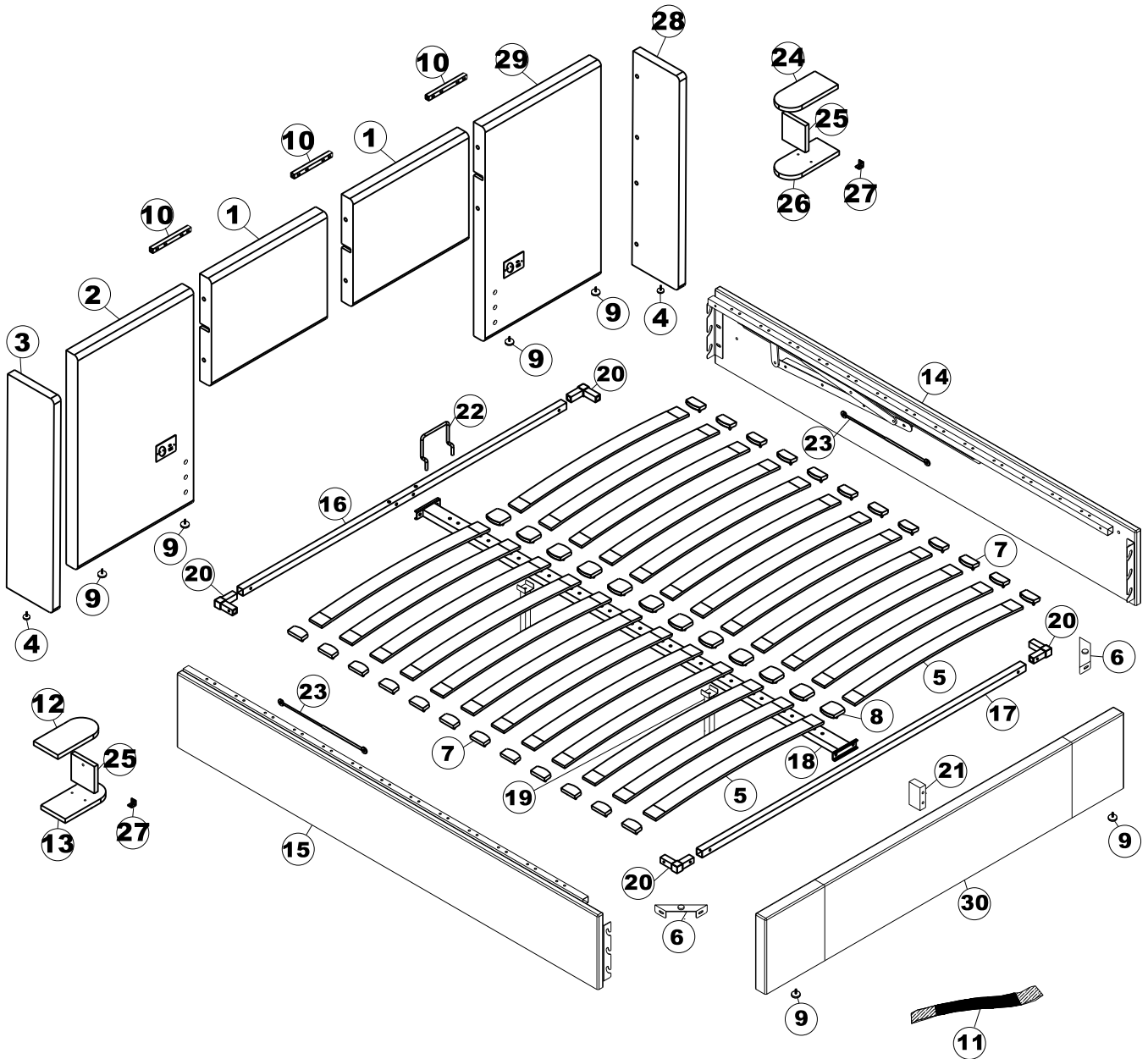

ASSEMBLY INSTRUCTION





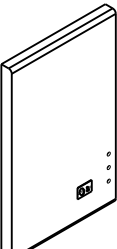
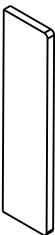
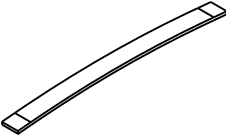
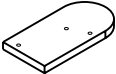
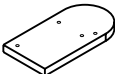
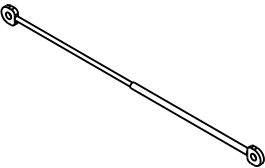
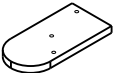

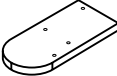
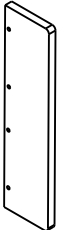
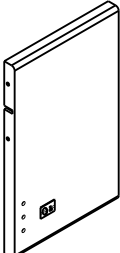



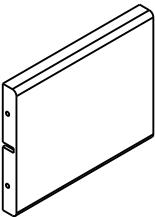

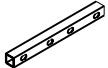

ASSEMBLY DNSTRUCTIONS

Part List-Teileliste-Liste des pièces N606P228396

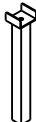
<p>2</p>  <p>1pc</p>	<p>3</p>  <p>1pc</p>	<p>5</p>  <p>24pcs</p>	<p>12</p>  <p>1pc</p>	<p>13</p>  <p>1pc</p>
<p>23</p>  <p>2pcs</p>	<p>24</p>  <p>1pc</p>	<p>25</p>  <p>2pcs</p>	<p>26</p>  <p>1pc</p>	<p>28</p>  <p>1pc</p>
<p>29</p>  <p>1pc</p>				

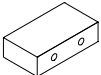
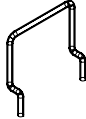
Part List-Teileliste-Liste des pièces N606P228398

<p>1</p>  <p>2pcs</p>	<p>4</p>  <p>2pcs</p>	<p>6</p>  <p>2pcs</p>	<p>7</p>  <p>24pcs</p>	<p>8</p>  <p>12pcs</p>
<p>9</p>  <p>6pcs</p>	<p>10</p>  <p>3pcs</p>	<p>11</p>  <p>1pc</p>	<p>19</p>  <p>2pcs</p>	<p>20</p>  <p>4pcs</p>
<p>21</p>  <p>1pc</p>	<p>22</p>  <p>1pc</p>	<p>27</p>  <p>10pcs</p>		





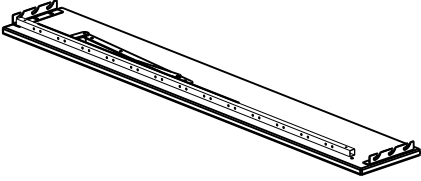
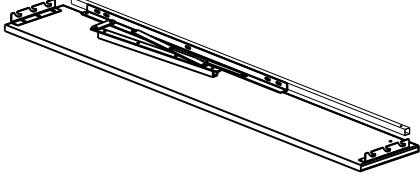
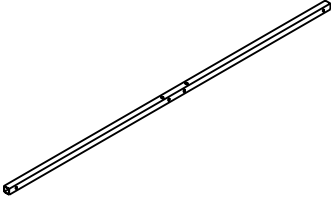
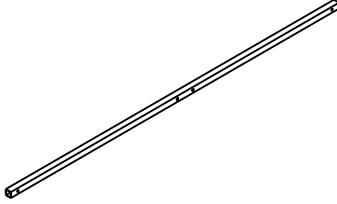
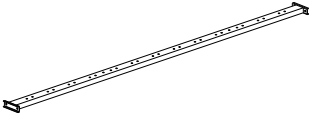
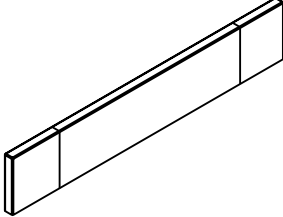





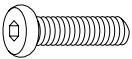
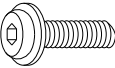

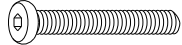
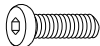
ASSEMBLY INSTRUCTION

Part List-Teileliste-Liste des pièces N606P228397

<p>15</p>  <p>1pc</p>	<p>14</p>  <p>1pc</p>
<p>16</p>  <p>1pc</p>	<p>17</p>  <p>1pc</p>
<p>18</p>  <p>1pc</p>	<p>30</p>  <p>1pc</p>

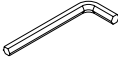
Hardware List-Hardware-Liste-Liste du matériel

N606P228398

<p>A</p>  <p>M8x30 26pcs</p>	<p>B</p>  <p>M8x25 12pcs</p>	<p>C</p>  <p>M6x10 12pcs</p>	<p>D</p>  <p>M6x80 2pcs</p>
<p>E</p>  <p>M6x20 8pcs</p>	<p>F</p>  <p>M6x25 4pcs</p>	<p>G</p>  <p>M8 4pcs</p>	<p>H</p>  <p>Ø6x35 4pcs</p>
<p>N</p>  <p>M8x35 2pcs</p>	<p>M</p>  <p>M6x15 4pcs</p>	<p>I</p>  <p>Spanner 1pc</p>	<p>J</p>  <p>M5 allen key 1pc</p>
<p>K</p>  <p>M4 allen key 1pc</p>	<p>L</p>  <p>M3 allen key 1pc</p>	<p>O</p>  <p>4pcs</p>	

ASSEMBLY INSTRUCTION

Step1:

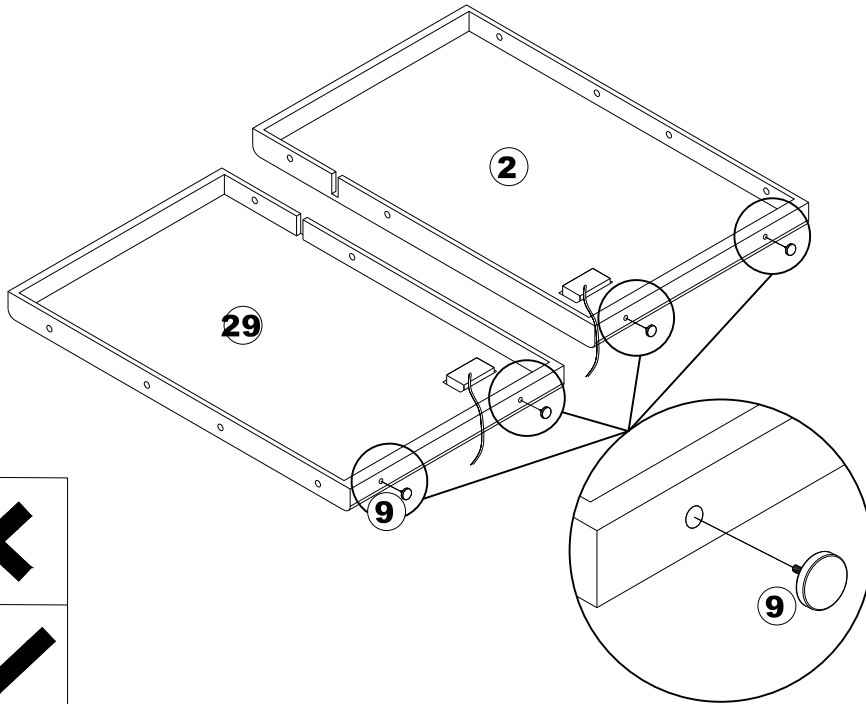

Step2:

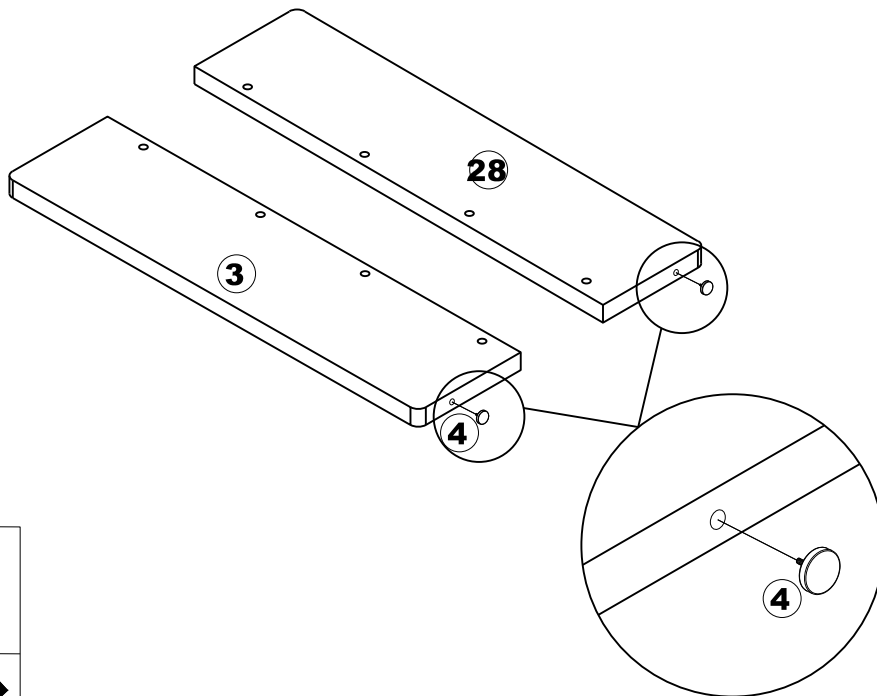

ASSEMBLY INSTRUCTION

Step3:

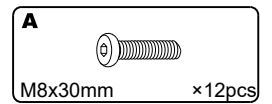
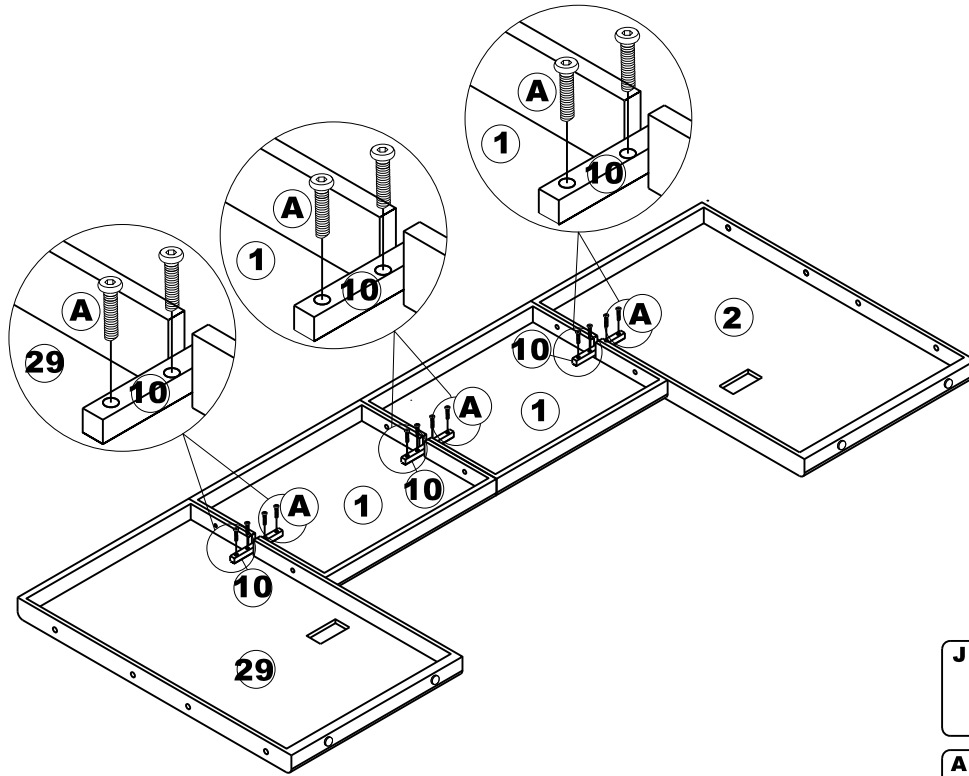

Step4:

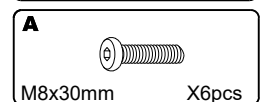
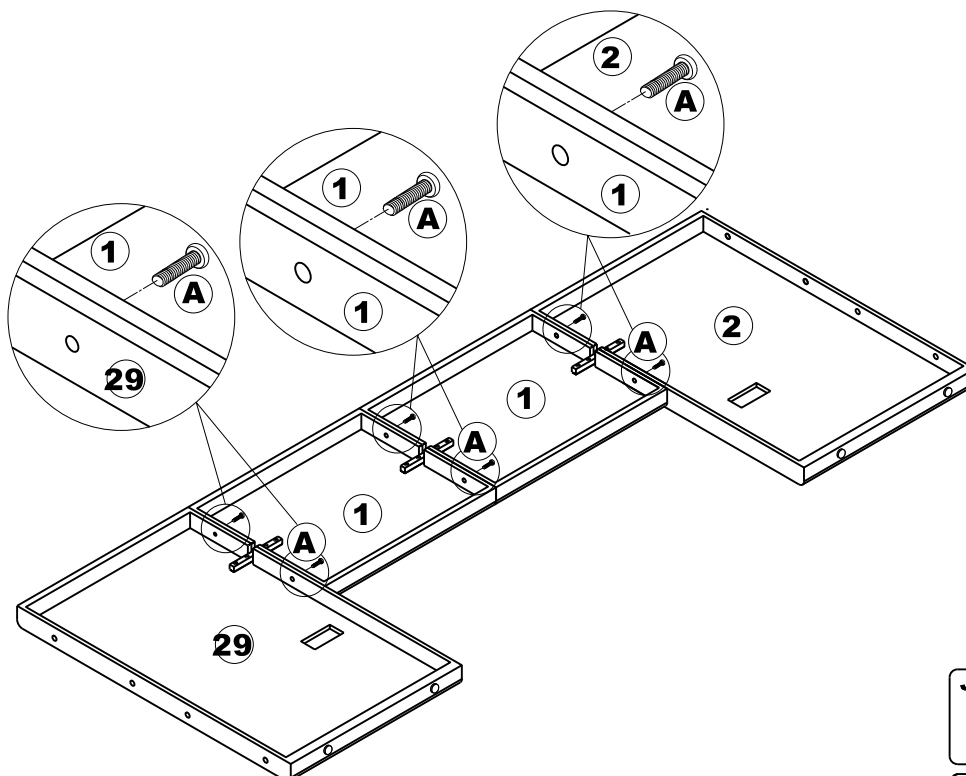

ASSEMBLY INSTRUCTION

Step5:

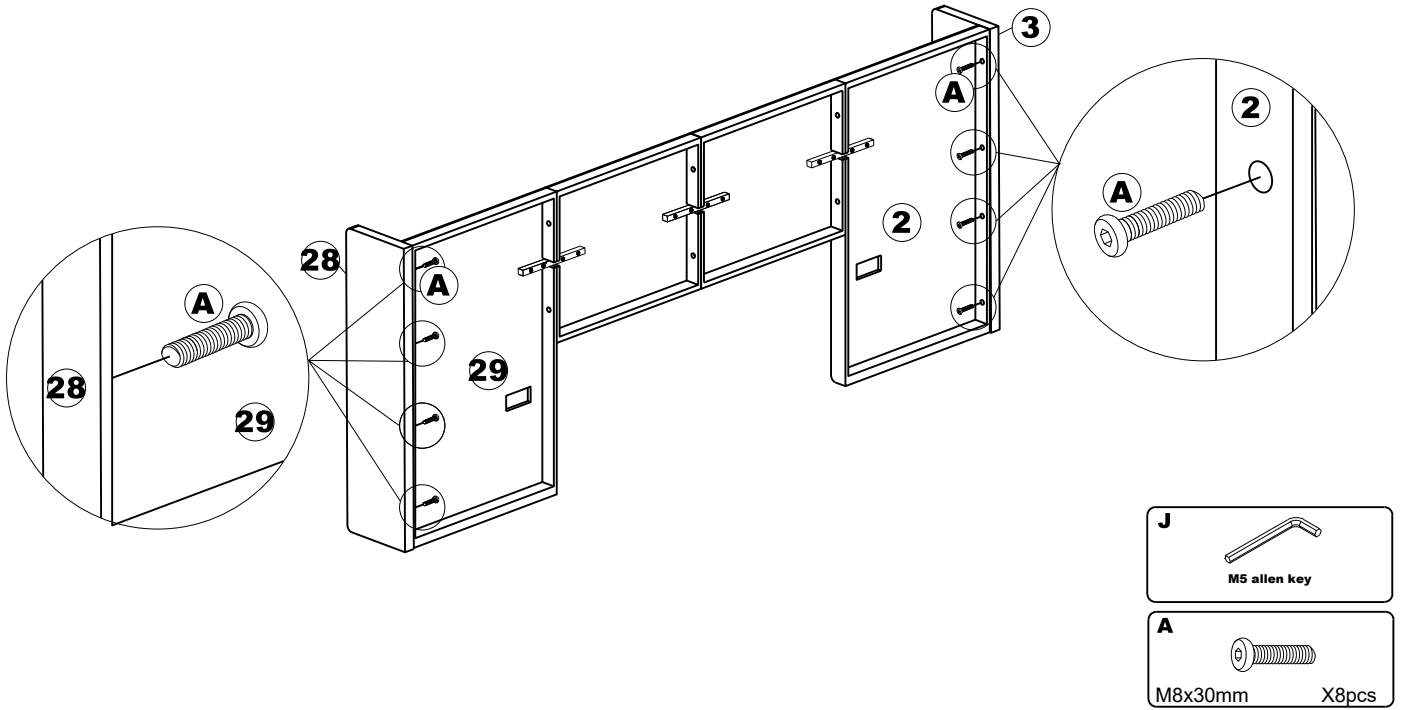

Step6:

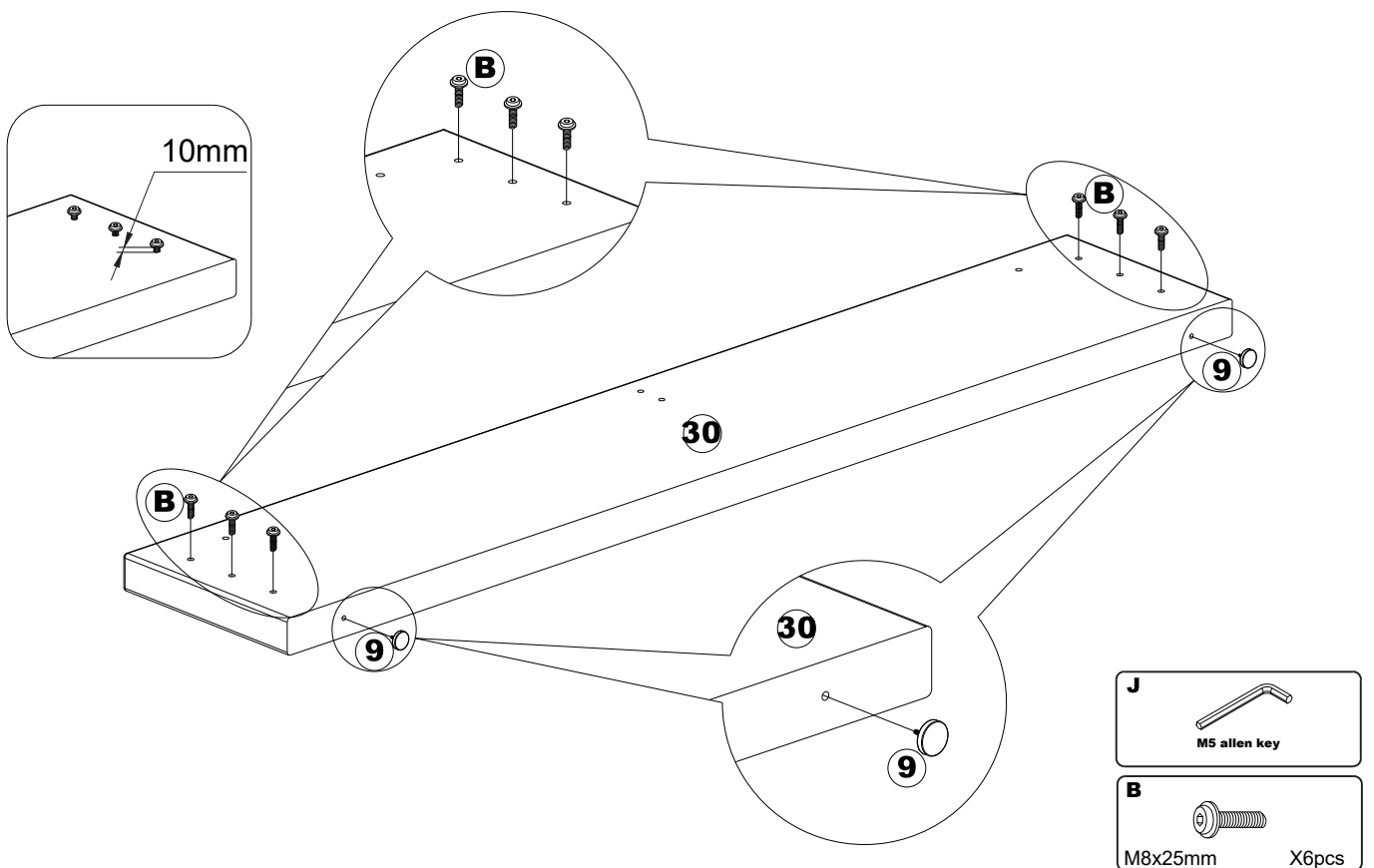

ASSEMBLY INSTRUCTION

Step7:

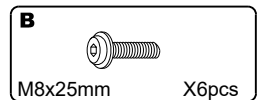
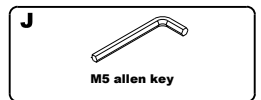
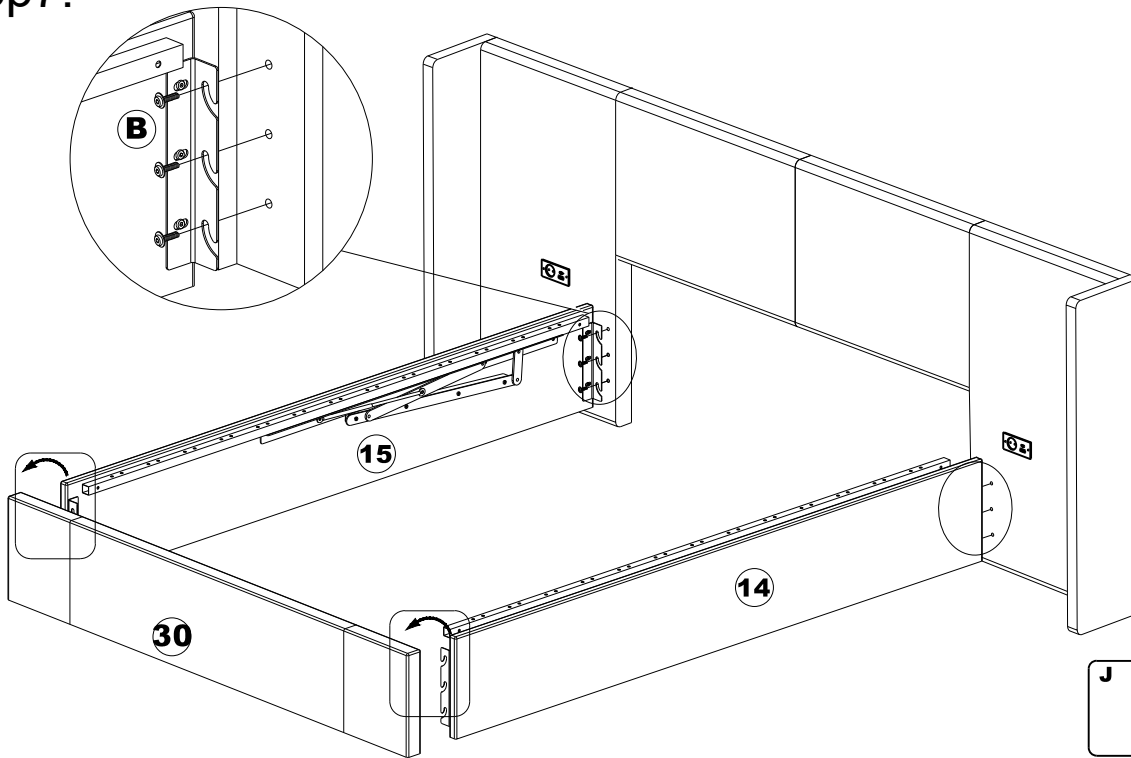

Step8:

Please pay attention to the positions of the screws on both the left and right sides to keep them consistent.

Bitte beachten Sie die Positionen der Schrauben auf der linken und rechten Seite, um sicherzustellen, dass sie übereinstimmen.

Veuillez attentionner aux positions des vis des côtés gauche et droit pour les maintenir identiques.

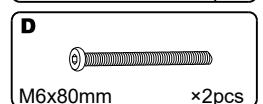
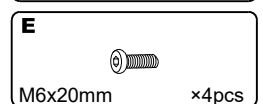
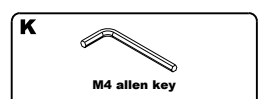
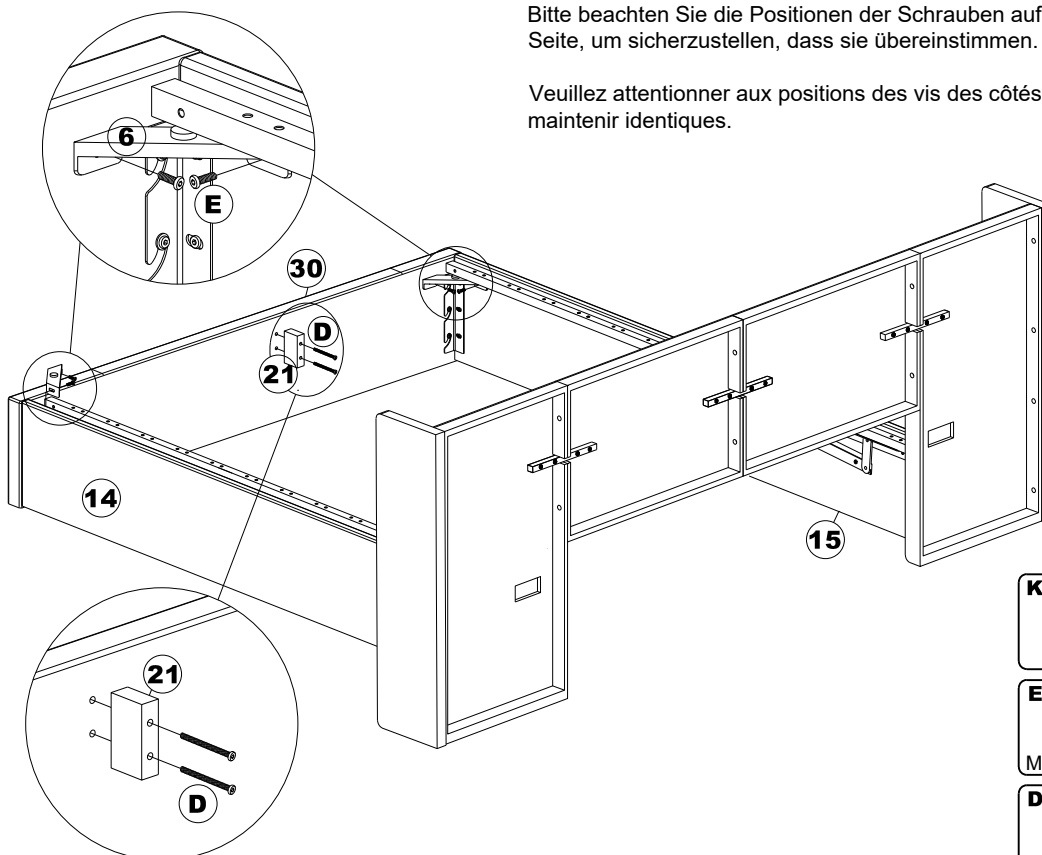

ASSEMBLY INSTRUCTION

Step9:

a:

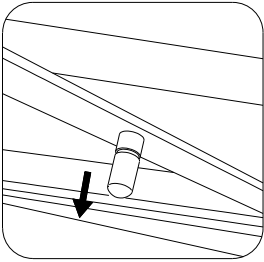

b:

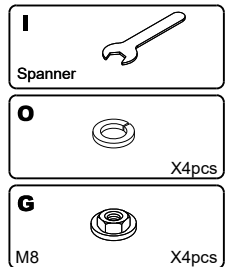
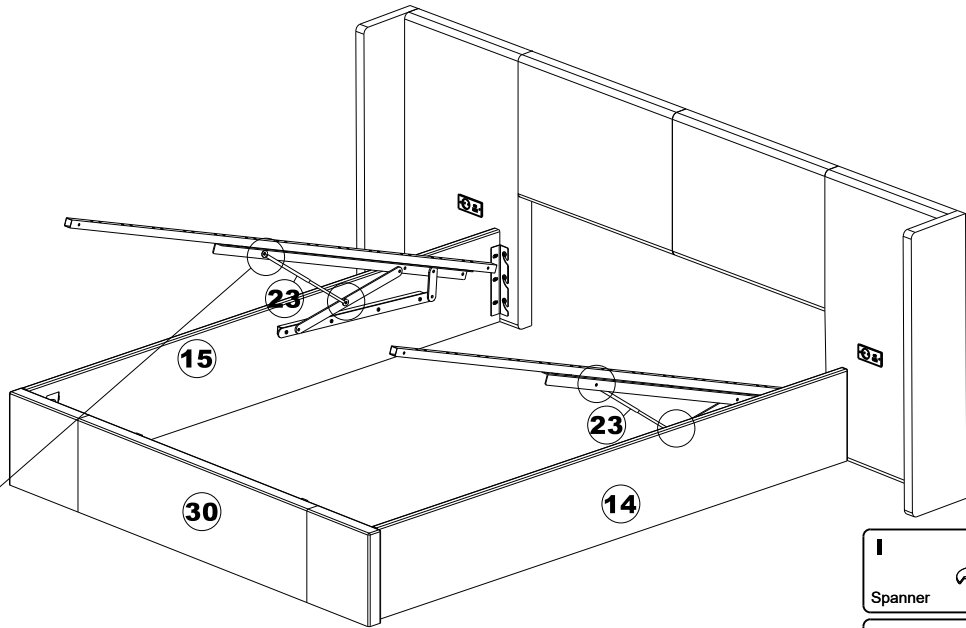
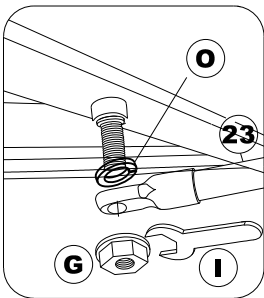

Step10:

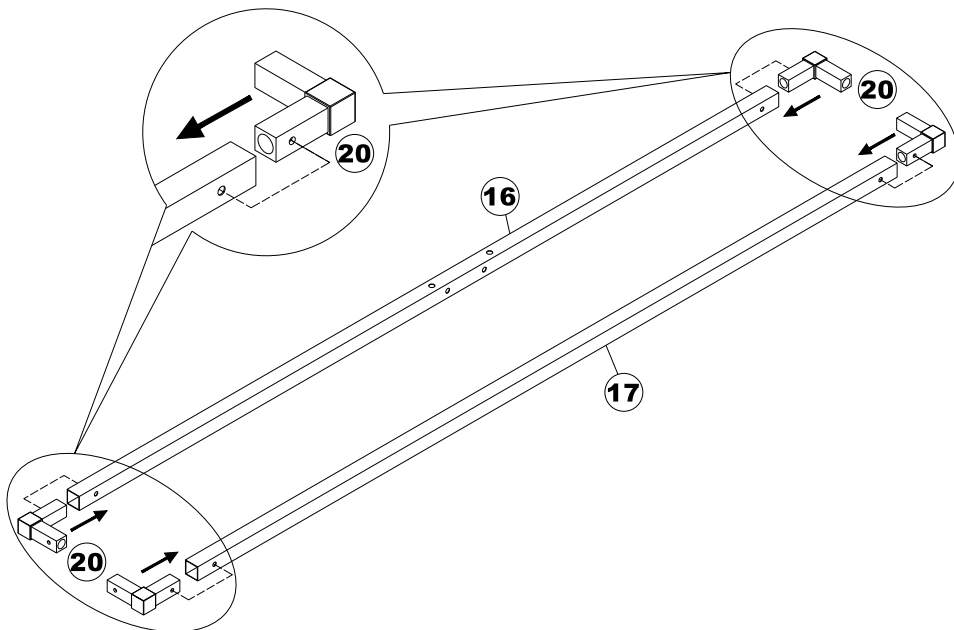

Step11:

Bitte beachten Sie die Schraubverbindungen an Bauteil 14 und 15 und stellen Sie sicher, dass alle Schrauben fest angezogen sind, bevor Sie das Gerät verwenden.

Please note the screw components of parts No.14 and 15, and ensure all screws are fully tightened before use

Veillez porter une attention particulière aux éléments de vis des composants n°14 et 15, et vérifier que toutes les vis sont correctement serrées avant utilisation

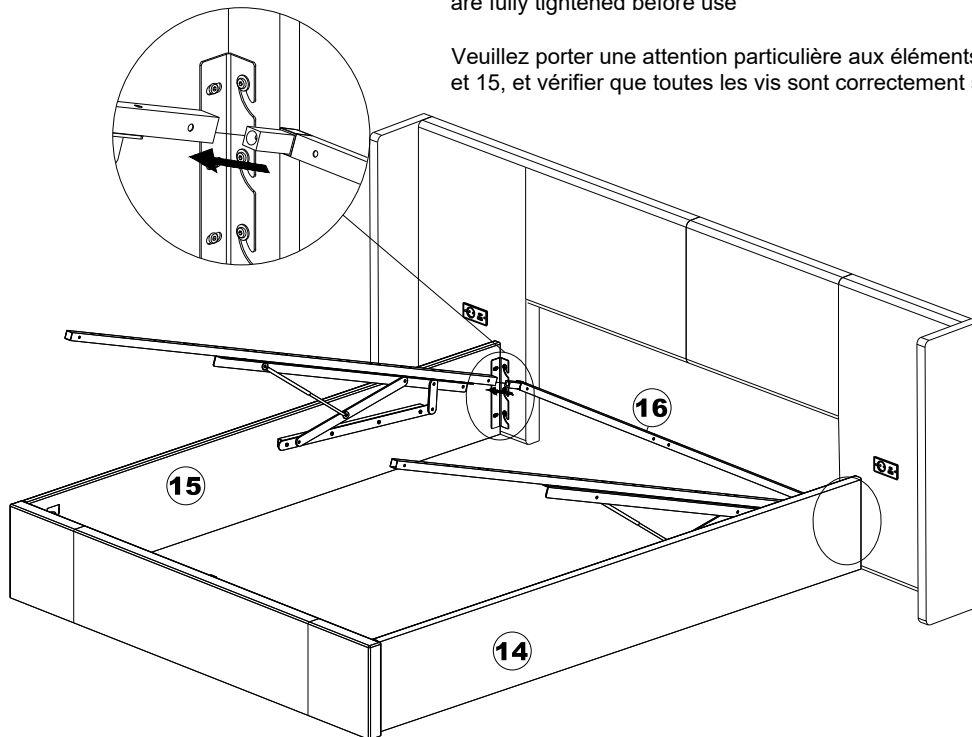

Step12:

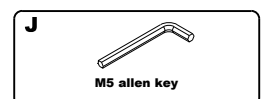
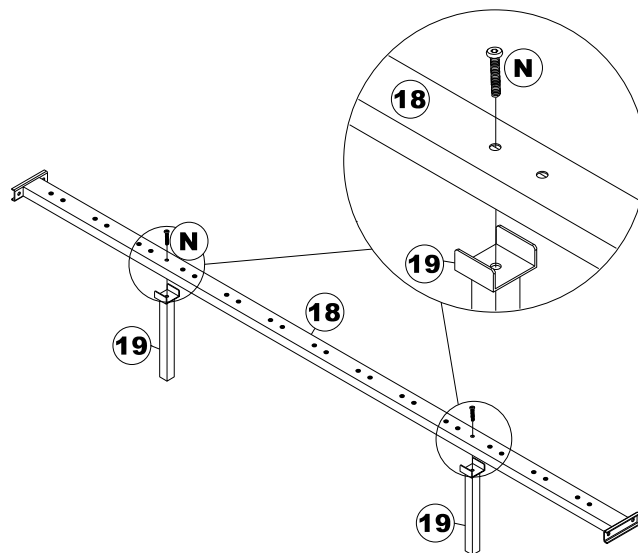

M5 allen key

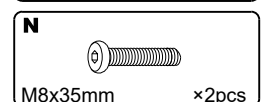

M8x35mm

×2pcs

ASSEMBLY INSTRUCTION

Step13:

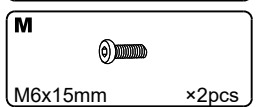
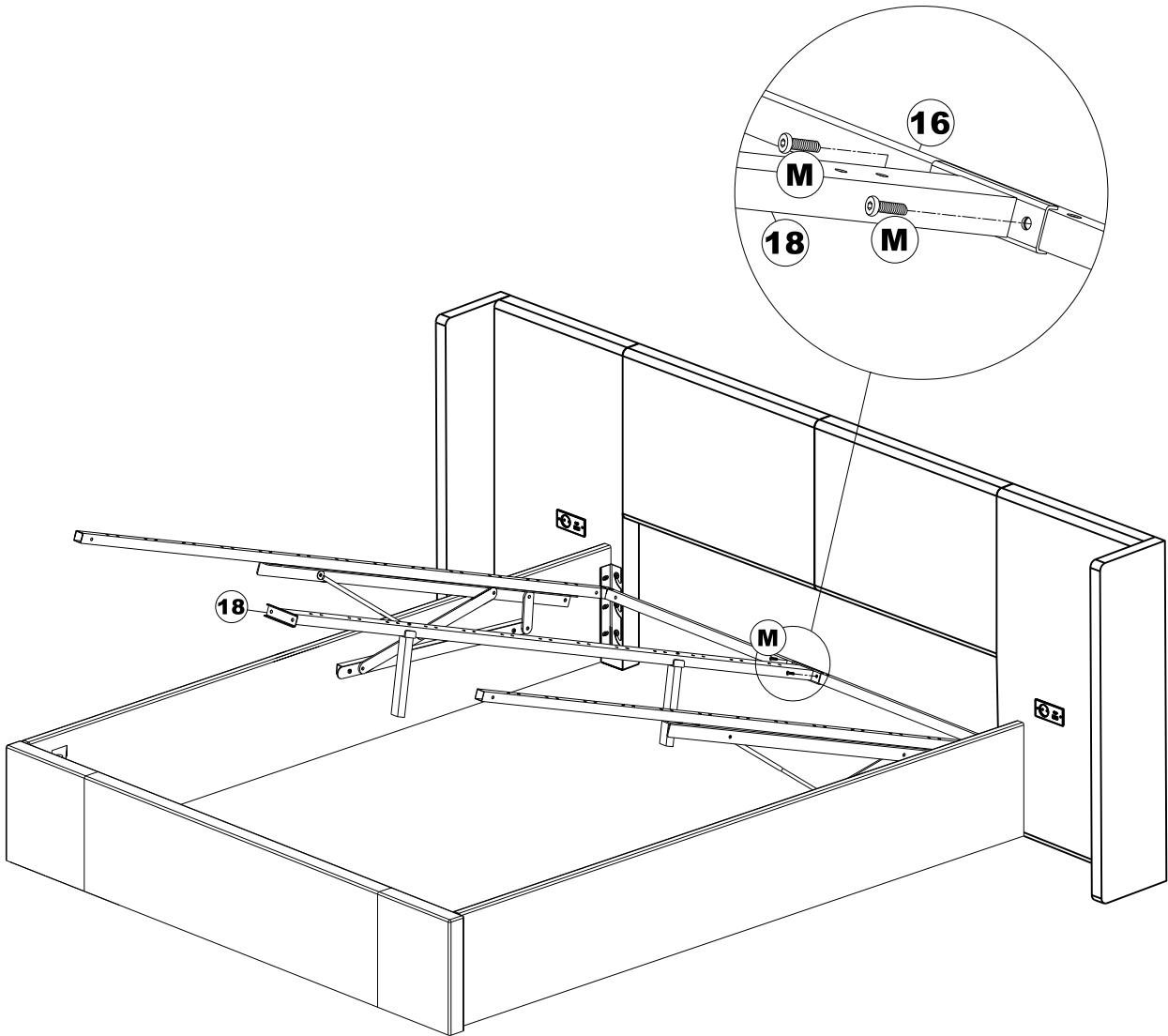

ASSEMBLY INSTRUCTION

Step14:

First press the spring buckle of part 20, and then push it in
Drücken Sie zuerst die Federschnalle von Teil 20 und schieben Sie sie dann hinein.

Appuyez d'abord sur l'anneau à ressort de la pièce n°20 et poussez-le à l'intérieur.

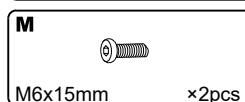
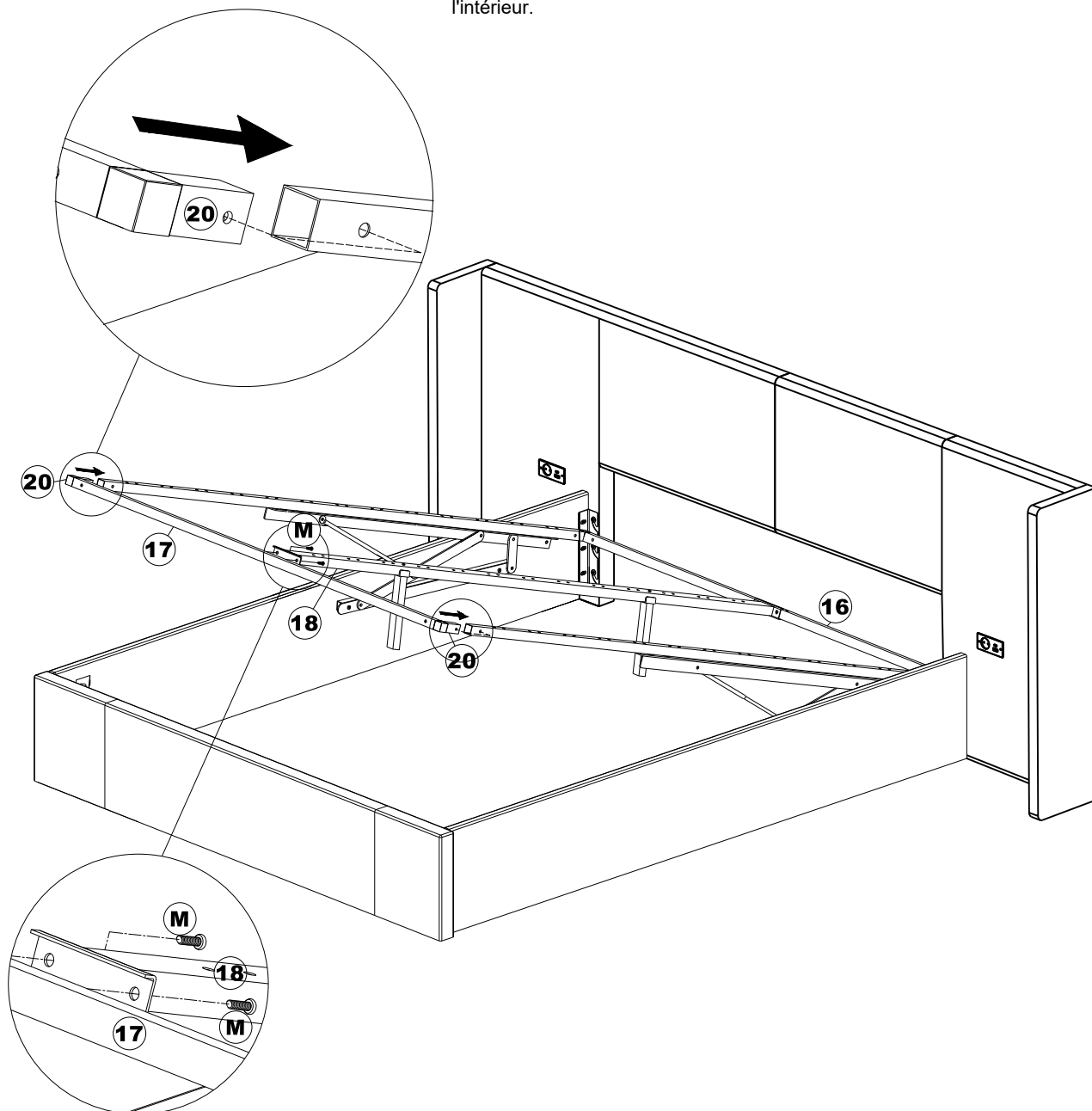

ASSEMBLY INSTRUCTION

Step 15:

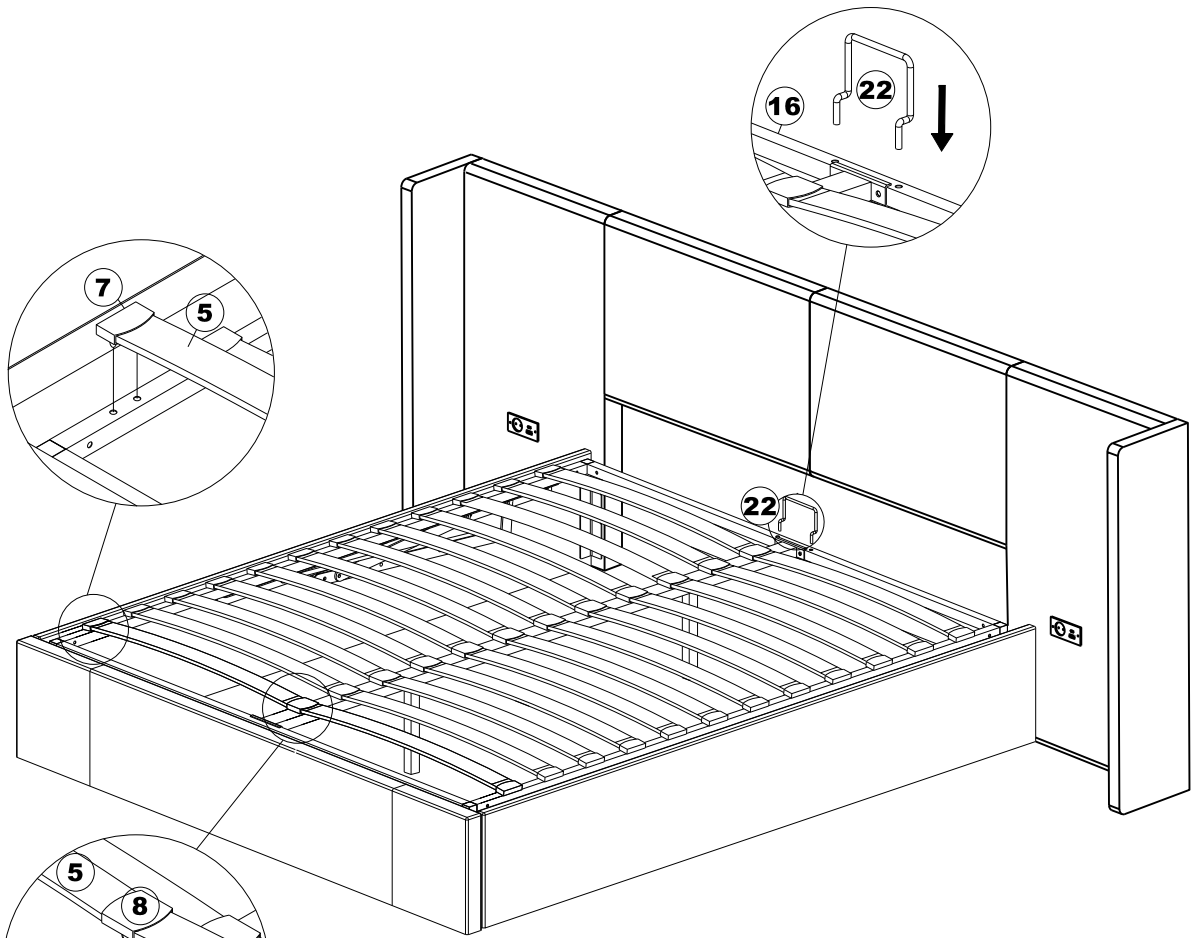
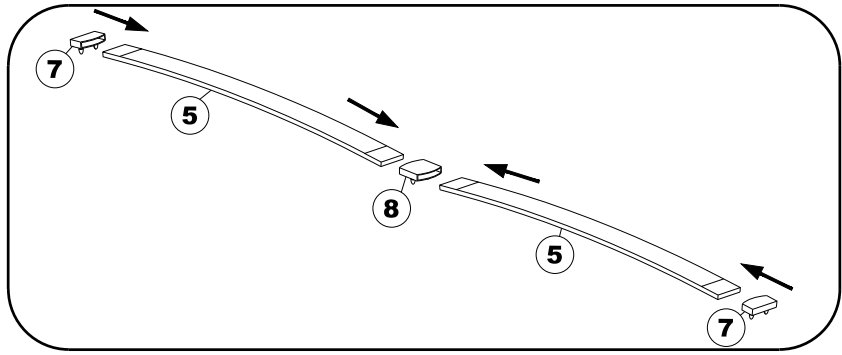

Step16:

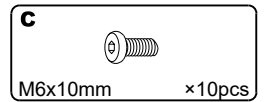
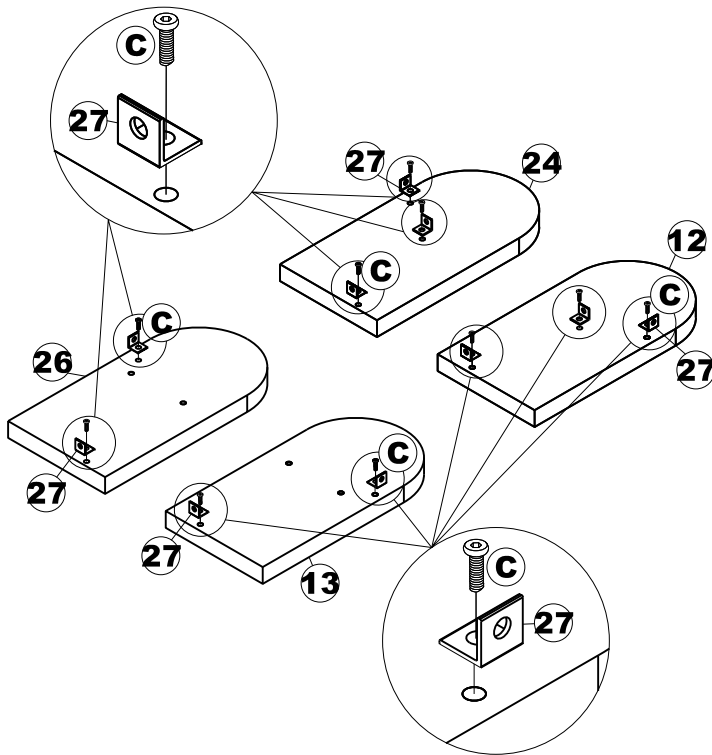

Step17:

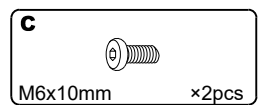
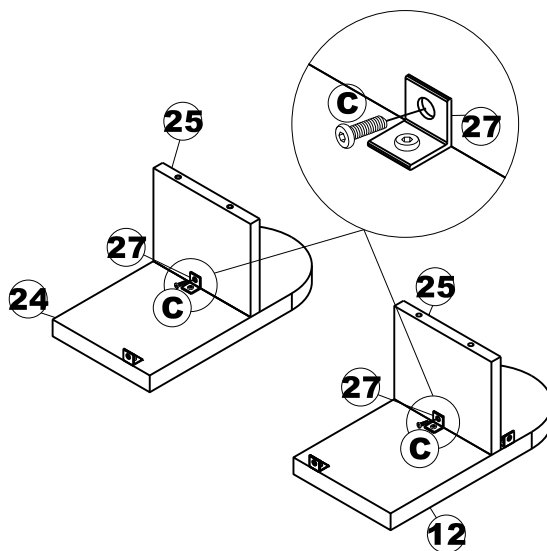

Step18:

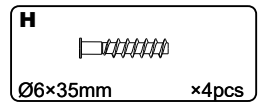
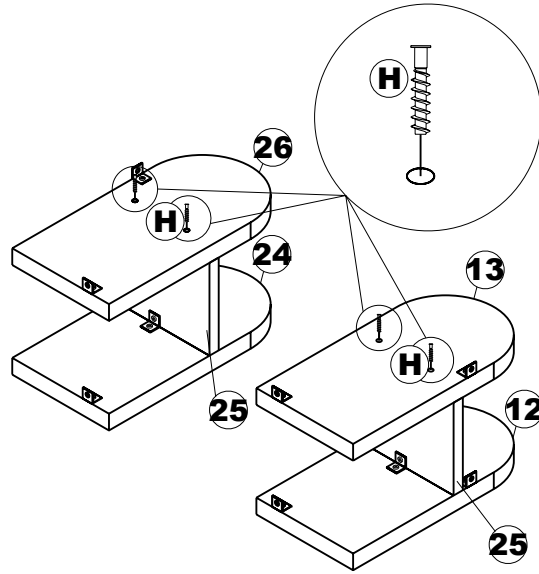

Step19:

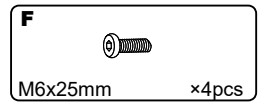
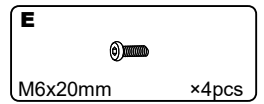
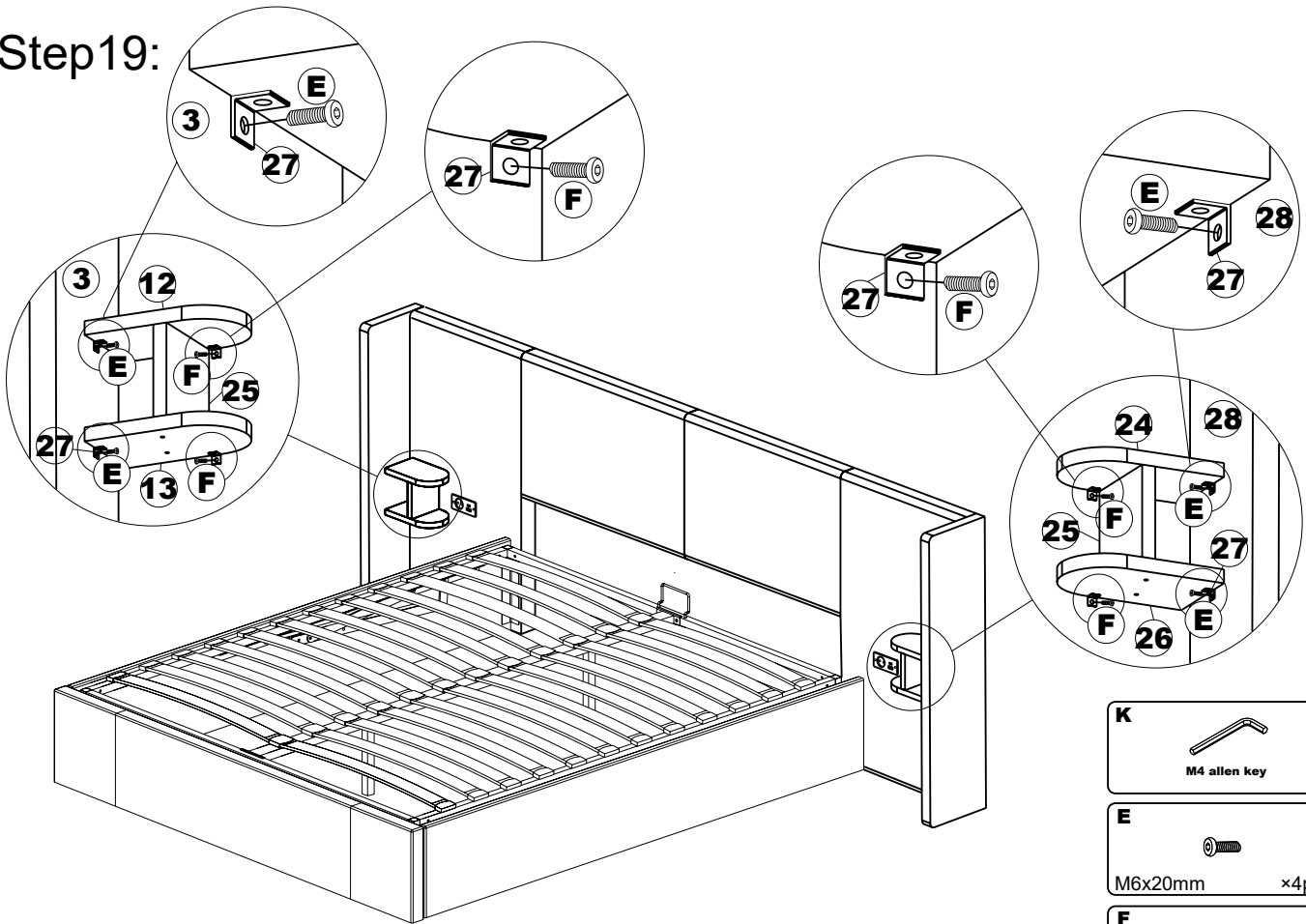

Certificate of Conformity

No.: LP24060215C02-02

The following products have been tested by us with the listed standards and found in compliance with the council UK EMC Regulations (SI 2016/1091) . It is demonstrative for the compliance with this EMC Directive.

Applicant : Dongguan Yali Electric Appliance Co.,Ltd
Address : 8 / F, Building 9, No. 6, Yuyuan 4th Road, Yuyuan Industrial Zone, Huangjiang Town, Dongguan City, Guangdong Province
Product : Strip power supply
Model No. : YL-SKBS-801, YL-SKBS-802, YL-SKBS-803, YL-SKBS-805, YL-SKBS-806, YL-SKBS-807, YL-SKBS-808, YL-SKBS-809, YL-SKBS-801A, YL-SKBS-802A, YL-SKBS-803A, YL-SKBS-805A, YL-SKBS-806A, YL-SKBS-807A, YL-SKBS-808A, YL-SKBS-809A
Trade Name : N/A
Test Standards : BS EN 55032:2015+A11:2020+A1:2020
BS EN IEC 61000-3-2:2019+A1:2021
BS EN 61000-3-3:2013+A1:2019
BS EN 55035:2017+A11:2020



The UKCA mark may be used, if all relevant UK Legislations and the UK Declaration of Conformity has been completed.

Manager: Frank Shen
Date: October 31, 2024

Dongguan Lepont Testing Service Co., Ltd.

Tel.:86-769-83086888 Fax.:86-769-83096886

Room 102, Building 11, No.7, Houjie Science And Technology Avenue, Houjie, Dongguan, Guangdong, China

The statement is based on a single evaluation of one sample of above mentioned products. It does not imply an assessment of the whole production and does not permit the use of the test lab's logo.

Importer	COMHARBOR LIMITED
Add	Unit C, Swift Point, Cosford Lane, Rugby, CV21 1PY,GB
Emai/URL	harborcomhar@gmail.com
Manufacture	Dongguan Yali Electric Appliance Co.,Ltd
Add	8 / F, Building 9, No. 6, Yuyuan 4th Road, Yuyuan Industrial Zone,Huangjiang Town, Dongguan City, Guangdong Province
Emai/URL	1148294675@qq.com
Model	YL-SKBS-801A
Made in	Made in China
	<p>COMHARBOR LIMITED</p> <p>Unit C, Swift Point, Cosford Lane, Rugby, CV21 1PY,GB</p> <p>harborcomhar@gmail.com</p>  