

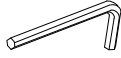

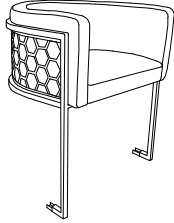

# ASSEMBLY INSTRUCTIONS FOR ITEM NO:SC030-037

HARDWARE LIST					PARTS LIST			
NO.	DESCRIPTION	SKETCH	SIZE	QTY	NO.	DESCRIPTION	SKETCH	QTY
Ⓐ	Allen Key		4MM	1PC	①	Frame		1PC
Ⓑ	Short Bolt		M6*15	6PCS				
Ⓒ	Long Bolt		M6*30	1PCS	②	Support Rod		1PC
Ⓓ	Spring Shim		Ø6	7PCS				
Ⓔ	Washer		Ø13*Ø6	7PCS	③	Base Loop		1PC

## STEP 1

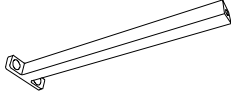

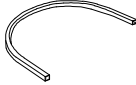
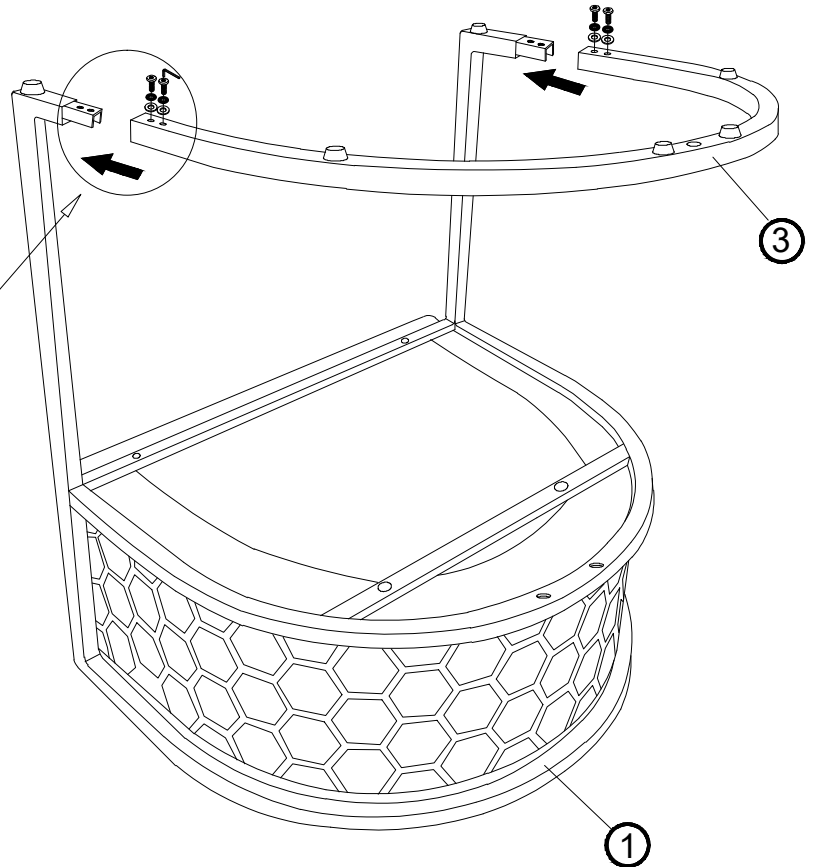
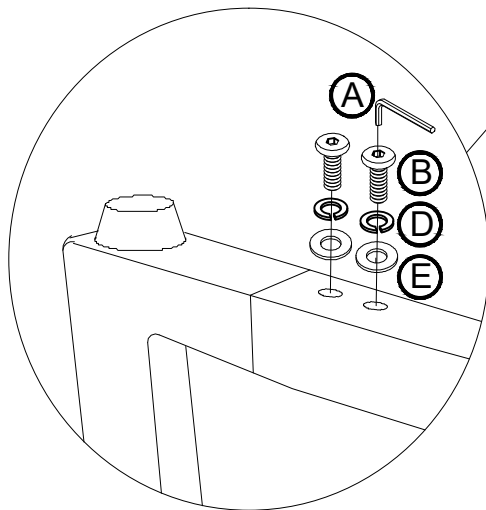
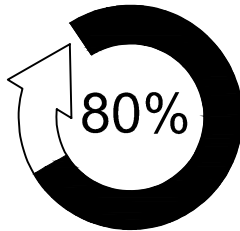
# ASSEMBLY INSTRUCTIONS FOR ITEM NO:SC030-037

STEP 2

Adjustable

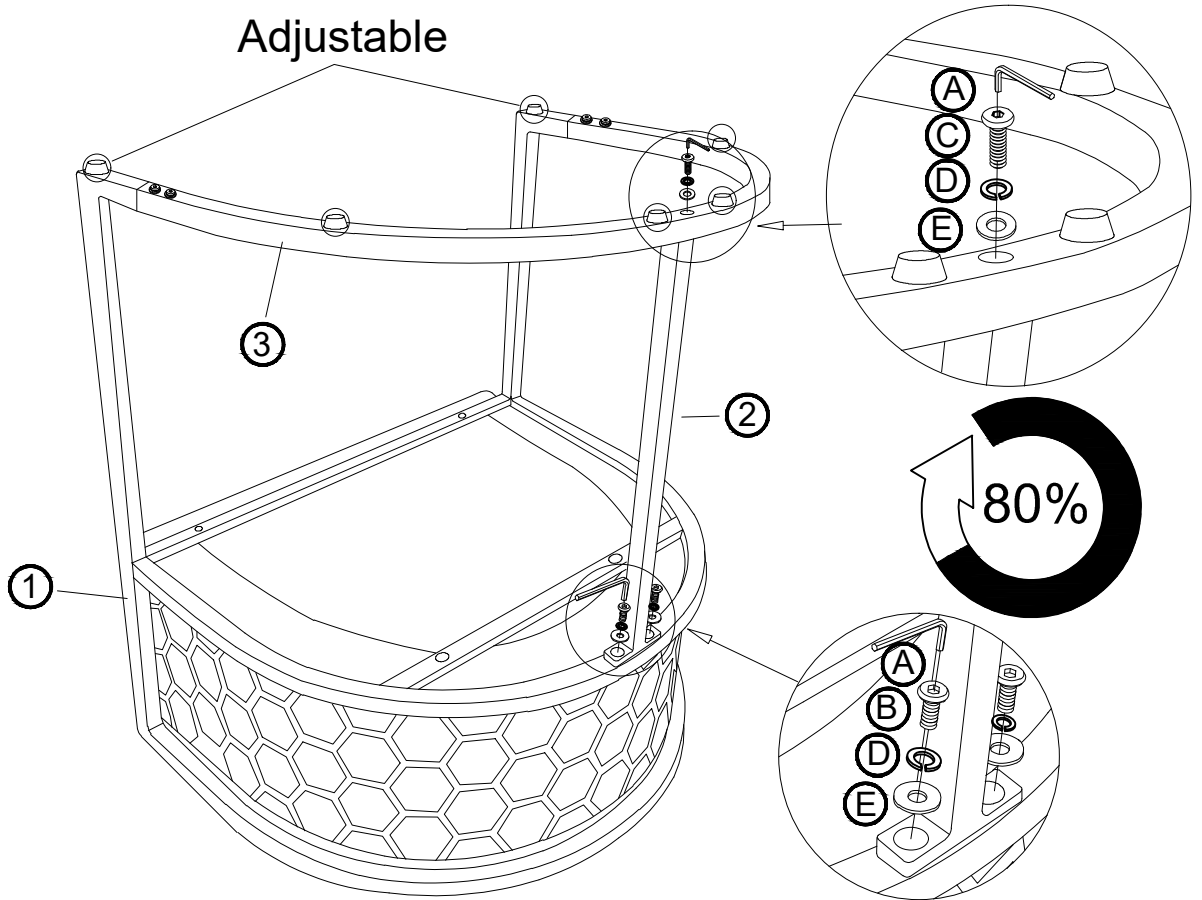

STEP 3

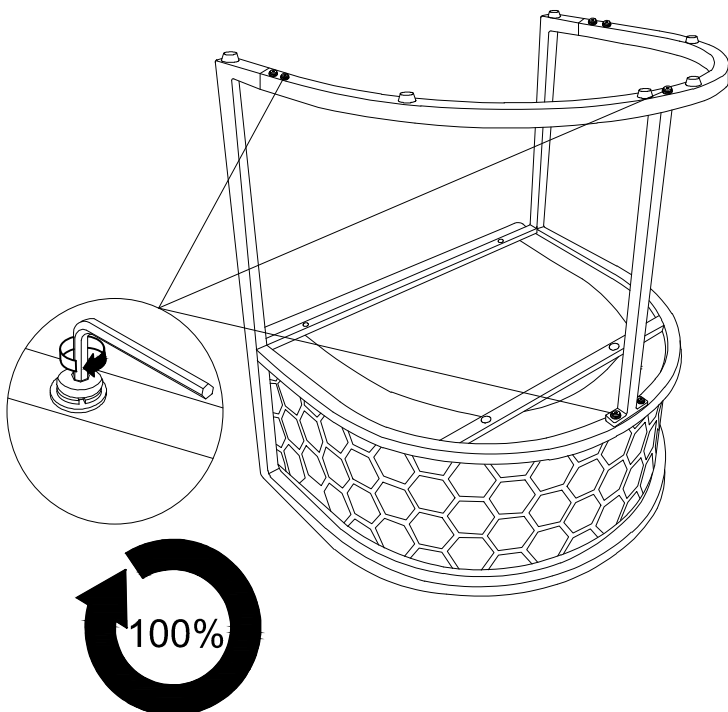

STEP 4

