

# ASSEMBLY INSTRUCTIONS

---

60" Wide L Desk

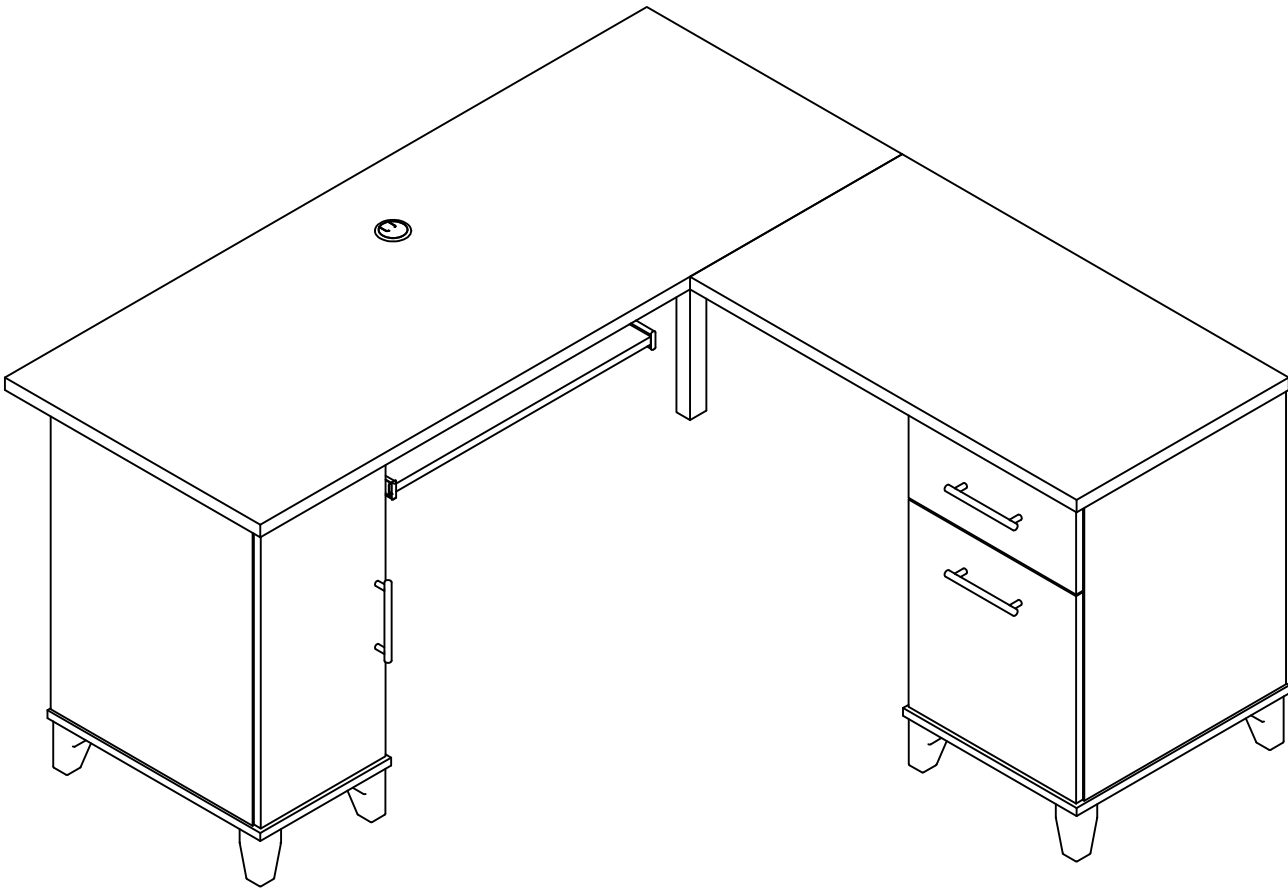

# IMPORTANT SAFETY INFORMATION



## WARNING

This product is designed and intended for use with computer, fax, and printer equipment only. Improper loading with television or other heavy equipment could cause instability, tip over, and/or serious injury.

Este producto esta diseñado solamente para el uso con computadores, faxes, e impresoras. Inapropiado uso al poner televisores u otro equipo pesado puede causar inestabilidad, rodamiento, y/o herida (golpes) serios.

Ce produit est uniquement conçu pour une utilisation avec un ordinateur, un télécopieur, ou une imprimante. Un chargement incorrect avec une télévision ou autre matériel lourd peut le rendre instable ou le renverser, et peut vous causer des endommagements sérieux.



## WARNING

Do not move unit when loaded. Doing so could cause instability, product collapse, tip over, and/or serious injury.

No mueva la unidad cuando esté cargada. Hacerlo puede causar inestabilidad, que el producto se derrumbe, que se la caiga encima y/o heridas (golpes) serias.

Ne pas déplacer l'unité lorsqu'elle est chargée. Faire ainsi peut causer l'instabilité, l'effondrement ou le renversement du meuble et/ou des endommagements sérieux.

# EXPLODED VIEW

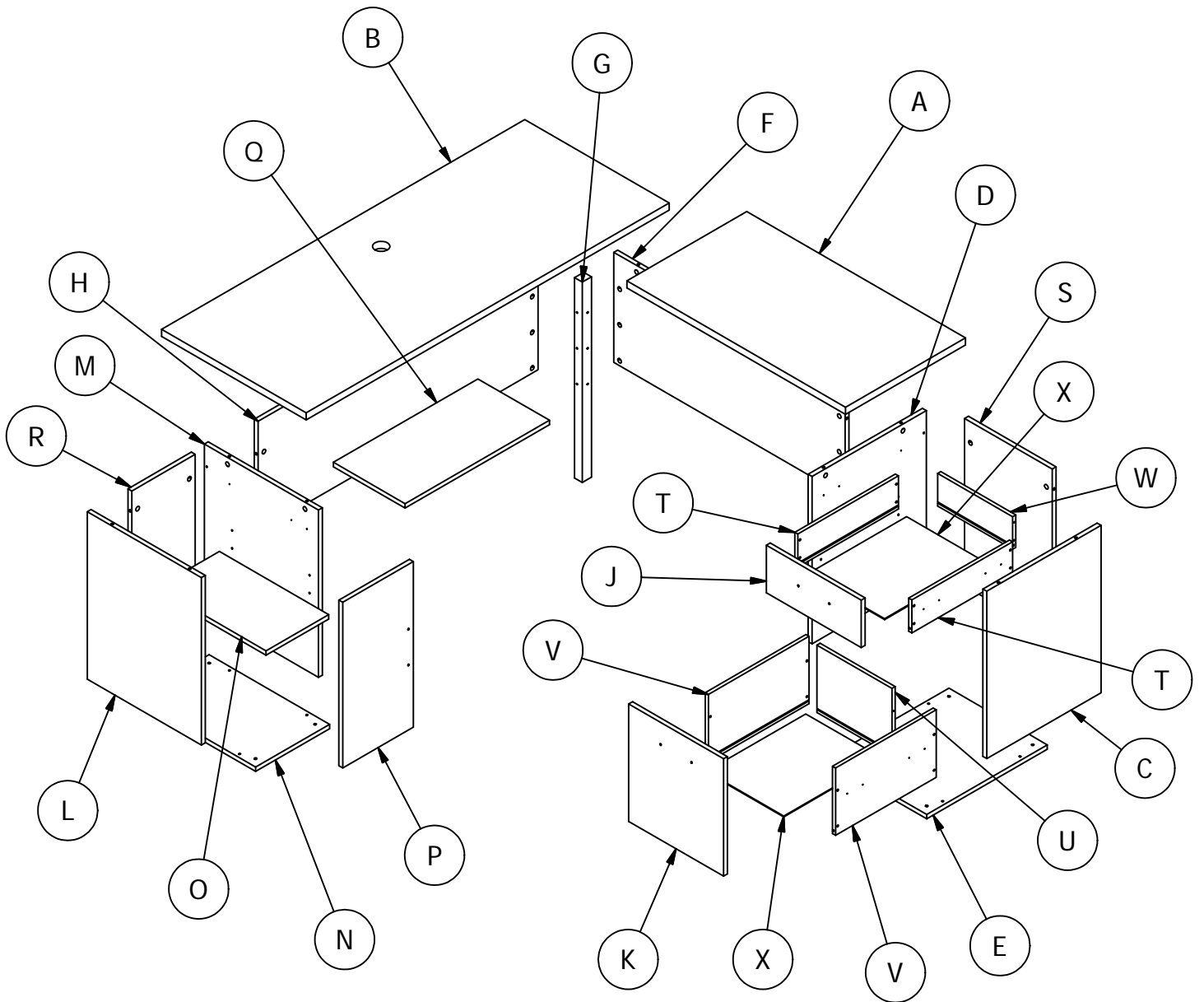
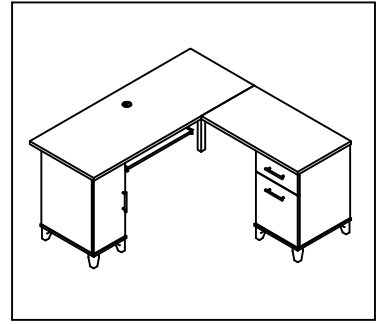

# PARTS LIST

---

A	[1]	N	[1]
B	[1]	O	[1]
C	[1]	P	[1]
D	[1]	Q	[1]
E	[1]	R	[1]
F	[1]	S	[1]
G	[1]	T	[2]
H	[1]	U	[1]
J	[1]	V	[2]
K	[1]	W	[1]
L	[1]	X	[2]
M	[1]		

# FASTENERS

Fasteners are shown in actual size.  
los fijadores son demostrados en su tamaño actual.  
les attaches sont montrées dans l'échelle grandeur.

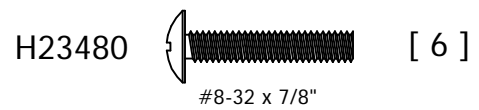
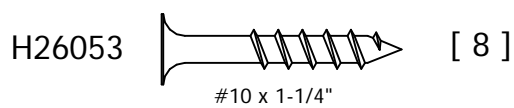
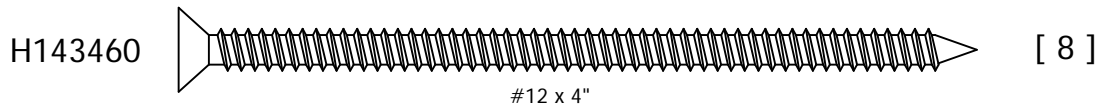
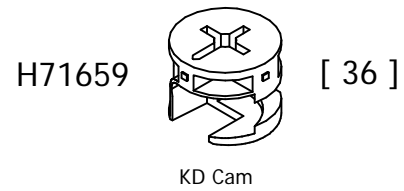
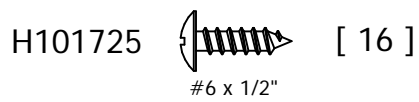
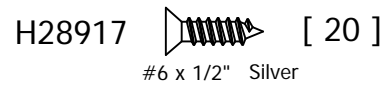
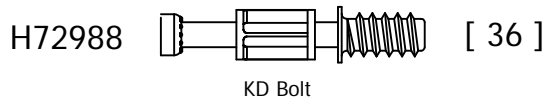
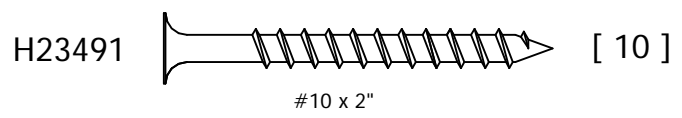
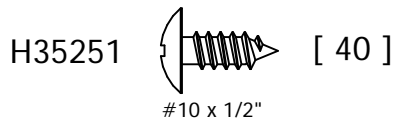

# HARDWARE

H89898

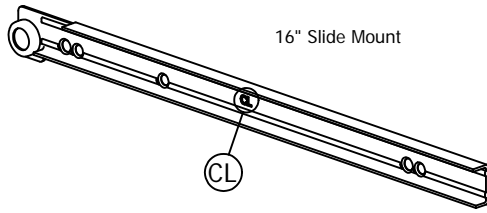

16" Slide Mount

[ 1 ]

H100445

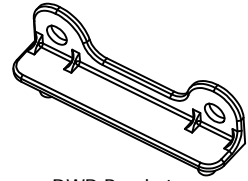

DWR Bracket

[ 2 ]

H89899

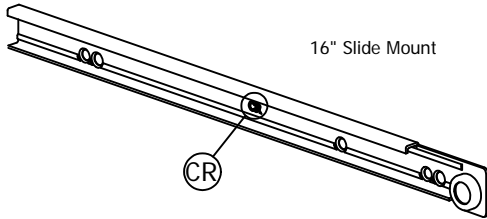

16" Slide Mount

[ 1 ]

H100446

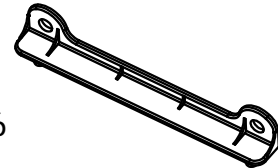

Drawer Bracket

[ 2 ]

H89900

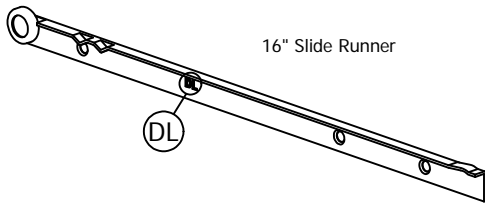

16" Slide Runner

[ 1 ]

H162488

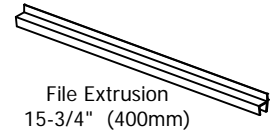

File Extrusion  
15-3/4" (400mm)

[ 2 ]

H89901

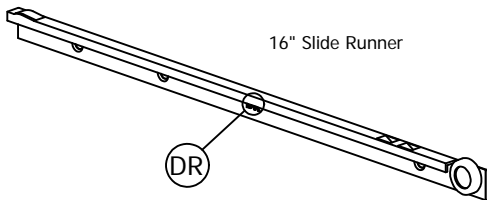

16" Slide Runner

[ 1 ]

H39922

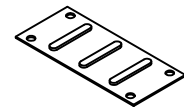

Strap

[ 2 ]

H162814

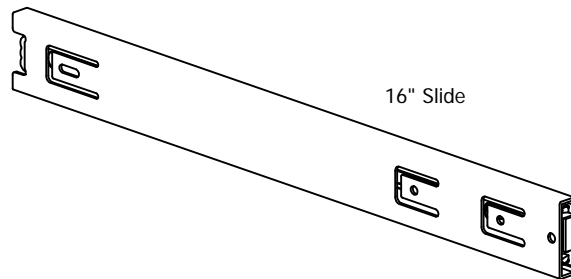

16" Slide

[ 2 ]

# HARDWARE

H126364

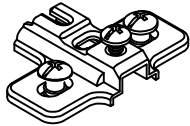

Mounting Plate

[ 2 ]

H126359

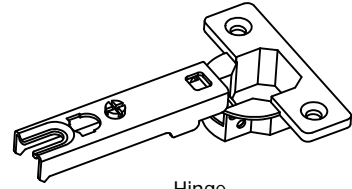

Hinge

[ 2 ]

H23604



Shelf Pin

[ 4 ]

H150001

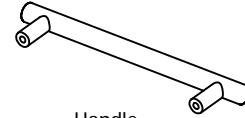

Handle

[ 3 ]

H126396

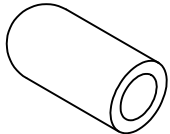

Shelf Pin Sleeve

[ 4 ]

H77351

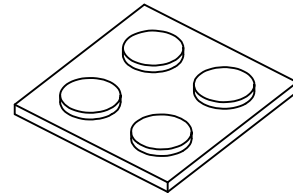

Bumper (4) per pack

[ 2 ]

Z92806

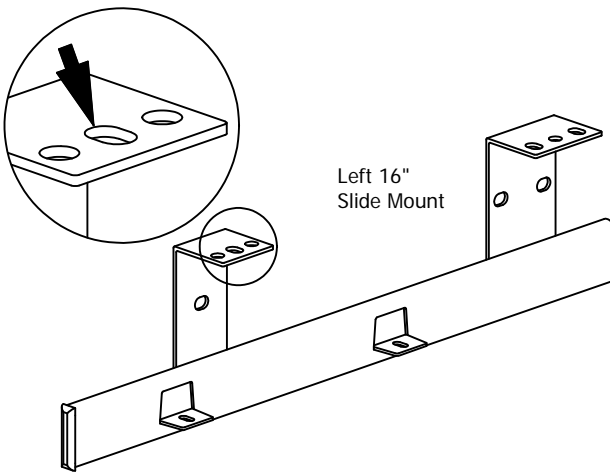

Left 16"  
Slide Mount

[ 1 ]

Z92807

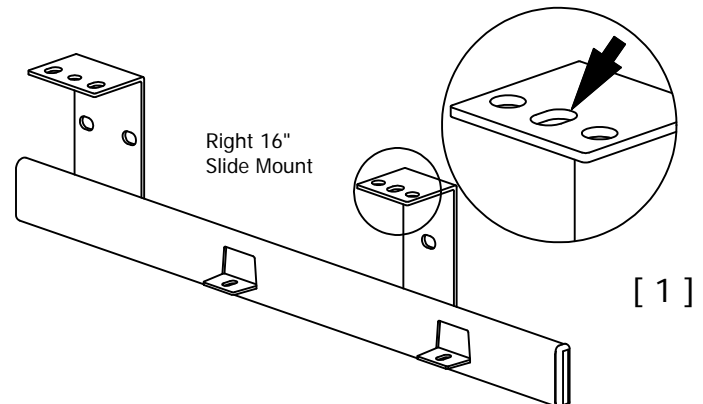

Right 16"  
Slide Mount

[ 1 ]

# MODEL SPECIFIC

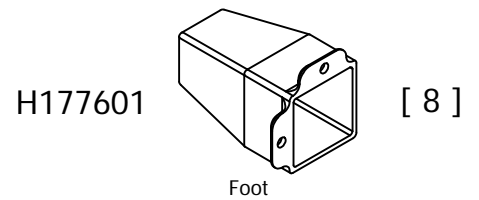
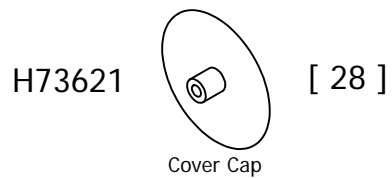
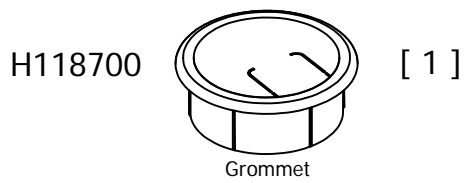
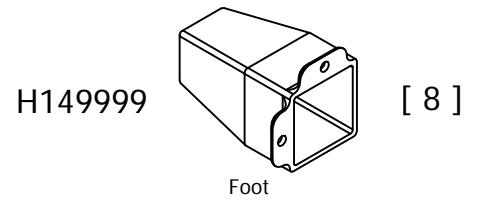
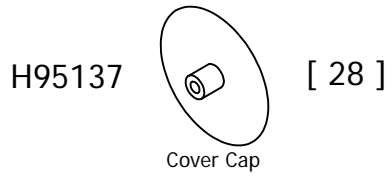
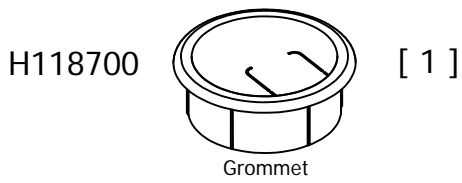
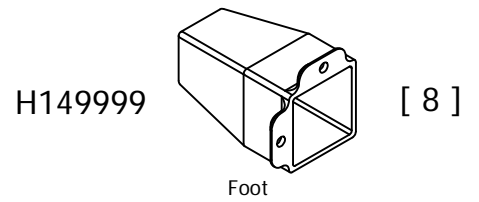
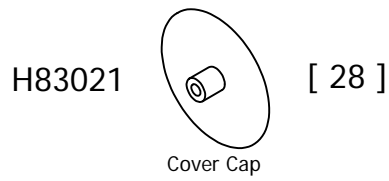
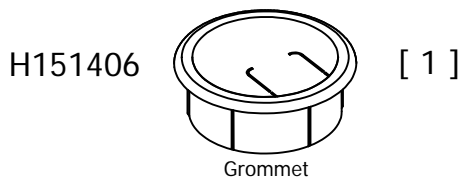
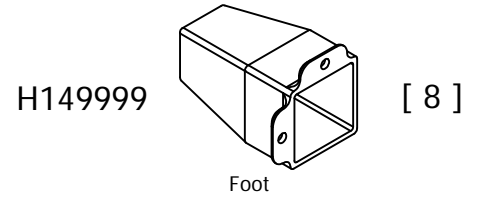
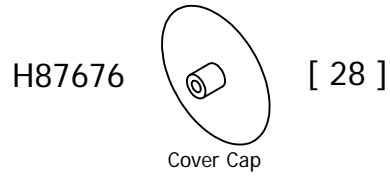
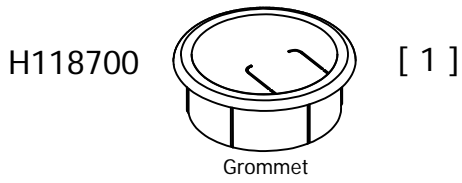

# STEP 1

H162814

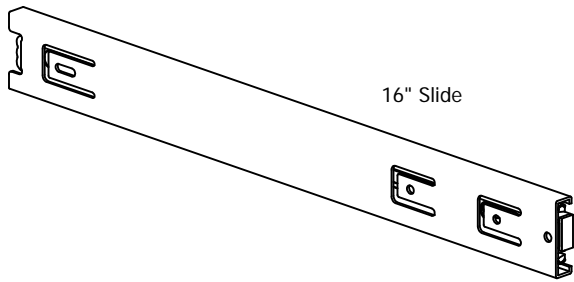

16" Slide

[ 2 ]

WATCH VIDEO

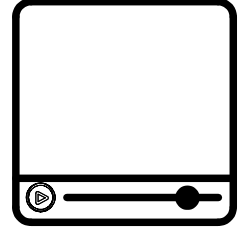

Separate and Install  
Drawer Slides

Move lock lever on the runner as shown to separate runner from mount and cage.

Mueva la palanca de seguro en el corredor del montaje y el casillero como se muestra.

Déplacez le levier de verrouillage sur le coulisseau comme illustré pour séparer le coulisseau de la monture et la cage.

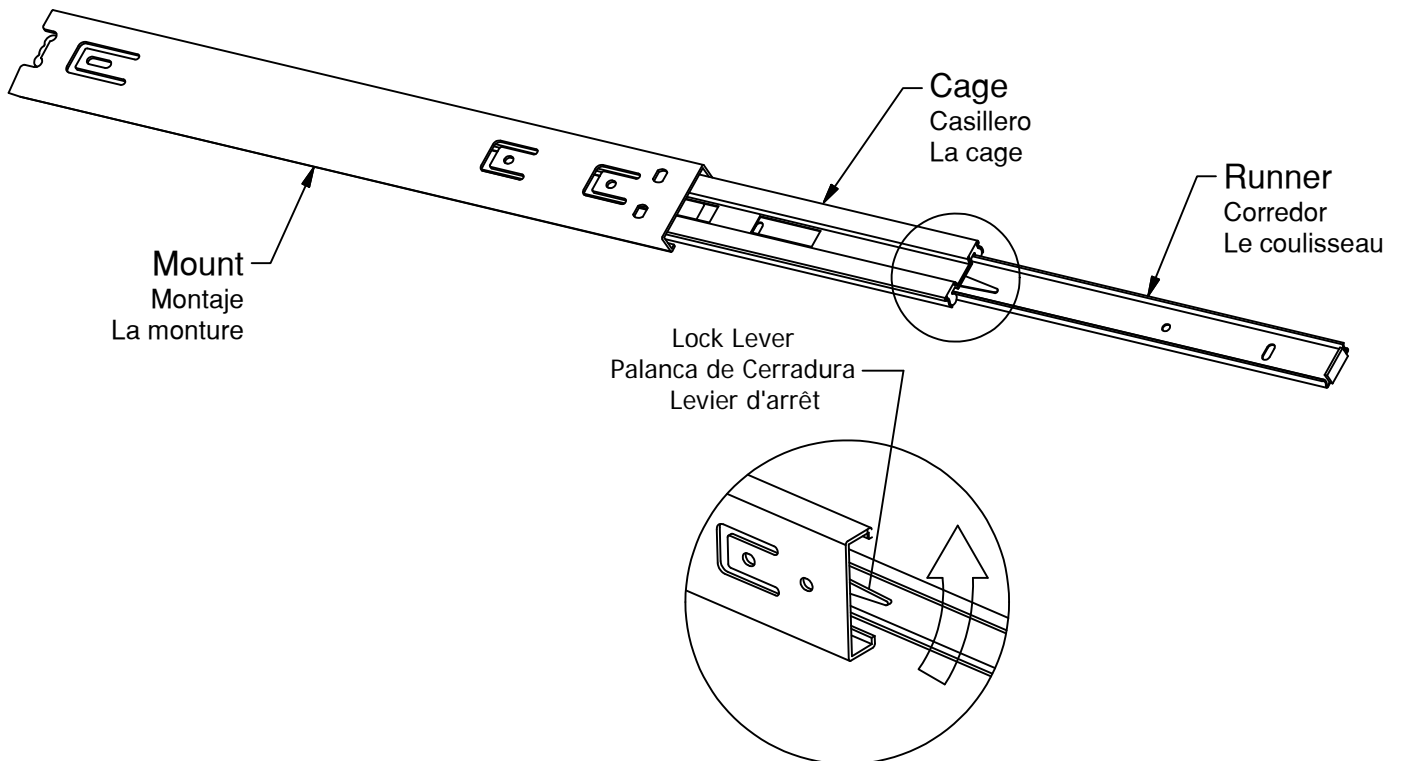

Set runner aside to be used later in the Assembly Instructions.

Haga el corredor hacia un lado porque sera utilizado mas adelante.

Mettez le coulisseau de côté pour être utilisé plus tard dans les instructions d'assemblage.

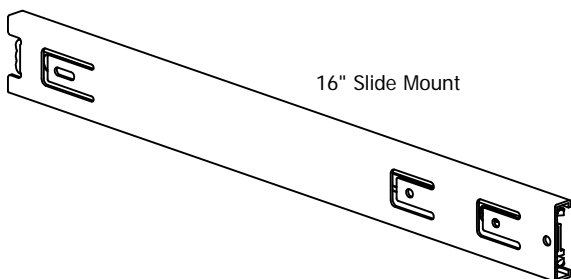

16" Slide Mount

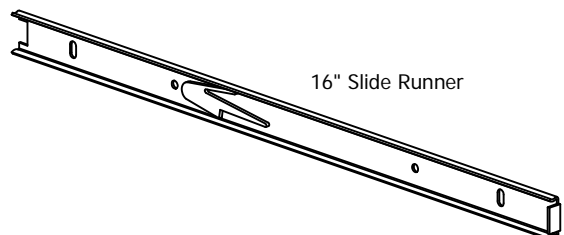

16" Slide Runner

**STEP 2**

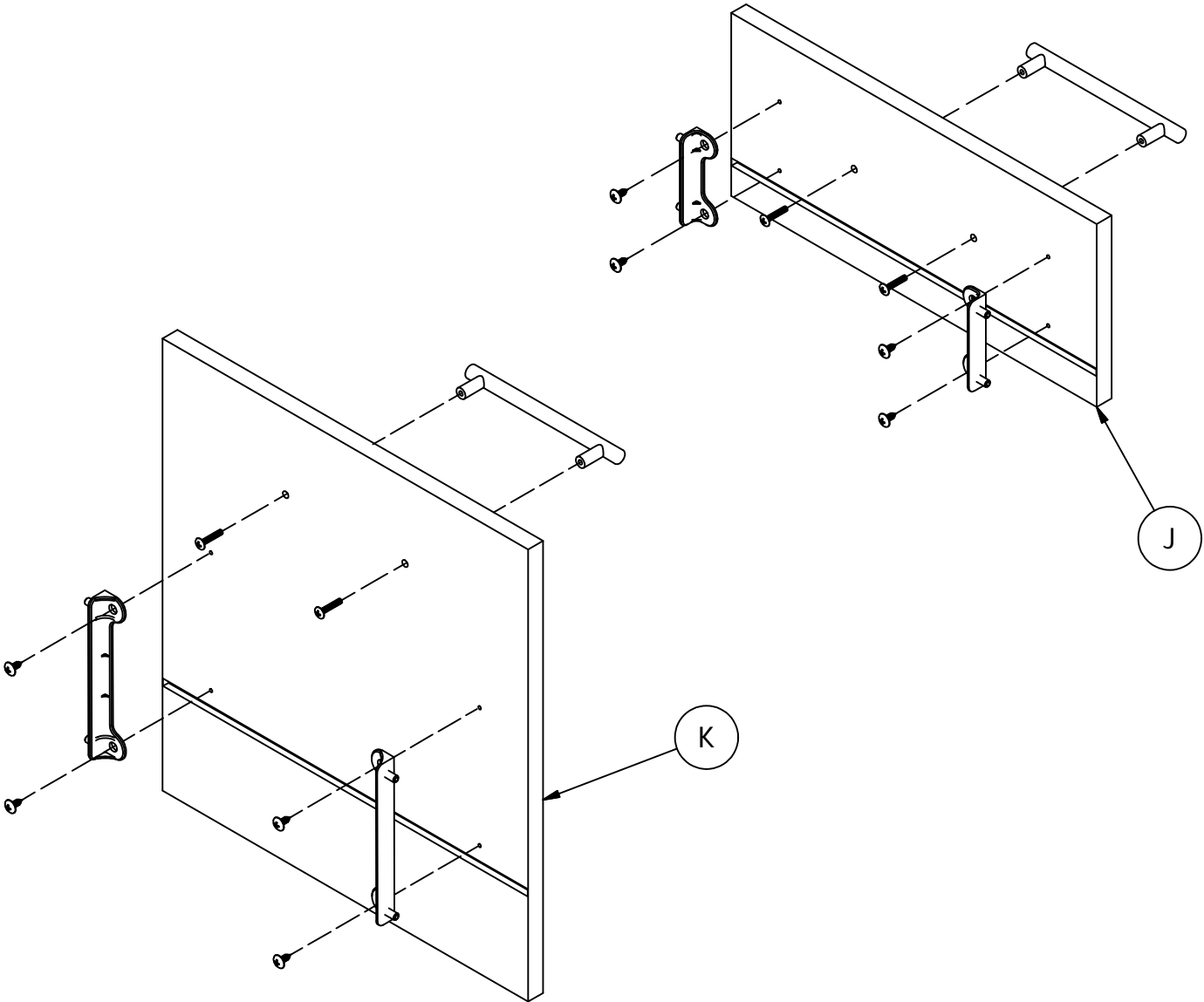
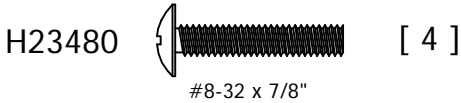
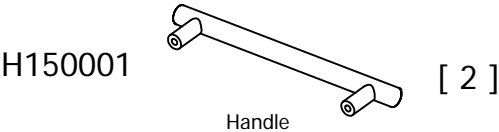
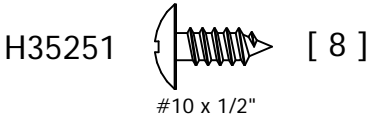
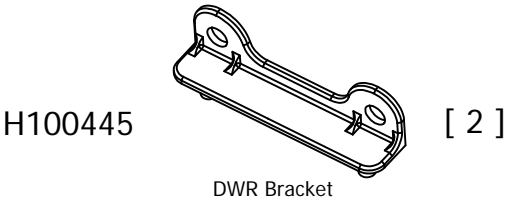
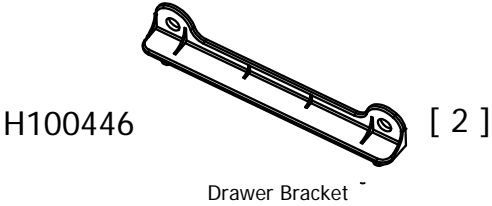

# STEP 3

H28917  [ 10 ]  
#6 x 1/2" Silver

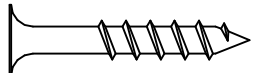
H26053  [ 4 ]  
#10 x 1-1/4"

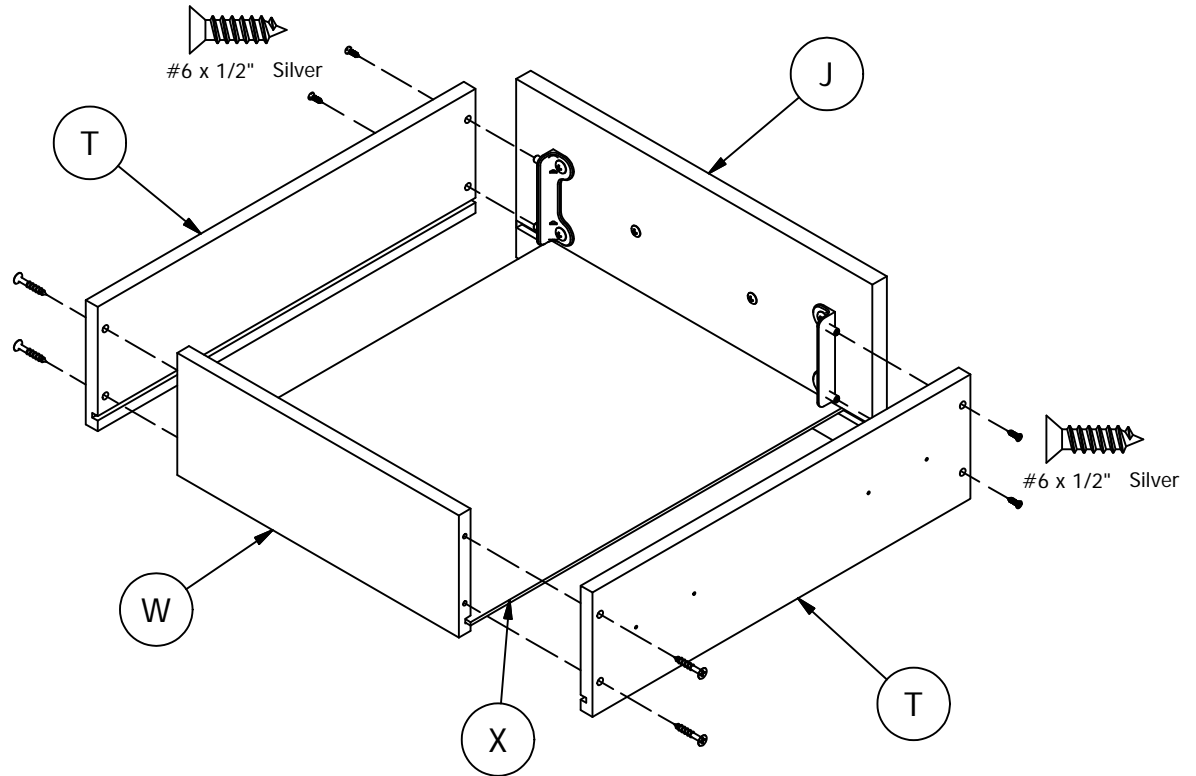

H89900

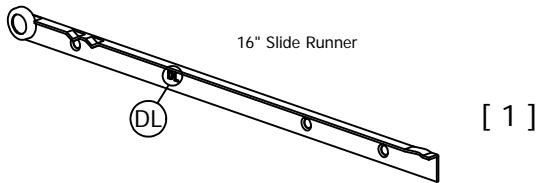

H89901

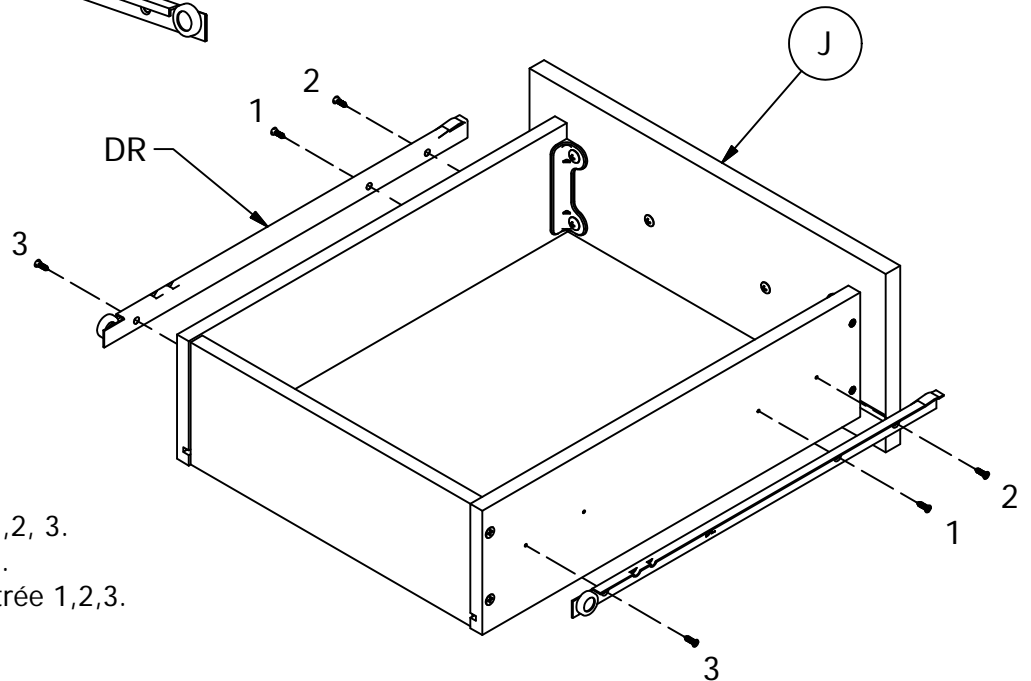
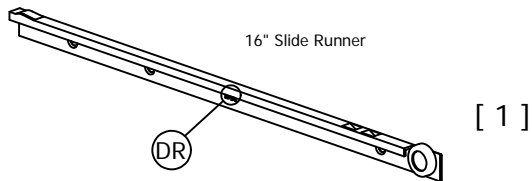

Tighten screws in order shown 1,2,3.  
Atornille en orden indicado 1,2,3.  
Serrer les vis dans la façon montrée 1,2,3.

# STEP 4

H101725 [ 10 ]  
#6 x 1/2"

H26053 [ 4 ]  
#10 x 1-1/4"

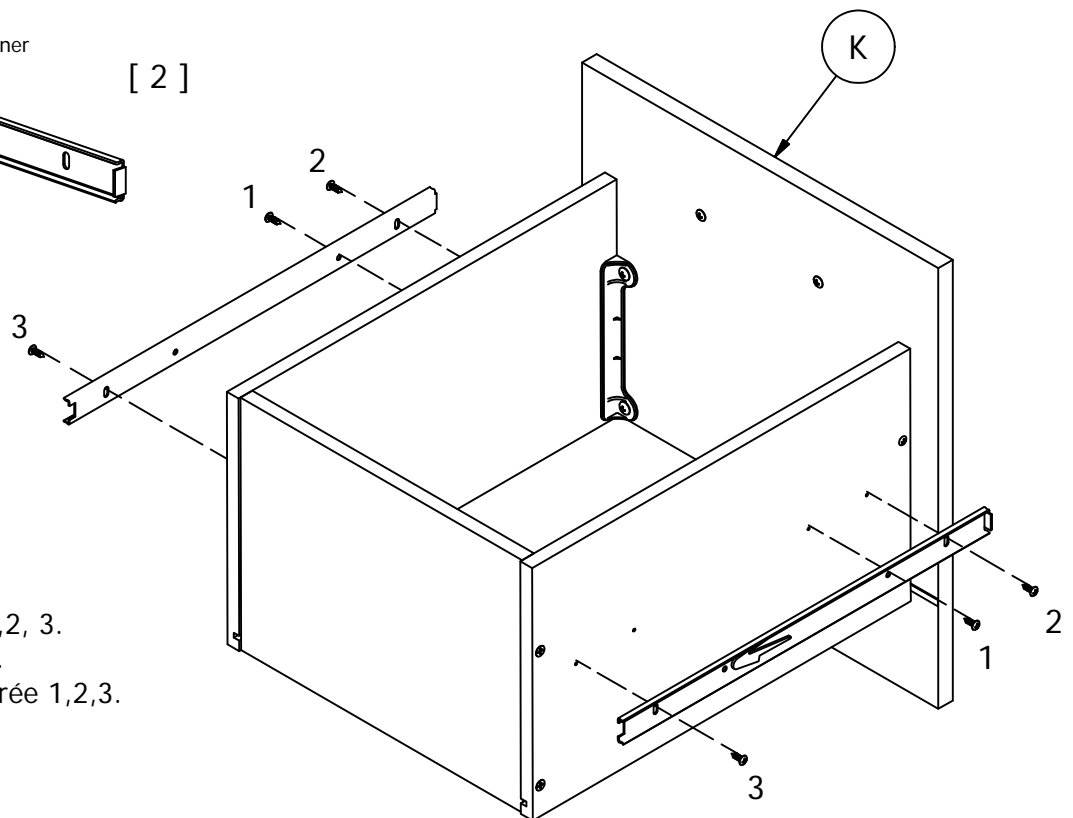
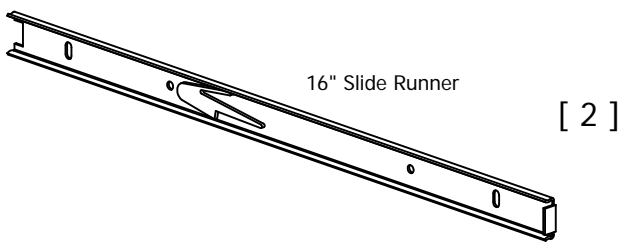
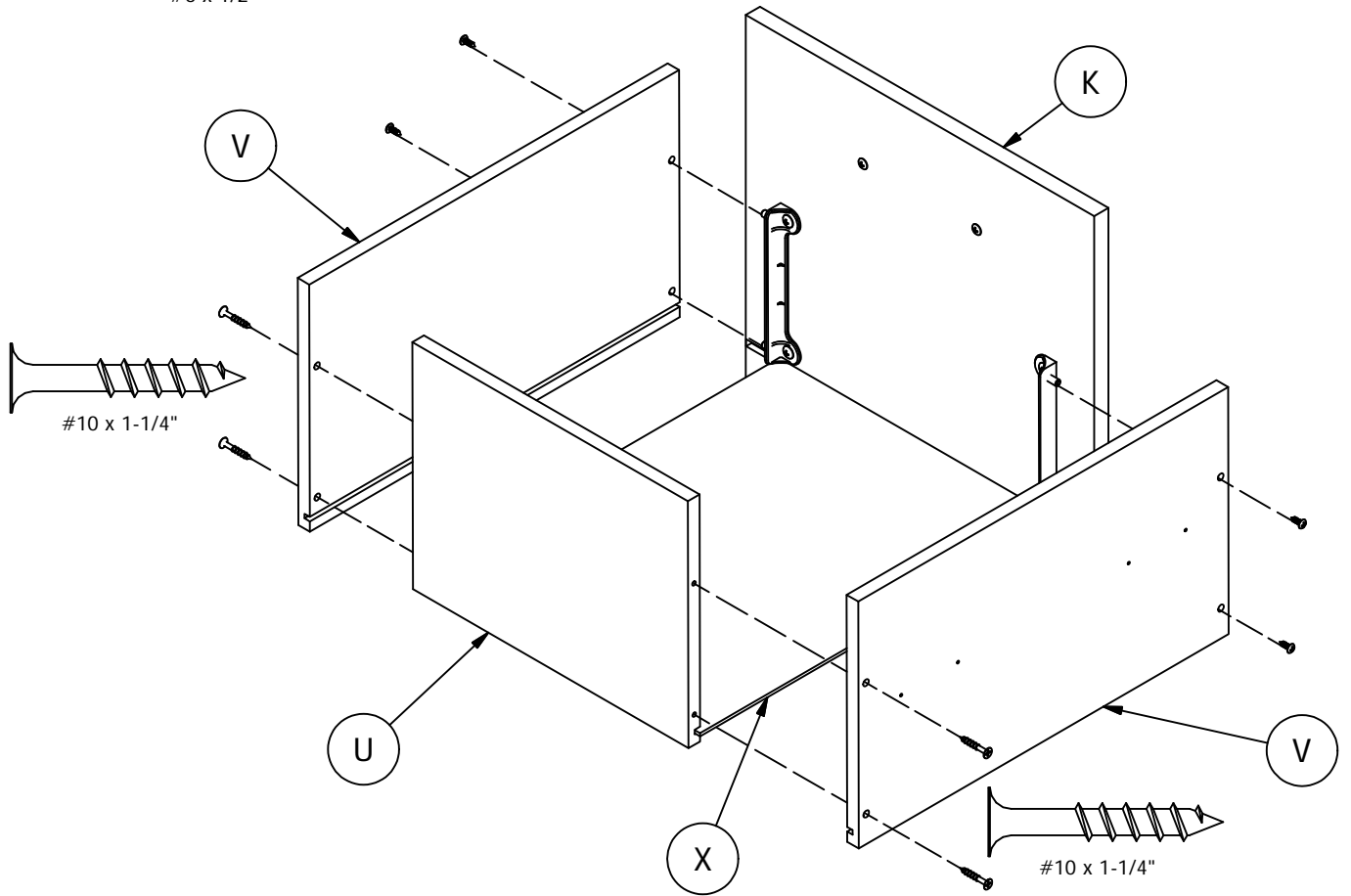

Tighten screws in order shown 1,2, 3.  
Atornille en orden indicado 1,2,3.  
Serrer les vis dans la facon montrée 1,2,3.

**STEP 5**

H162488

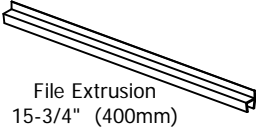

[ 2 ]

H77351



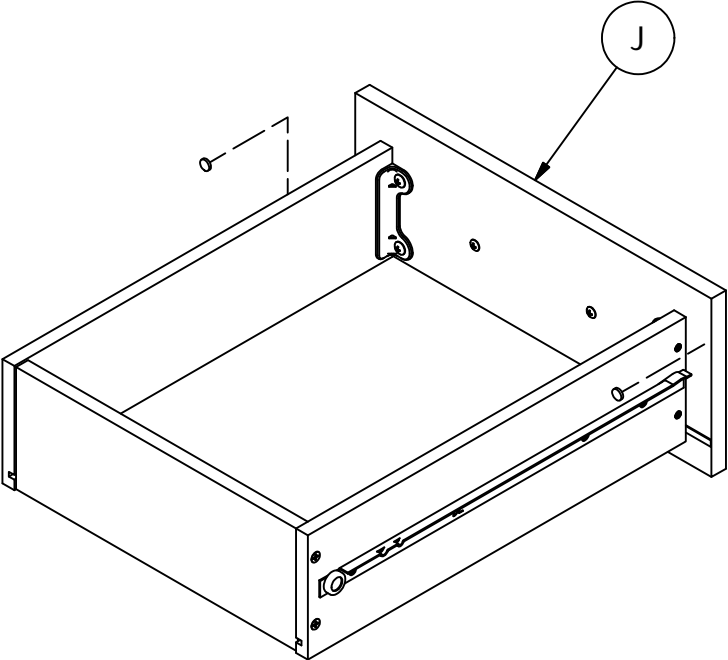
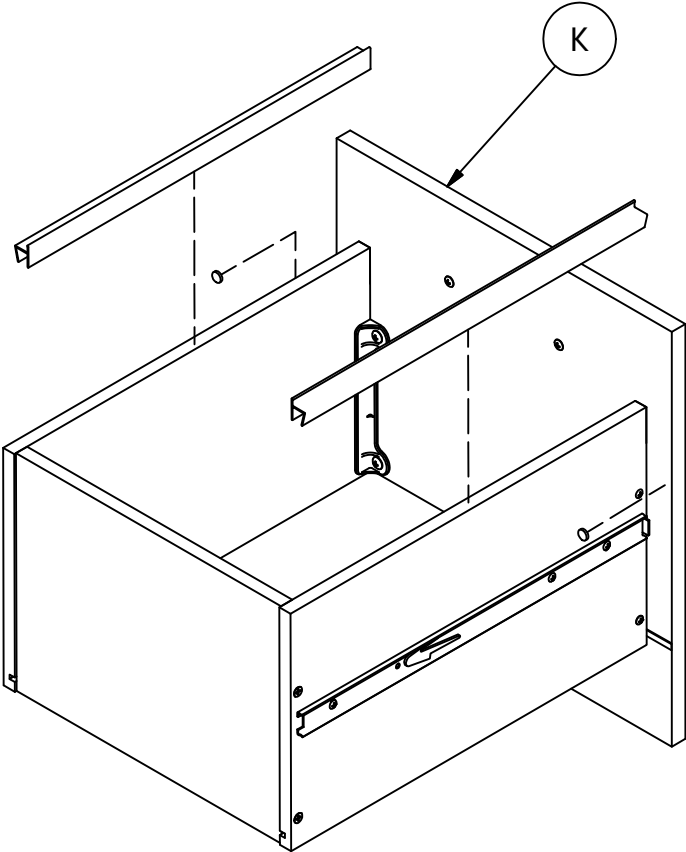

[ 4 ]



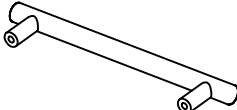

**STEP 6**

H150001  [ 1 ]  
Handle

H23480  [ 2 ]  
#8-32 x 7/8"

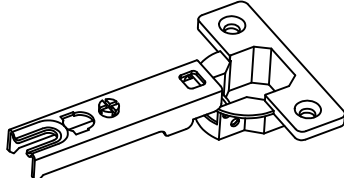
H28917  [ 4 ]  
#6 x 1/2" Silver

H126359  [ 2 ]  
Hinge

H77351  [ 2 ]  
Bumper

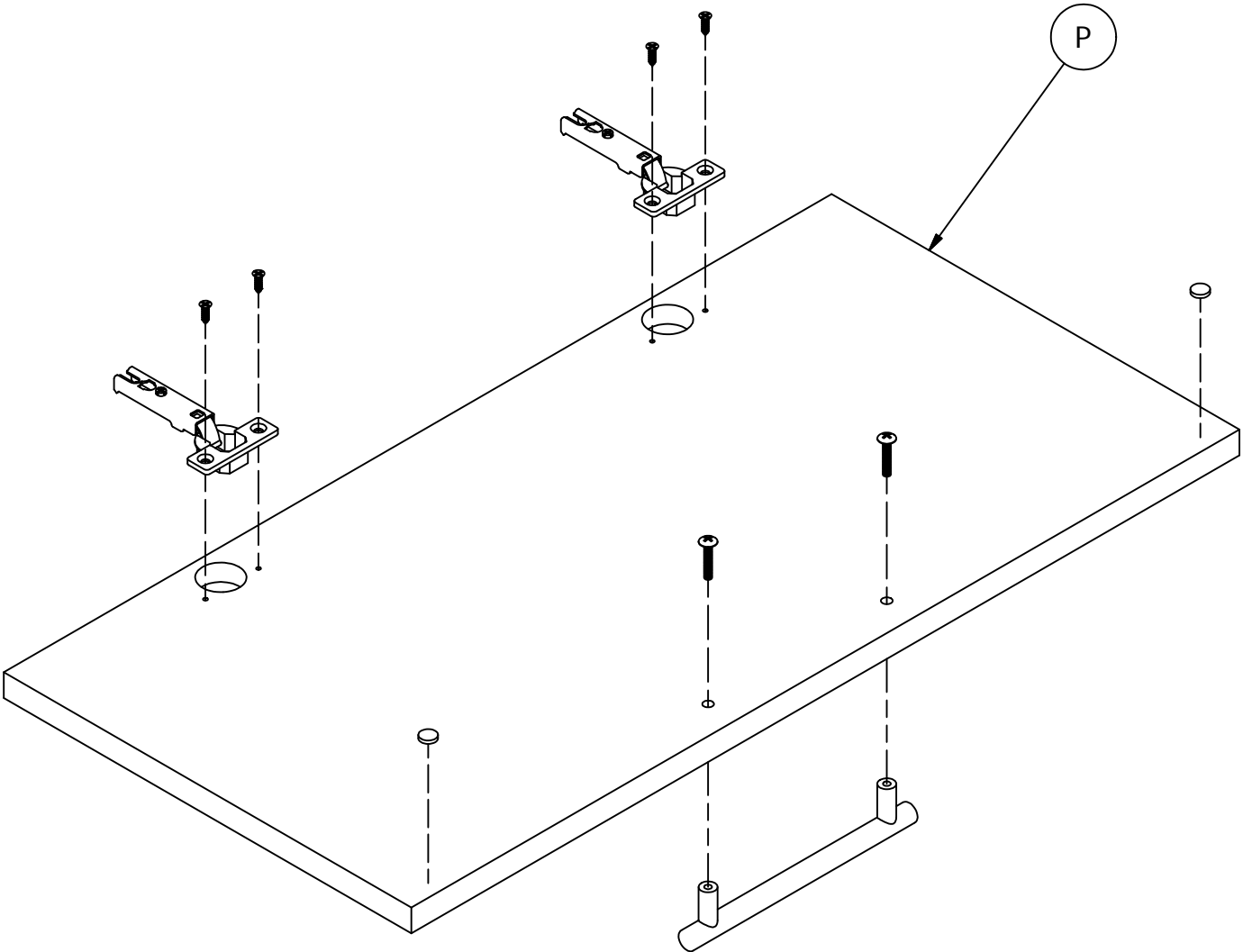

# STEP 7

H72988 [ 6 ]  
KD Bolt

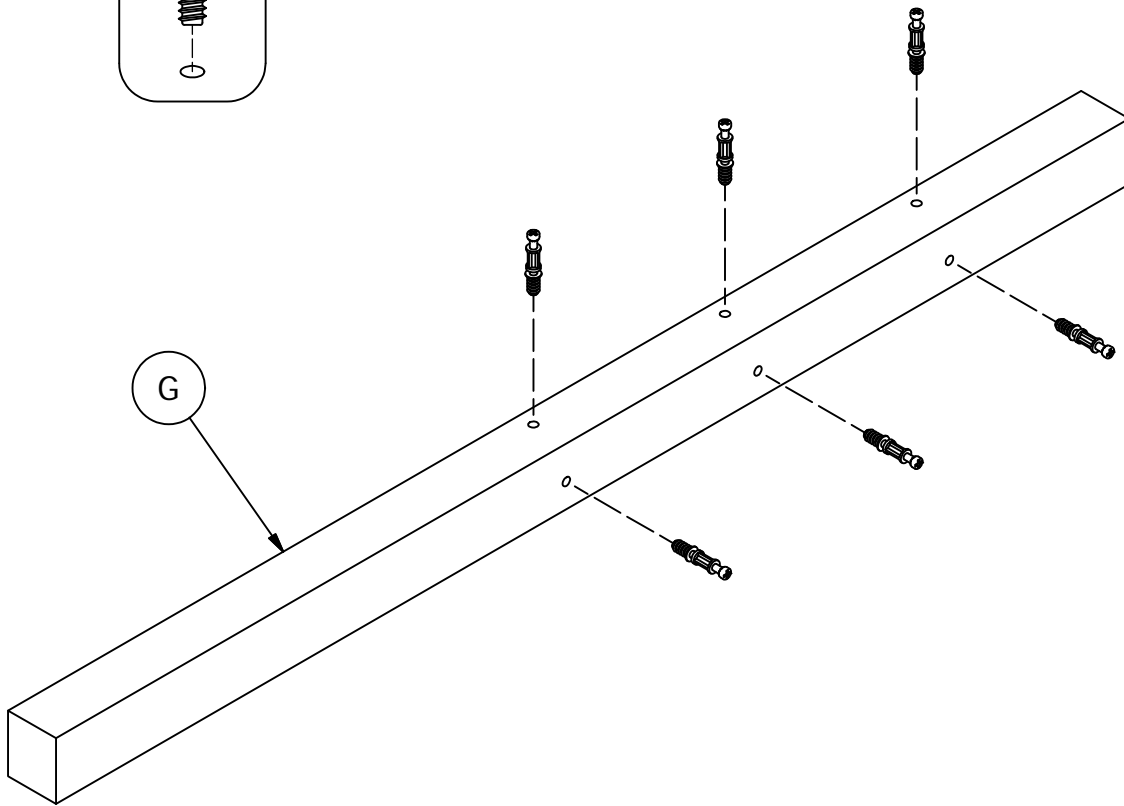
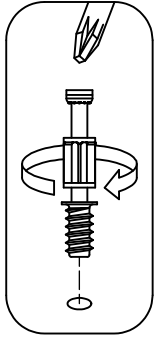

**STEP 8**

---

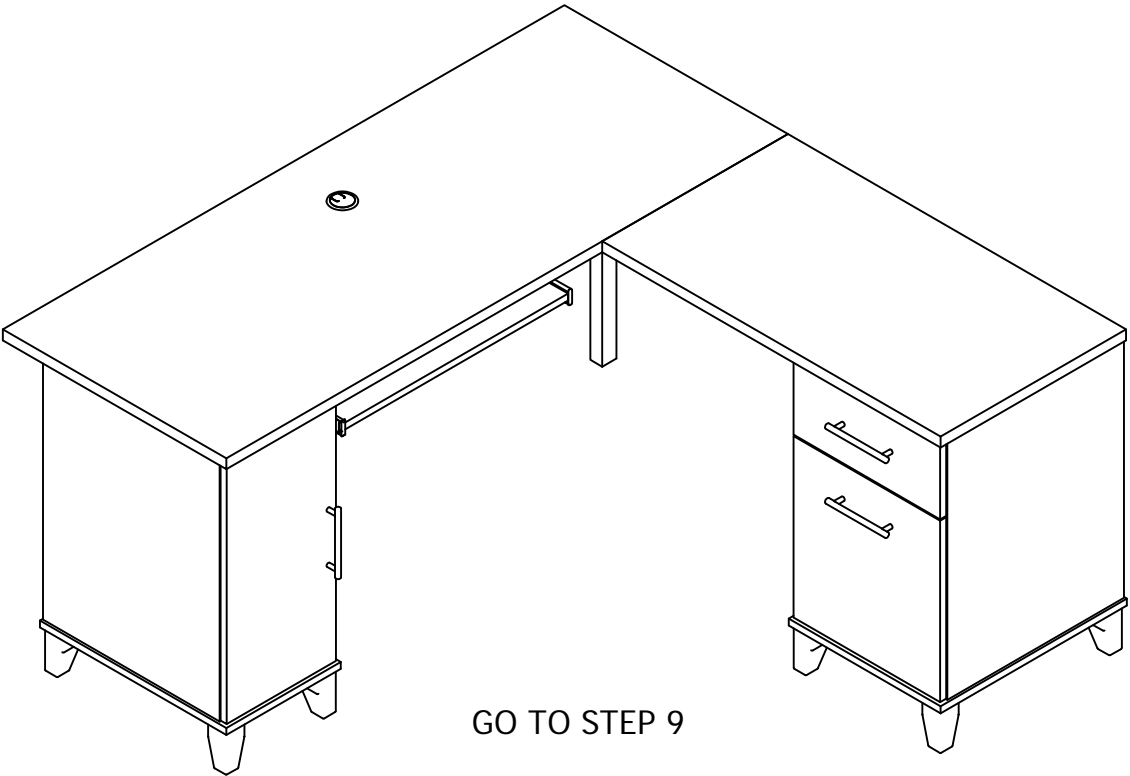

GO TO STEP 9

---

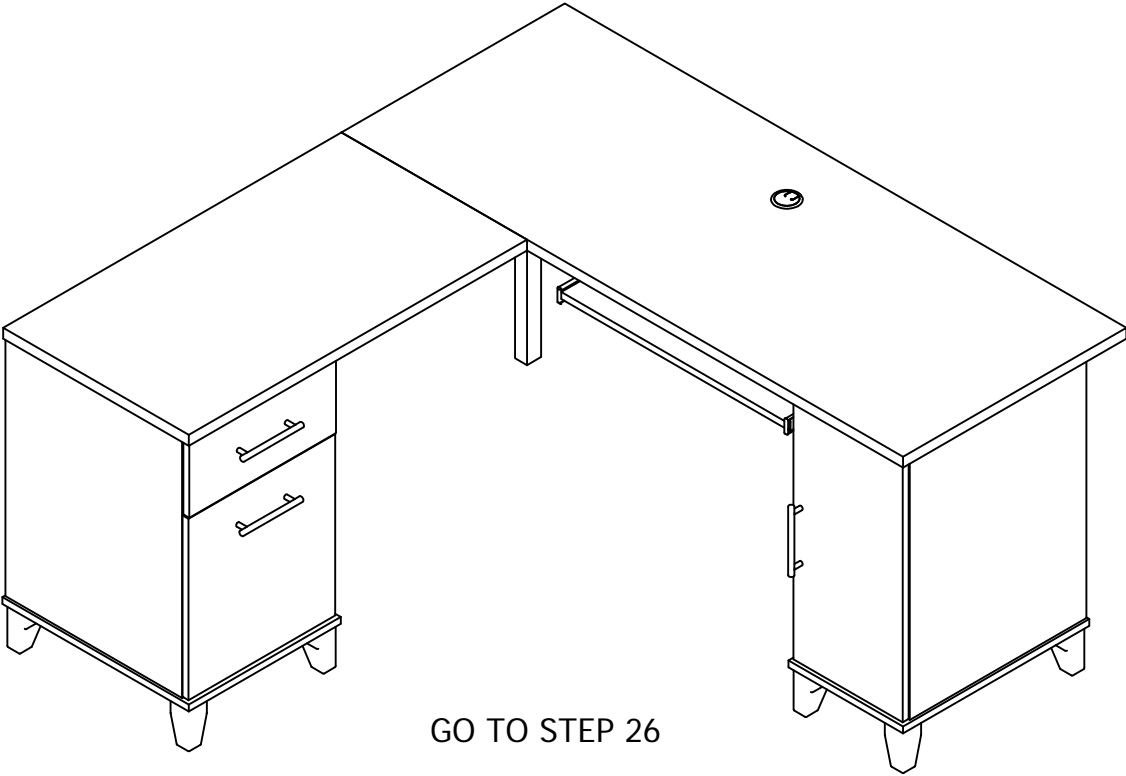

GO TO STEP 26

# STEP 9

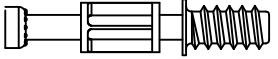
H72988  [ 7 ]  
KD Bolt

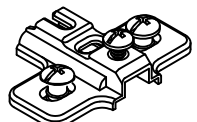
H126364  [ 2 ]  
Mounting Plate

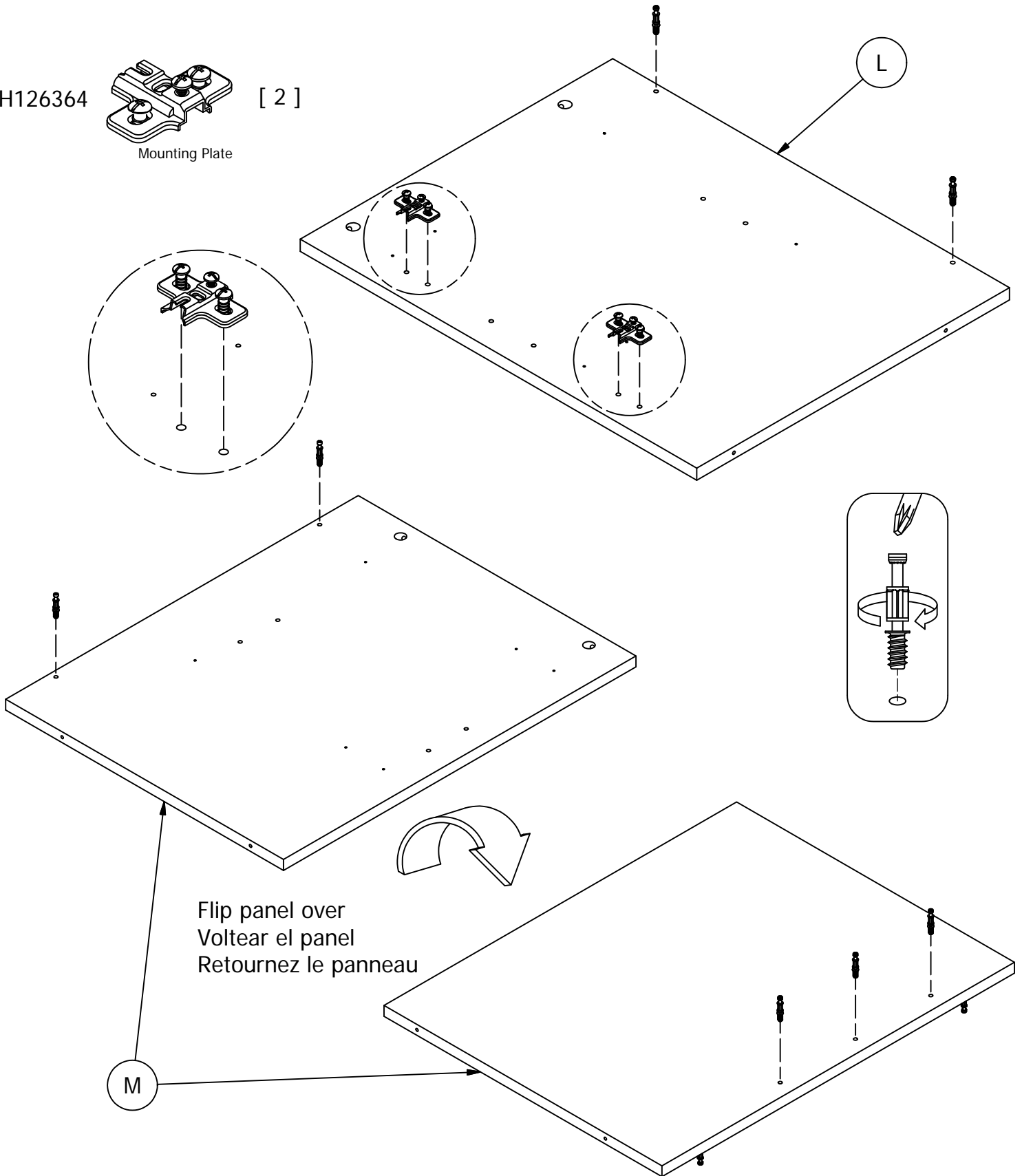

**STEP 10**

H71659

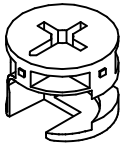

[ 4 ]

KD Cam

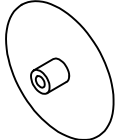
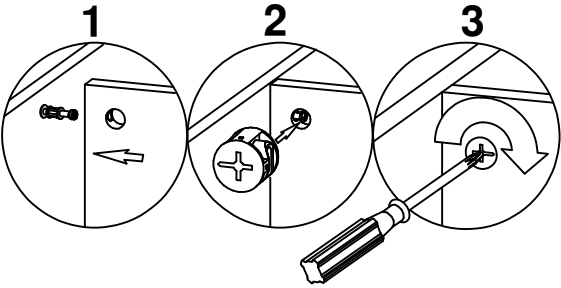

[ 4 ]

Cover Cap

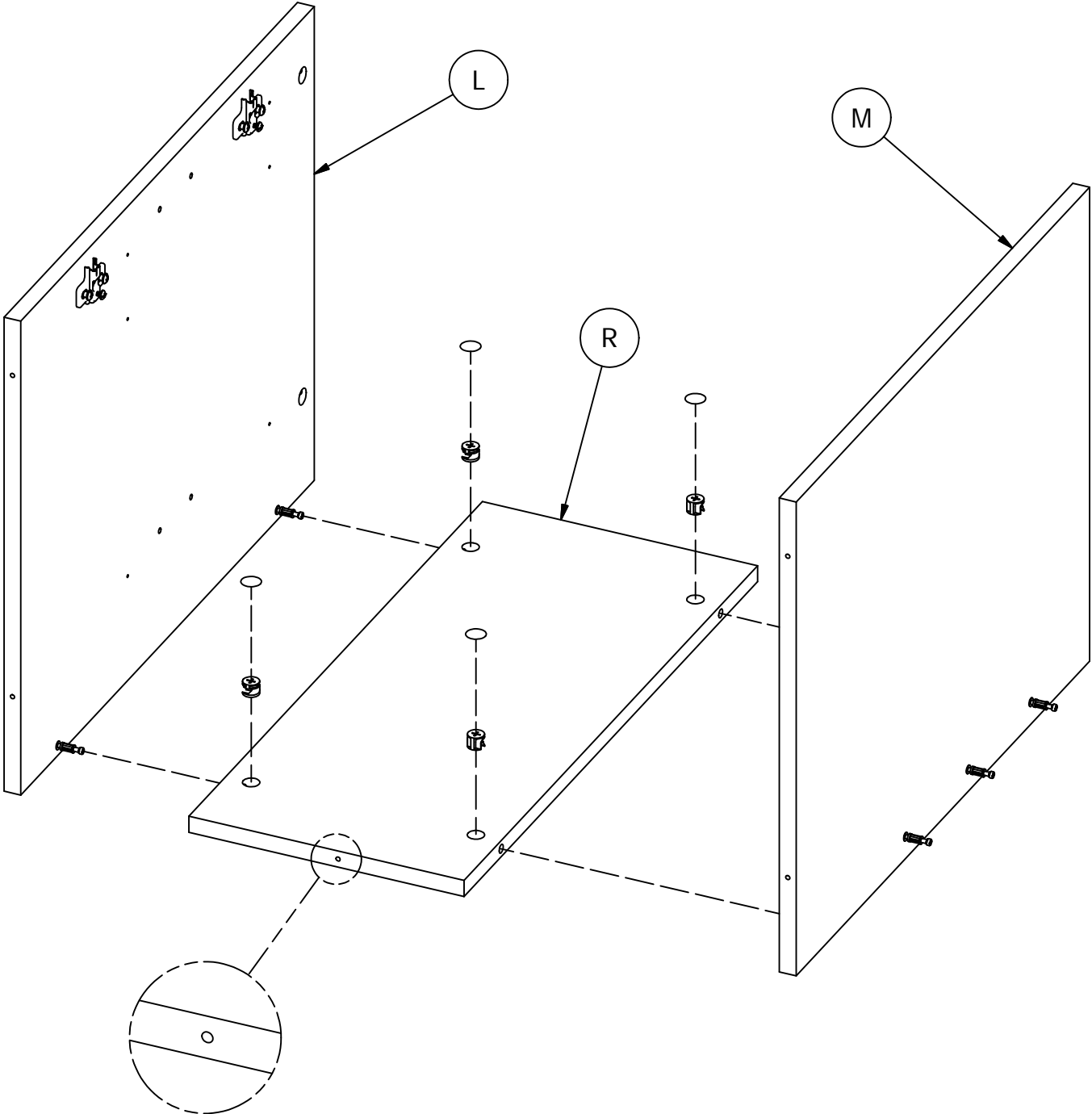

**STEP 11**

H143460

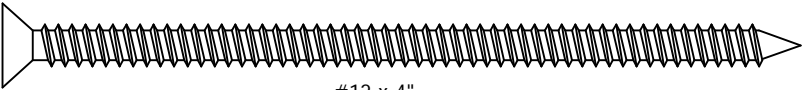

[ 4 ]

#12 x 4"

H35251

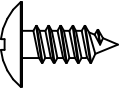

[ 8 ]

#10 x 1/2"

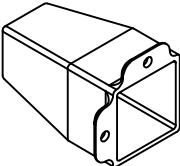

[ 4 ]

Foot

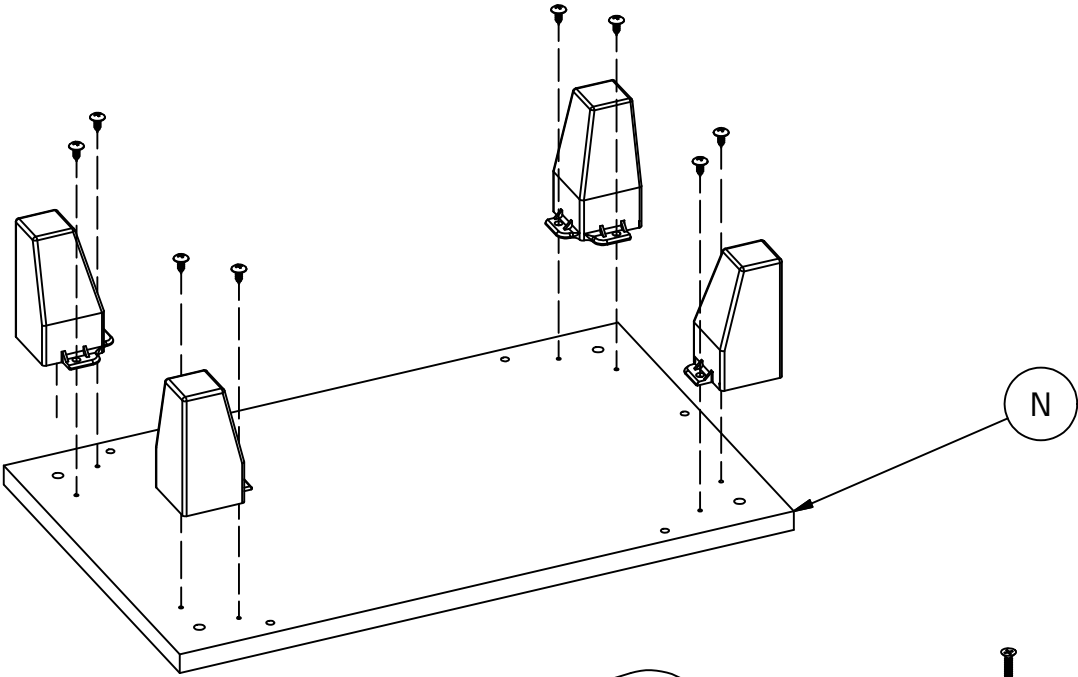

Flip panel over  
Voltear el panel  
Retournez le panneau

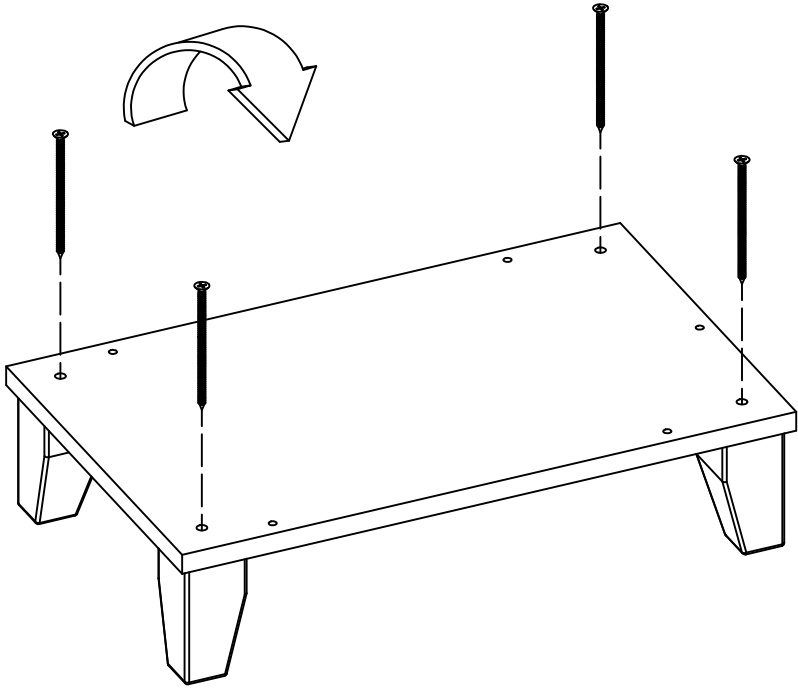

STEP 12

H23491

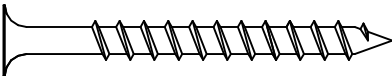

[ 5 ]

#10 x 2"

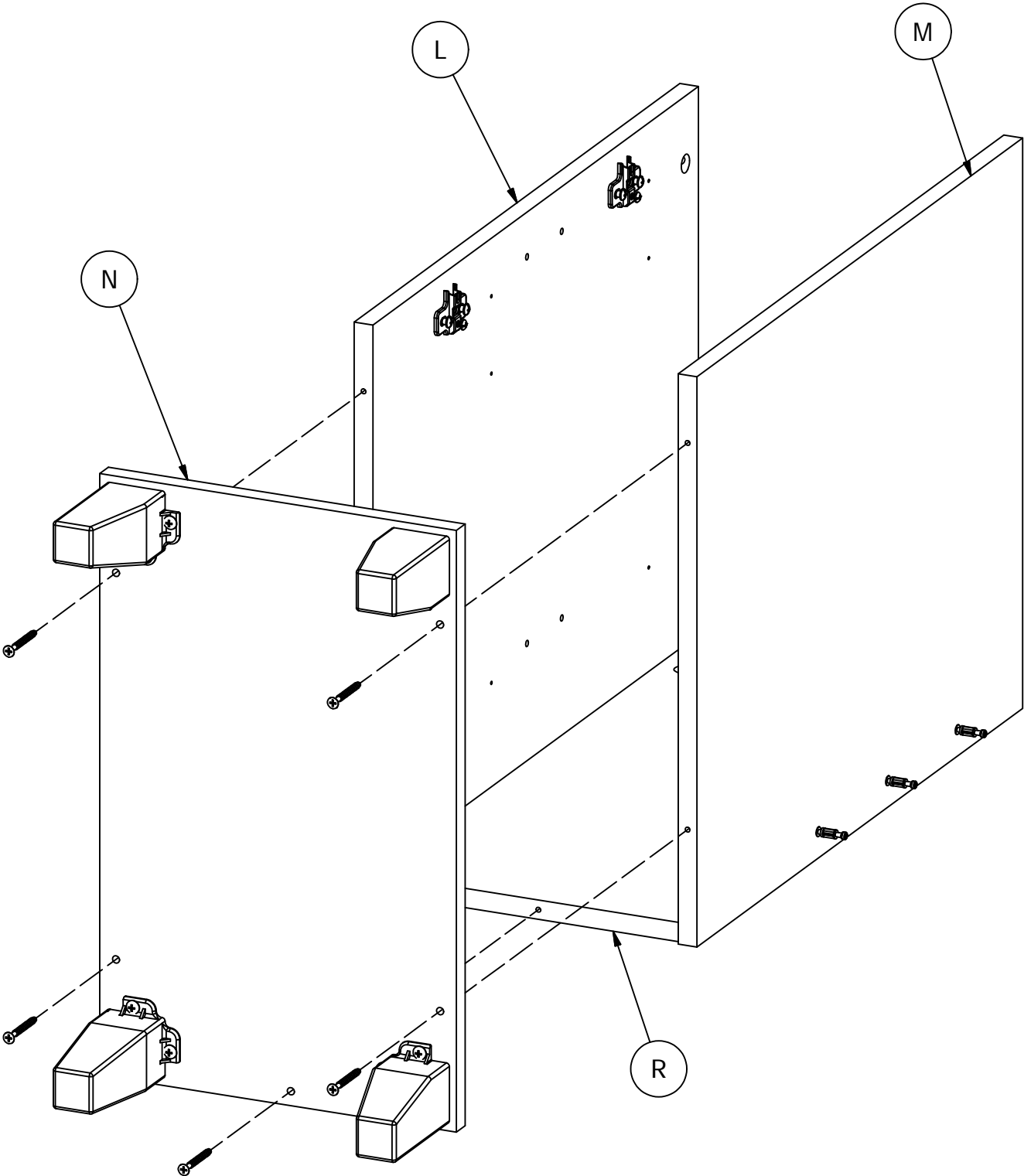

# STEP 13

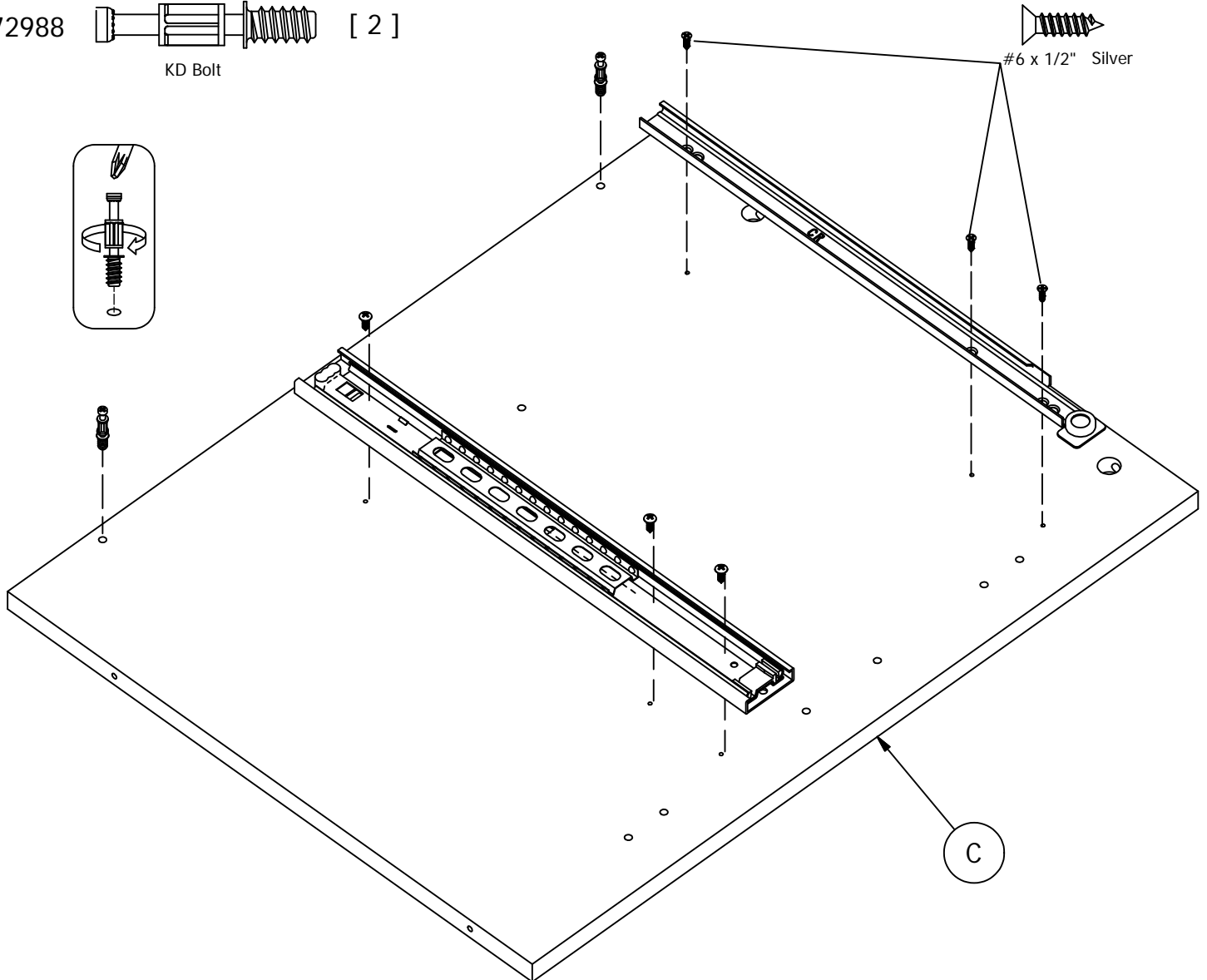
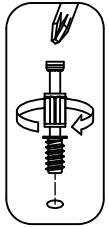
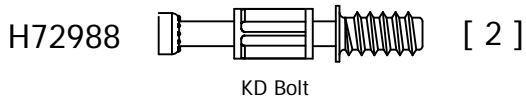
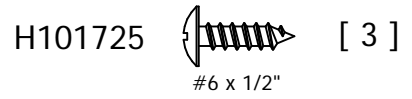
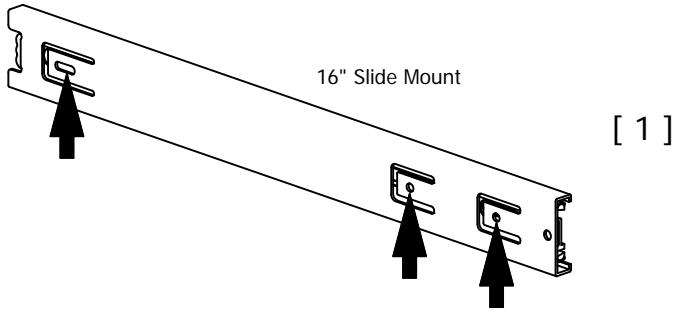
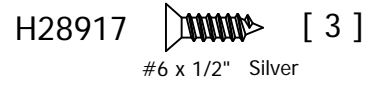
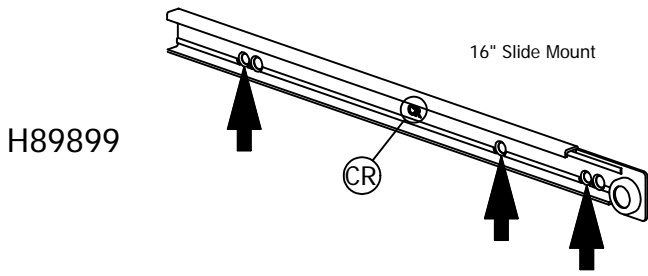

# STEP 14

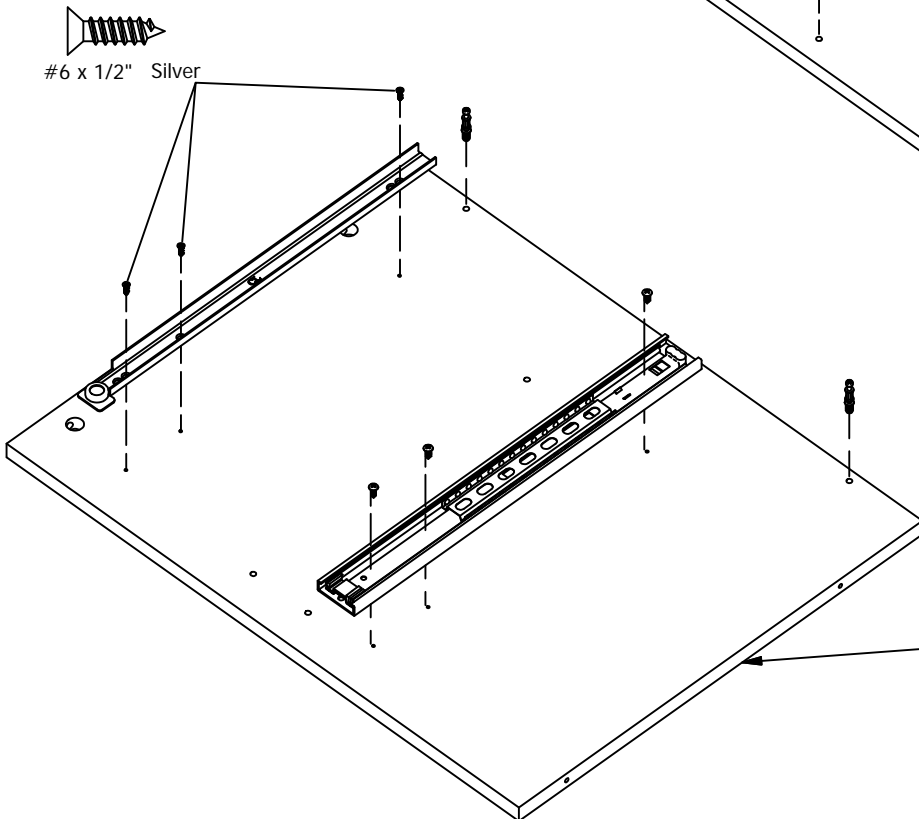
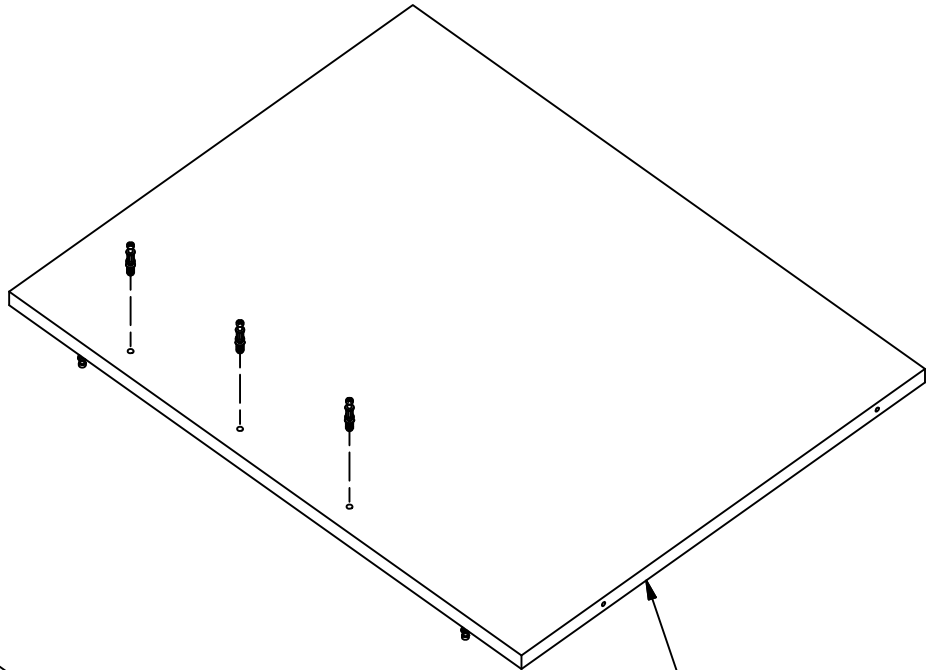
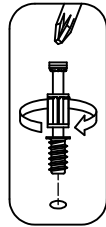
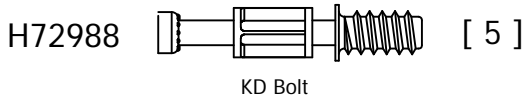
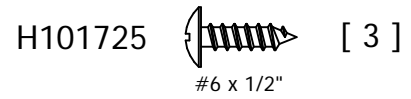
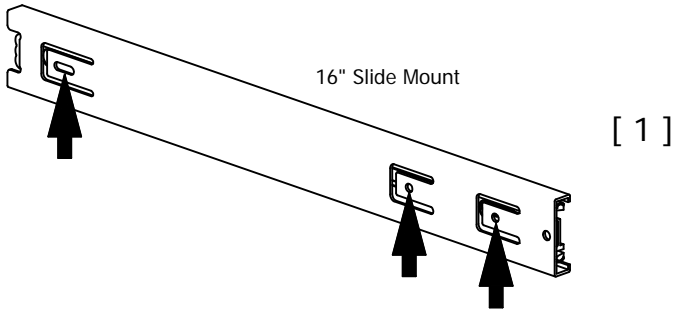
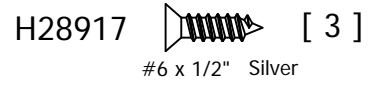
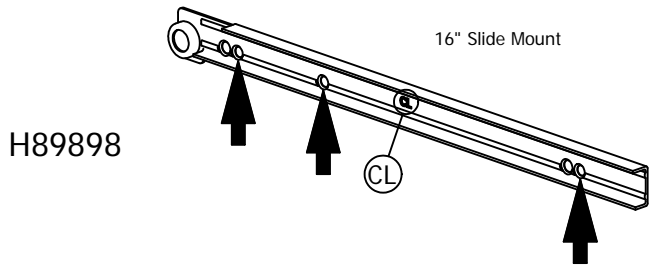

Flip panel over  
Voltear el panel  
Retournez le panneau

D

**STEP 15**

H71659

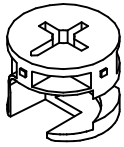

[ 4 ]

KD Cam

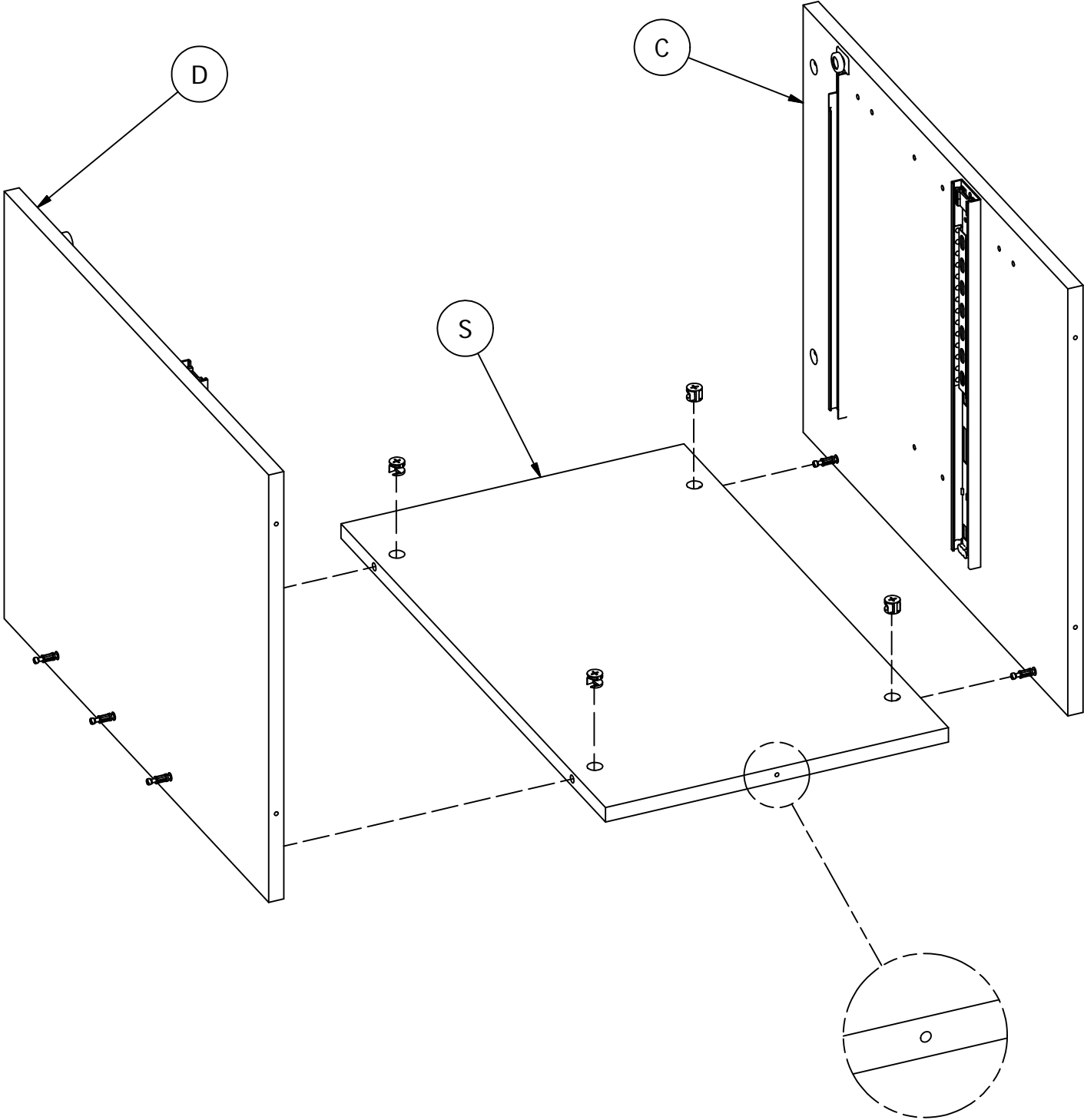
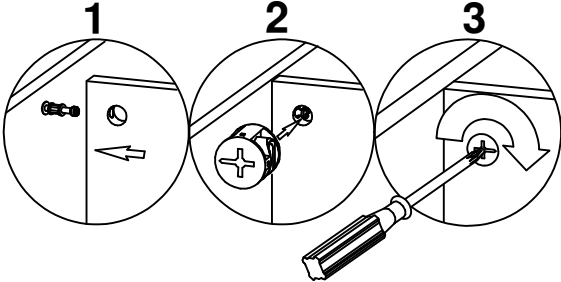

**STEP 16**

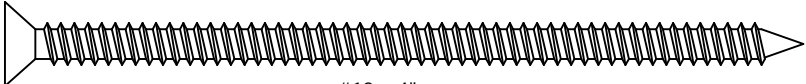
H143460  [ 4 ]  
#12 x 4"

H35251  [ 8 ]  
#10 x 1/2"

 [ 4 ]  
Foot

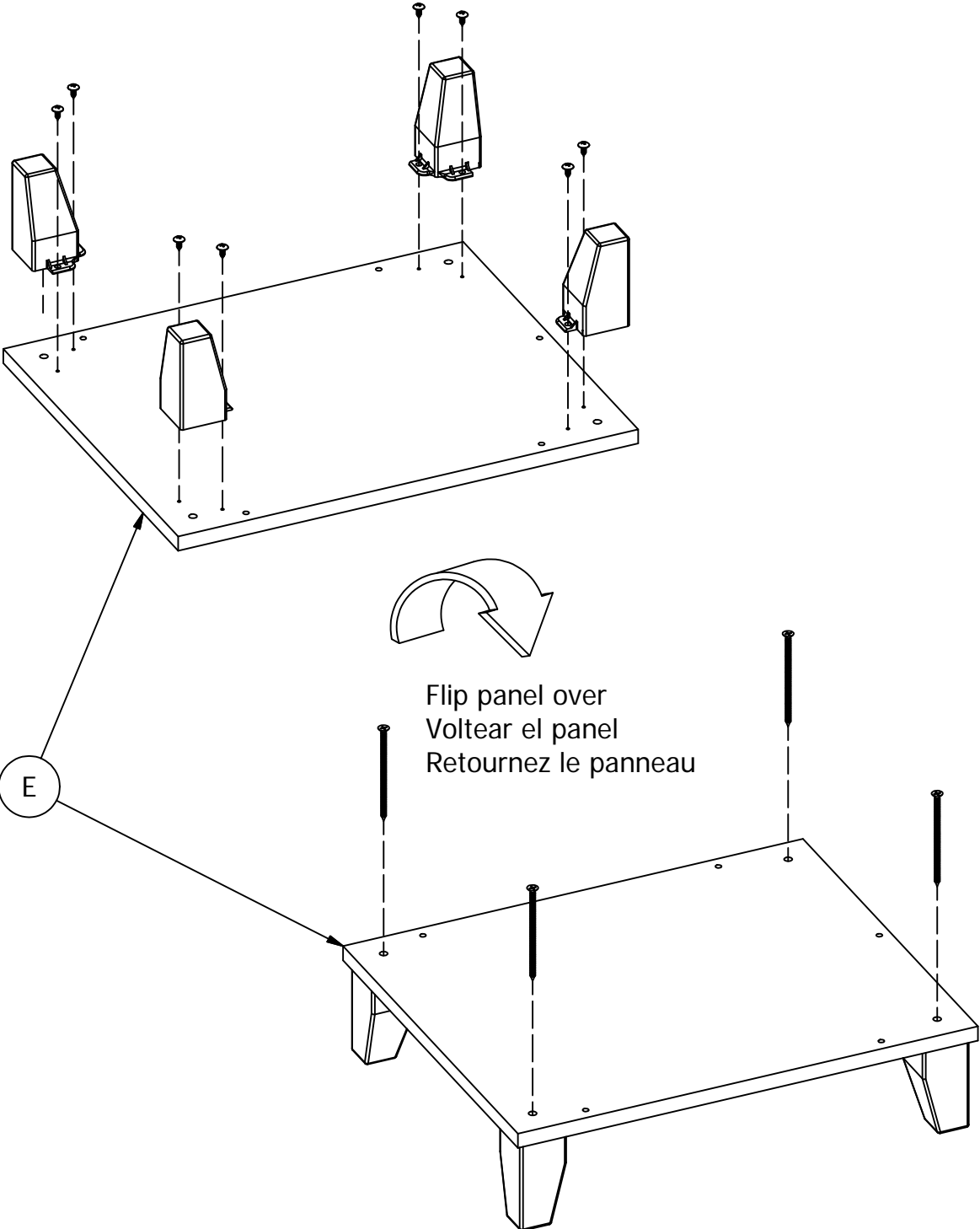

STEP 17

H23491

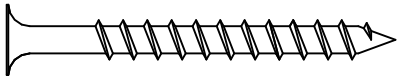

[ 5 ]

#10 x 2"

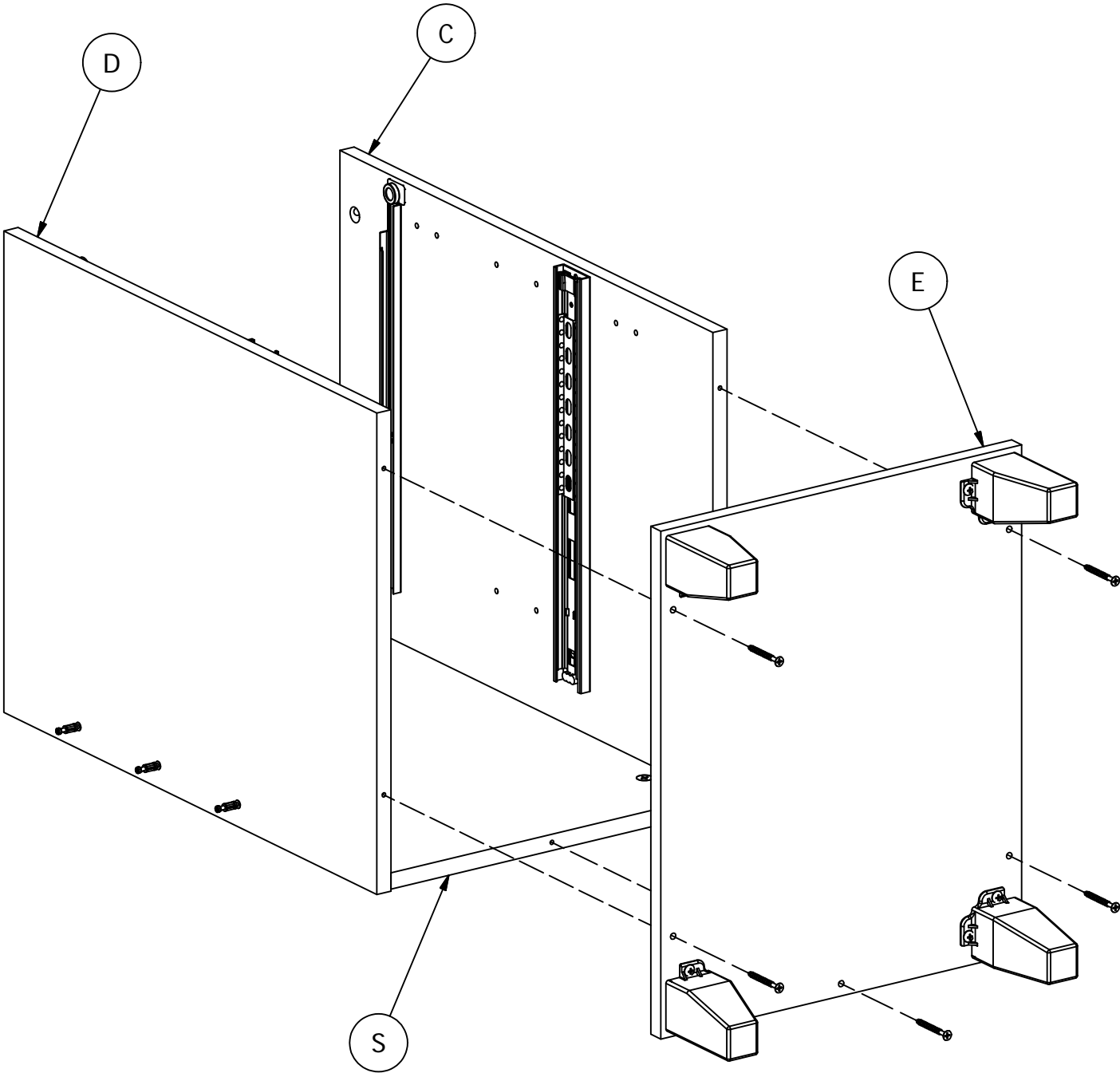

**STEP 18**

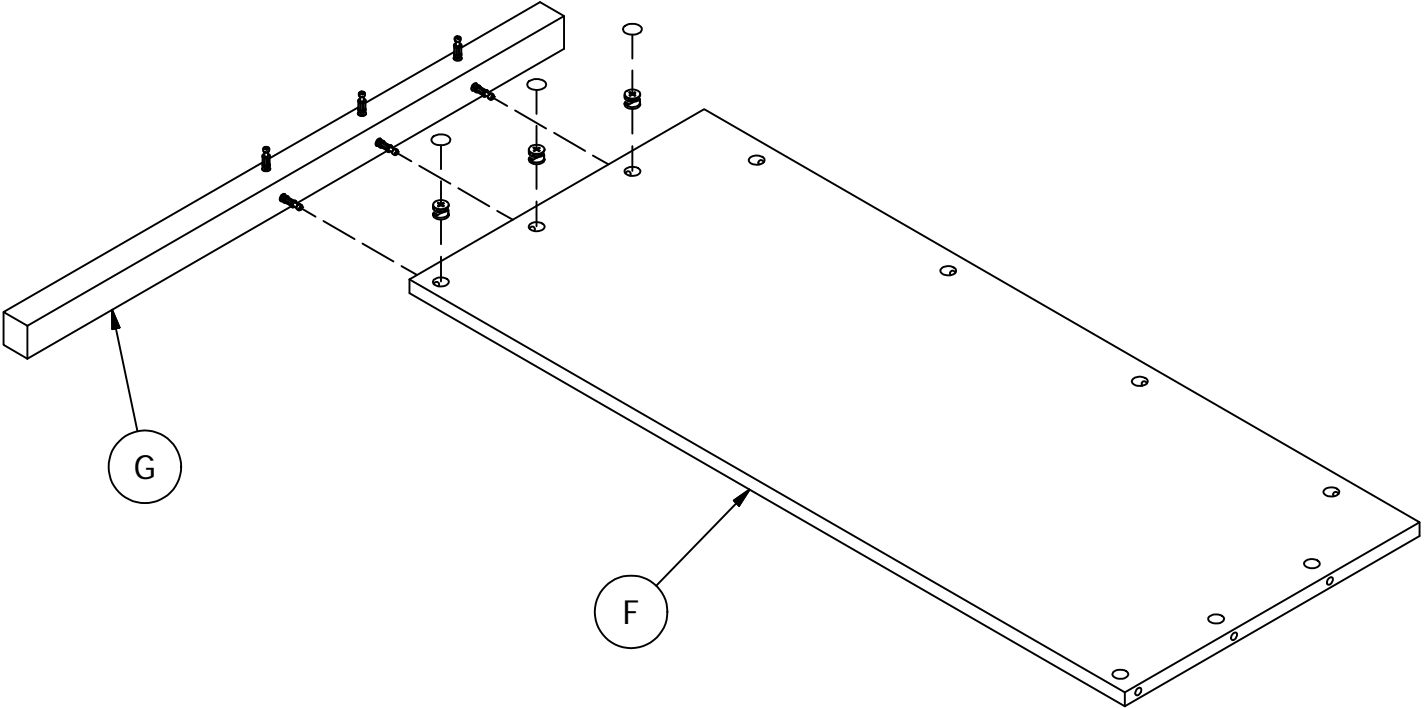
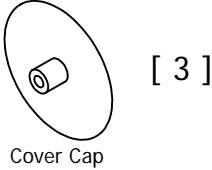
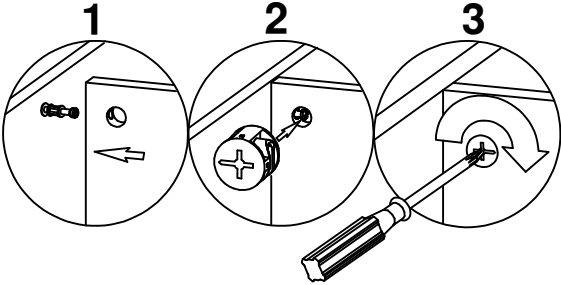
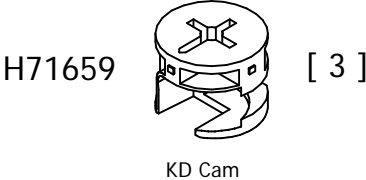

# STEP 19

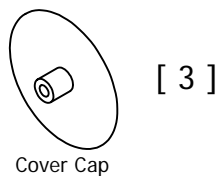
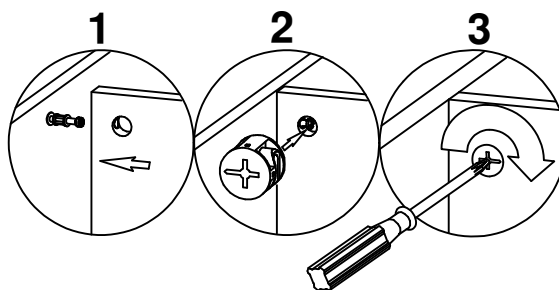
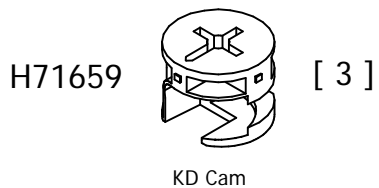

An assistant may be required.  
Un asistente puede ser necesario.  
L'aide d'une autre personne peut s'avérer nécessaire.

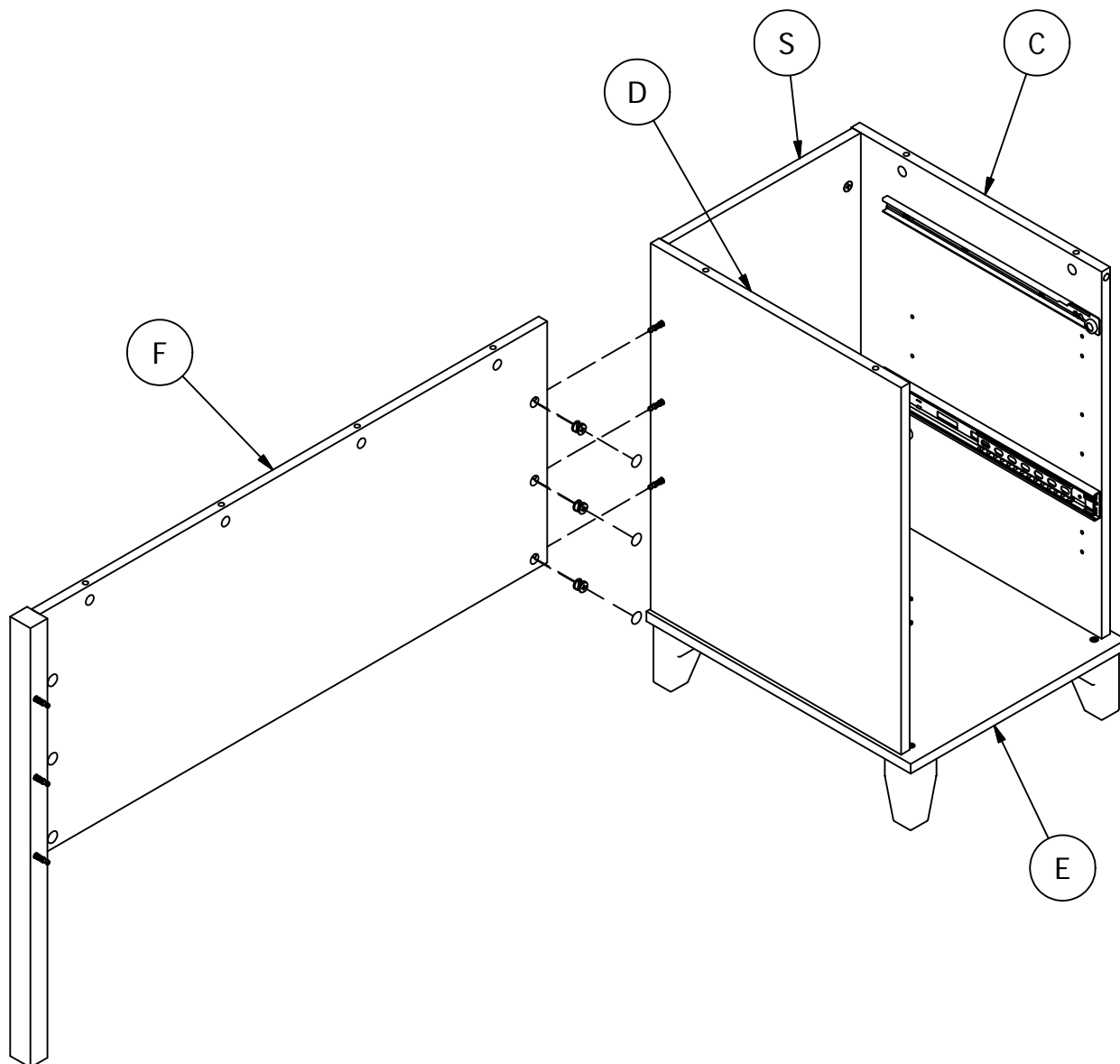

# STEP 20

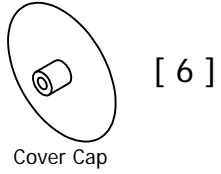
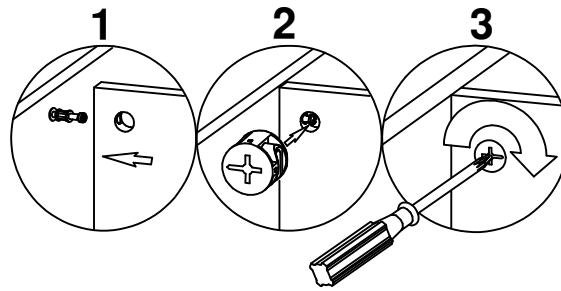
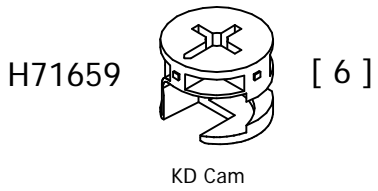

An assistant is required.  
Es necesario un ayudante.  
Un assistant est nécessaire.

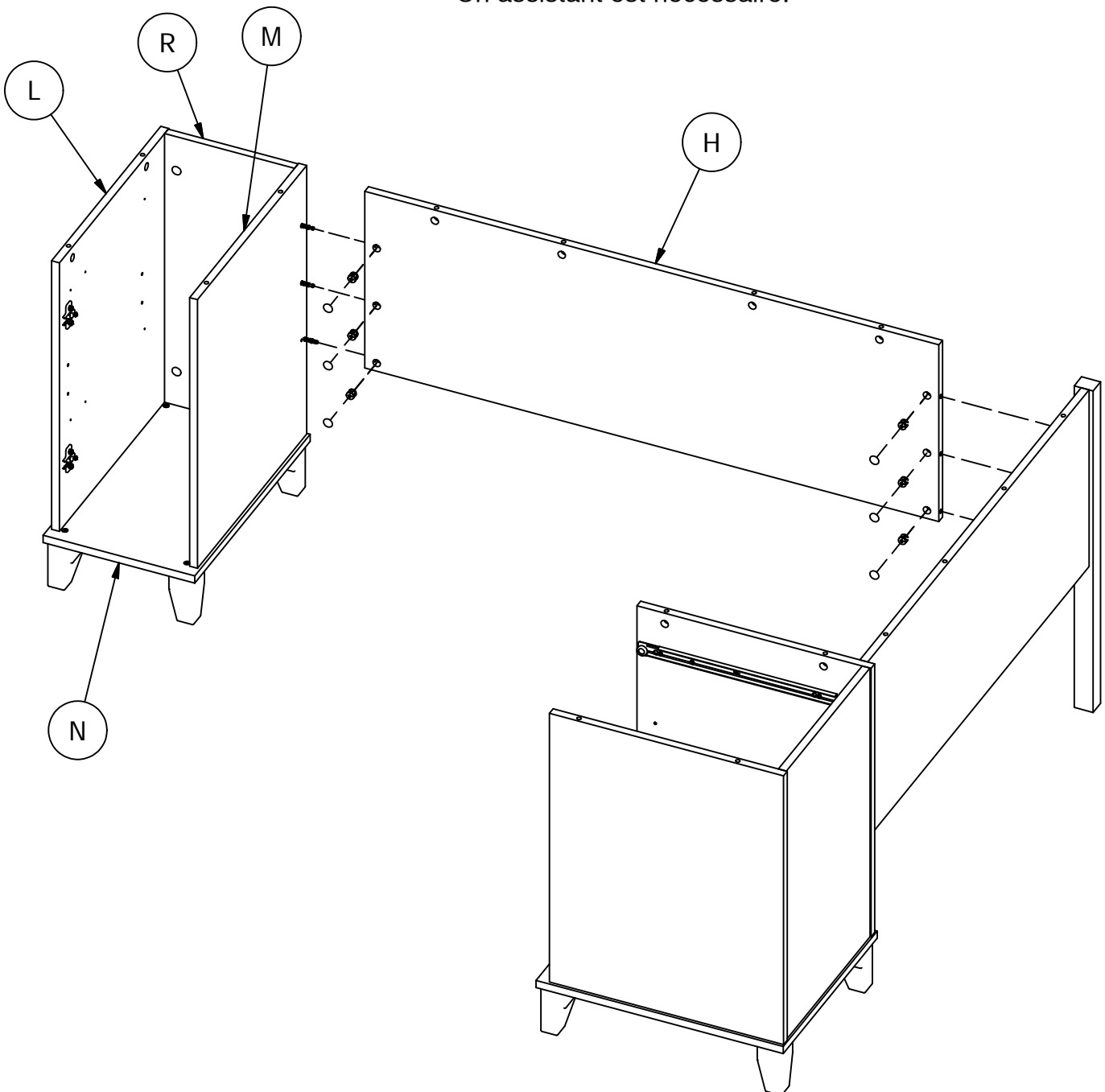

# STEP 21

H72988 [ 10 ]  
KD Bolt

H35251 [ 4 ]  
#10 x 1/2"

H39922 [ 2 ]  
Strap

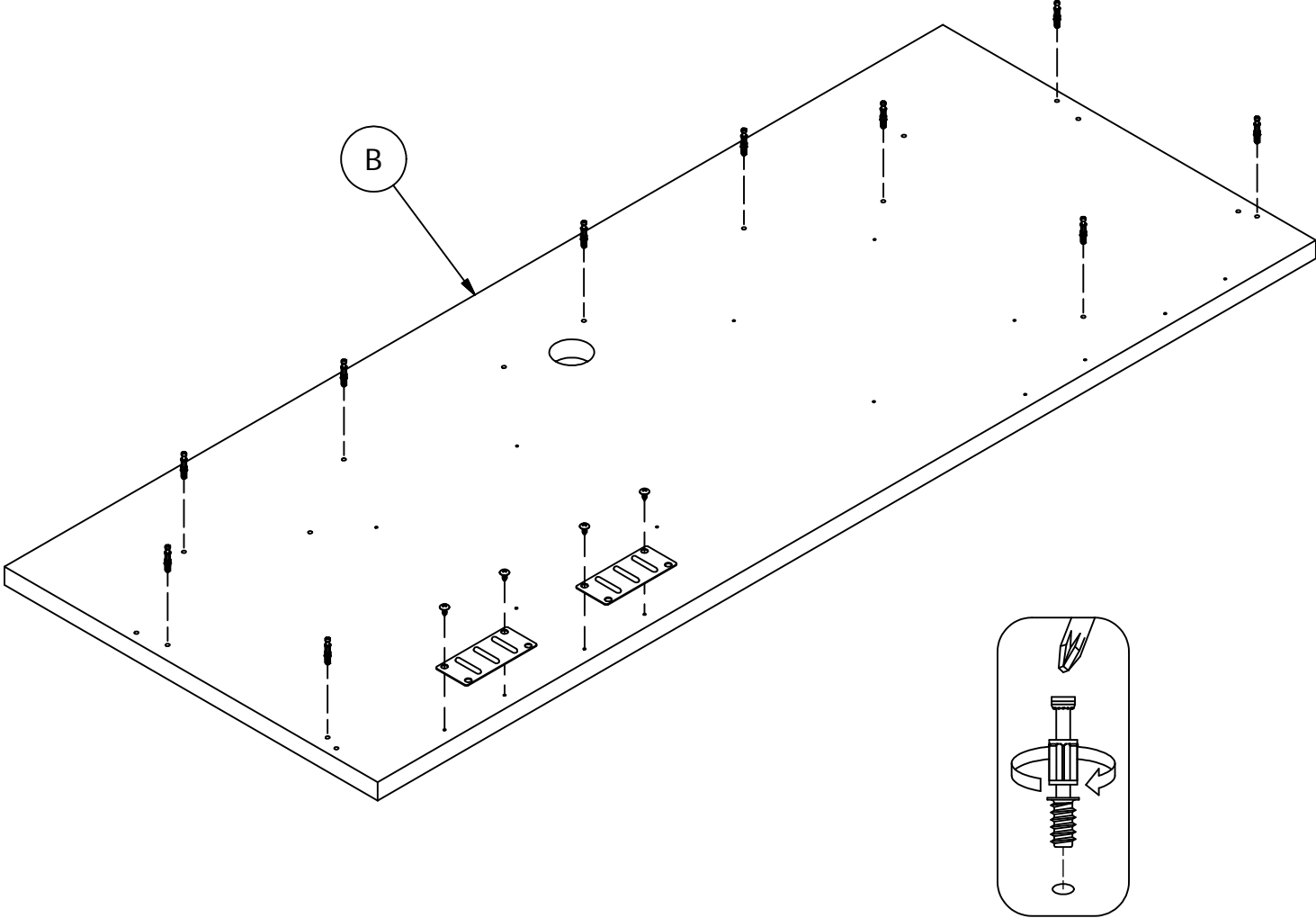

**STEP 22**

Z92806

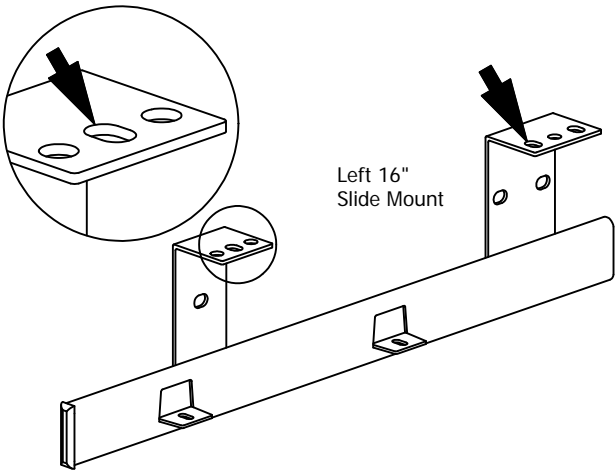

[ 1 ]

H35251

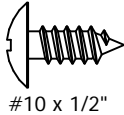

[ 4 ]

Z92807

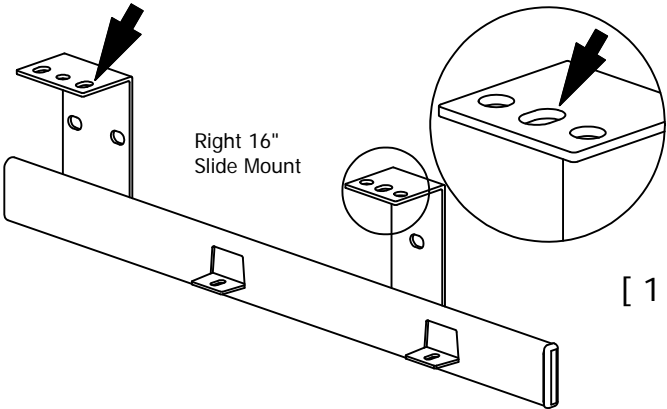

[ 1 ]

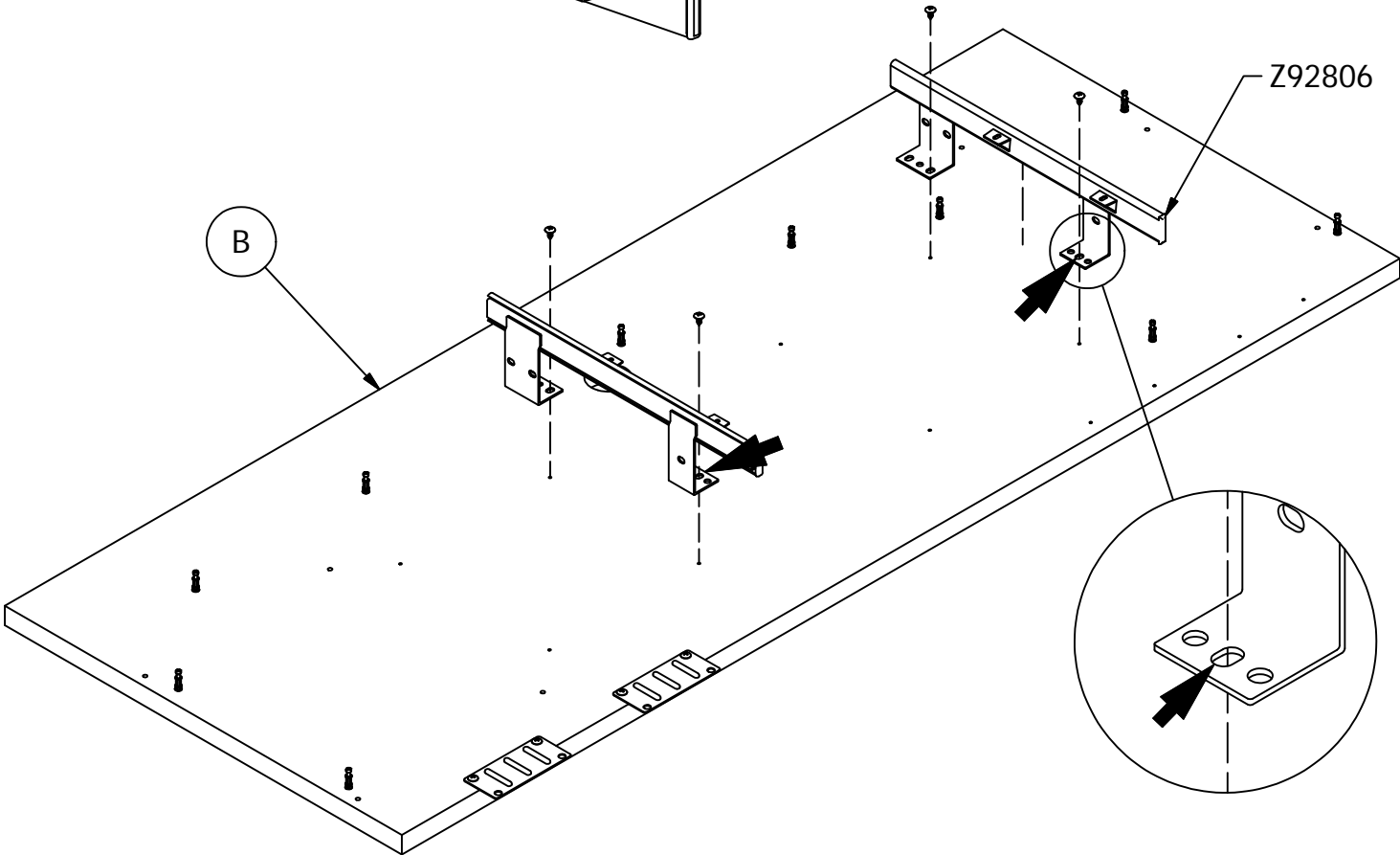

# STEP 23

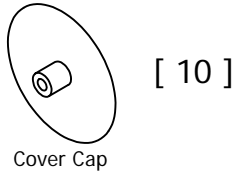
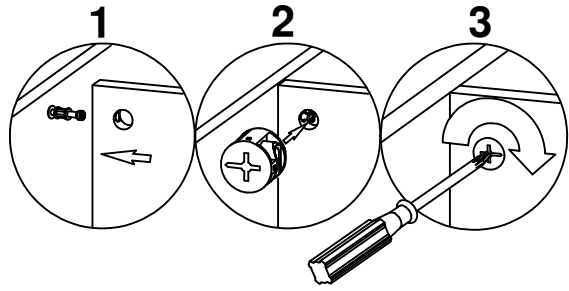
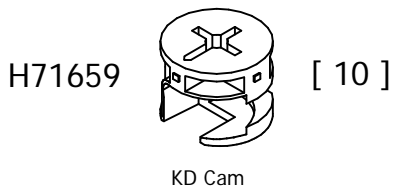

An assistant is required.  
Es necesario un ayudante.  
Un assistant est nécessaire.

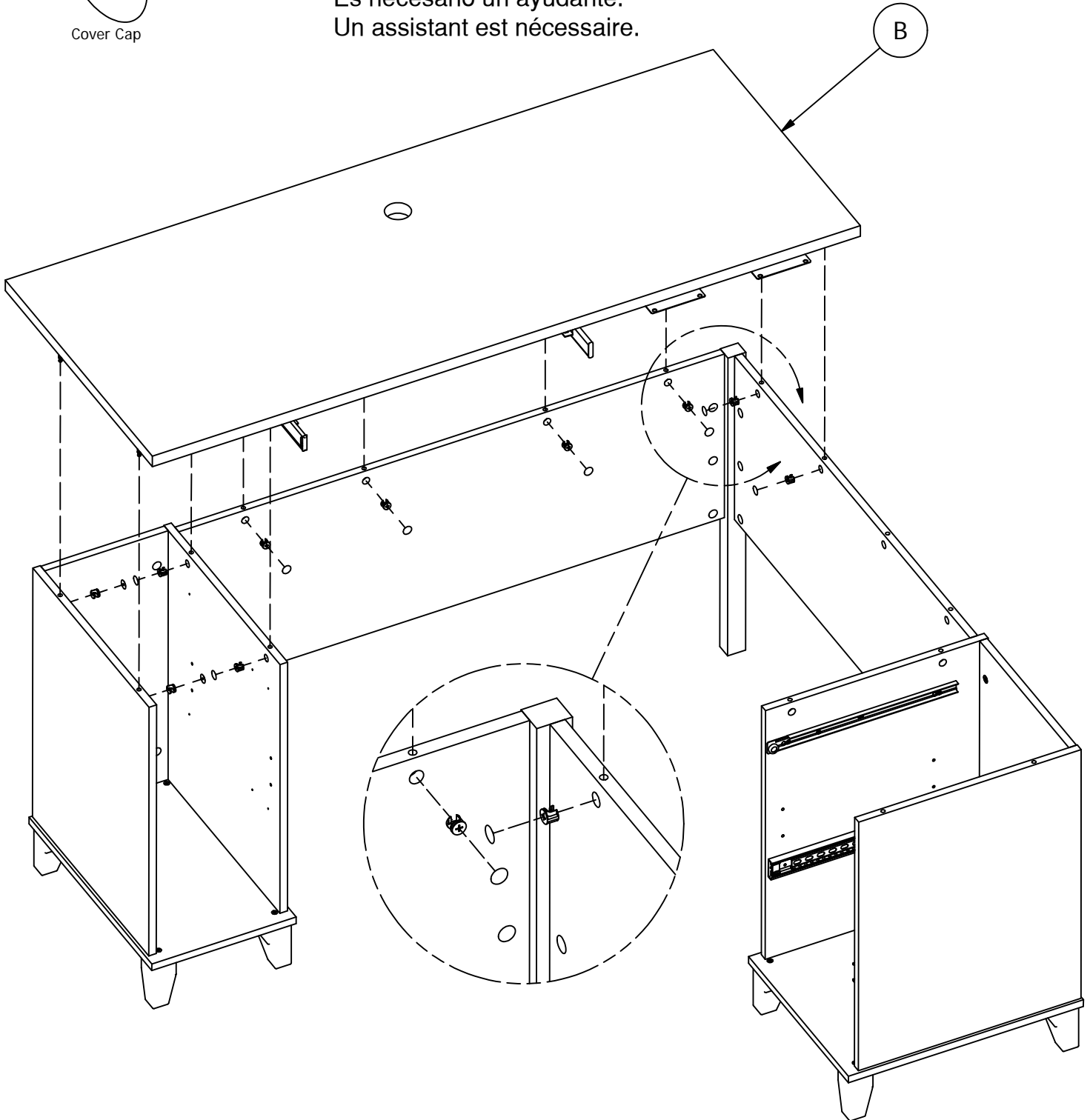

**STEP 24**

H72988

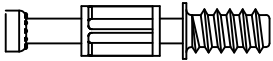

[ 6 ]

KD Bolt

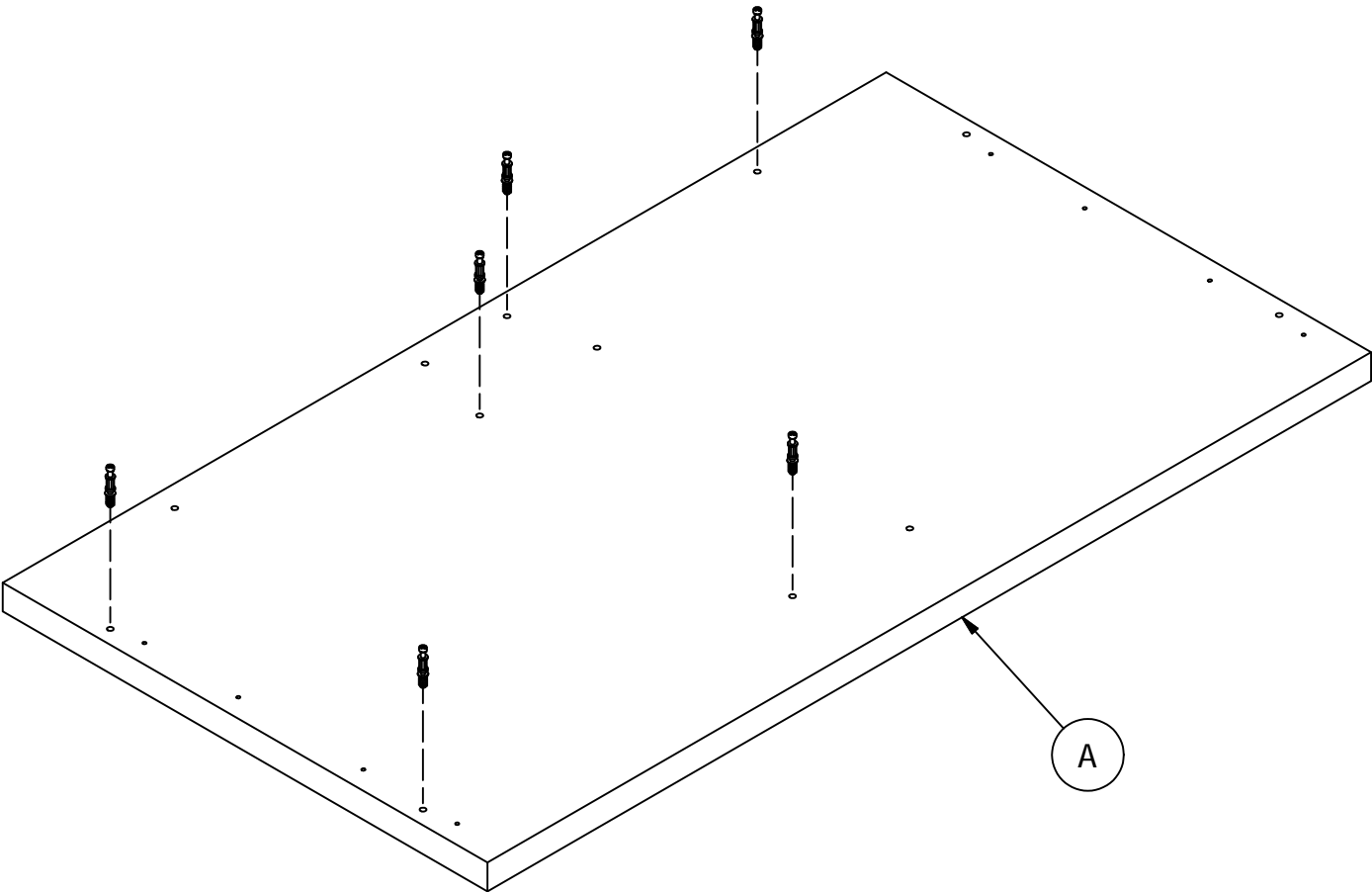
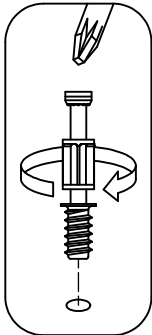

## STEP 25

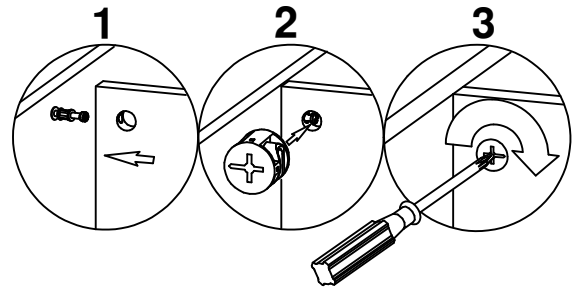
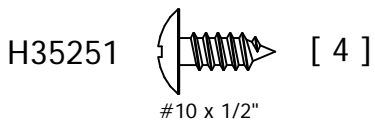
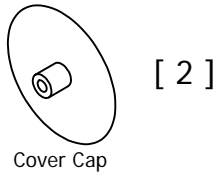
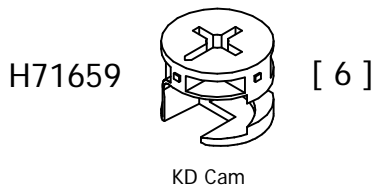

An assistant may be required.  
Un asistente puede ser necesario.  
L'aide d'une autre personne peut s'avérer nécessaire.

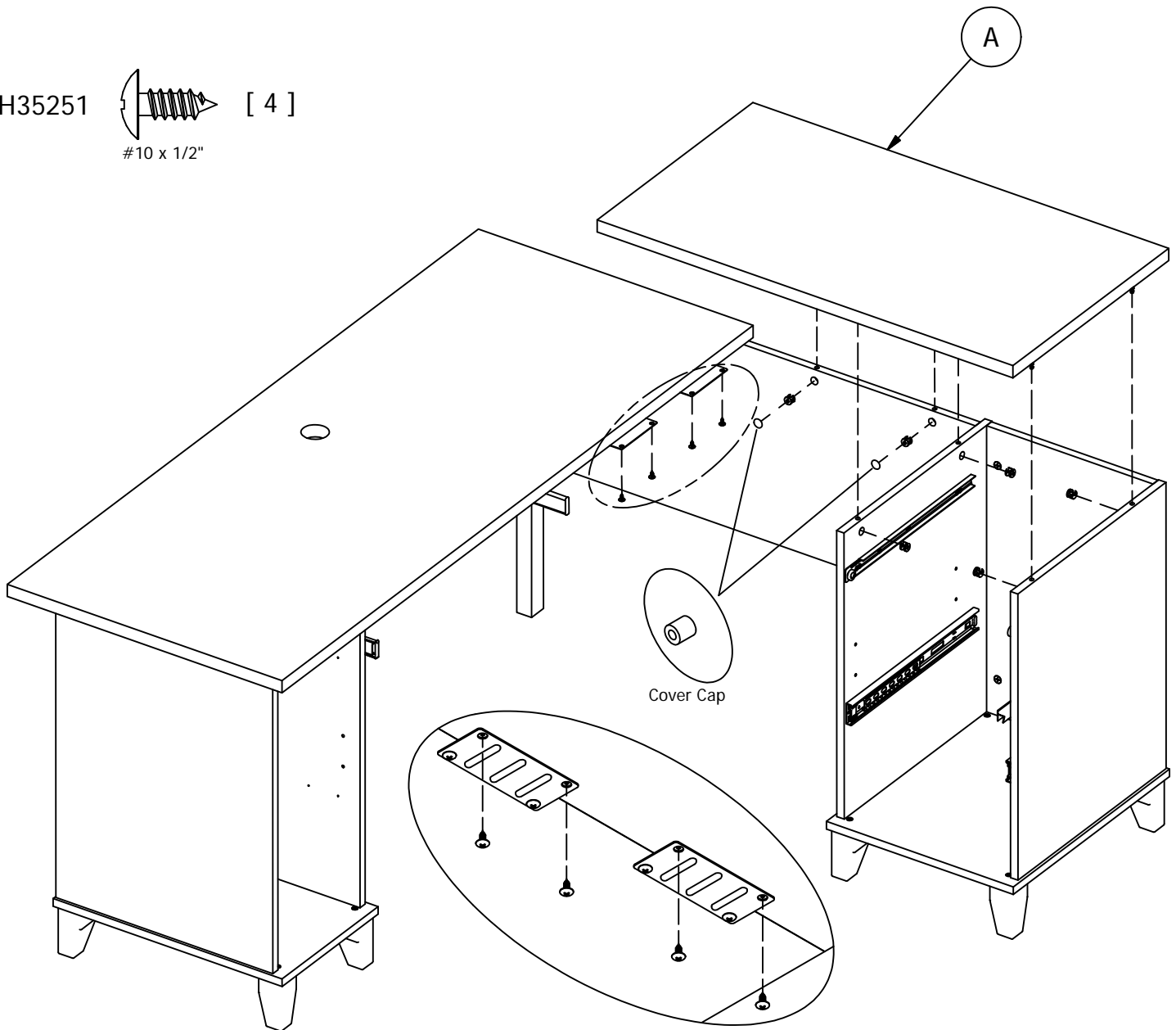

Go to Step 43 to finish Assembly  
Vaya al paso 43 para terminar el ensamblaje  
Passez à l'étape 43 pour terminer l'assemblage

# STEP 26

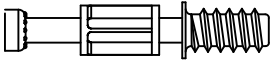
H72988  [ 7 ]  
KD Bolt

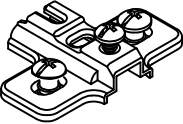
H126364  [ 2 ]  
Mounting Plate

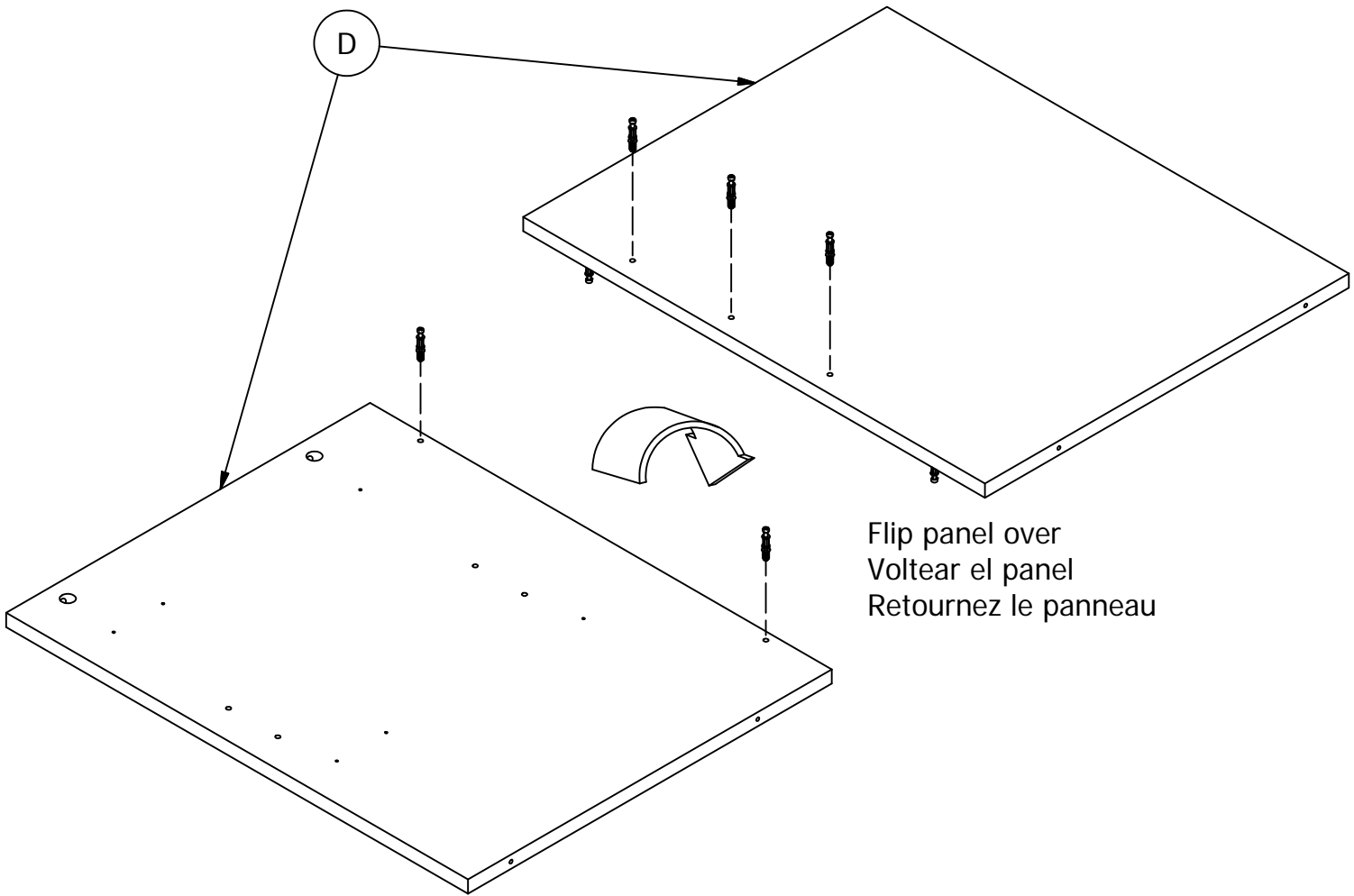
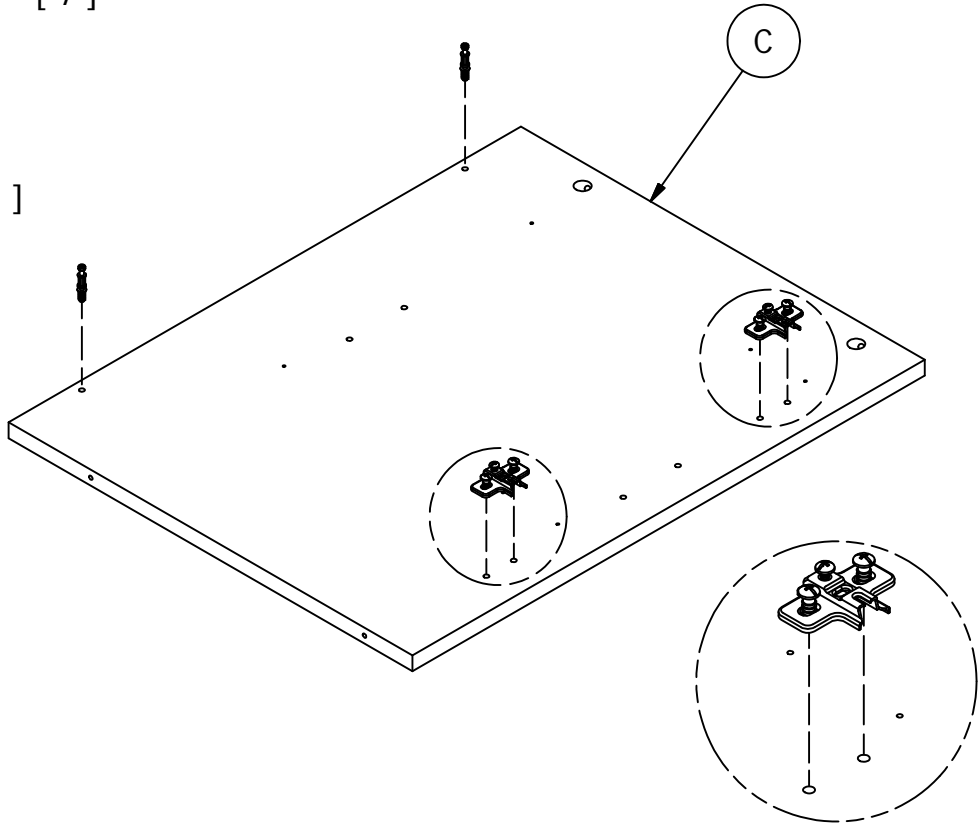
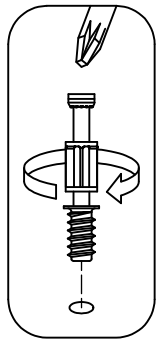

Flip panel over  
Voltear el panel  
Retournez le panneau

**STEP 27**

H71659

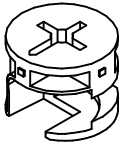

KD Cam

[ 4 ]

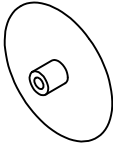
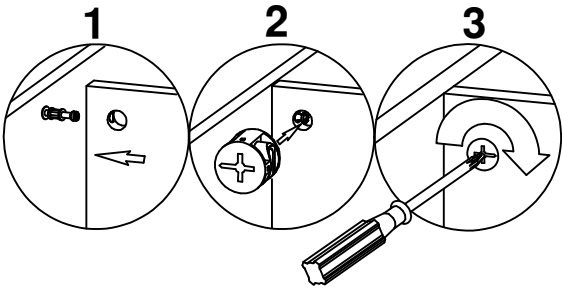

Cover Cap

[ 4 ]

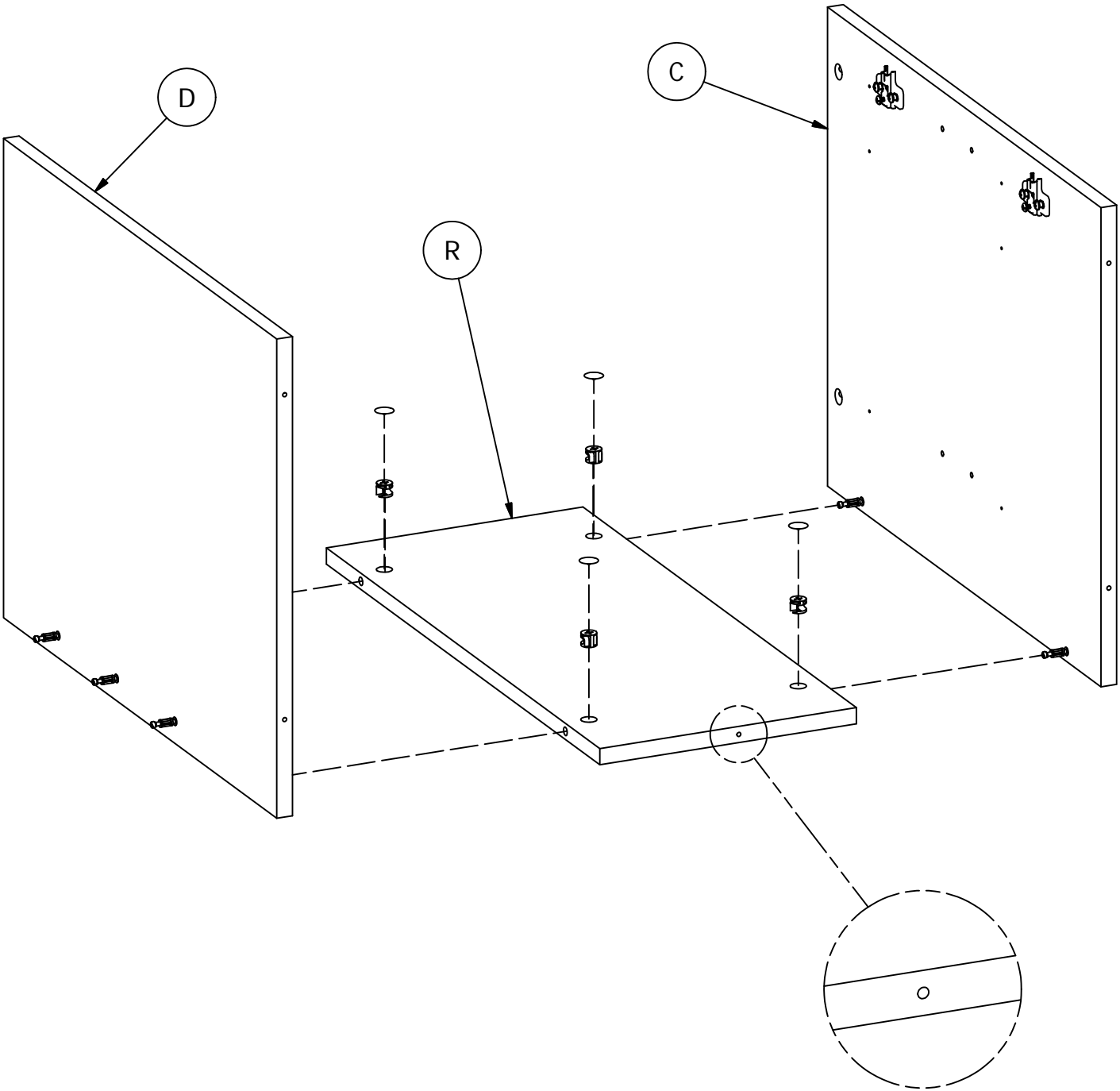

# STEP 28

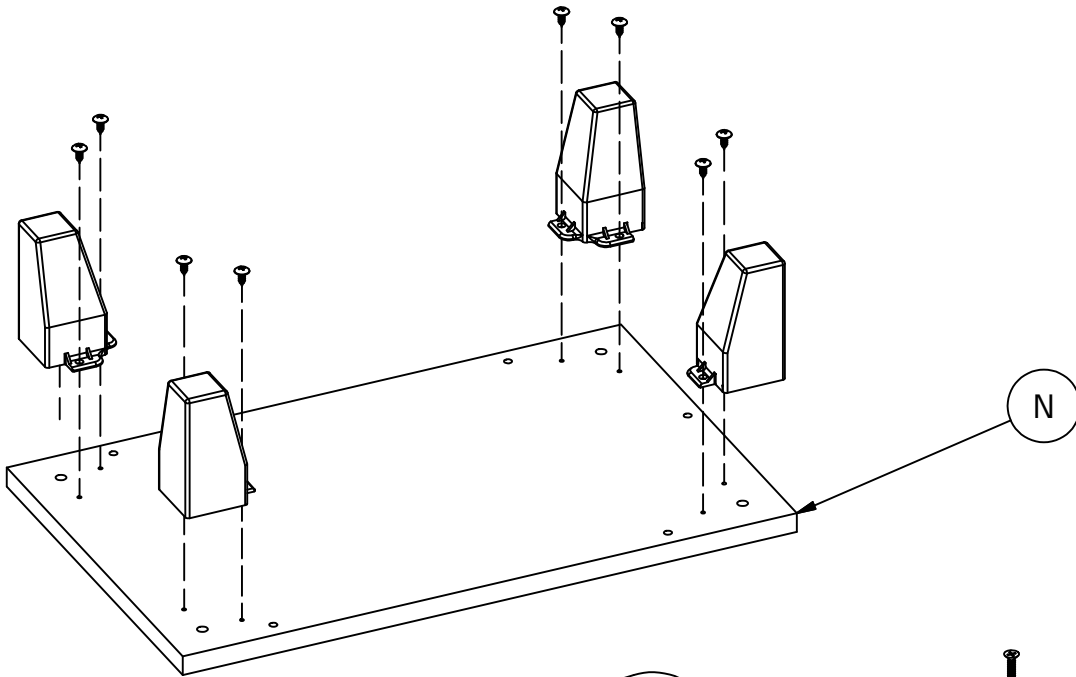
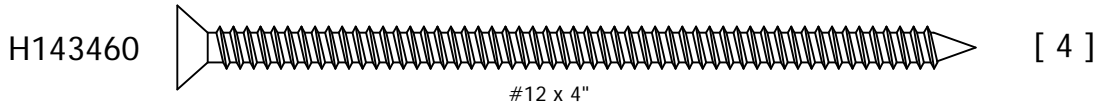

Flip panel over  
Voltar el panel  
Retournez le panneau

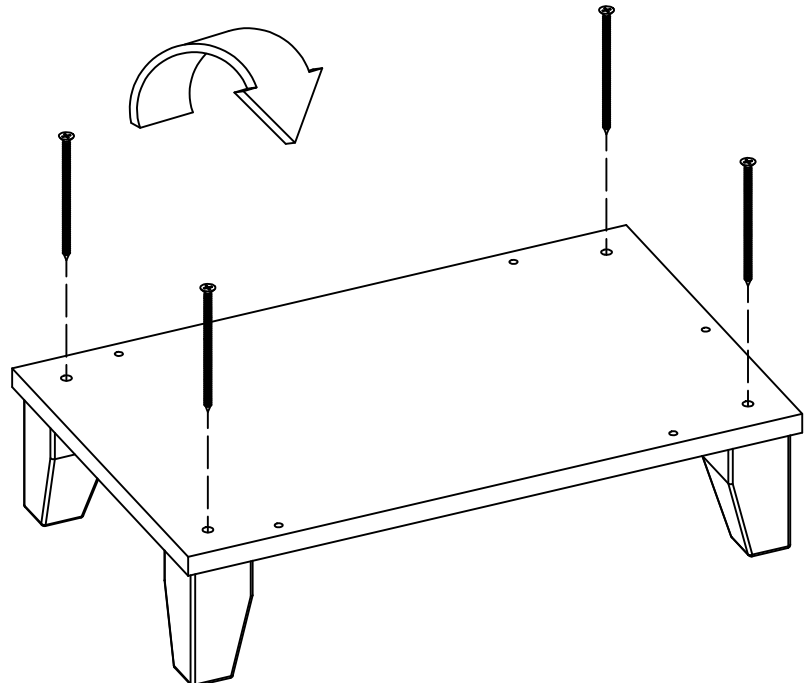

**STEP 29**

H23491

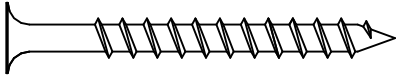

[ 5 ]

#10 x 2"

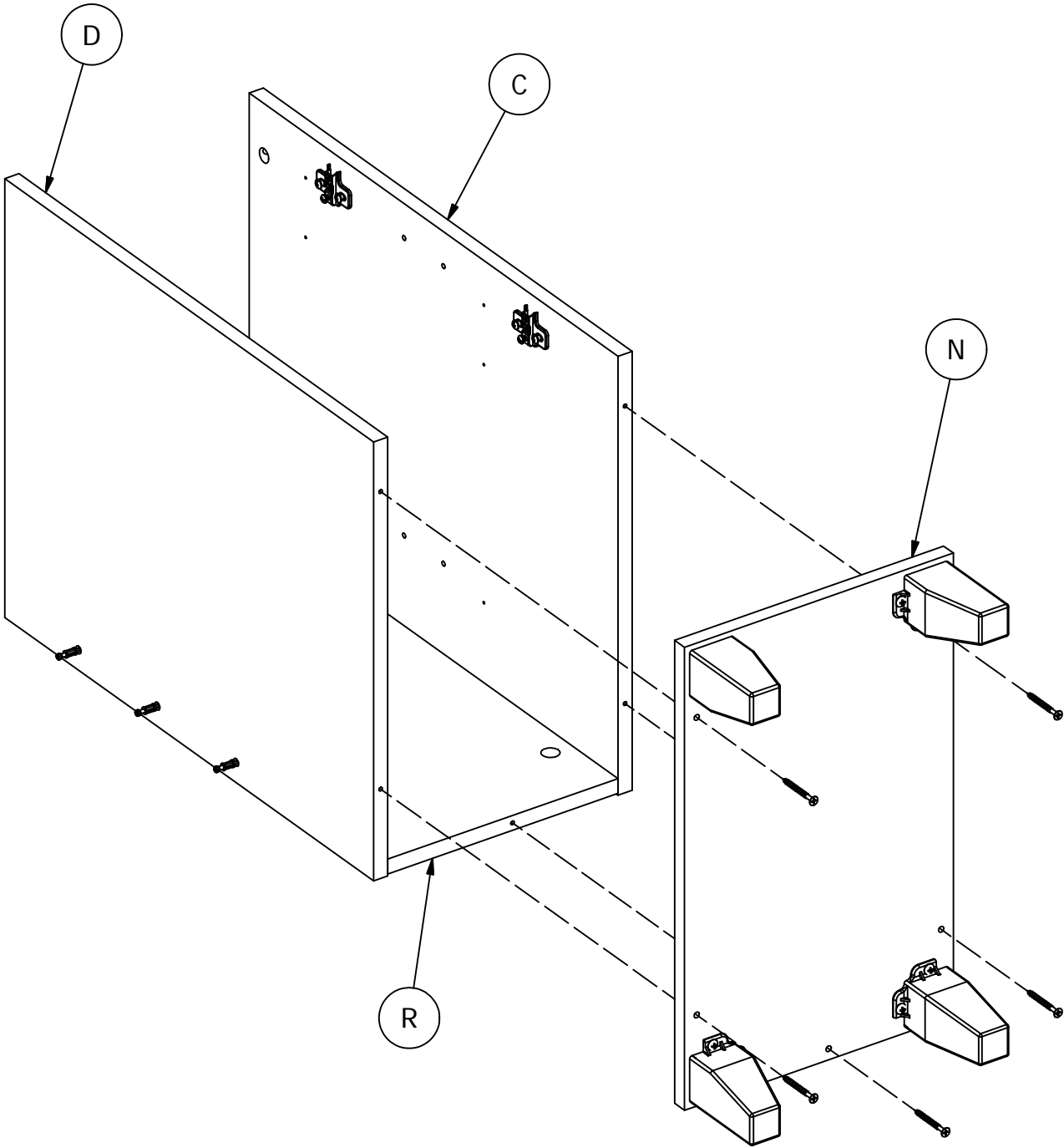

# STEP 30

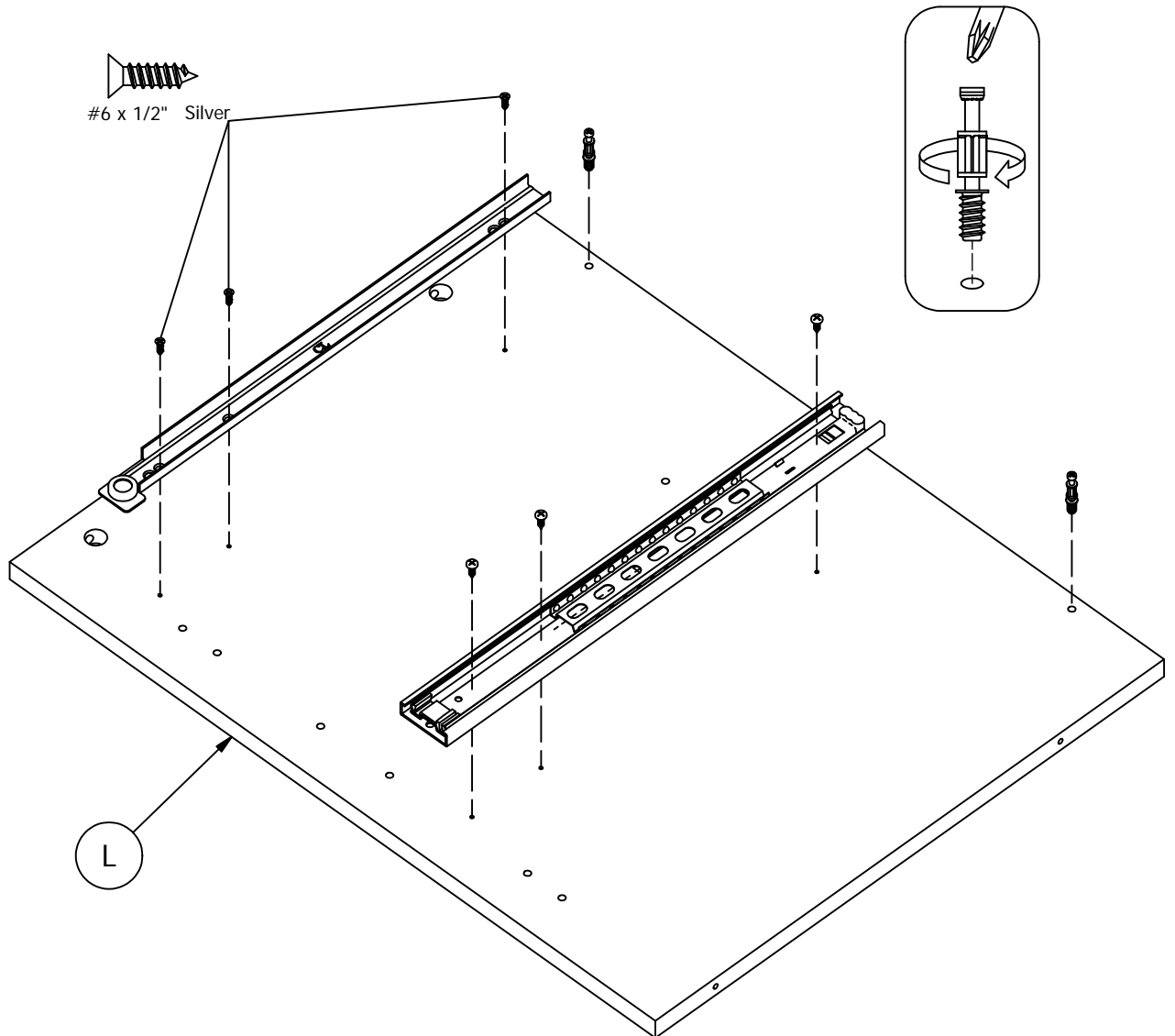
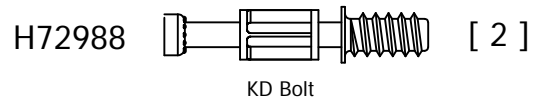
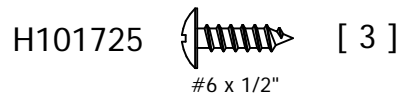
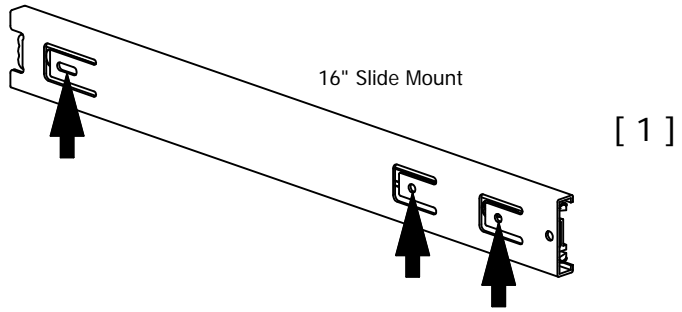
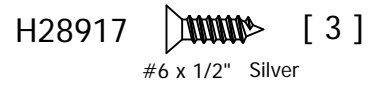
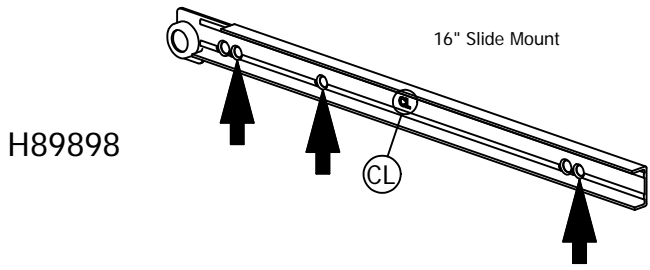

# STEP 31

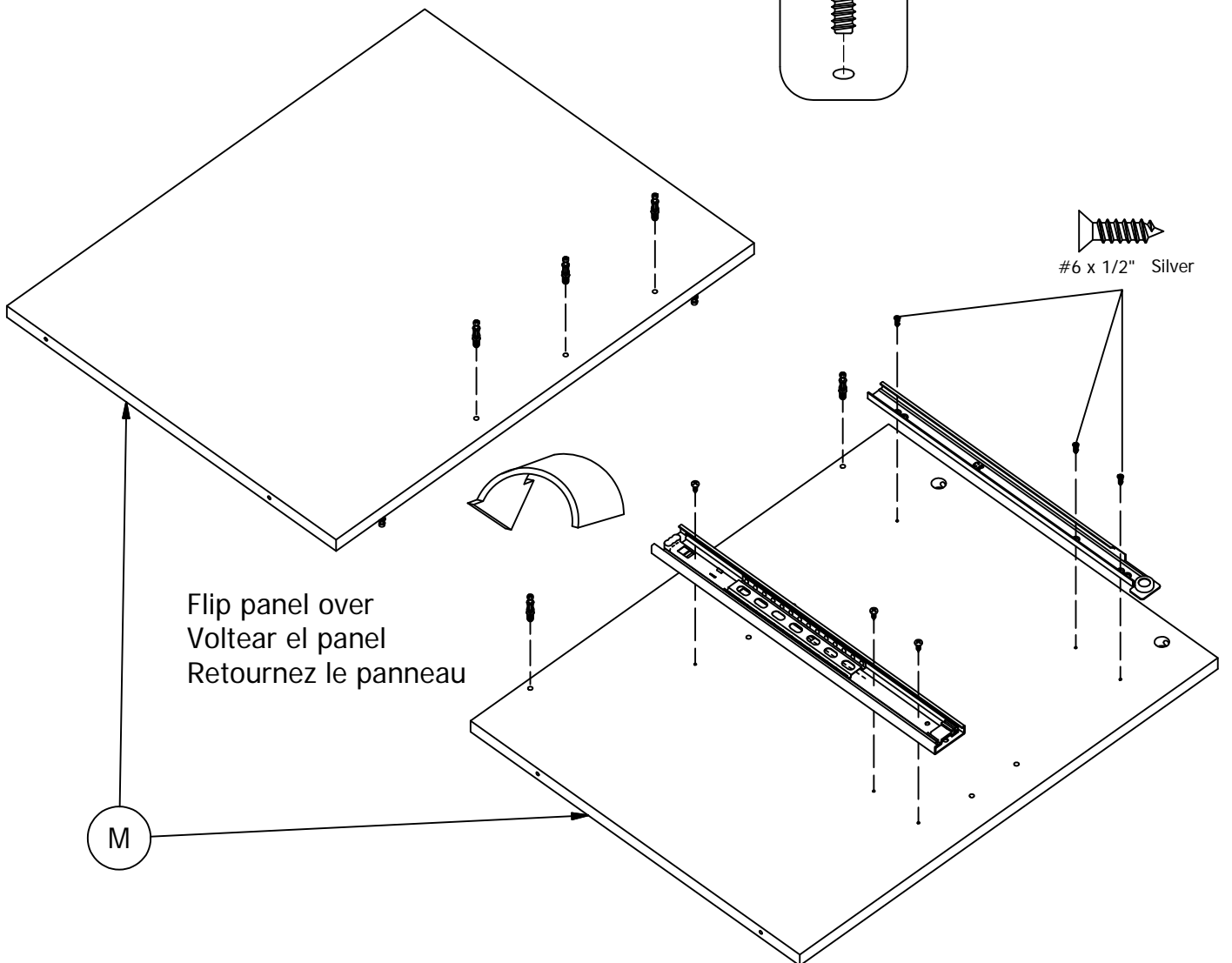
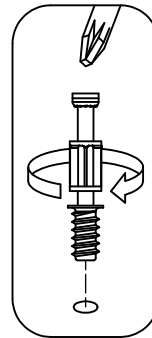
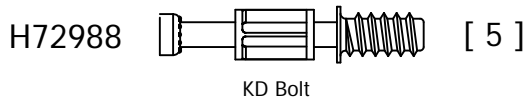
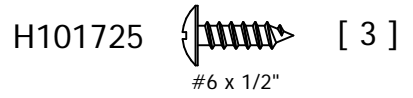
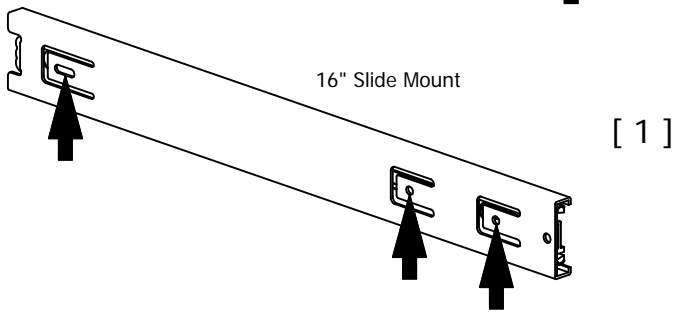
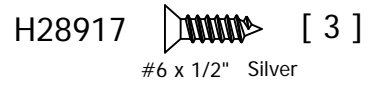
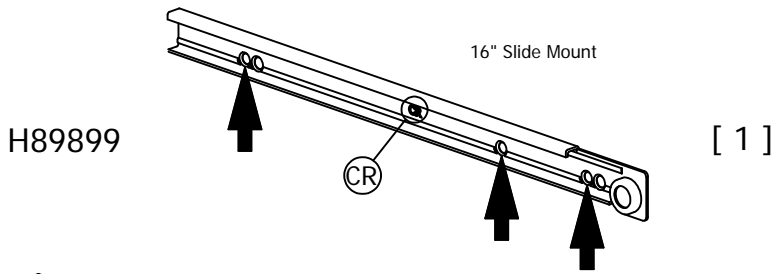

**STEP 32**

H71659

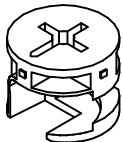

[ 4 ]

KD Cam

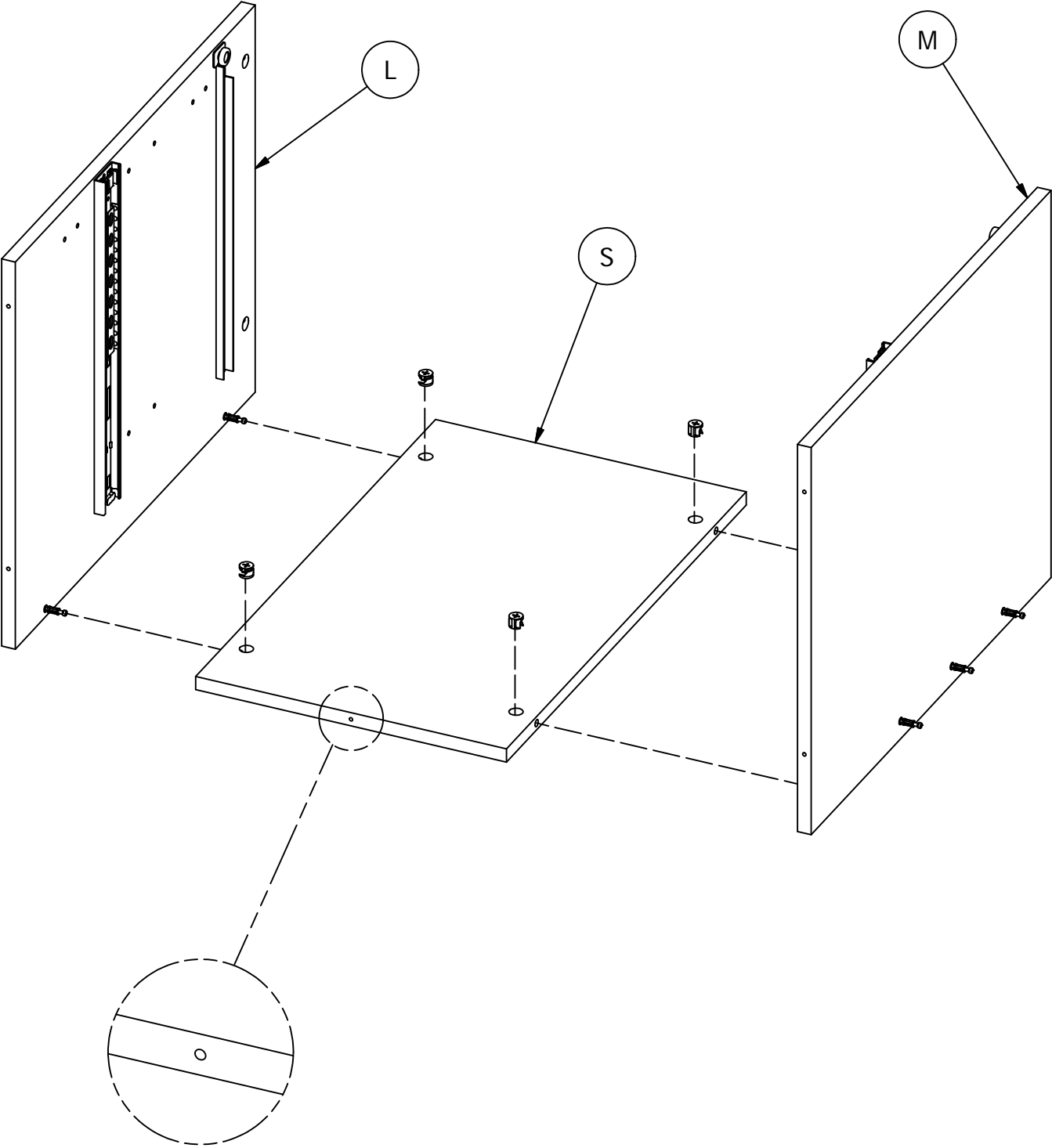

**STEP 33**

H143460

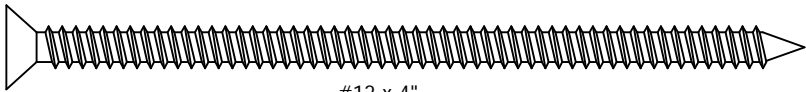

[ 4 ]

#12 x 4"

H35251

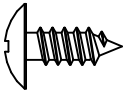

[ 8 ]

#10 x 1/2"

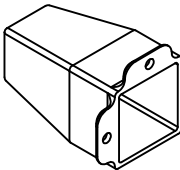

[ 4 ]

Foot

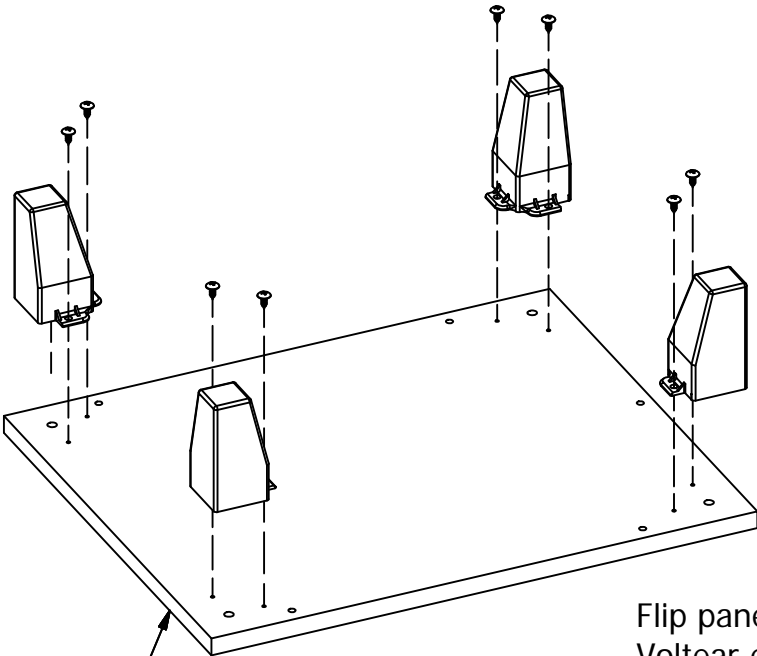

Flip panel over  
Voltear el panel  
Retournez le panneau

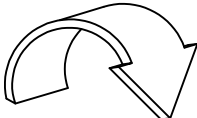

E

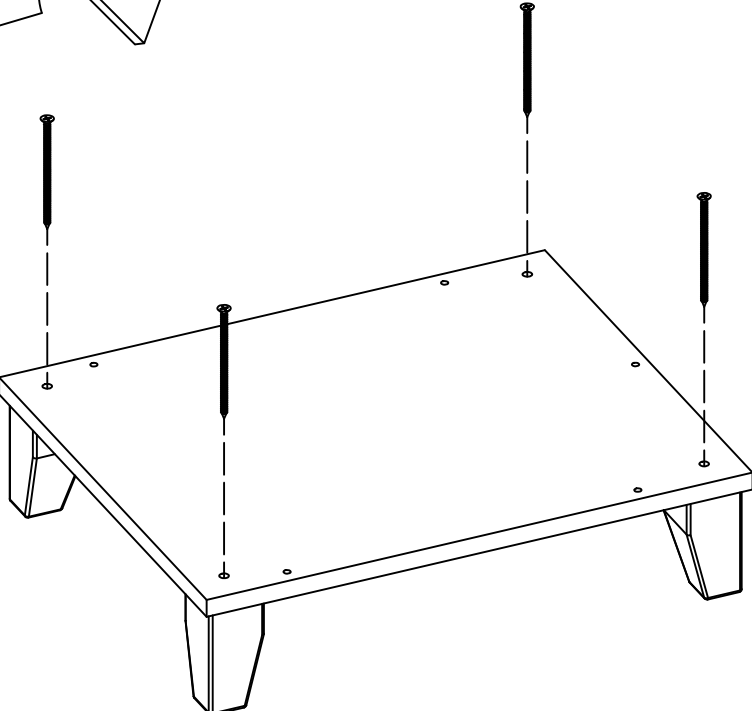

**STEP 34**

H23491

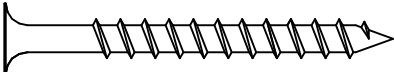

[ 5 ]

#10 x 2"

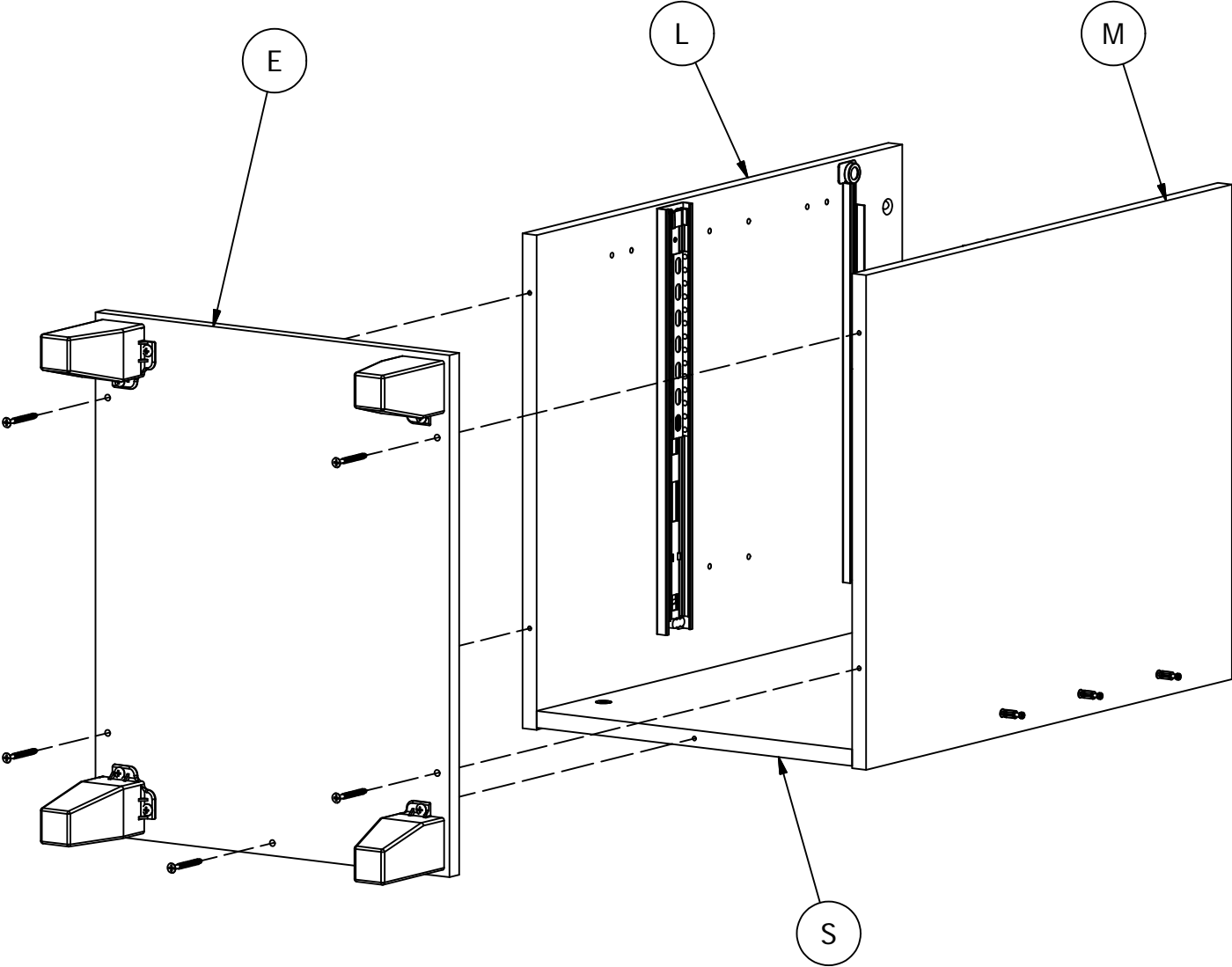

**STEP 35**

H71659

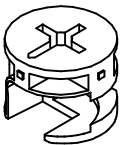

[ 3 ]

KD Cam

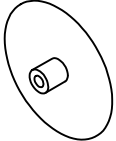
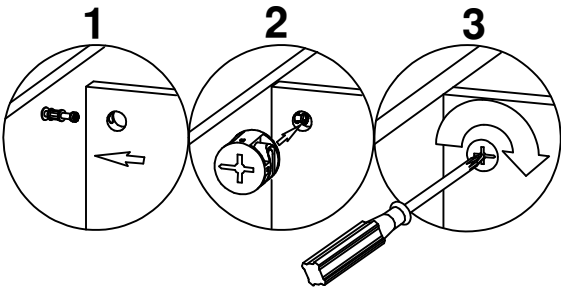

[ 3 ]

Cover Cap

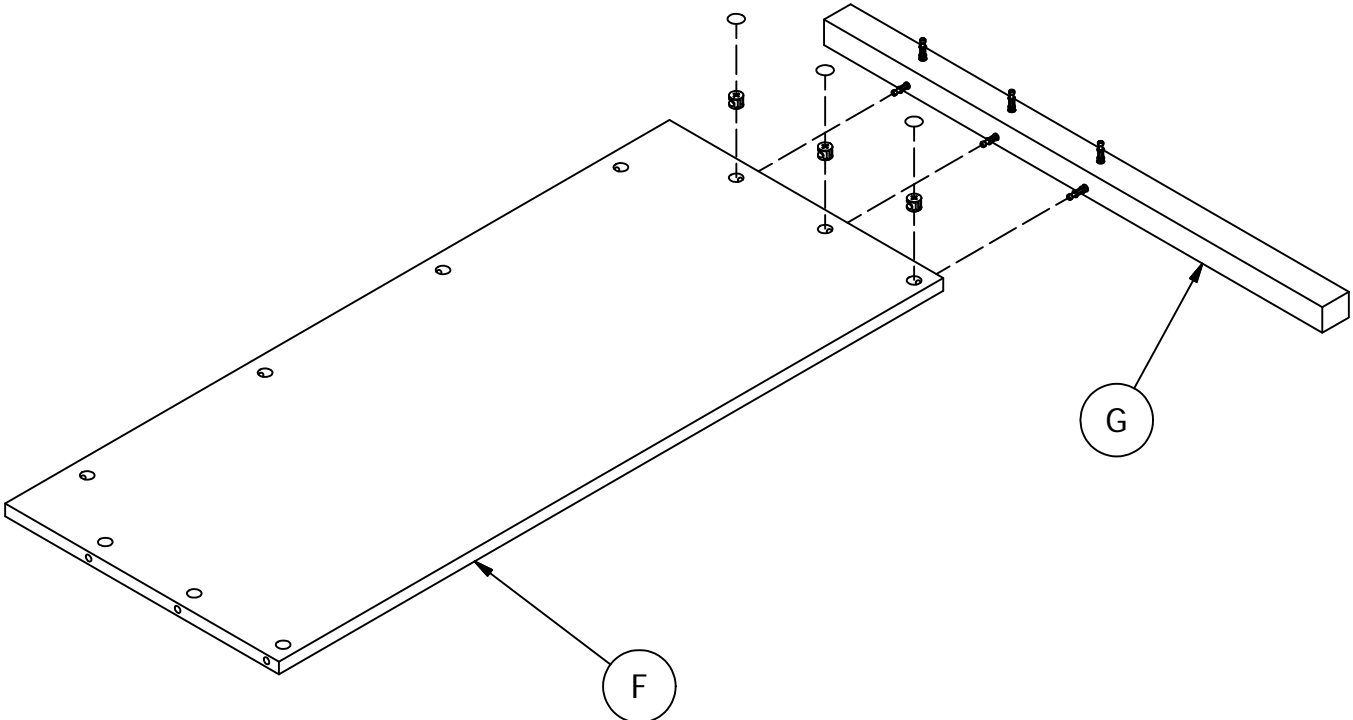

# STEP 36

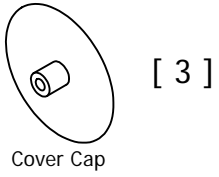
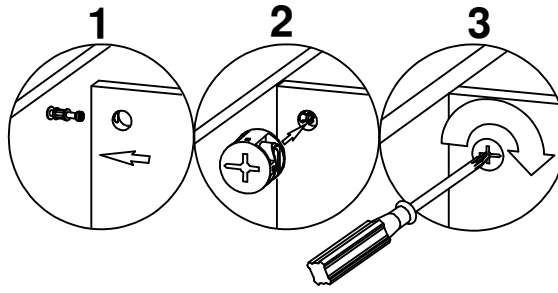
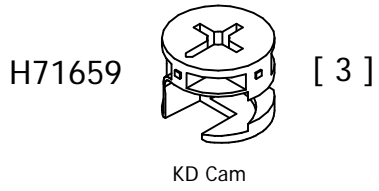

An assistant may be required.  
Un asistente puede ser necesario.  
L'aide d'une autre personne peut s'avérer nécessaire.

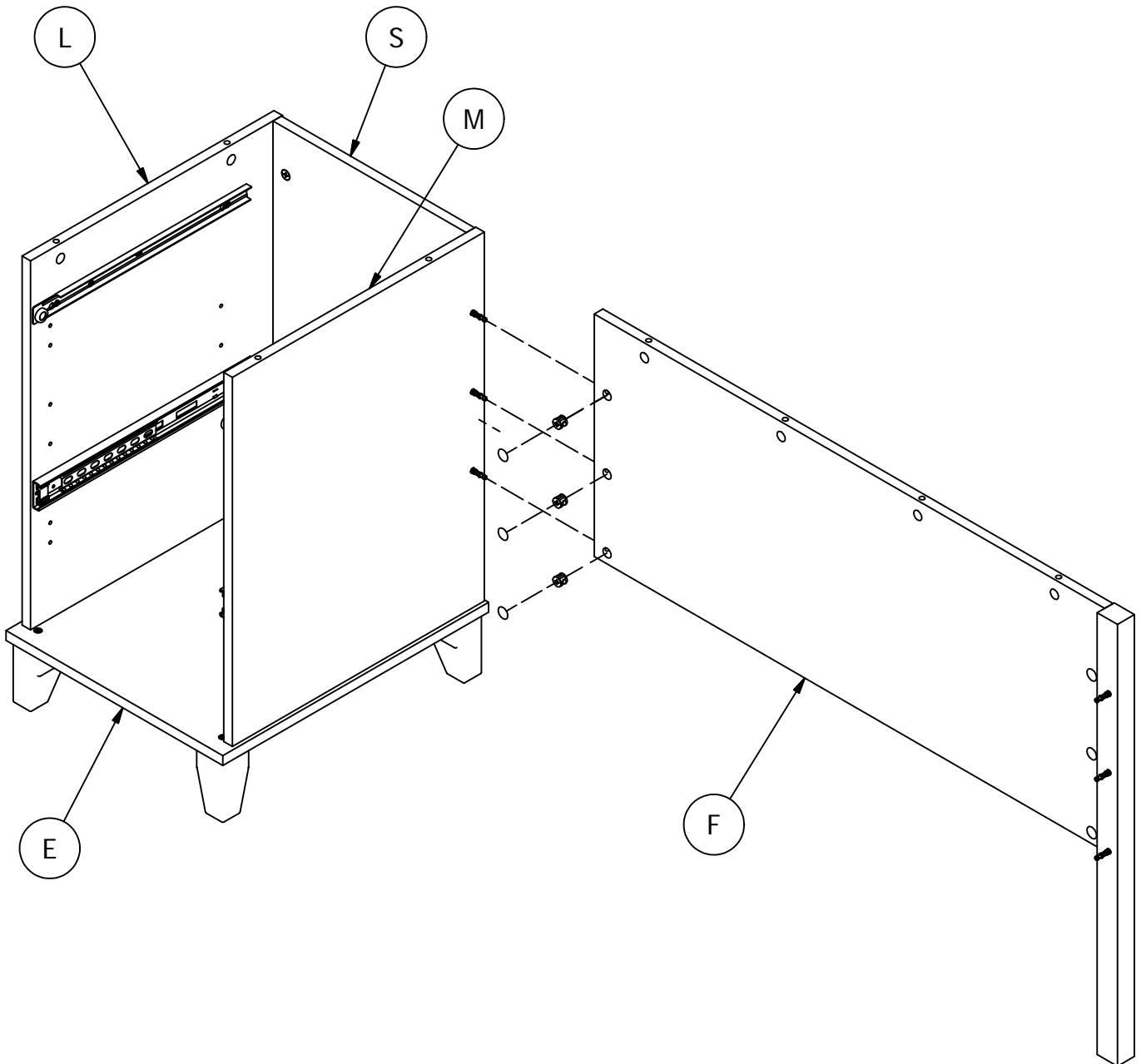

# STEP 37

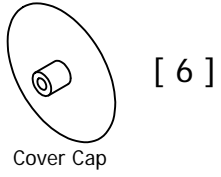
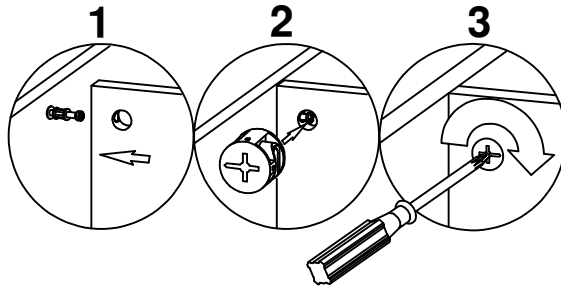
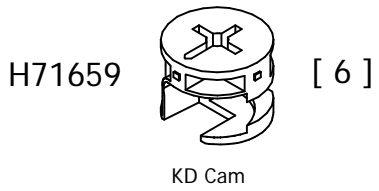

An assistant is required.  
Es necesario un ayudante.  
Un assistant est nécessaire.

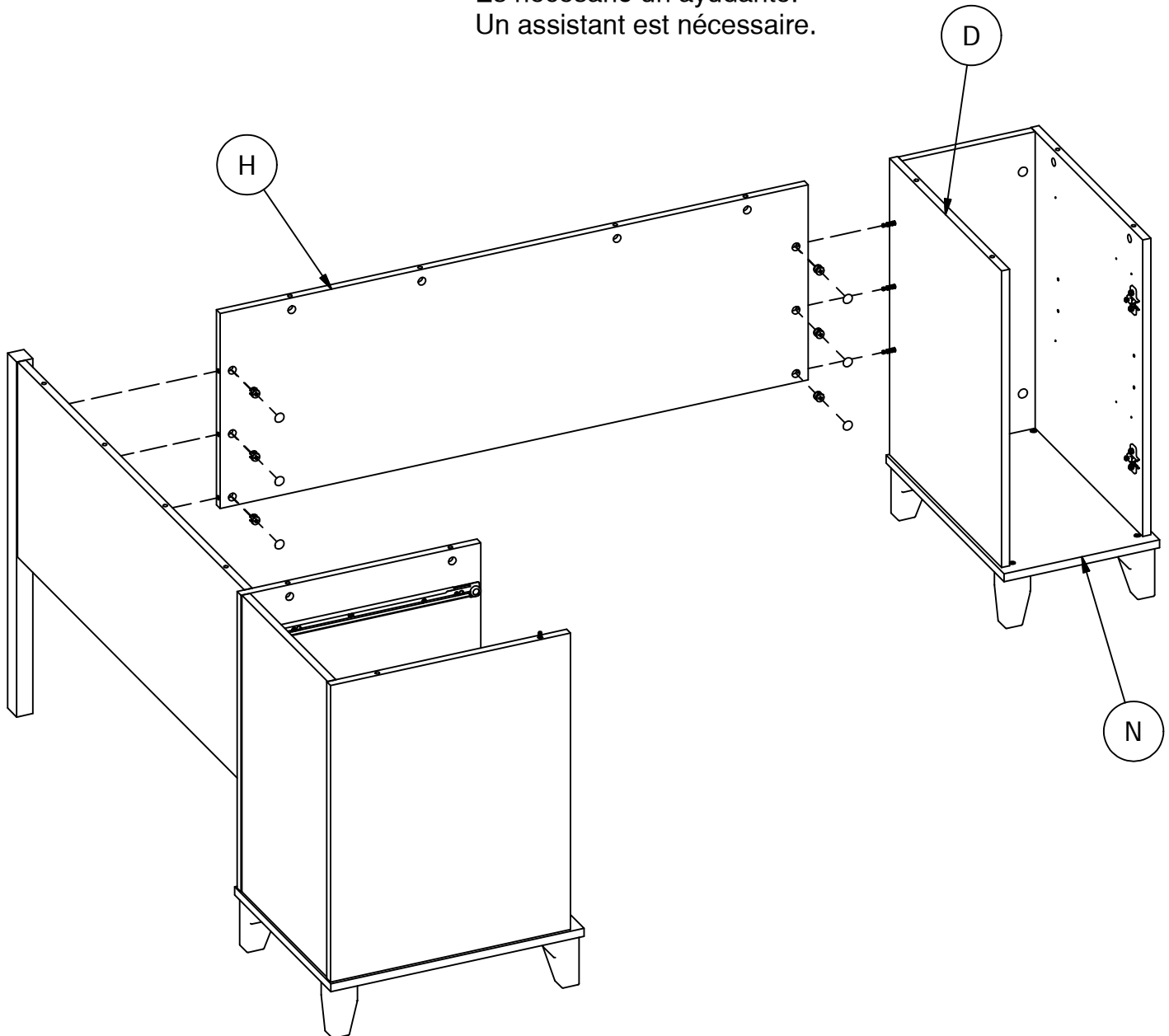

**STEP 38**

H72988

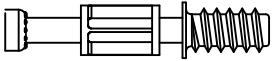

KD Bolt

[ 10 ]

H35251

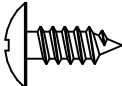

#10 x 1/2"

[ 4 ]

H39922

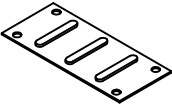

Strap

[ 2 ]

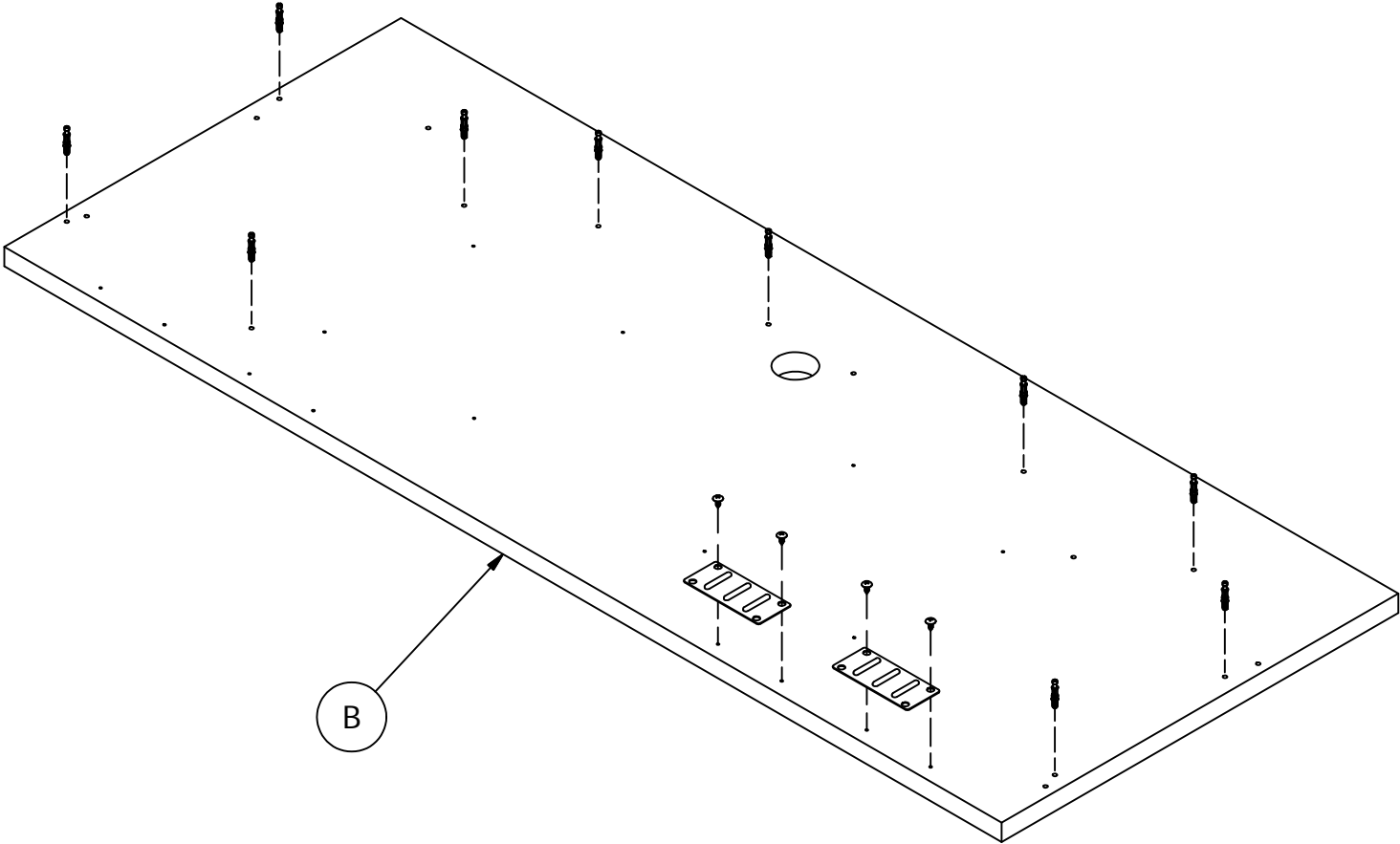
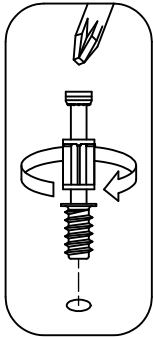

# STEP 39

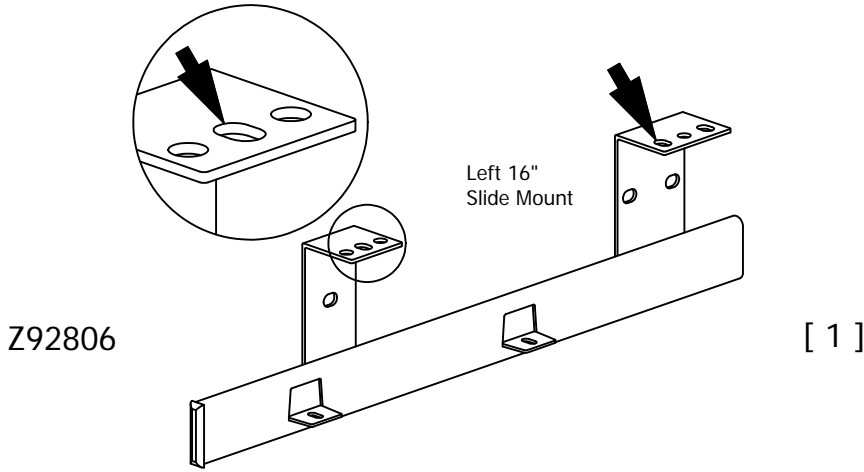

H35251 [ 4 ]

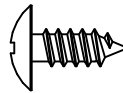

#10 x 1/2"

This block contains the part number H35251, the quantity [ 4 ], and a symbol for a screw. Below the symbol, the screw size is specified as #10 x 1/2".

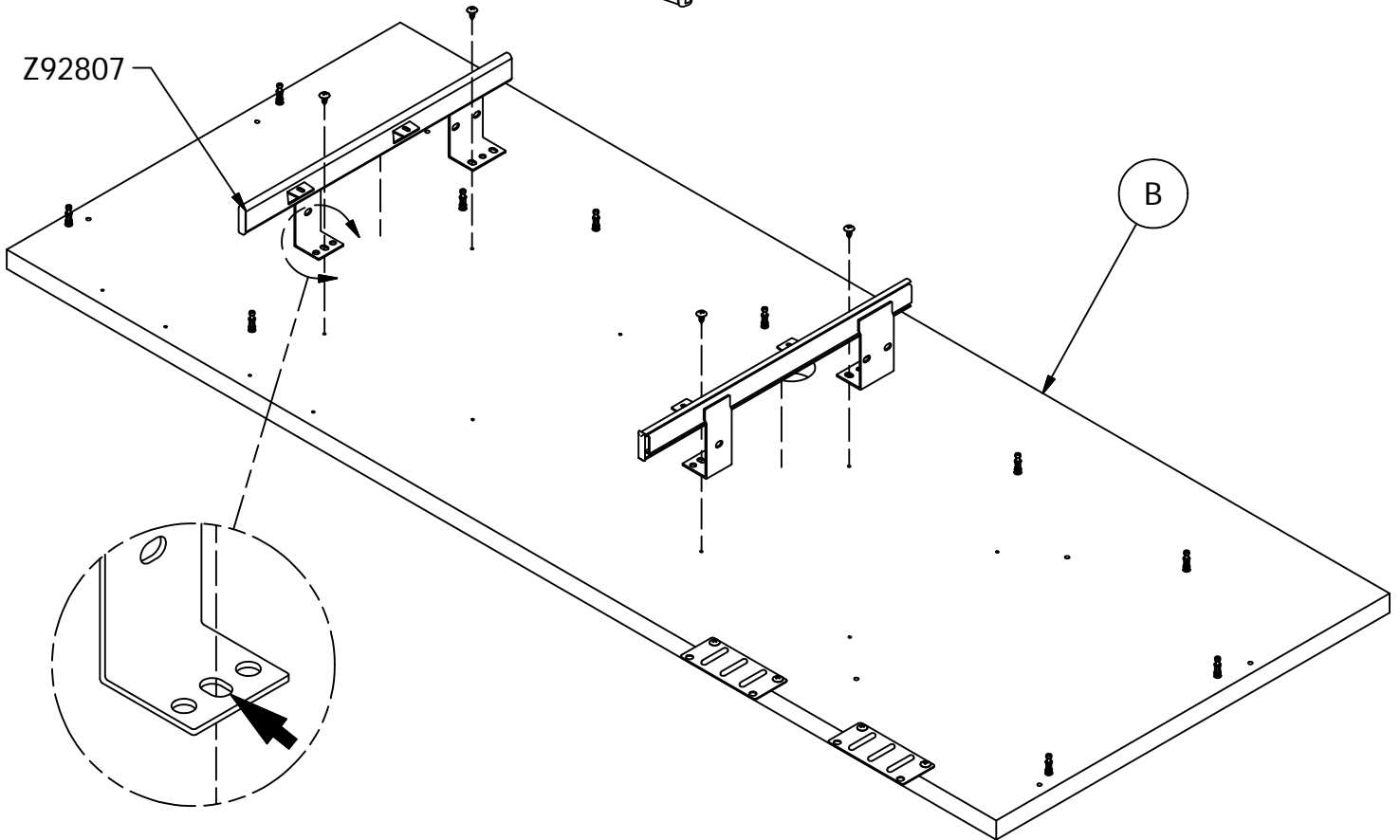
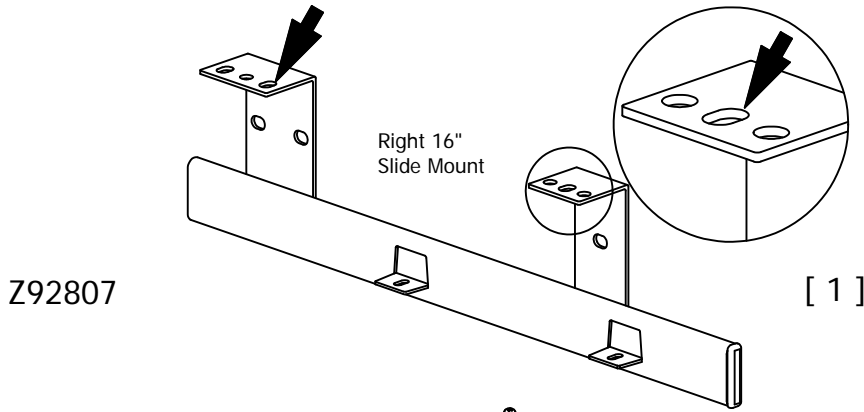

# STEP 40

H71659

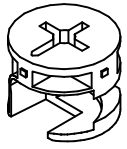

[ 10 ]

KD Cam

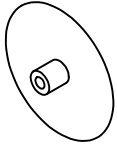
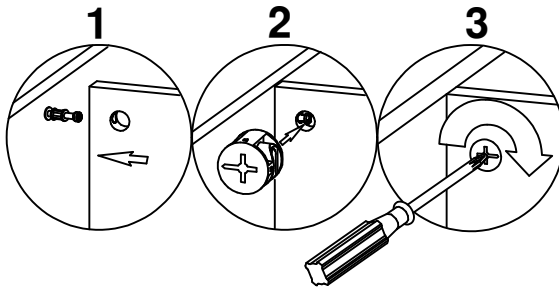

[ 10 ]

Cover Cap

An assistant is required.  
Es necesario un ayudante.  
Un assistant est nécessaire.

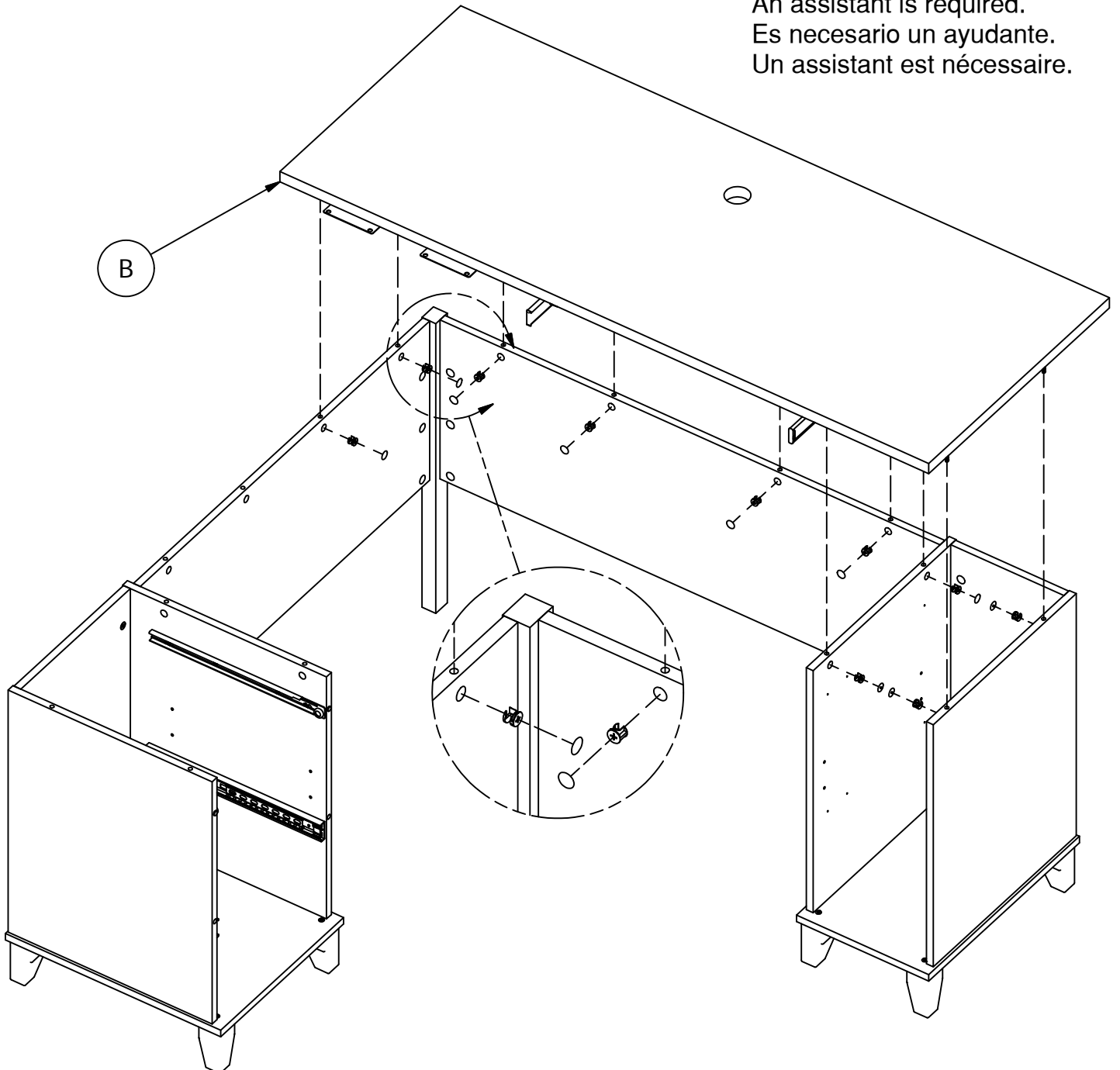

**STEP 41**

H72988

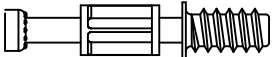

[ 6 ]

KD Bolt

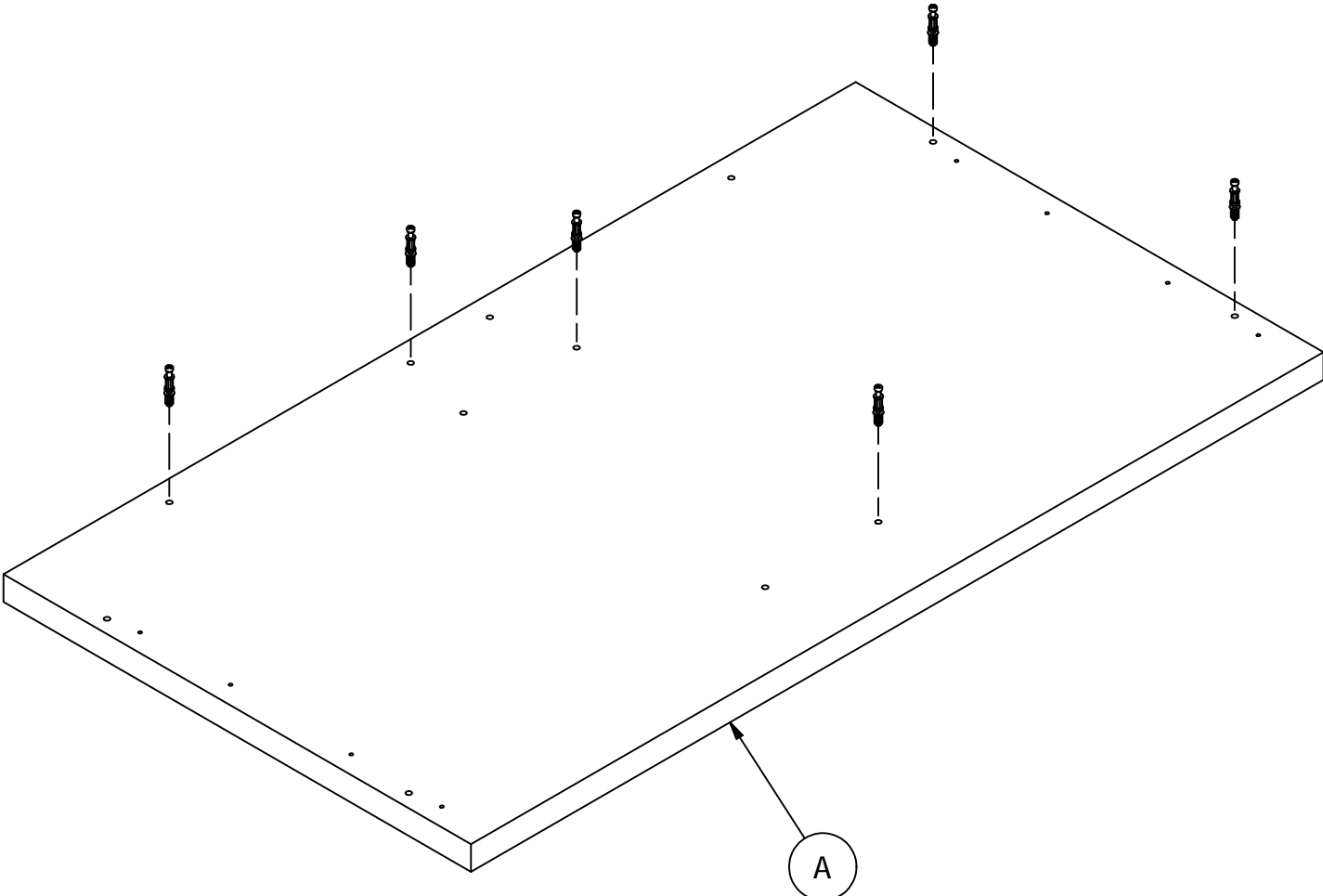
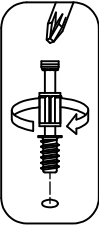

## STEP 42

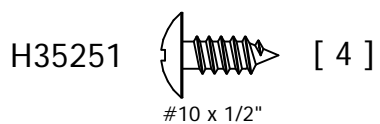
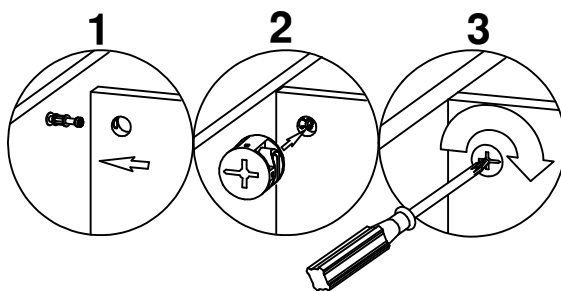
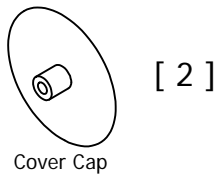
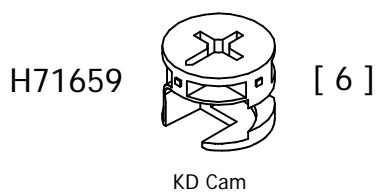

An assistant may be required.  
Un asistente puede ser necesario.  
L'aide d'une autre personne peut s'avérer nécessaire.

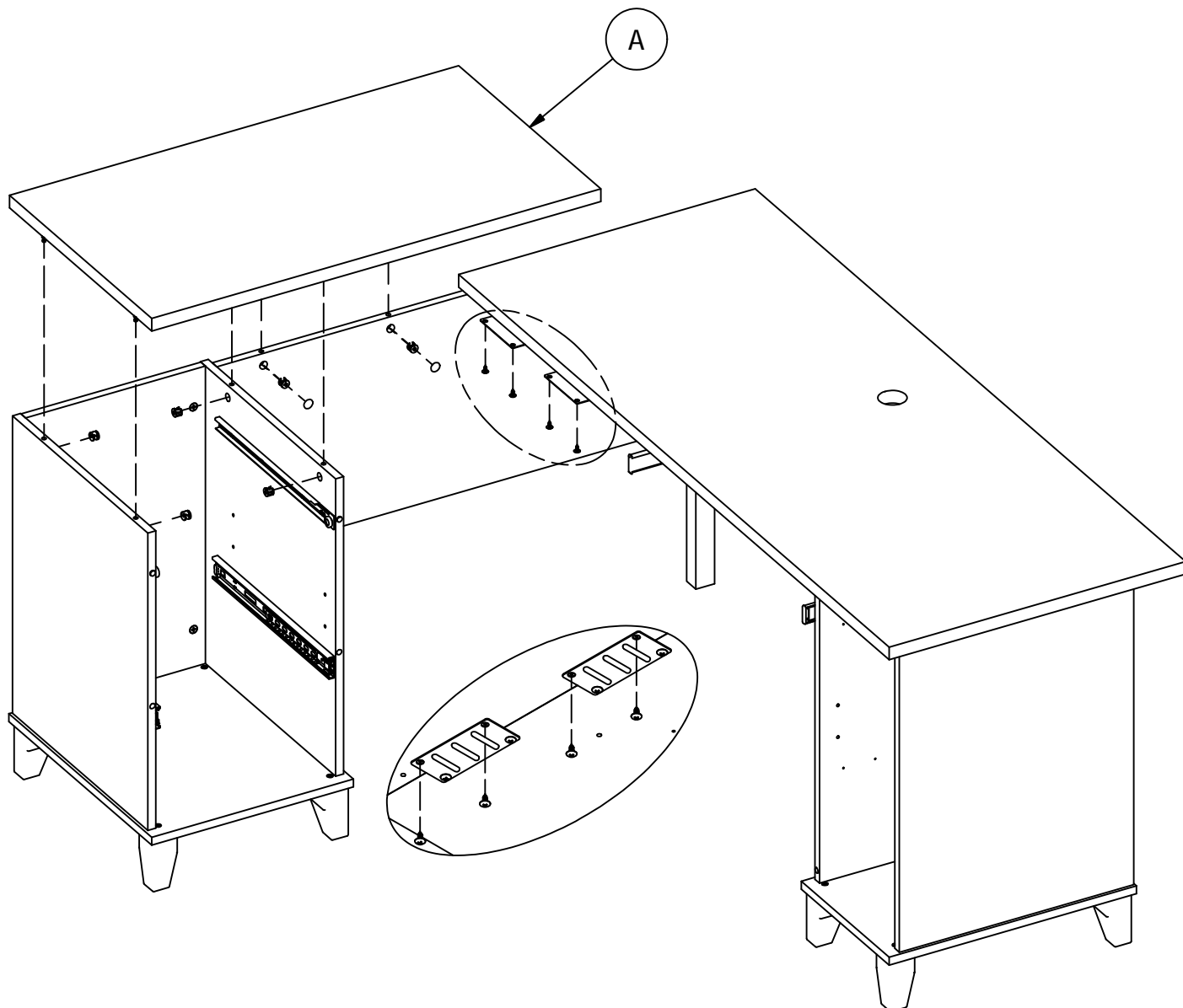

**STEP 43**

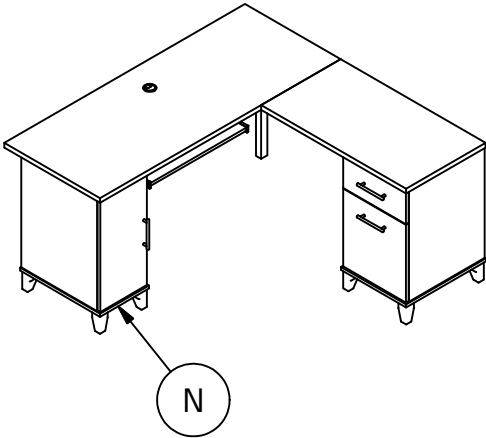

Or  
O  
Ou

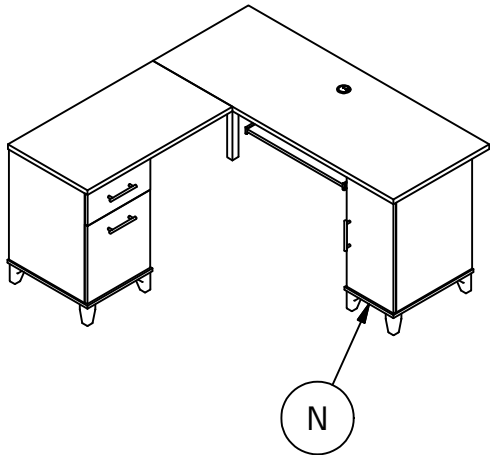

H23604

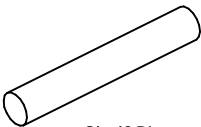

[ 4 ]

Shelf Pin

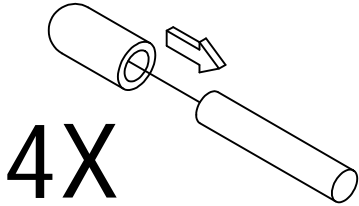

**4X**

H126396

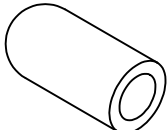

[ 4 ]

Shelf Pin Sleeve

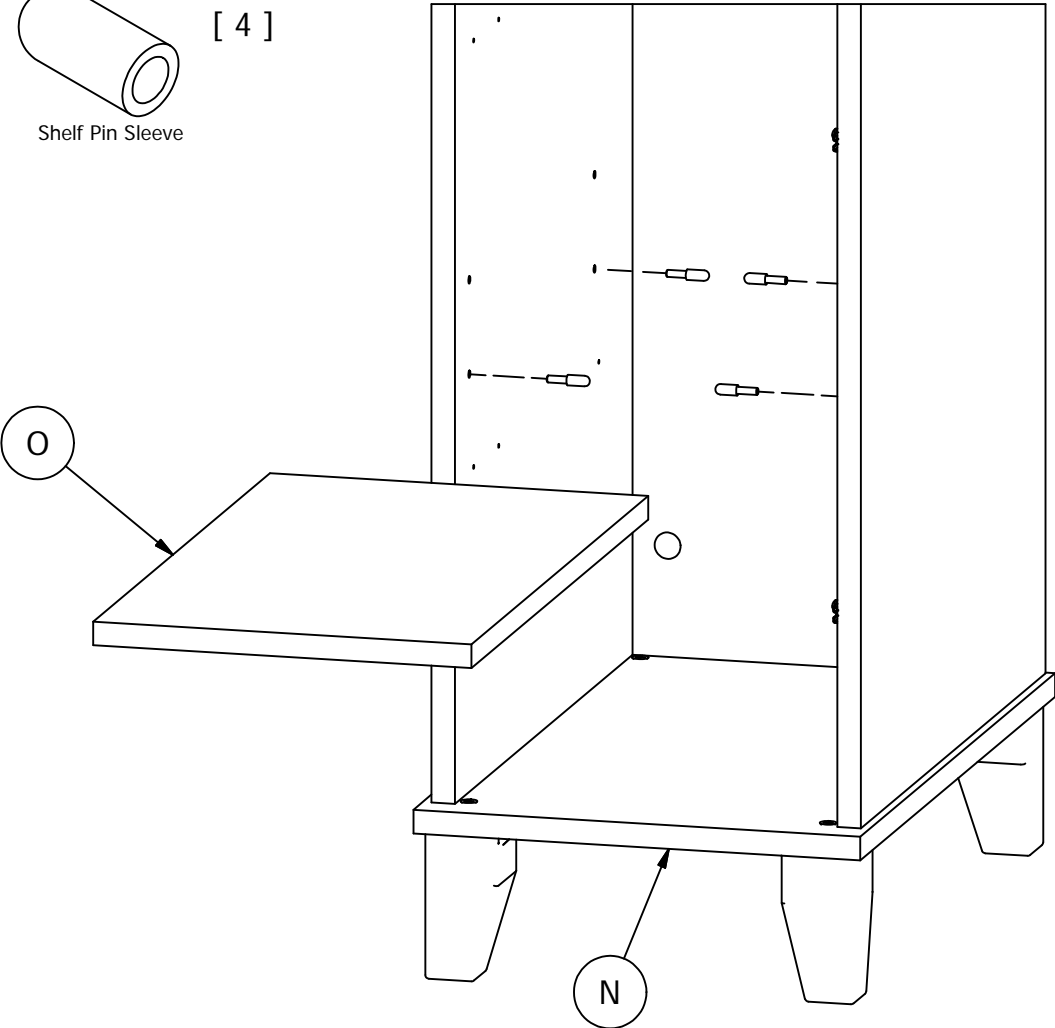

STEP 44

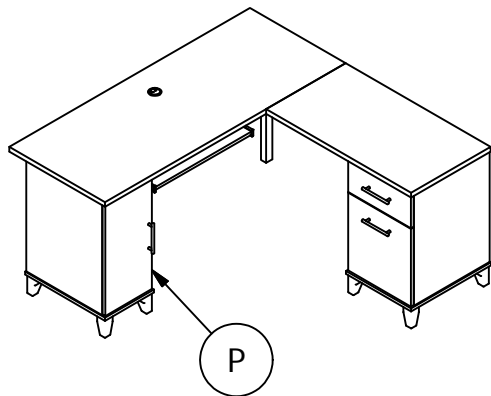

Or  
O  
Ou

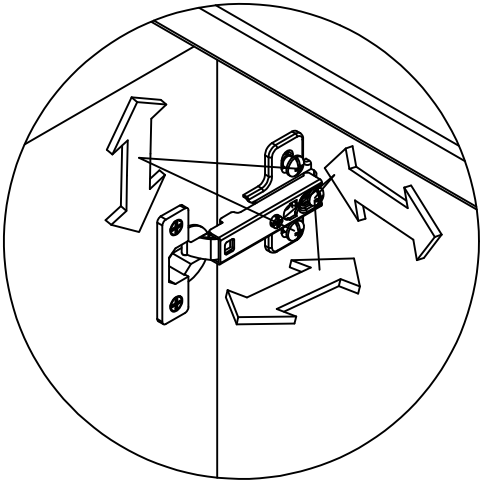
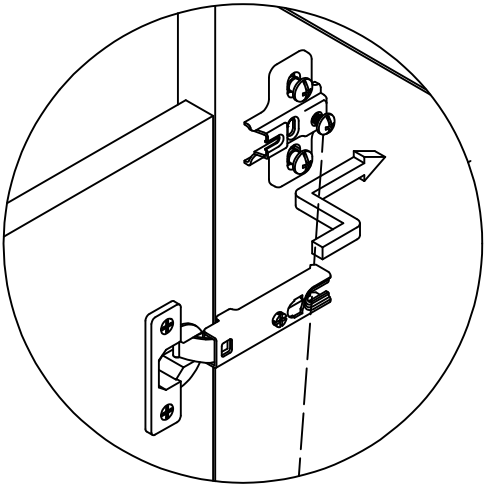
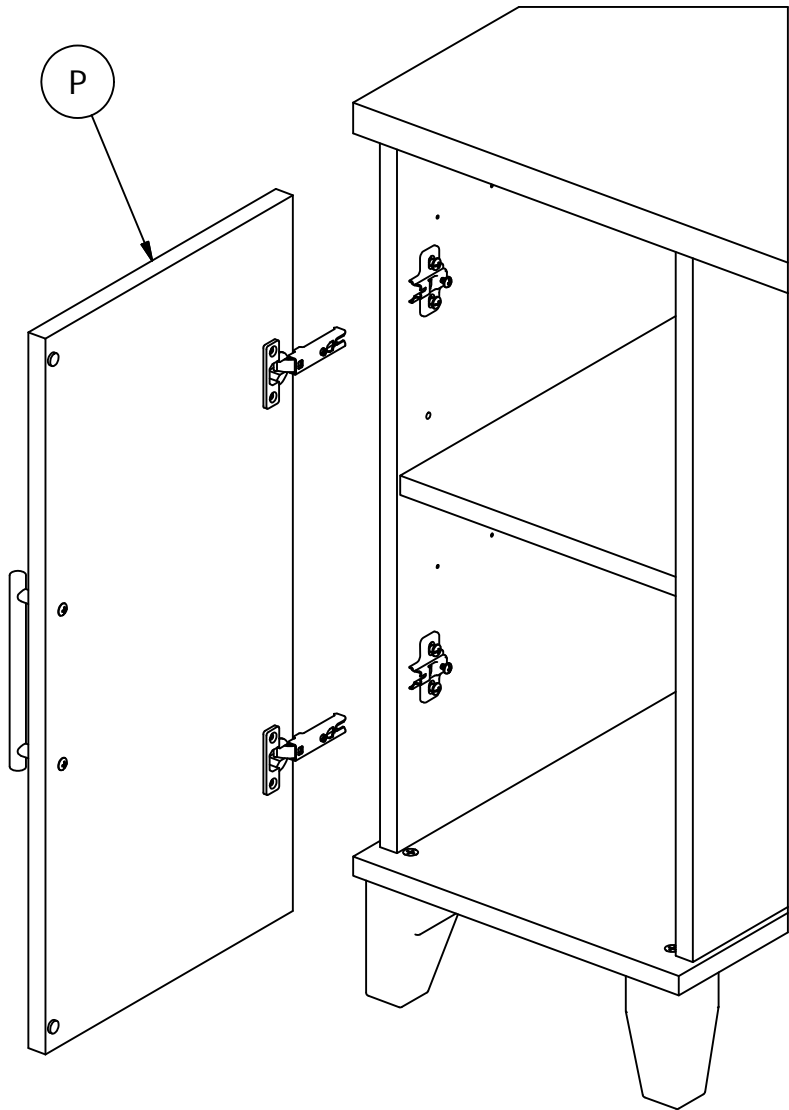
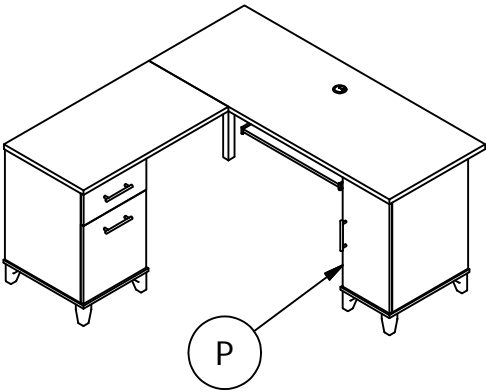

WATCH VIDEO

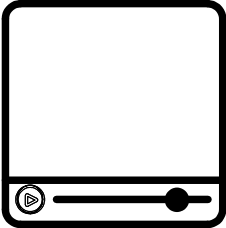

Install and adjust hinges

STEP 45

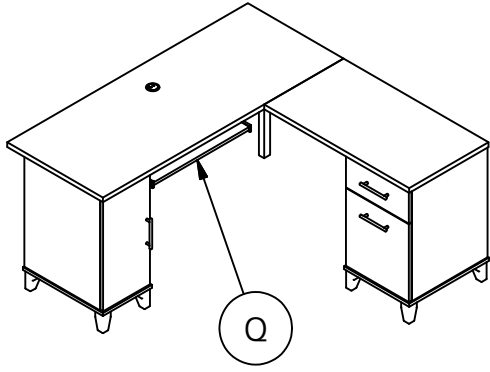

Or  
O  
Ou

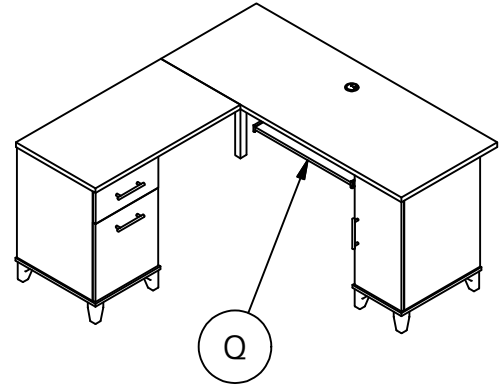

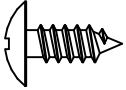
H35251  [ 4 ]  
#10 x 1/2"

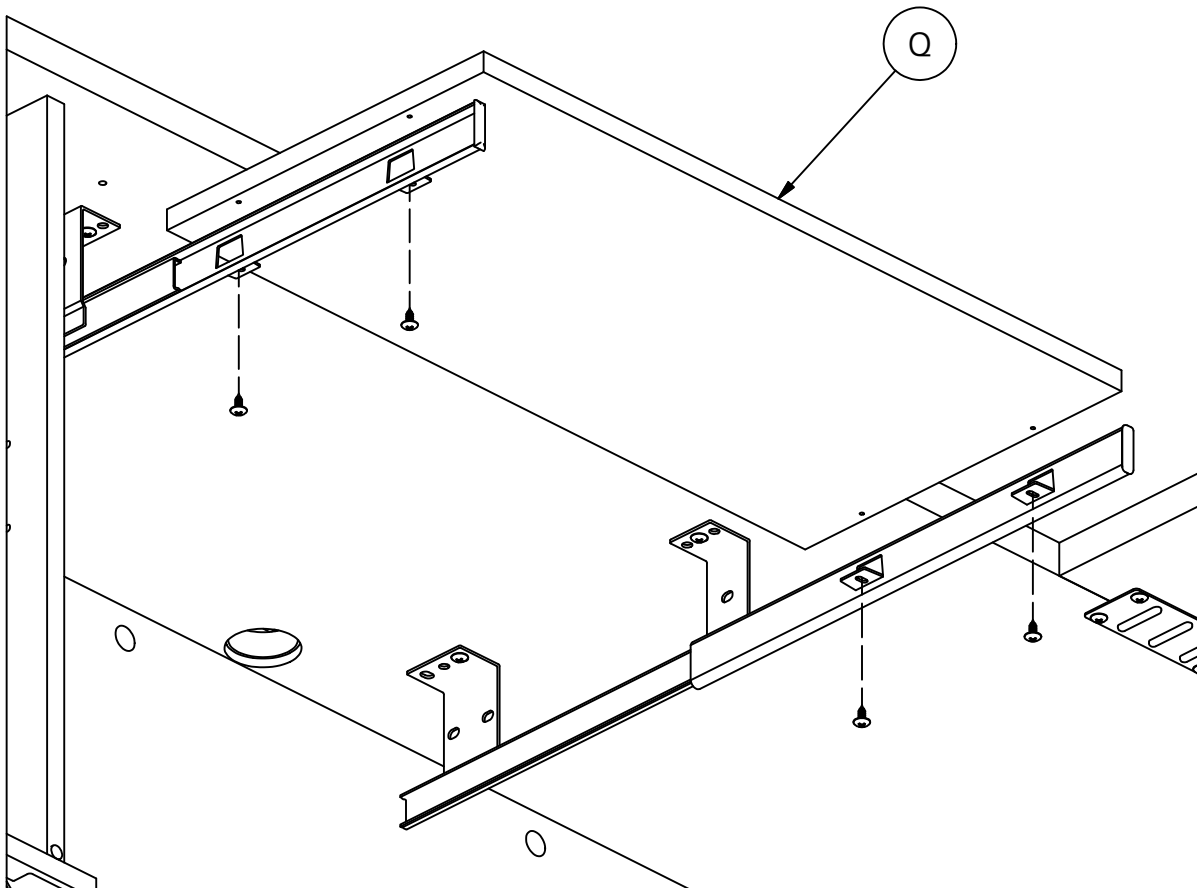

STEP 46

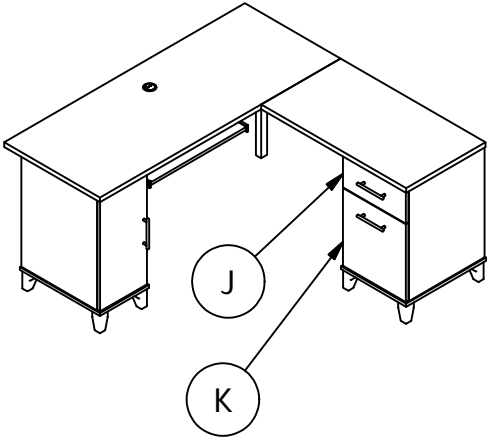

Or  
O  
Ou

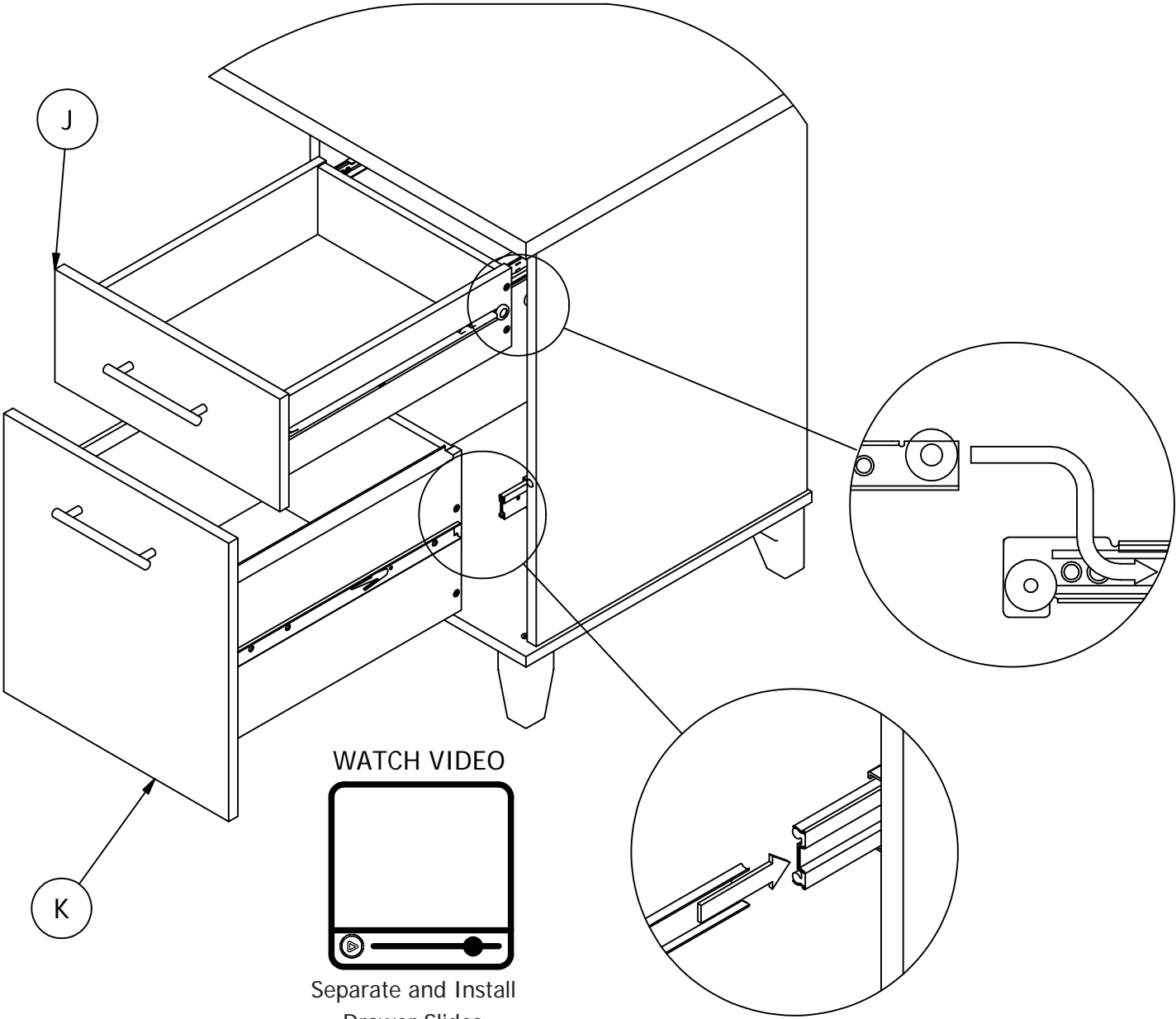
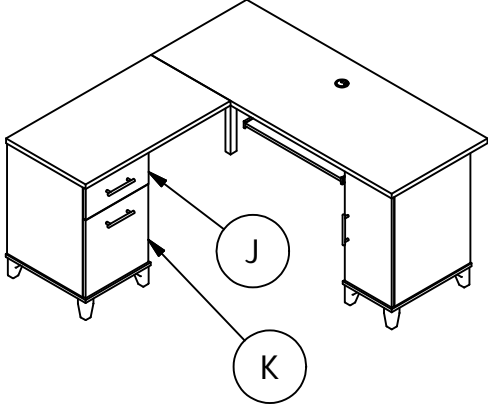

WATCH VIDEO

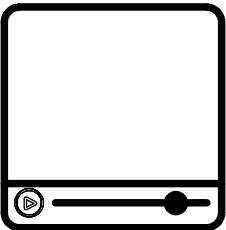

Separate and Install  
Drawer Slides

# STEP 47

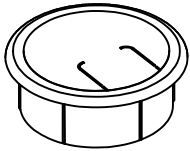

Grommet

[ 1 ]

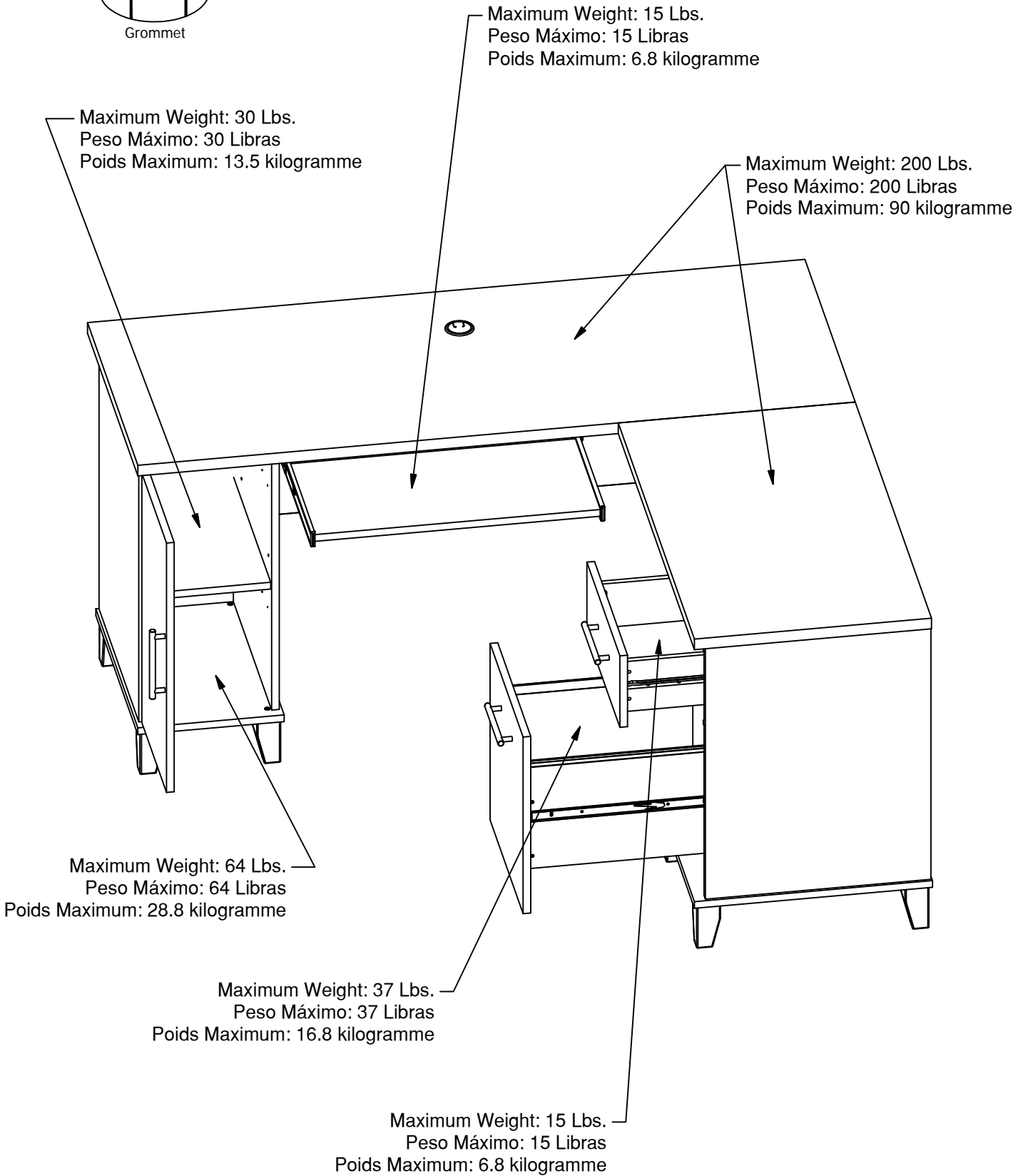

## STEP 48

- Move unit to final location.
- Coloque esta unidad en su posición permanente.
- Déplacez l'unité dans l'endroit final.
- Adjust drawer fronts as shown below.
- Ajuste la parte delantera de las gavetas según es indicado.
- Ajustez les façades de tiroir comme montré ci-dessous.

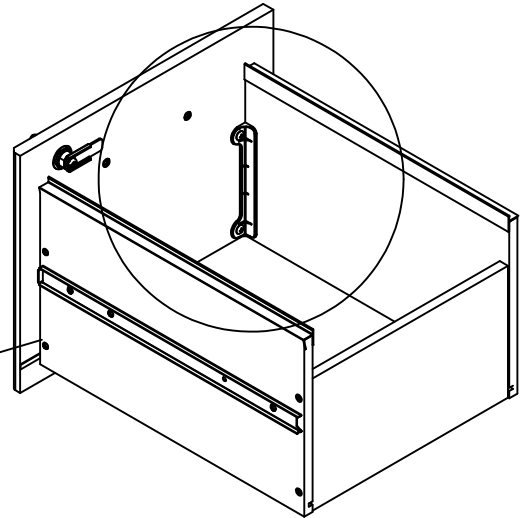
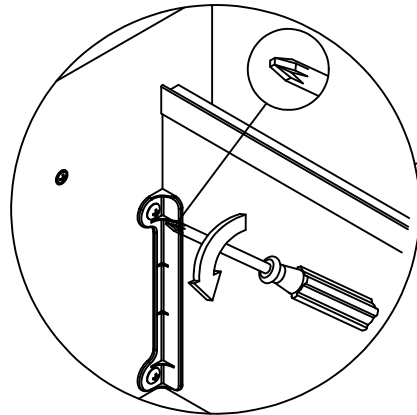

### STEP 1.

Loosen 4 screws on back of drawer front brackets as shown.

Afloje los 4 tornillos en la parte trasera de la gaveta según es indicado.

Desserrez les 4 vis dans les appuis en plastique sur le dos de l'avant de tiroir comme montré.

### STEP 2.

Position drawer front as required.

Ajuste la parte delantera de la gaveta según sea necesario.

Placez l'avant de tiroir comme nécessaire.

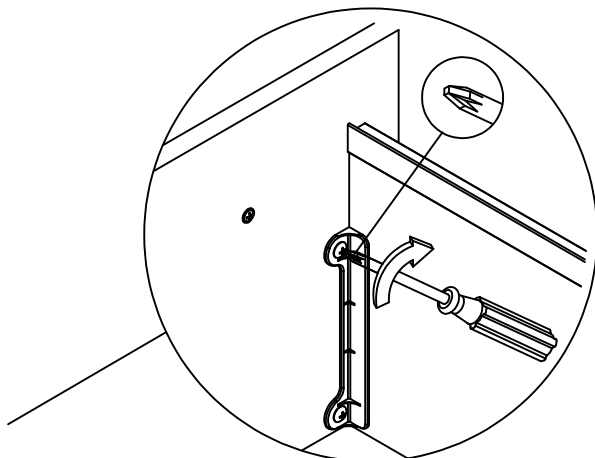
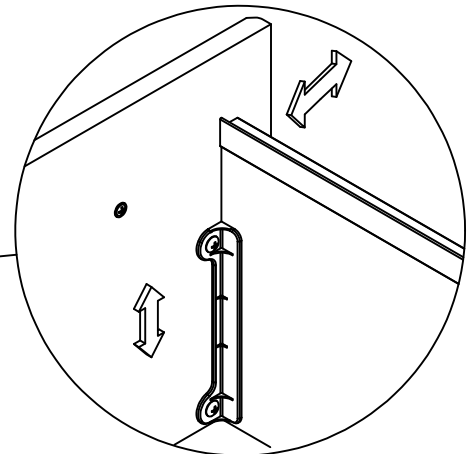

### STEP 3.

Tighten screws while holding drawer front in position.

Apriete los tornillos mientras sujeta la parte delantera de la gaveta en su posición permanente.

Serrez les vis tout en tenant l'avant de tiroir en position.

WATCH VIDEO

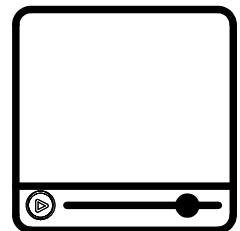

Adjust drawer fronts