

# ELECTRIC HEIGHT ADJUSTABLE DESK

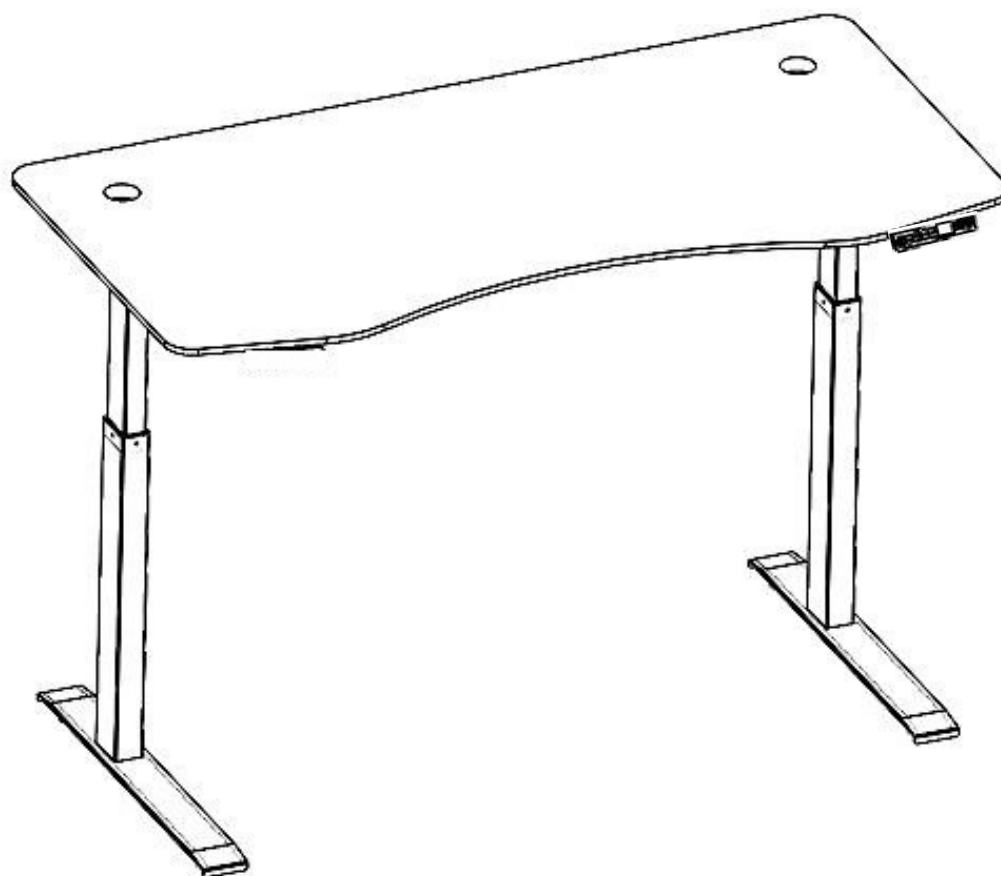

*Assembly  
Instructions*



# TABLE OF CONTENTS

Safety Instructions .....	03
Unpacking & Components.....	04
Desk Diagram .....	05
Installing Columns.....	06
Installing Feet & Controller.....	08
Connecting Cables .....	09
Initializing System .....	10
Troubleshooting.....	11
Warranty .....	14

# SAFETY INSTRUCTIONS

## WARNING!

FAILURE TO COMPLY WITH OR OBSERVE ALL ASSEMBLY, SAFETY AND OPERATING INSTRUCTIONS AND WARNINGS REGARDING THE USE OF THIS PRODUCT MAY RESULT IN SERIOUS BODILY INJURY.

### TO ASSURE SAFER OPERATION:



Read and understand this manual before attempting to install or operate.



Assure that everyone who uses this product is informed of the contents of this manual. This is the responsibility of the Purchaser.



This product is not intended for use by young children or for those persons who require supervision.

Safe use of this product is possible only when the operating instructions are read completely and the instructions contained are strictly observed. Persons who do not have the necessary experience or knowledge of this product must not use the product. Persons with reduced physical or mental abilities should not use this product, unless they are under supervision or they have been thoroughly instructed in the use of the apparatus by a person who is responsible for the safety of these persons. Children should be closely supervised to ensure that they do not play with this product.



This product must be INITIALIZED before use. Read the initialization part of the manual first prior to operating.

#### BEFORE INSTALLATION, REINSTALLATION, OR TROUBLESHOOTING:

- Switch power off and disconnect power cord from the power outlet.
- Remove any loads or items from the work surface because movement may occur unexpectedly.

#### BEFORE START-UP:

- Make sure desk has been initialized.
- Check all connections and cables. Make sure control box is connected to a power outlet.
- If the control box makes unusual noises or emits an odor, switch power off immediately.

# UNPACKING & COMPONENTS

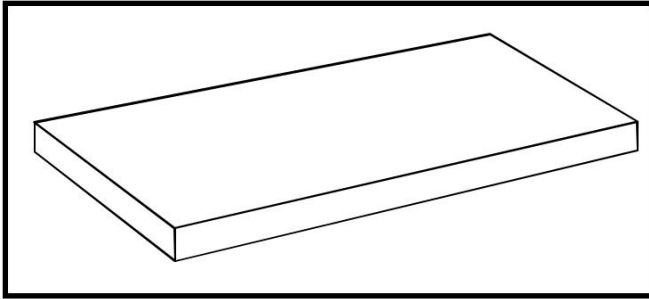

TABLE & COMPONENTS BOX

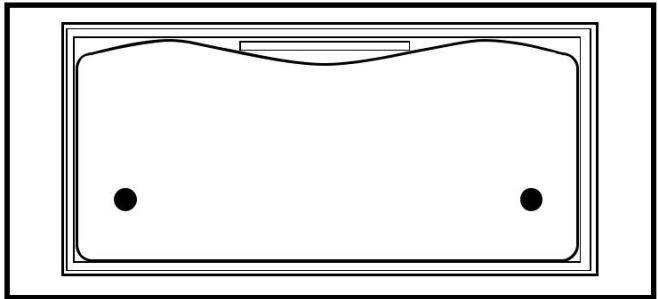
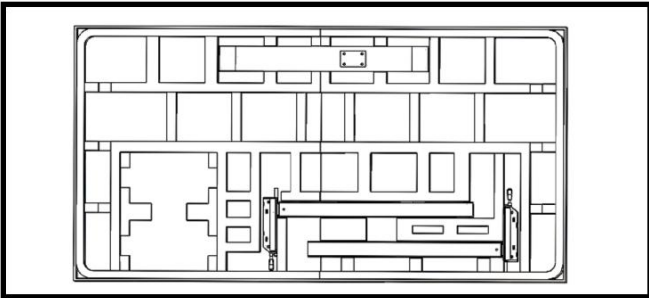
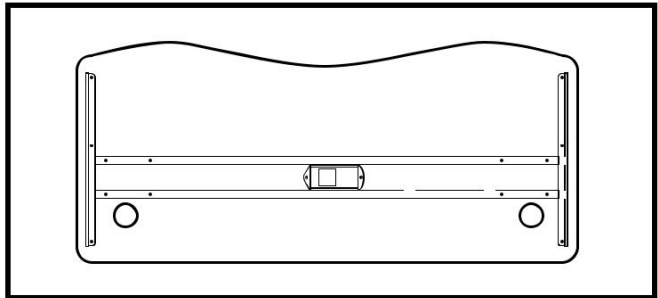

TABLE TOP VIEW









COMPONENTS

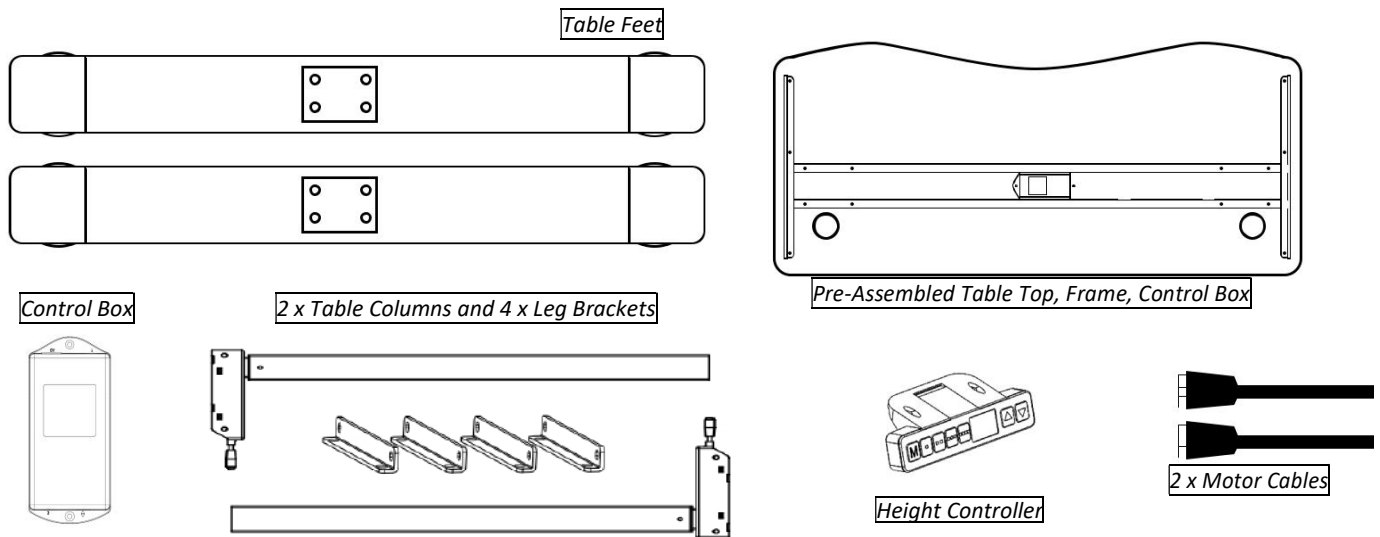

PRE-ASSEMBLED TABLE BOTTOM VIEW

The desk comes in one box. Carefully remove the contents from the package and inspect all components for damage. Don't install if there is visible physical damage on any component. The table top and frame *with the control box* are *PRE-ASSEMBLED* making it quick and easy to assemble.



HARDWARE CONTENTS					
Ref.	Qty.	Description	Ref.	Qty.	Description
A	16	M6x16 Hexagon Screw 	D	8	M5*12 Hexagon head screws 
B	2	ST4.8x13 Pan Head Screw 	E	1	3mm Wrench 
C	1	4mm Allen Wrench 			



Power Cable

# DESK DIAGRAM

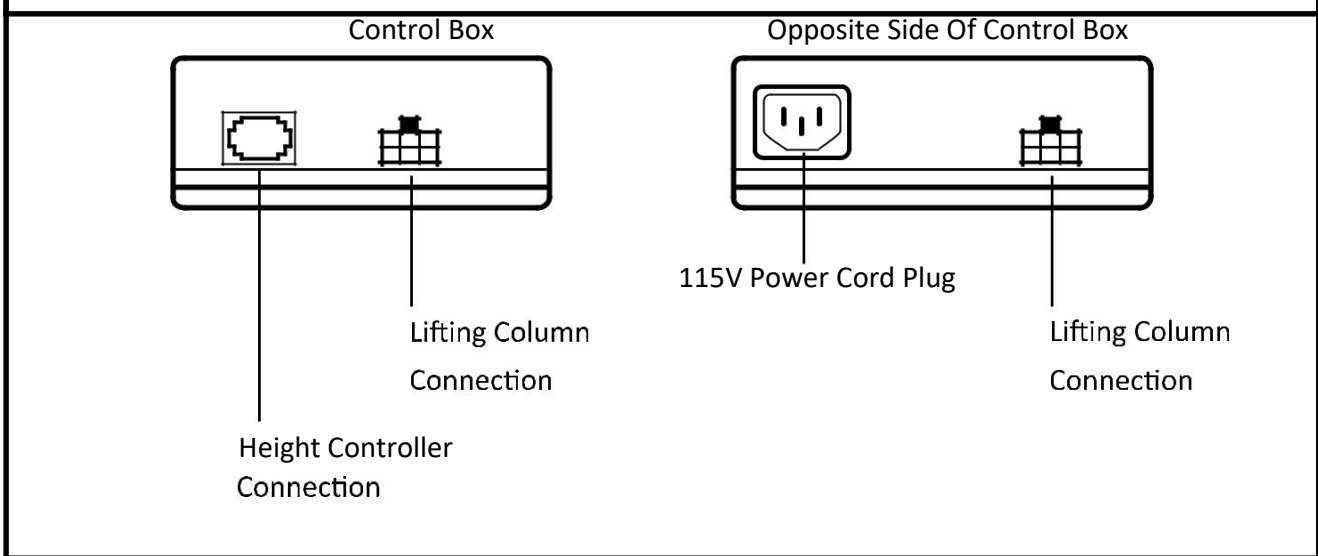
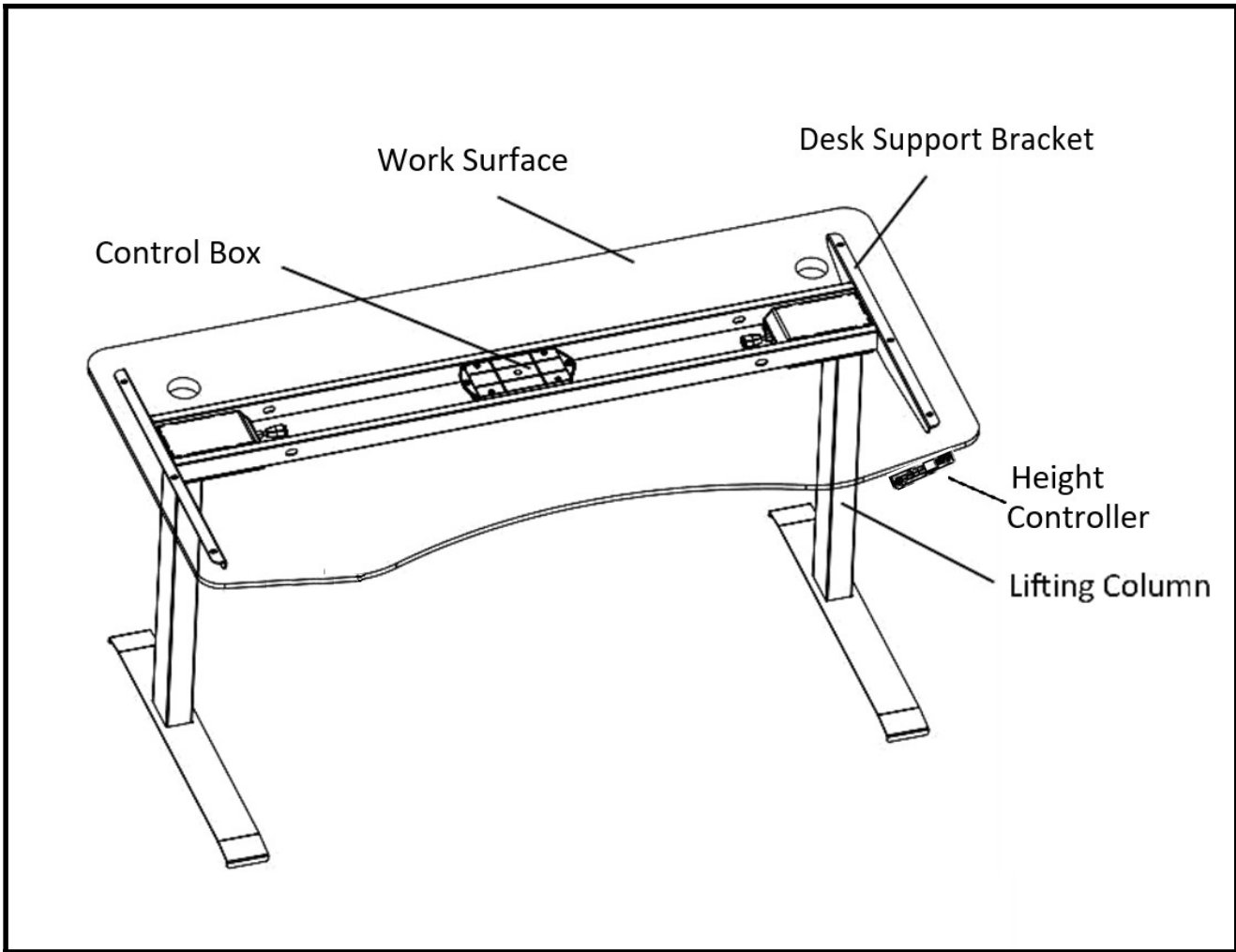

## INSTALLING COLUMNS

Before attaching the column to the frame, use a 3mm wrench and M5\*12 Hexagon head screw to secure the leg brackets to the column. As shown below, each column requires leg bracket.

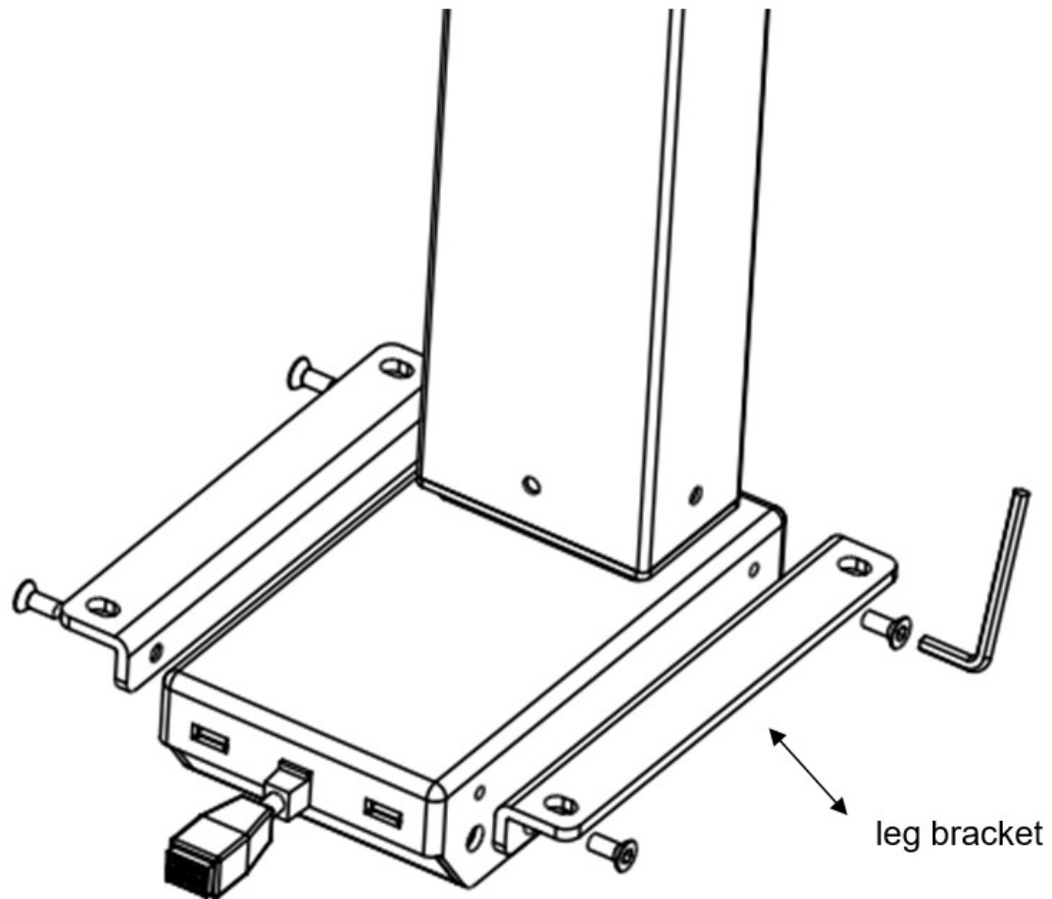

# INSTALLING COLUMNS

Place desk top on a flat and non-abrasive surface. Carefully place under frame onto the desktop. The under frame is heavy two people will be needed to move the under frame and turn over the desk after it is done.

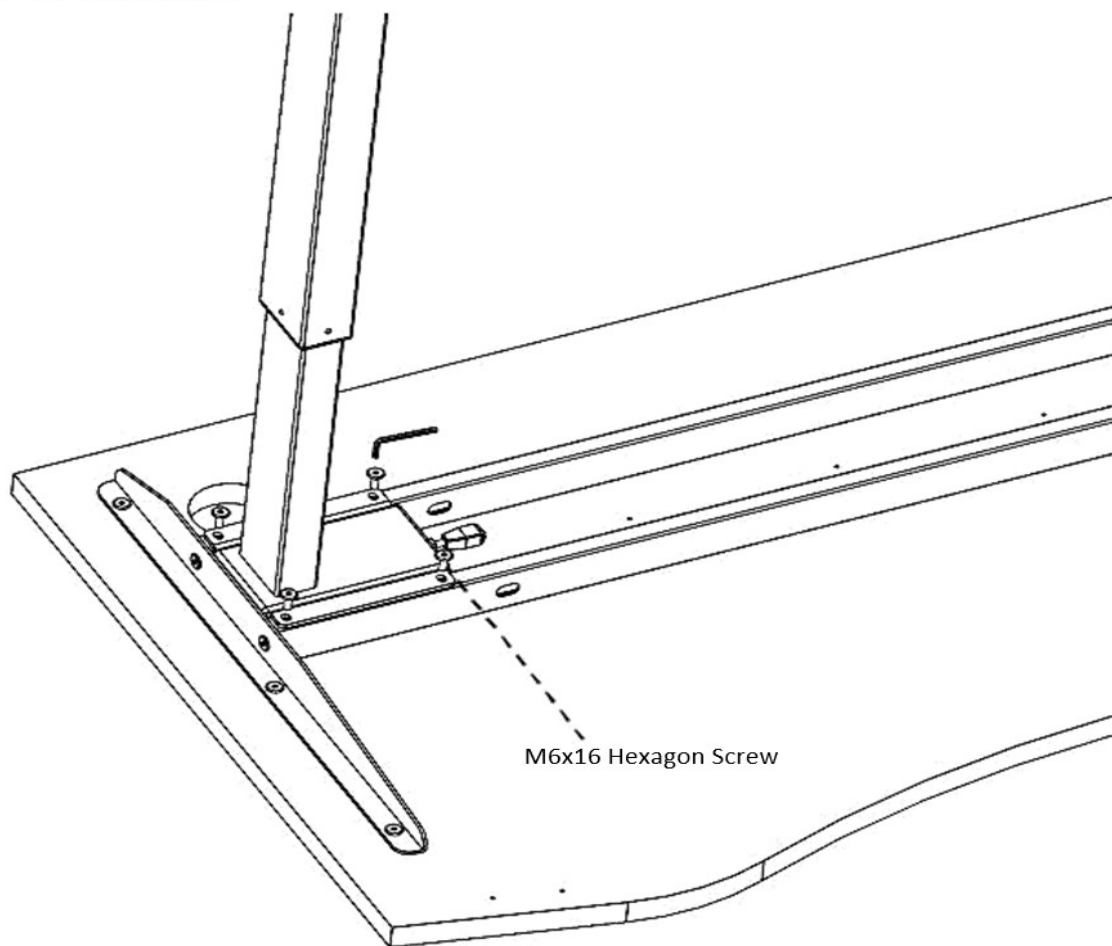

Make sure column is set properly onto the frame as shown below and use the M6x16 Hexagon Screws to secure the column onto the pre-installed frame.

Use (A) M6x16 Hexagon Screw



# INSTALLING FEET & CONTROLLER

Use 4mm Allen wrench (C) to secure each foot with four M6x16 Hexagon Screws (A).  
(see page 4 for reference)

- A) M6x16 Hexagon Screw 
- C) 4mm Allen Wrench 

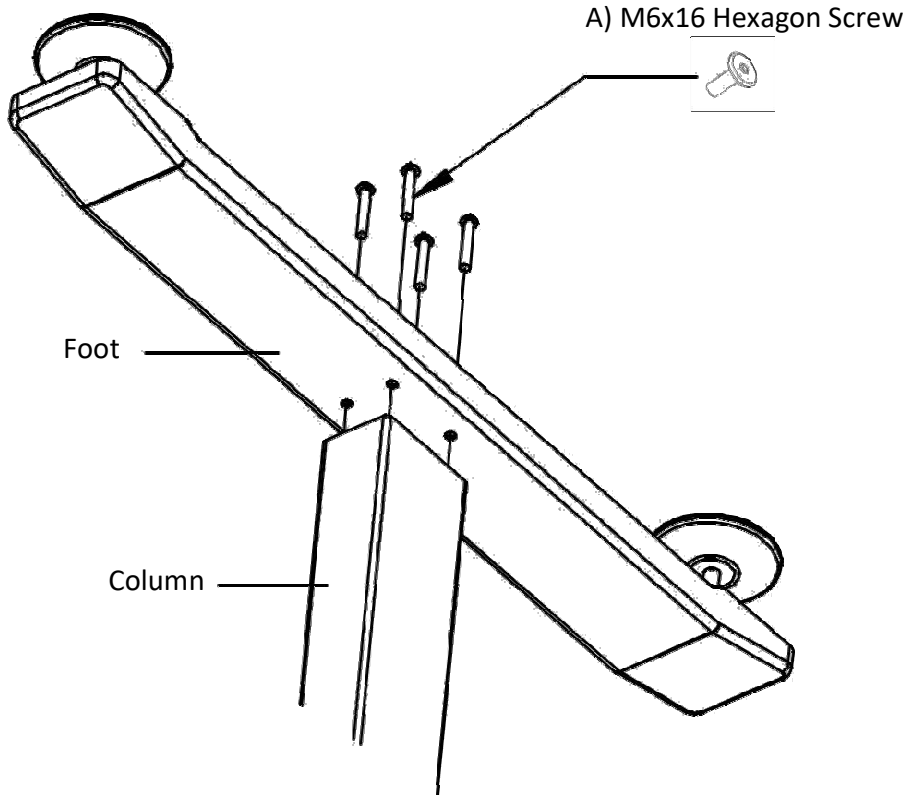

Use screw ST4.8x13 Pan Head Screws (B)  
to secure the Height Controller to the desk top.

*Note: Holes are pre-drilled.*

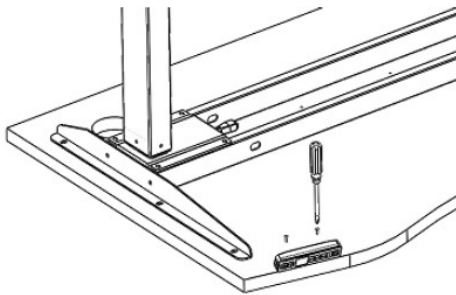

secure the Height Controller to the right side of desk top

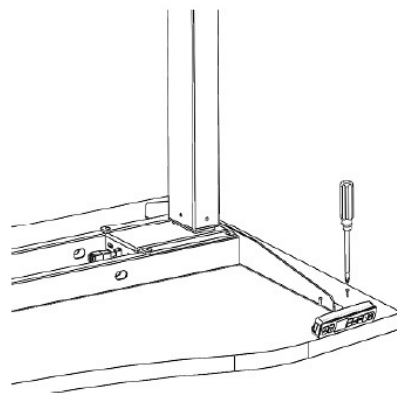

Or secure the Height Controller to the left side of desk top

# CONNECTING CABLES

- 1) Connect Height Controller cable connector to Control Box.
- 2) Connect Lifting Column cable to the Control Box.
- 3) Plug power cord to Control box.
- 4) Plug power cord to power outlet.

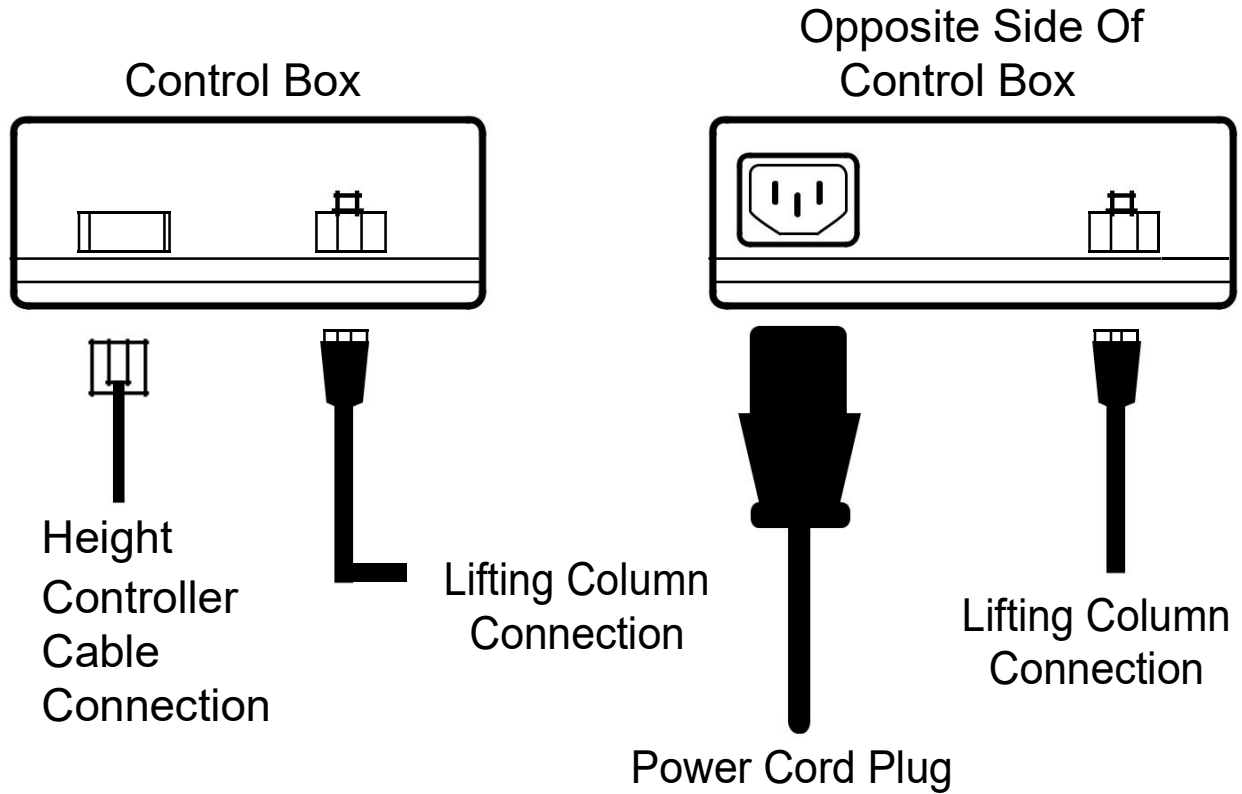

## INITIALIZING SYSTEM & SETING HEIGHT POSITIONS

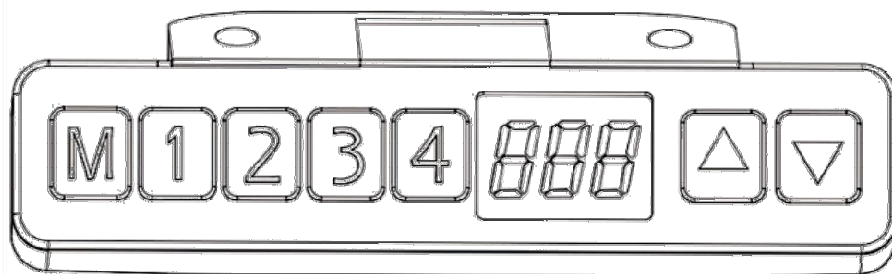

**Use the Height Controller to initialize. The desk needs to be initialized before your first use.**

Press and hold the UP and DOWN arrows simultaneously for 6 seconds to start the initialization process. The LED display will show 3 blinking zeros. The desk will start moving -- first to the lowest position, then the highest position and finally stops in between. The initialization is completed when number 38 (+/-0.2) appears on the display. Your desk is now ready to use.

\*\*\*Highest position will be at 48" and lowest is 28"\*\*\*

### **Preset Table Heights**

You can preset up to four positions. Use UP and DOWN arrow buttons to move desk to your desired position. Press M plus one of the number buttons together for 1 to 3 seconds until displayed height starts blinking, and then release the buttons. To go to your preset height, simply press the number button TWICE or press and hold the button.

\*\*\*One USB Charging Port included\*\*\*

USB Charging: 5V DC 2.4 Amp for cell phone and tablet charging only

### **SAFETY FEATURE**

Hold "M" and "UP" buttons for 4 seconds to lock all buttons, the following code will be displayed on the control panel screen. 

Hold "M" and "DOWN" buttons for 5 seconds to unlock all buttons.



If the system STOPS working and shows "HOT" on the screen. This means the control box is under overheat protection mode. Wait a few minutes and let it cool down to 25°C this will solve the problem.

# TROUBLESHOOTING

1. Issue: The desk does not go up or down

Solution: Check all connections. Make sure there is power to the desk.  
Then try to re-initialize the desk.

2. Issue: Columns do not go up or down evenly

Solution: Re-initialize the desk.

3. Issue: Table will not go up just down

Solution: Reduce the weight on the table

4. Issue: The desk wobbles excessively

Solution: It is normal for the desk to wobble slightly at standing height.  
Adjust leveling feet. Make sure all screws are tightened.

5. Issue: The system not working and showing HOT on the screen.

Solution: This is because the control box under overheat protection mode it shuts off to protect itself. Once the temperature goes back to 25°C it will be ok to re-initialize.

## SYSTEM FAILURE CODES

Codes	Description	Solution
---	Initialization failed	Press and hold the UP and DOWN arrows simultaneously for 6 seconds, then release two bottoms to start the initialization process. The desk will start moving-- rest to the lowest position, then the highest position and finally stops in the mid position. The desk is now ready to use.
E-0	Control box malfunction	Please contact service center
E-1	System malfunction	Please contact service center
E-3	Starting current exception	Please re-initialize the system; if failure code still show on the screen, please contact the service center
E-4	Main power supply malfunction	Please contact service center
E-5	Motor A Hall element malfunction	Please check all connection and re-initialize the system; if failure code still shows on the screen, please contact the service center
E-6	Motor A stalling	Please re-initialize the system; if failure code still show on the screen, please contact the service center
E-7	Motor B stalling	Please re-initialize the system; if failure code still show on the screen, please contact the service center
E-8	Motor wiring malfunction	Please check all connection and re-initialize the system; if failure code still shows on the screen, please contact the service center
E-9	Motor B Hall element malfunction	Please check all connection and re-initialize the system; if failure code still shows on the screen, please contact the service center
E-11	Anti-Collision protection starts	Please re-initialize the system; if failure code still show on the screen, please contact the service center
E-12	System running over 2 mins	Please let it sit for 18 mins, duty cycle is 10%
E-14	Main power over 45V	Please contact service center
E-15	Over 1 cm deviation between 2 legs	Please re-initialize the system; if failure code still show on the screen, please contact the service center

## SYSTEM FAILURE CODES

Codes	Description	Solution
E-16	Handset connection failure	Please check handset connection to the control box
E-17	Handset communication failure	Please check handset connection to the control box; if failure code still shows on the screen, please contact the service center
E-18	Power lower than 24V	Please contact the service center
E-19	Desktop Tilt	Please re-initialize the system; if failure code still shows on the screen, please contact the service center
E-42	Data memory error	Please contact the service center
E-43	Anti-Collision sensor malfunction	Please re-initialize the system; if failure code still shows on the screen, please contact the service center

# WARRANTY

## WARRANTY

Manufacturer covers table top and mechanical components for 5 years and covers electrical components for 2 years.

Manufacturer warranty is only valid in so far as the equipment has been used and maintained correctly and has not been tampered with. Furthermore, the system must not be exposed to violent treatment. In the event of this, the warranty will be ineffective/invalid.