

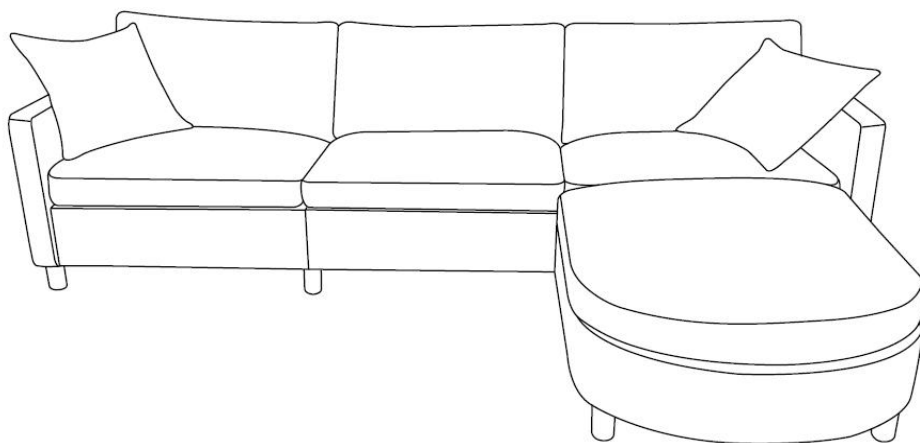



Assembly Instructions







Caution : You must read this before you proceed

Sofa

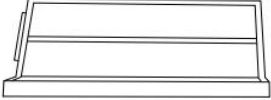
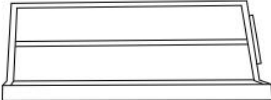
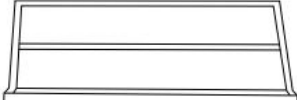





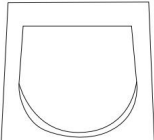

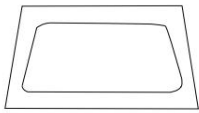
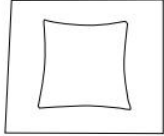
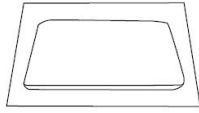

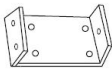

Parts List

Label	Picture	Description	QTY
A		Left Armrest	1
B		Right Armrest	1
C		Left Front Rail	1
D		Right Front Rail	1

E		Middle Front Rail	1
F		Left Back Frame	1
G		Right Back Frame	1
H		Middle Back Frame	1
I		Connecting Pipe	2
J		Ottoman Frame	1
K		Back Fabric Cover	1
L		Left Seat	1
M		Right Seat	1
N		Middle Seat	1
O		Compressed Ottoman Seat Cushion	1

P		Compressed Back Cushion	3
Q		Compressed Arm Pillow	2
R		Compressed Seat Cushion	3





Hardware

Label	Picture	Description	QTY
①		Leg	10
②		Middle Leg	2
③		Plastic Washer	16
④		Front Leg Installation Piece	2
⑤		Back Leg Installation Piece	2
⑥		Tapered Connector	2
⑦		Bolt (M8*70MM)	5
⑧		Bolt (M8*25MM)	23
⑨		Bolt (M6*25MM)	5
⑩		Flat Washer	28
⑪		Allen Wrench(S5)	1
⑫		Allen Wrench(S4)	1

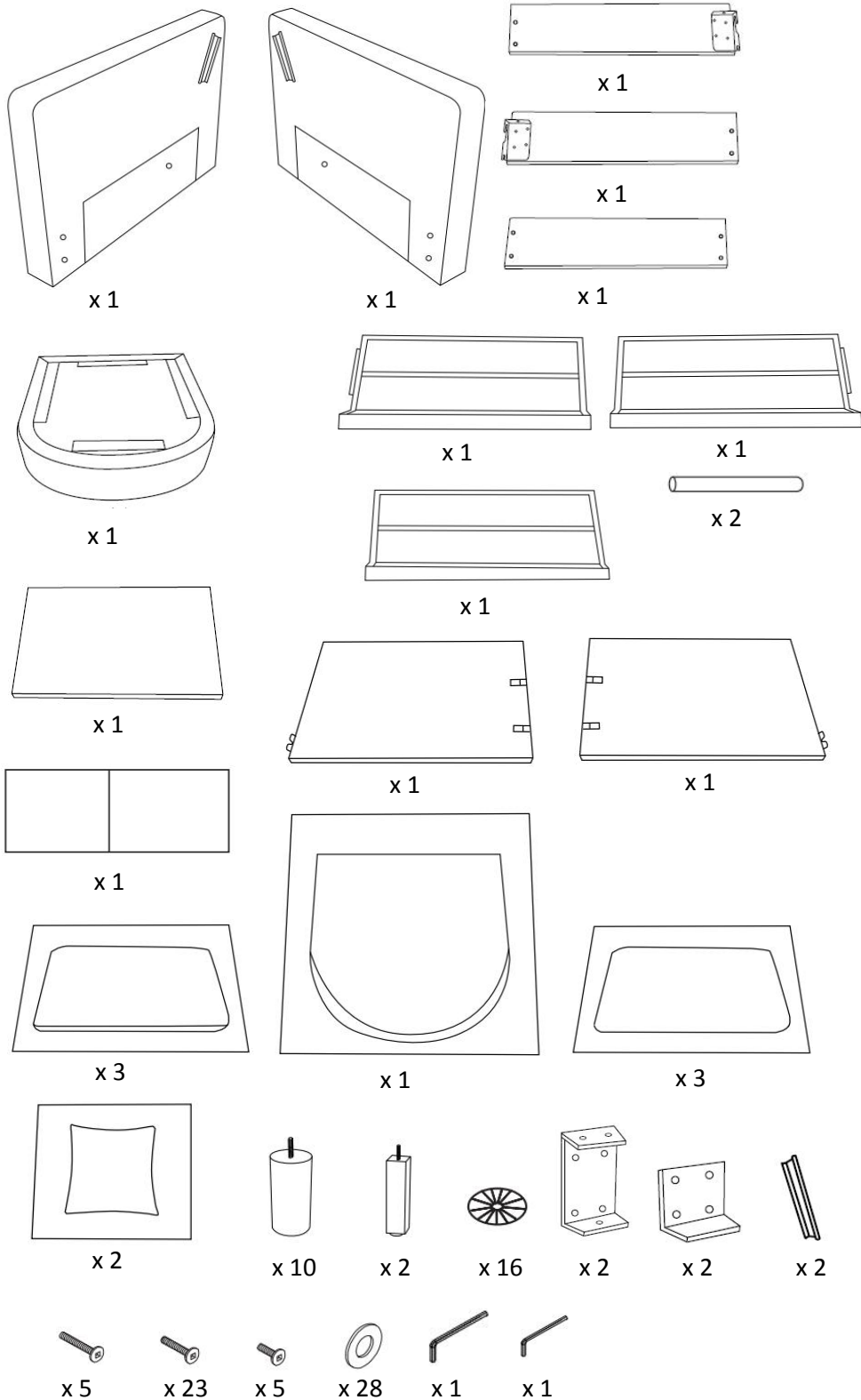
Assembly Preparation

Before Beginning Assembly :



-  • Read instructions, cover to cover-
-  • Have 2 adults on hand for assembly-
-  • Do not assemble on flooring or carpet-
-  • Assemble on a clean non-marring surface (packing foam)-
-  • Save all packaging until finished-

Assembly Steps

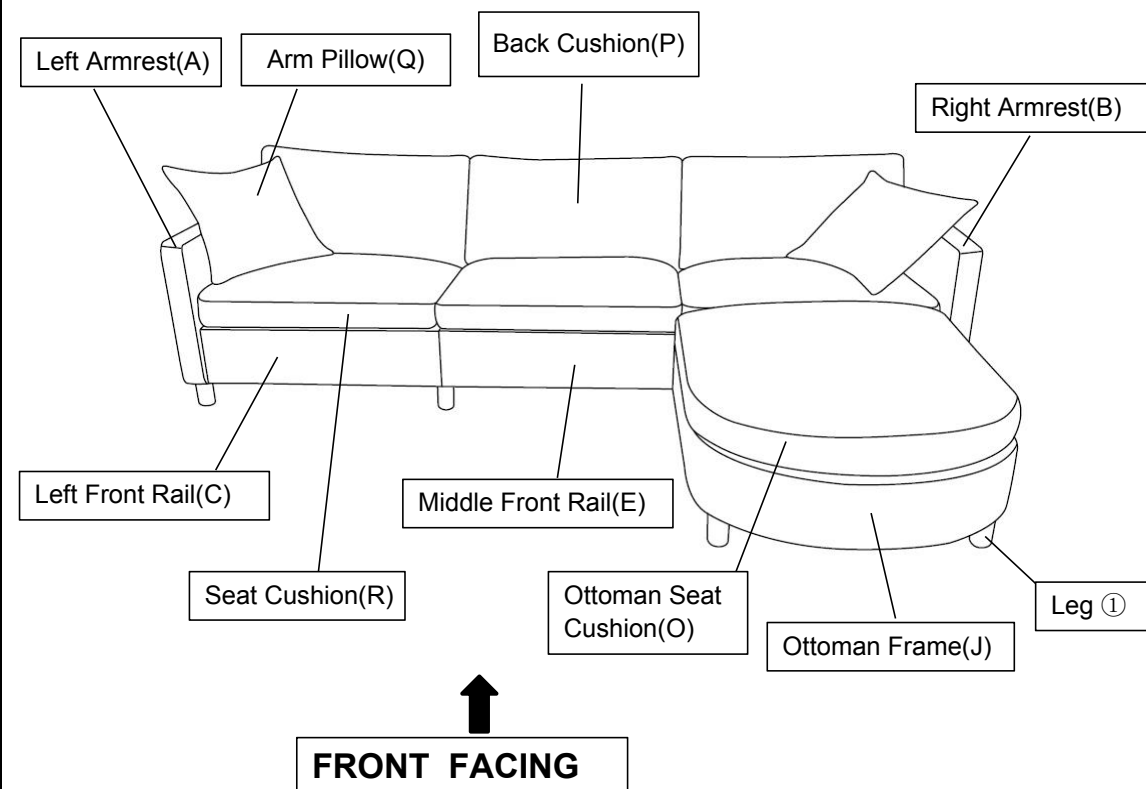

This Sofa has multiple parts and may require up to 45 minutes to assemble. To give you an overview of the Sofa parts, the above picture is to help you put the various parts into perspective. Please read through the instructions below to familiarise yourself with the parts and steps before assembly.

Note: It is recommended that you have an adult partner to assist during the entire assembly process.

Step 1

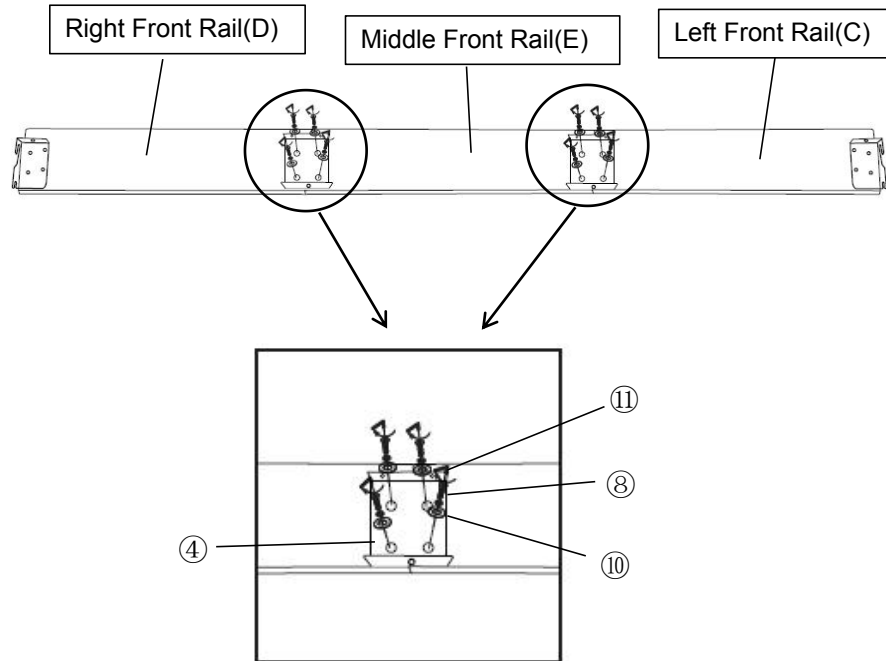

Open the carton and place all the parts on a clean, non-marring surface. Put Right Front Rail(D), Middle Front Rail(E) and Left Front Rail(C) together in a line, then install the Front Leg Installation Piece (4) by using Bolt(8), Flat Washer (10) with Allen Wrench(11) as shown above, turning clockwise until tight.

Step 2

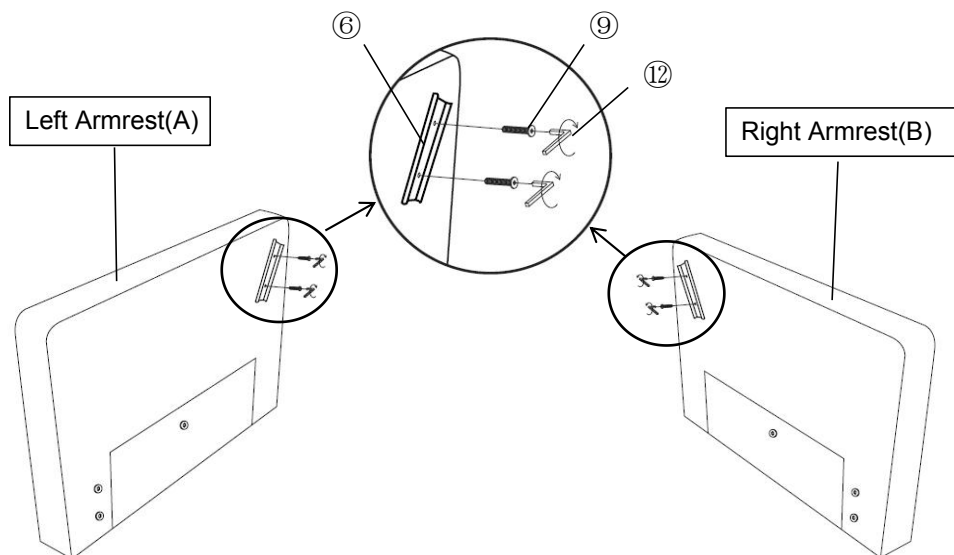

Install the Tapered Connector(6) to Left Armrest(A) by using Bolt(9), with Allen Wrench(12) as shown above, turning clockwise until tight. Repeat the same step with Right Armrest(B).

Step 3

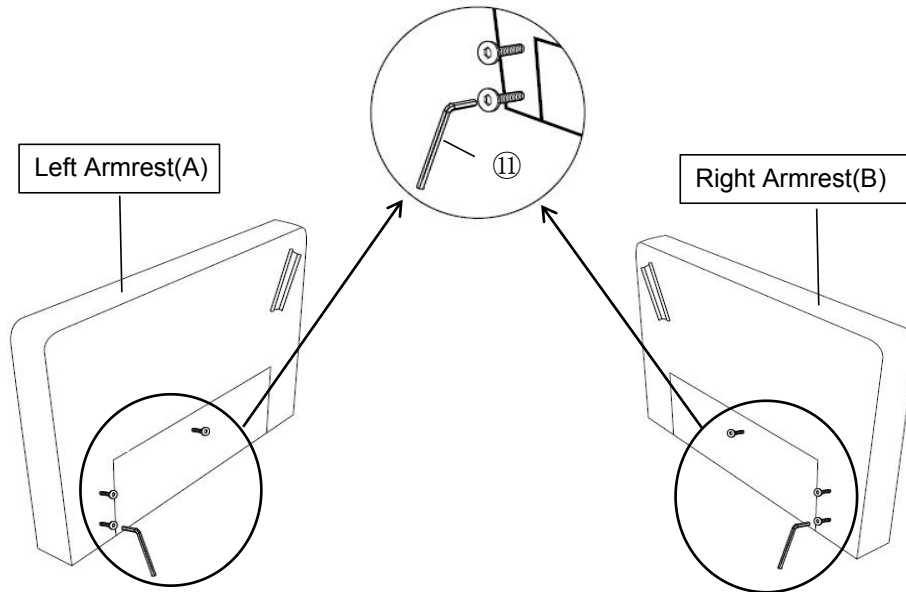

Loosen the Bolts on Left Armrest(A) and Right Armrest(B) with Allen Wrench(11) about one inch.

Step 4

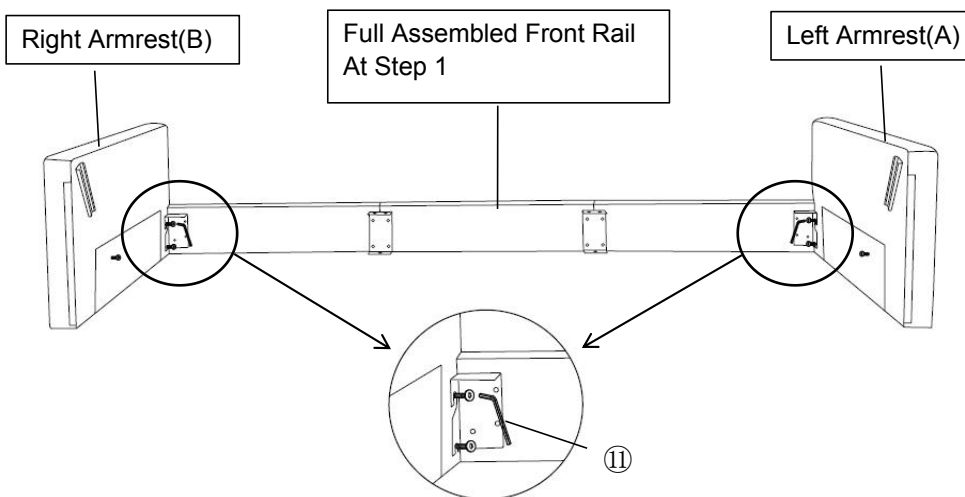

With the assistance of your partner, slide the hook in the end of Front Rail into the bolts on the Left Armrest(A) and Right Armrest(B), then tighten the bolts as shown in Picture.

Step 5

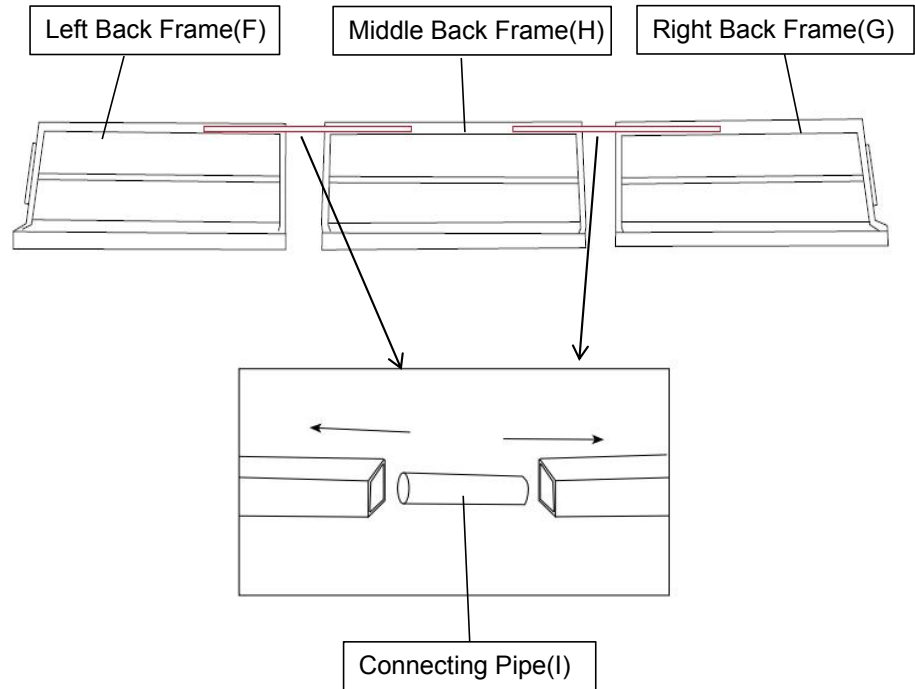

Connect the Left Back Frame (F), Middle Back Frame (H), and Right Back Frame (G) with the Connecting Pipe (I), as shown in the picture above.

Step 6

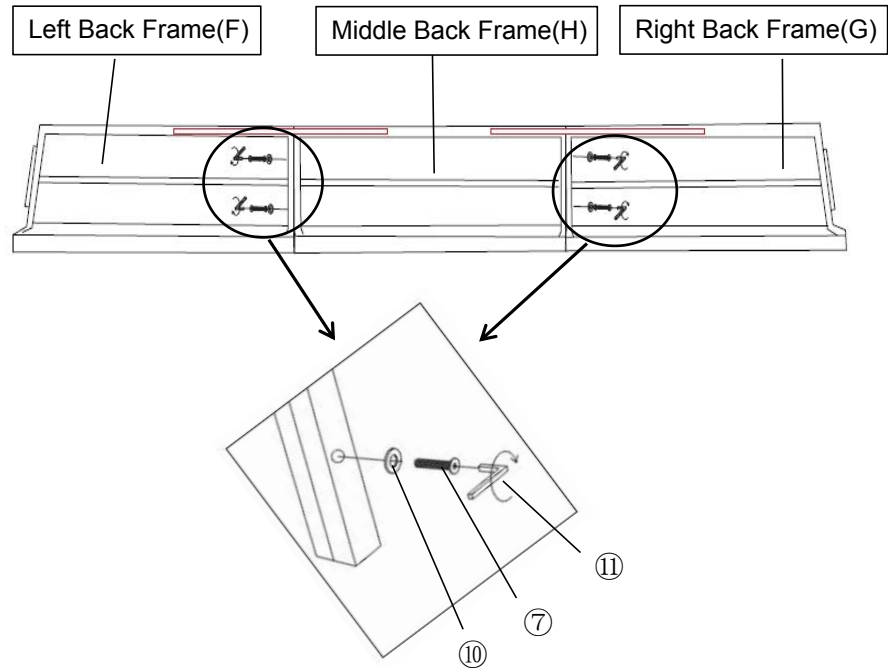

Locking the Back Frame by using Bolt (7), Flat Washer (10), with Allen Wrench (11) turning clockwise until tight.

Step 7

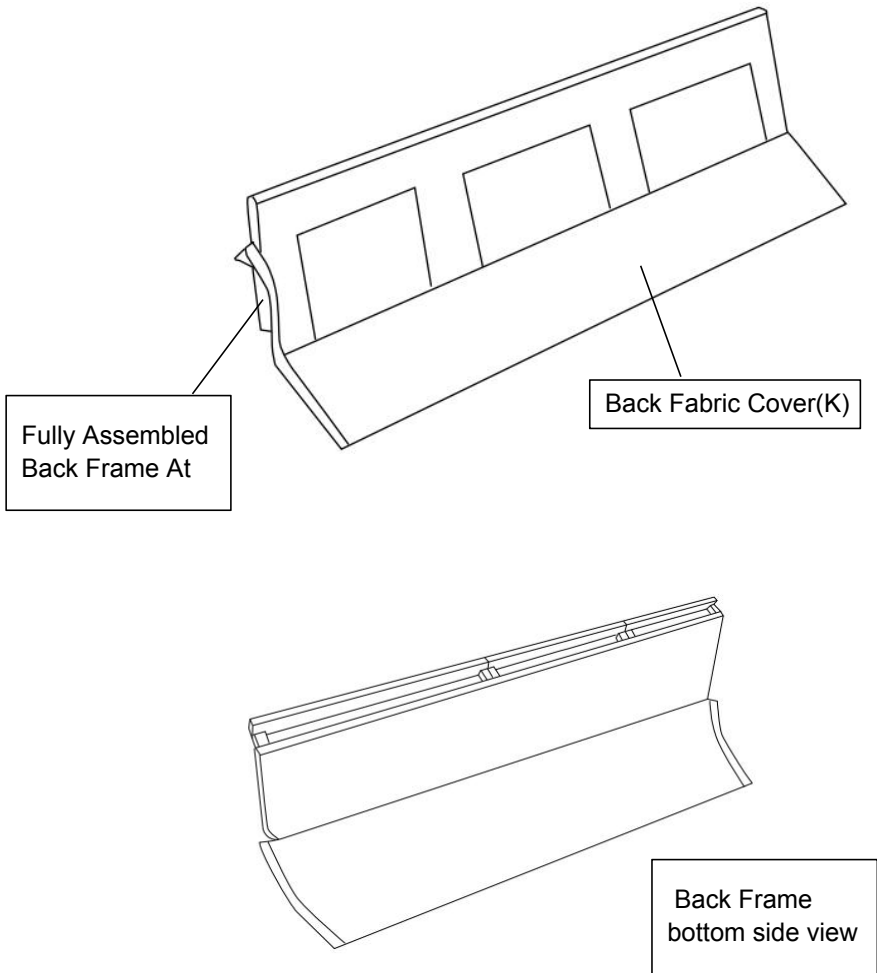

Put Back Fabric Cover (K) into the Fully Assembled Back Frame as shown in the picture.

Step 8

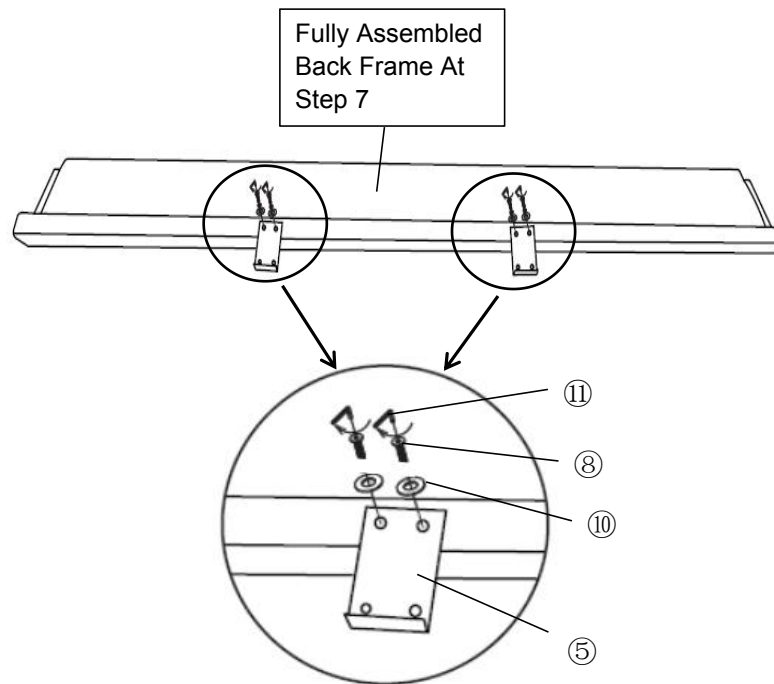

Install the Back Leg Installation Piece(5) on the Fully Assembled Back Frame by using Bolt(8), Flat Washer(10) with Allen Wrench(11) turning clockwise until tight.

Step 9

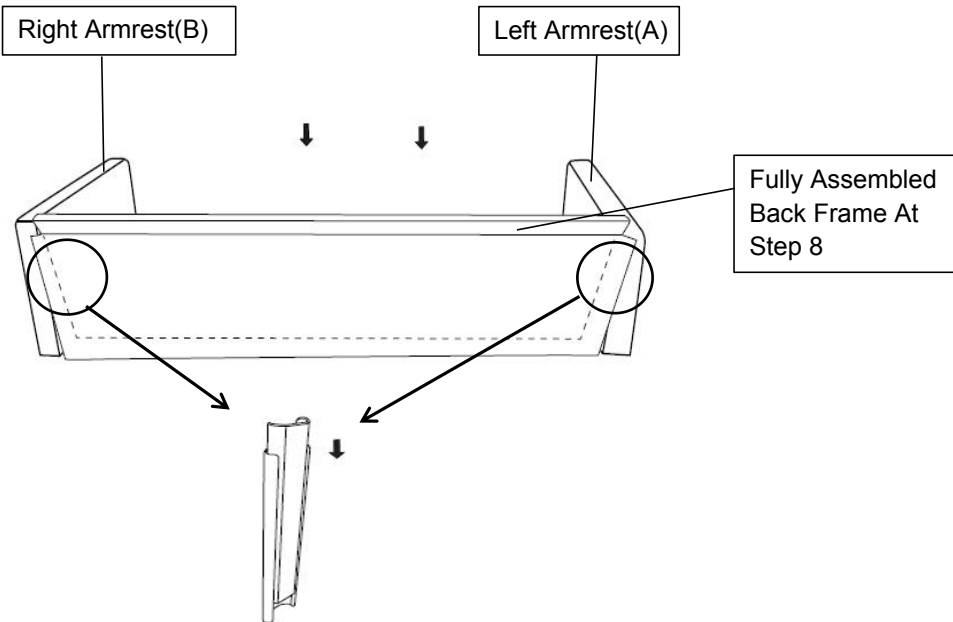

Slide the Tapered Connectors on the Fully Assembled Back Frame into the Tapered Connectors on the Left Armrest(A) and Right Armrest(B) as shown in the picture.

Note: Make sure the Tapered Connectors on Back Frame lock into the Tapered Connectors on the Left Armrest(A) and Right Armrest(B). Assistance from an adult partner is necessary for this assembly process.

During this assembly process - do exercise caution. You may need to use your hand to press down and or pave away the padded surface to facilitate the 'slip and slide' assembly.

Caution: Ensure that your fingers do not get caught or pinched in the assembly process.

Step 10

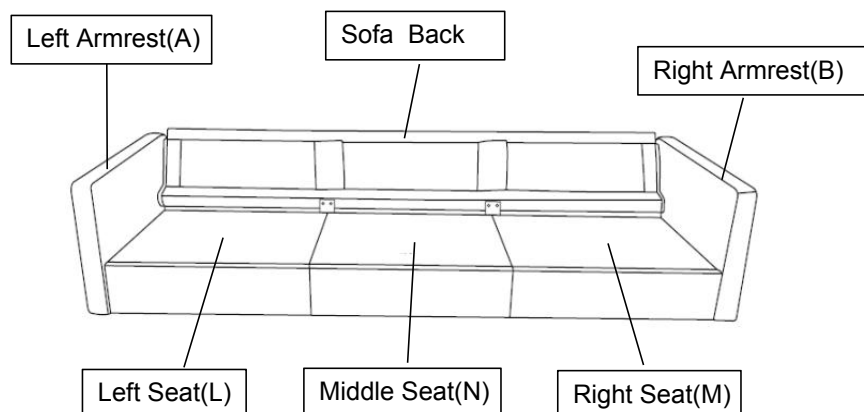

Put Left Seat(L), Middle Seat(N), and Right Seat(M) on the Sofa.

Note: Please pay attention to the hole on Middle Seat(N) which matched on the front and back.

Step 11

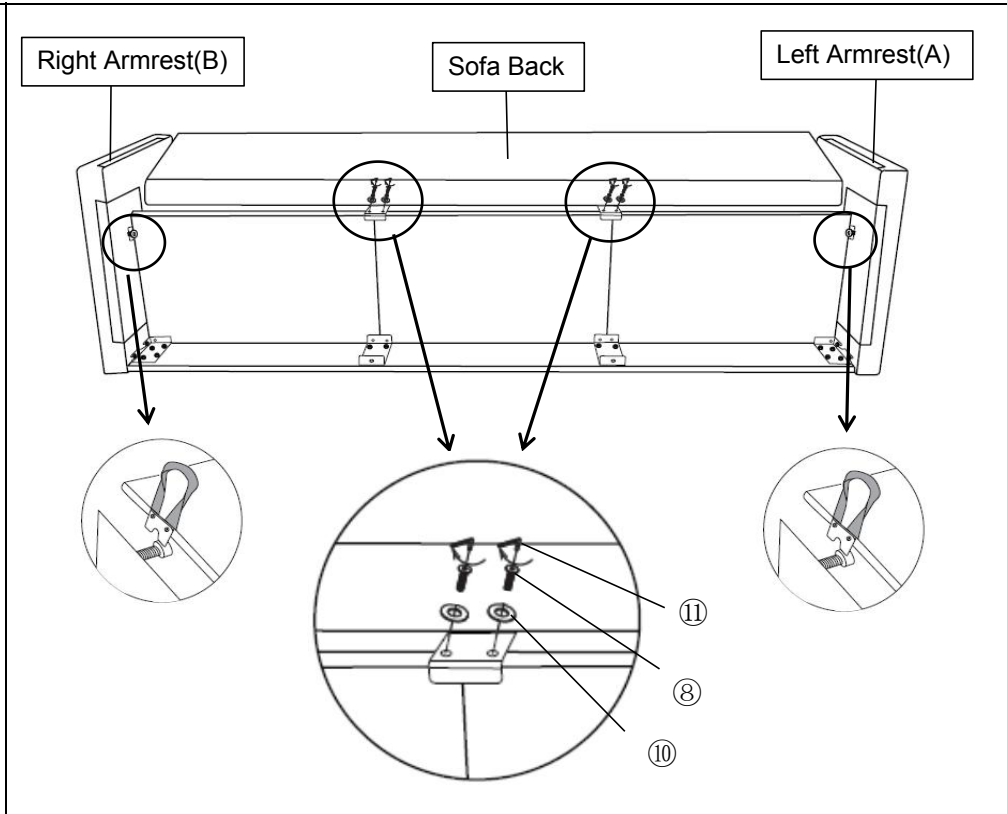

Position the sofa back up, the u-shaped iron sheet need clamped to the bolt on the Left Armrest(A) and Right Armrest(B).
Locking the seat and back together by using Bolt(8), Flat Washer(10) with Allen Wrench(11) turning clockwise until tight.

Step 12

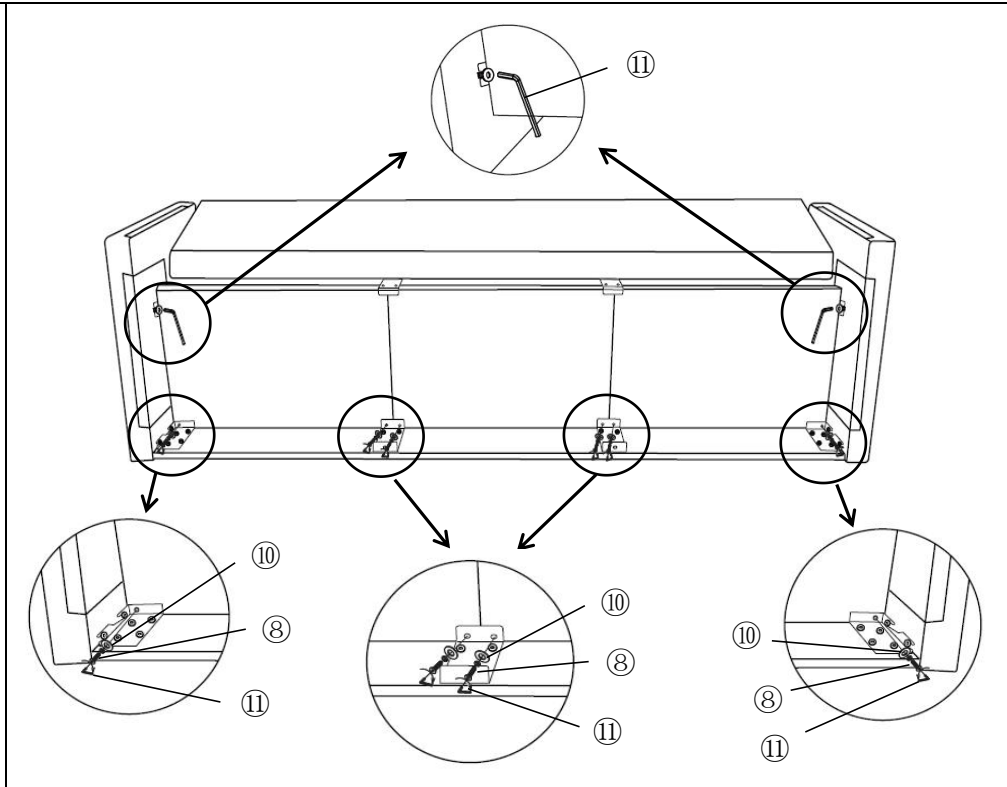

Locking the seat and Front together by using Bolt(8), Flat Washer(10) with Allen Wrench(11) turning clockwise until tight.
Also locking the Bolt on the Arms.

Step 13

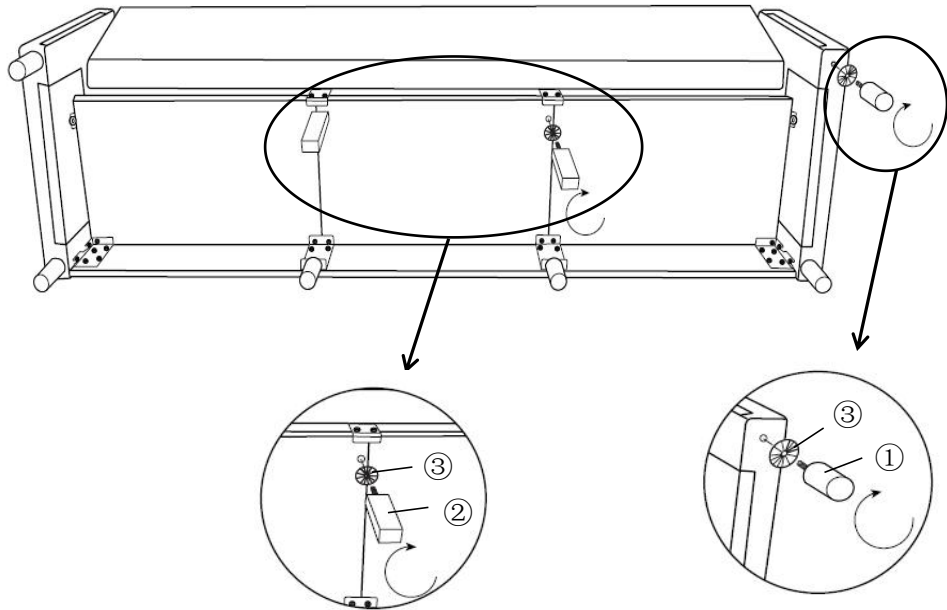

Install the Leg(①) and Middle Leg(②) at the bottom of Sofa by placing Plastic Washer(③) on the threaded stem. Then insert threaded stem into the threaded mounting position at the bottom of Sofa. Tighten by turning the Leg clockwise.

Note: The use of Plastic Washer(①) are OPTIONAL and are especially useful to help alleviate light wobbles. Some Legs may need more than one whilst some legs may not need any.

Step 14

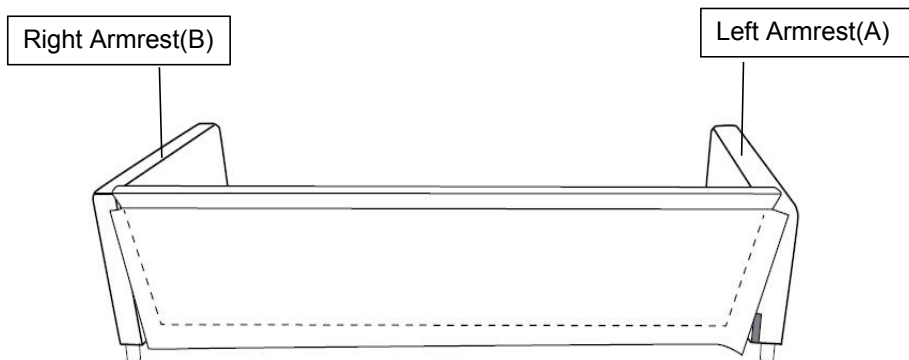

Stick the magic tape on the Back Fabric Cover(K) to Left Armrest(A) and Right Armrest (B).

Step 15

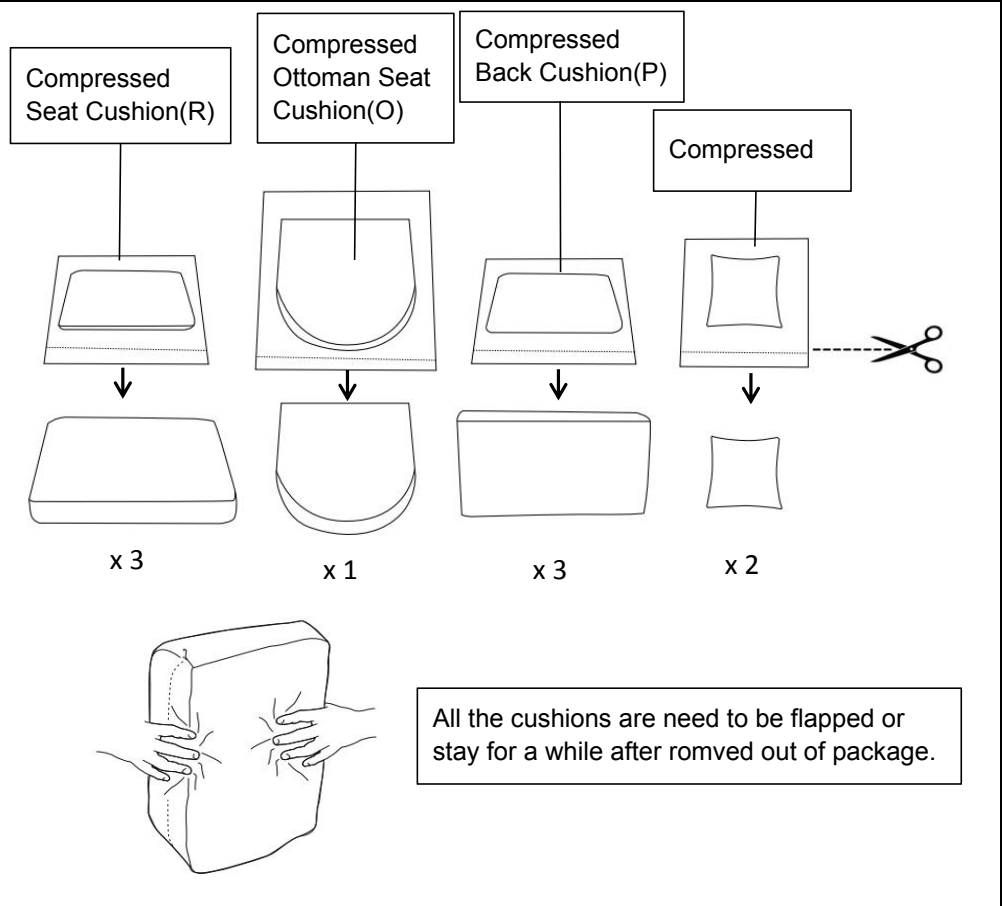

Cut all the Compressed packages and remove out cushions.

Step 16

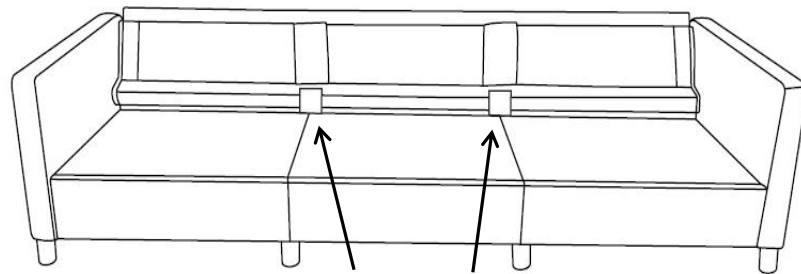

Cover the Back Leg Installation Piece by pre-sewing fabric.

Step 17

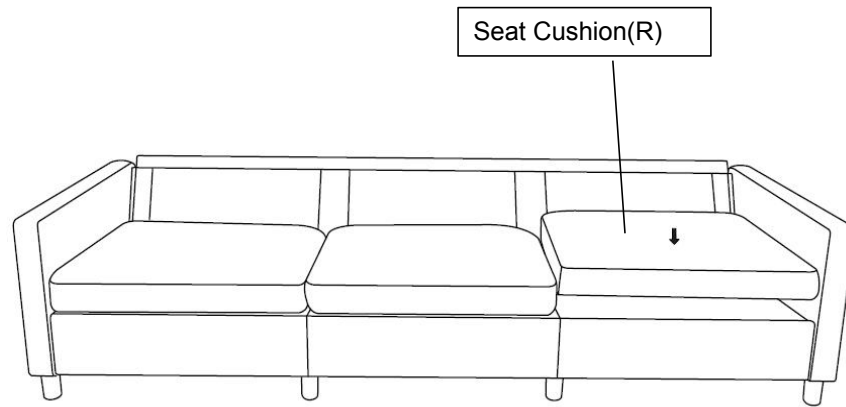

Put Seat Cushion(R) on the sofa.

Step 18

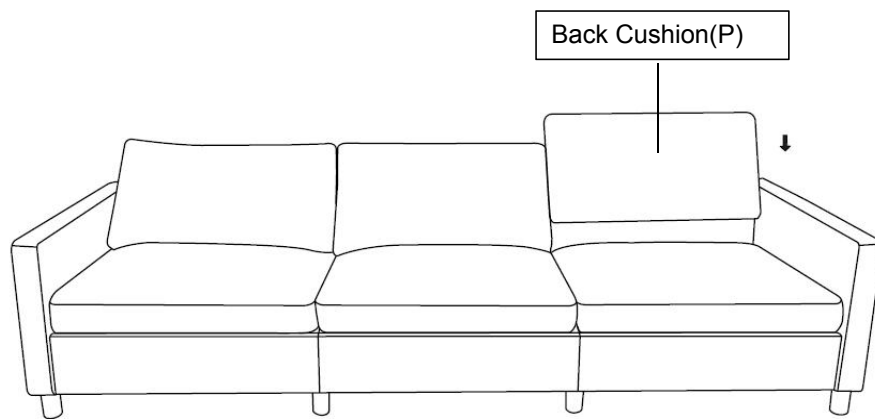

Put Back Cushion(P) on the sofa.

Step 19

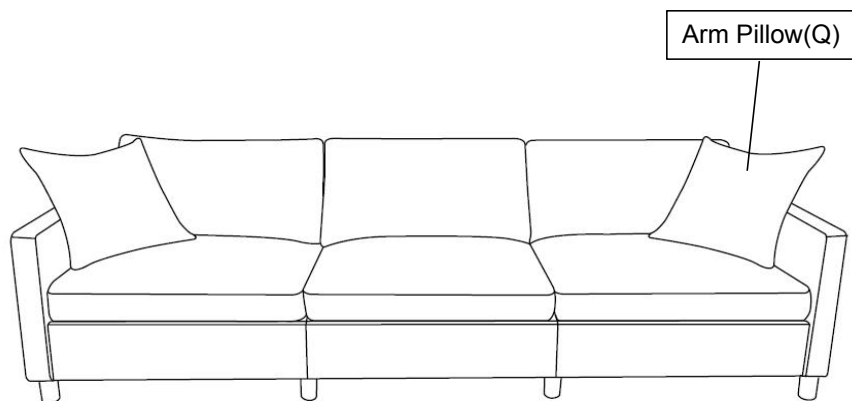

Put Arm Pillow(Q) on the sofa.

Step 20

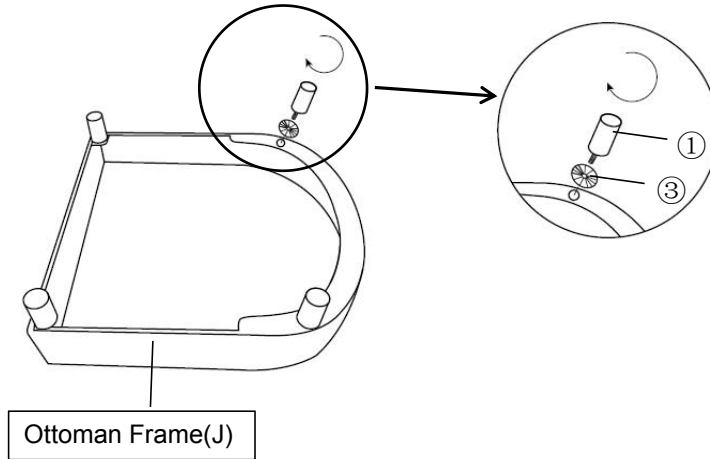

Install the Leg(①) at the bottom of Sofa by placing Plastic Washer(③) on the threaded stem. Then insert threaded stem into the threaded mounting position at the bottom of Sofa. Tighten by turning the Leg clockwise.
Note: The use of Plastic Washer(①) are OPTIONAL and are especially useful to help alleviate slight wobbles. Some Legs may need more than one whilst some legs may not need any.

Step 21

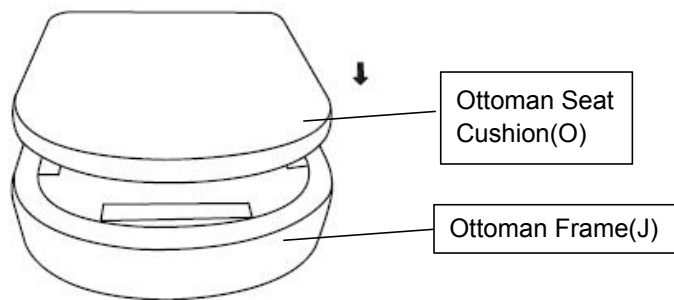

Put Ottoman Seat Cushion(O) on the sofa.



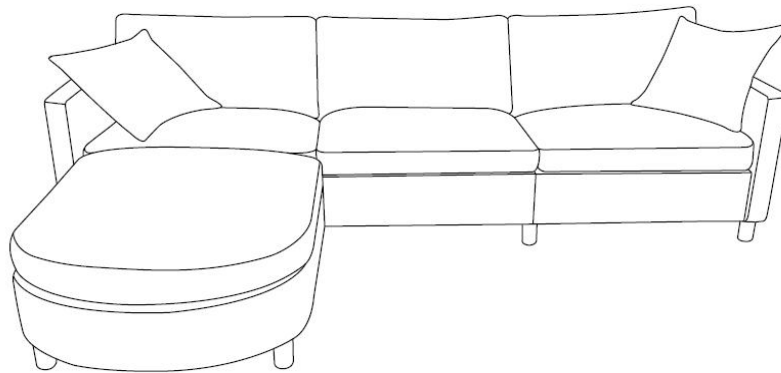
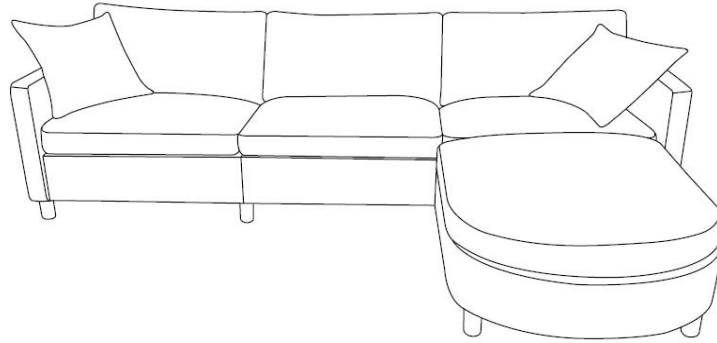







Step 22



Your SOFA is ready to use.
This SOFA can only be used on a flat, level surface.
The Ottoman can use in both left or right side.



Care & Maintenance

- ✓  • Furniture may scratch floors. We recommend using furniture pads to protect your floors.
- ⊘  • Do not put hot items directly on furniture surface.
- ⊘  • Do not clean furniture with harsh cleansers or polish.
- ⊘  • Do not place furniture under direct sunlight.
- ⊘  • Do not place furniture near heating or cooling vents.
- ⊘  • Do not write on furniture without a padded barrier to protect the surface.
- ⊘  • Do not place furniture outside . For indoor use only.
- ⊘  • Not for commercial use. For residential use only.
- ⊘  • Stains may be removed with mild soap solution and damp cloth.
- ⊘  • Children should not climb or jump on the furniture.
- ✓  • Dust and pick-up spills using a clean, non-colored, lint-free cloth.