

**INSTRUCTIONS**

**INSTRUCTION**

**ANWEISUNG**

**取扱説明書**

**사용설명서**

**ISTRUZIONI PER L'INSTALLAZIONE**

**LIBRO DE INSTRUCCIONES**

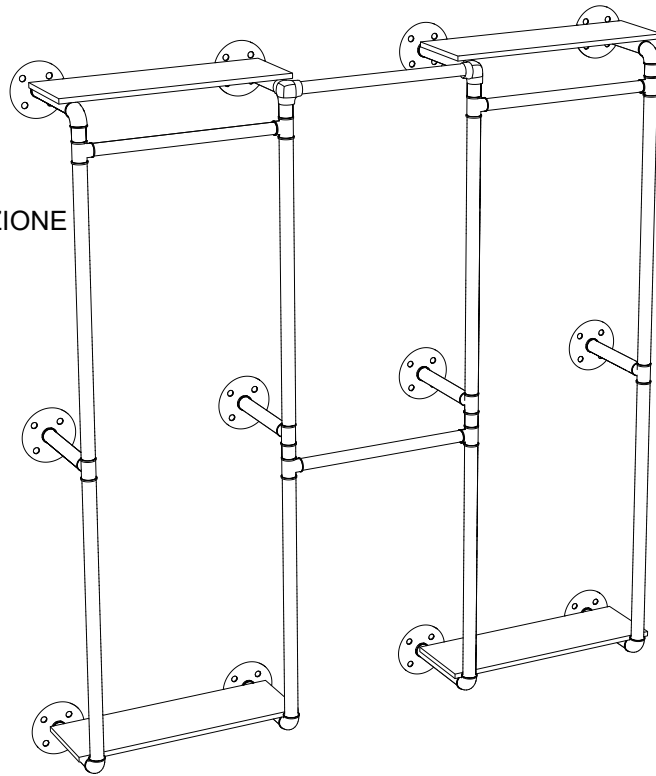

**Warning:**

Avoid climbing by children

Vorsichtig, dass Sie nicht von den Waren erdrückt werden.

Empêcher les marchandises de basculer et de heurter les personnes

Evitare che le merci si ribaltino e colpiscano le persone

Evitar que la carga caiga sobre las personas

子供が登らないようにしてください。

아이들이 올라가지 않도록 하세요.

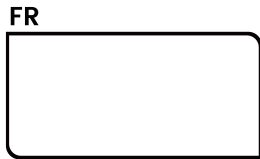
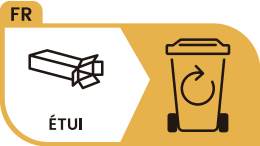

**A \*4**

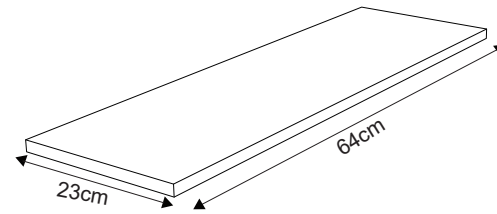

**B \*4**



**C \*12**

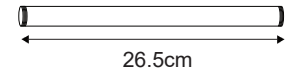

**D \*4**

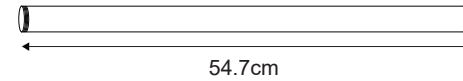

**E \*8**

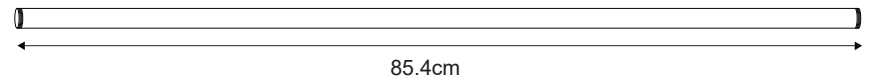

**F \*6**

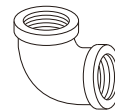

**G \*2**



**H \*8**

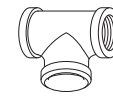

**J \*2**

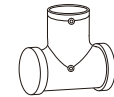

**K \*12**

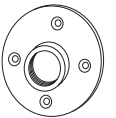

**L \*16**



**M \*48**

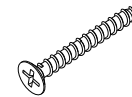

**N \*48**



**O \*8**



**P \*1**



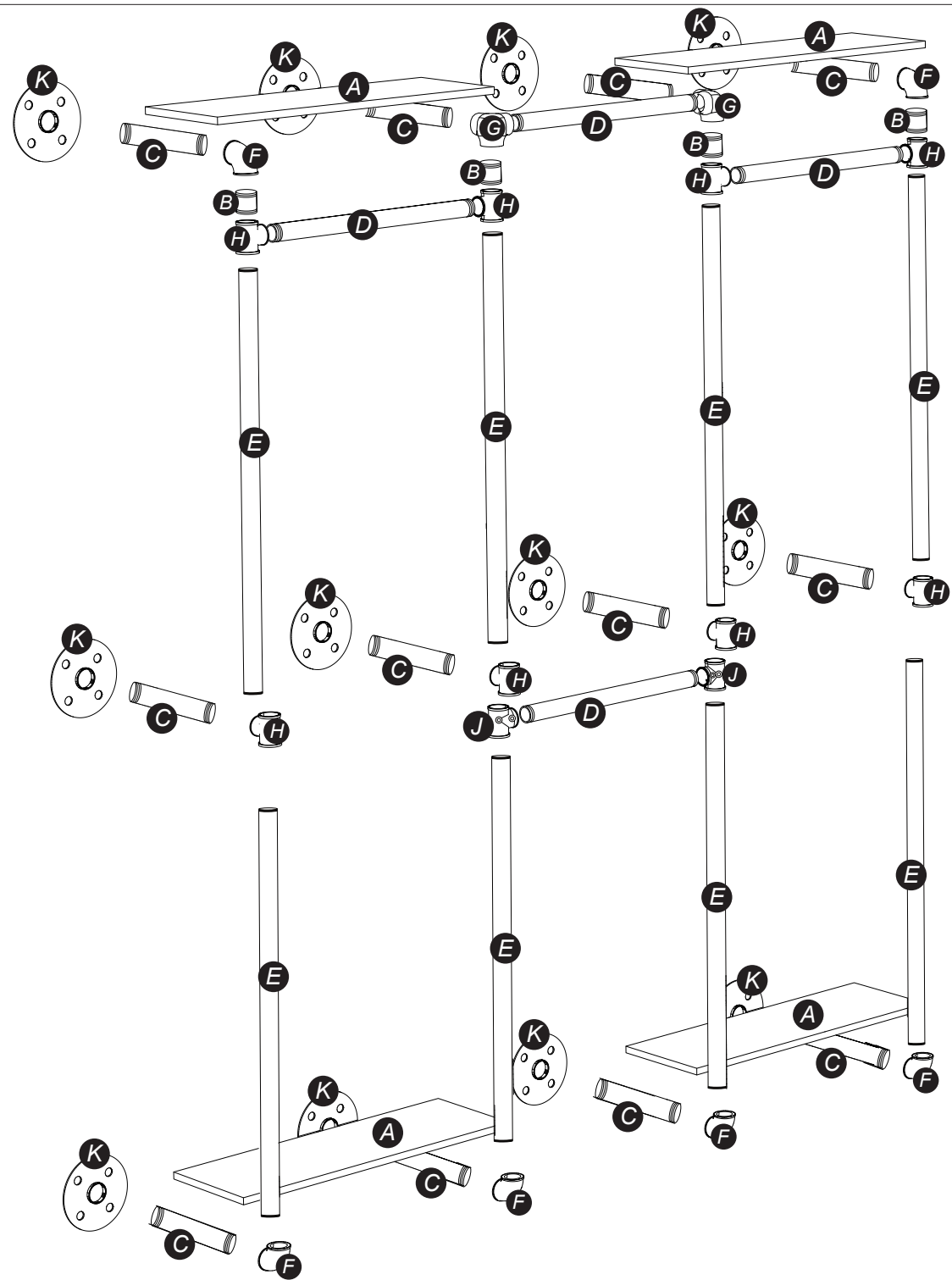

1

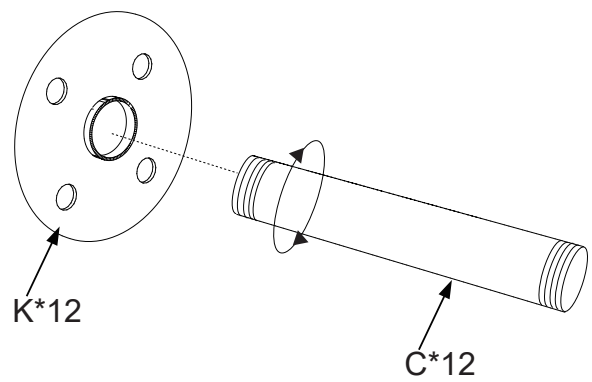

2

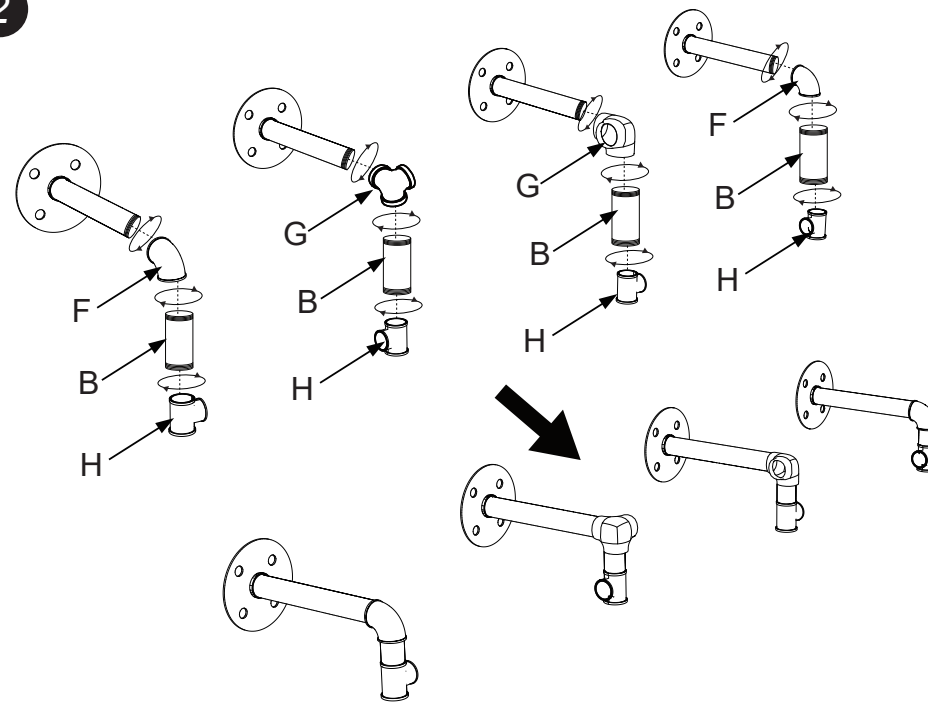

3

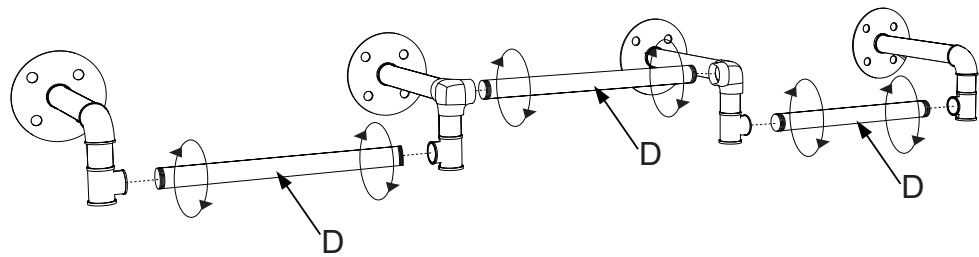

4

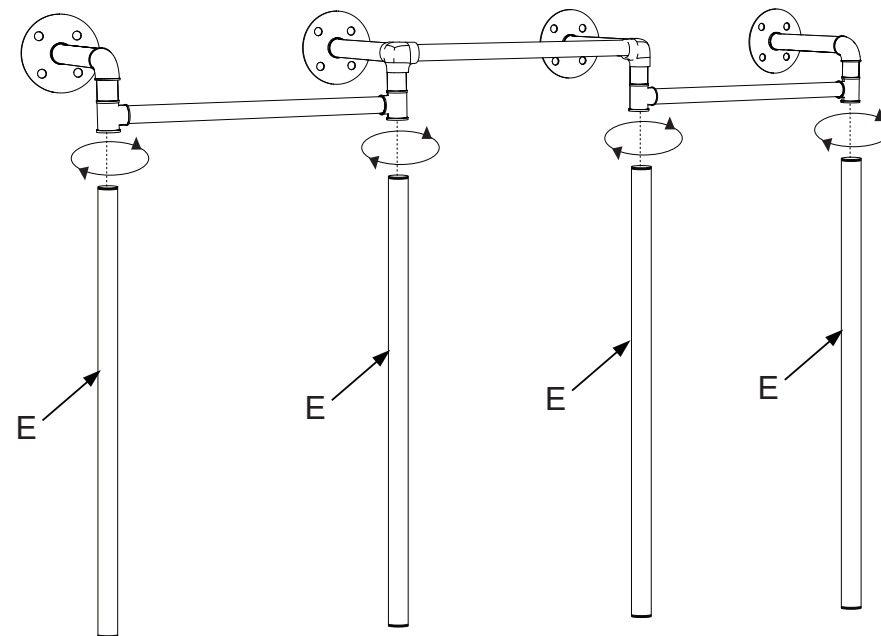

5

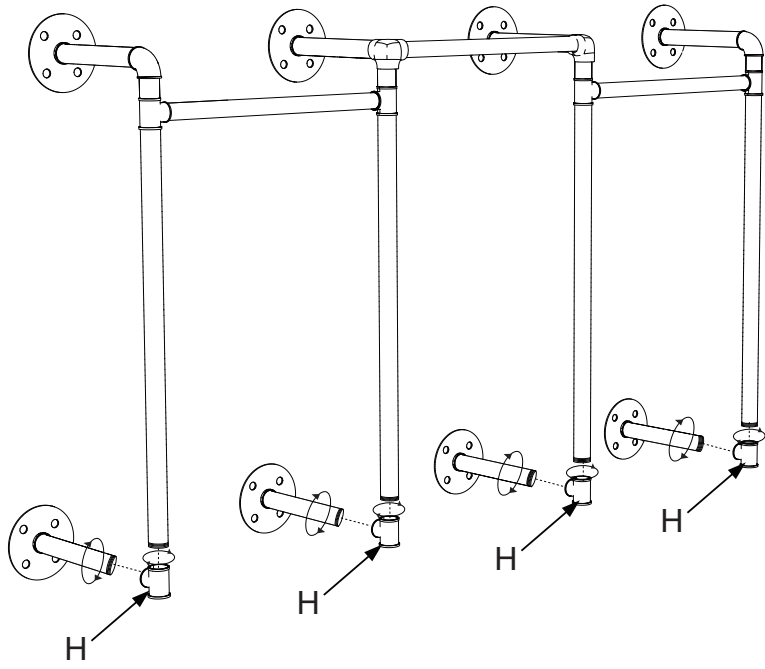

6

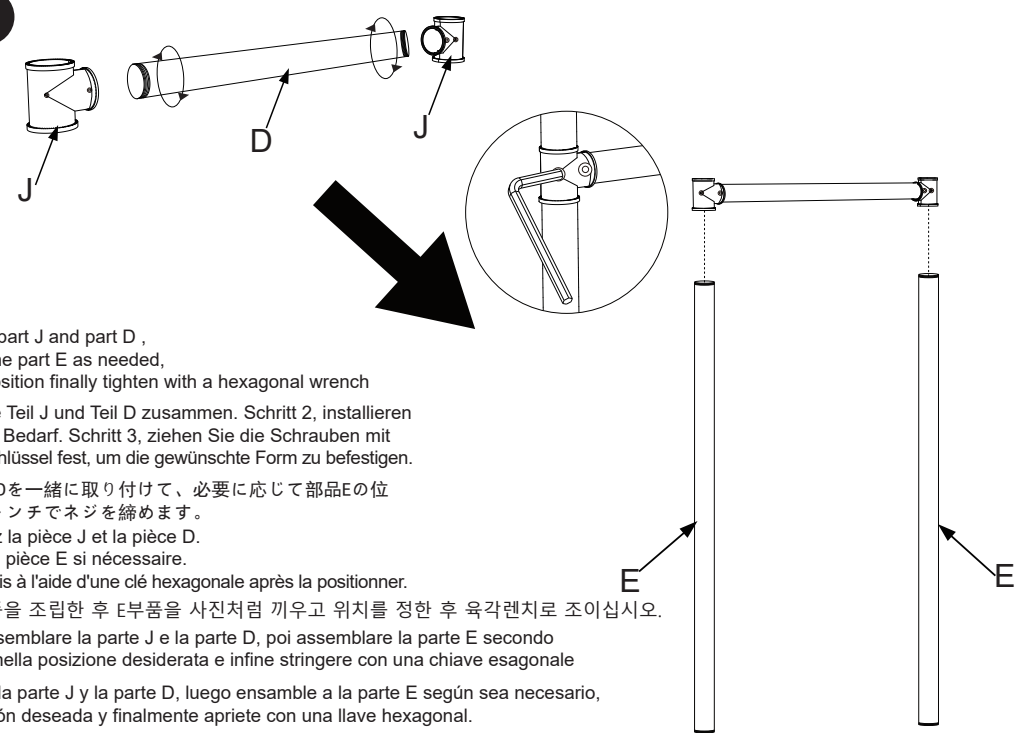

First assemble the part J and part D ,  
 then assemble to the part E as needed,  
 fix it to a desired position finally tighten with a hexagonal wrench

Schritt 1, bauen Sie Teil J und Teil D zusammen. Schritt 2, installieren Sie den Teil E nach Bedarf. Schritt 3, ziehen Sie die Schrauben mit einem Schraubenschlüssel fest, um die gewünschte Form zu befestigen.

まず、部品Jと部品Dを一緒に取り付けて、必要に応じて部品Eの位置を調整した後、レンチでネジを締めます。

Étape 1, Assemblez la pièce J et la pièce D.  
 Étape 2, Installez la pièce E si nécessaire.  
 Étape 3, Serrer les vis à l'aide d'une clé hexagonale après la positionner.

먼저 J부품과 D부품을 조립한 후 E부품을 사진처럼 끼우고 위치를 정한 후 육각렌치로 조이십시오.

Per prima cosa, assemblare la parte J e la parte D, poi assemblare la parte E secondo necessità, fissarla nella posizione desiderata e infine stringere con una chiave esagonale

Primero ensamble la parte J y la parte D, luego ensamble a la parte E según sea necesario, fijelo en una posición deseada y finalmente apriete con una llave hexagonal.

7

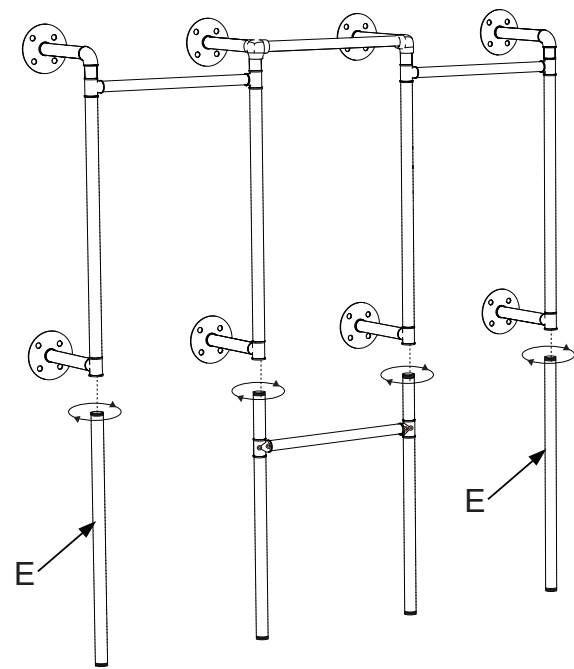

8

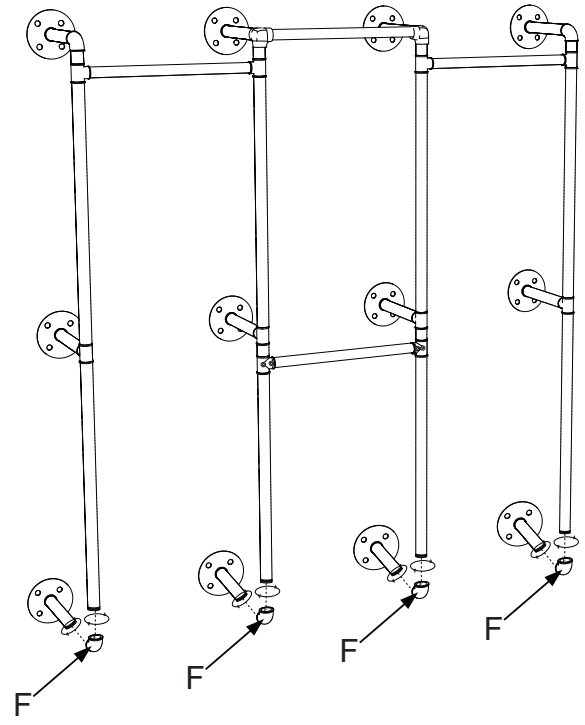

9

L \*16 

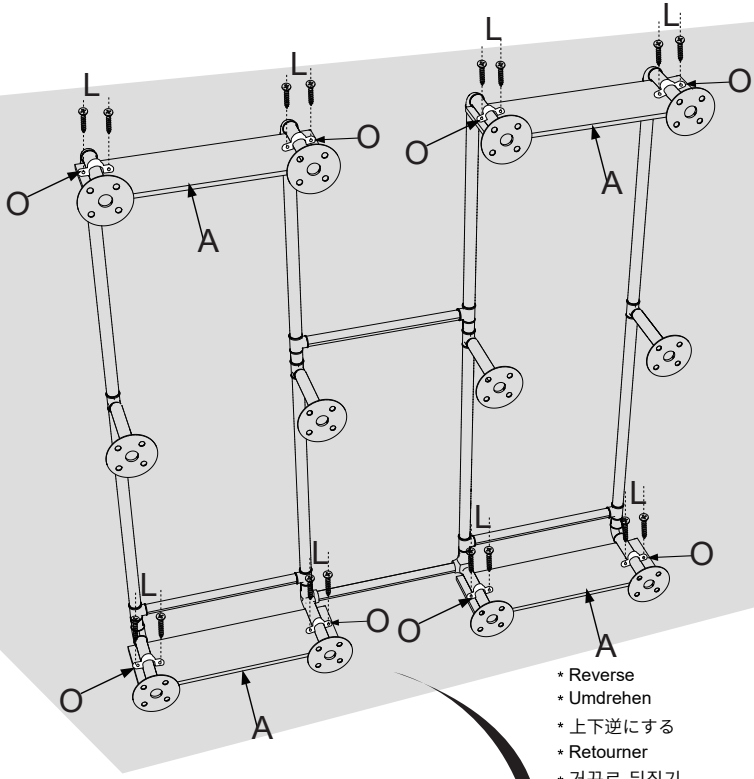

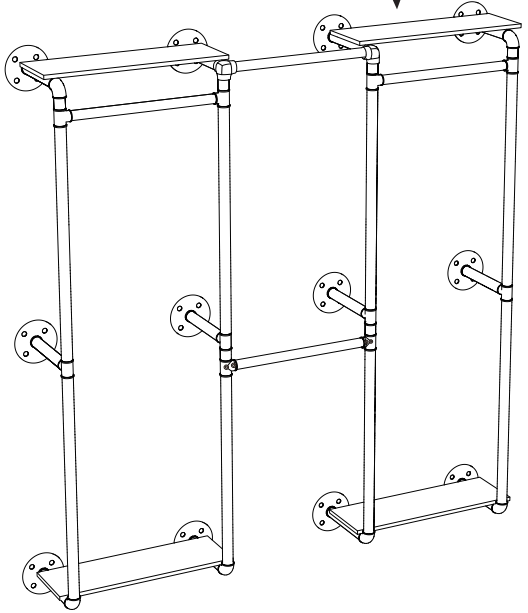

Ground  
Boden  
フロア  
Par terre  
바닥  
Suolo

- \* Reverse
- \* Umdrehen
- \* 上下逆にする
- \* Retourner
- \* 거꾸로 뒤집기
- \* Ribaltare
- \* Reverso



10

M *48 	N *48 
---	---

- ▶ Brick wall ▶ Ziegelwand ▶ Mur de briques ▶ 시멘트 벽 ▶ Muro di mattoni ▶ Muro de ladrillo
- ▶ Concrete wall: use a 10 mm diameter drill bit
- ▶ Betonwand: Verwenden Sie einen Bohrer mit einem Durchmesser von 10 mm.
- ▶ 콘크리트벽: 10mm径のドリルビットを使う
- ▶ Mur en béton : utiliser un foret de 10 mm de diamètre
- ▶ 콘크리트 벽: 10mm 직경의 드릴 비트를 사용하세요
- ▶ Pared de concreto: usar una broca de 10 mm de diámetro.
- ▶ Muro di cemento: utilizzare una punta da trapano di 10 mm di diametro.

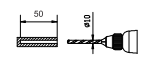

- ▶ Wood wall ▶ Holzwandl ▶ Mur de bois ▶ 나무 벽 ▶ Muro di legno ▶ Muro de madera
- ▶ Wooden post wall: use a 6 mm diameter drill bit.
- ▶ Holzpostenwand: Verwenden Sie einen Bohrer mit einem Durchmesser von 6 mm
- ▶ 木柱壁: 6mm径のドリルビットを使う
- ▶ 목재 기둥 벽: 6mm 직경의 드릴 비트를 사용하세요
- ▶ Mur en poteaux de bois : utiliser un foret de 6 mm de diamètre
- ▶ Muro in pali di legno: utilizzare una punta da trapano di 6 mm di diametro
- ▶ Muro de postes de madera: usar una broca de 6 mm de diámetro

