

ASSEMBLY INSTRUCTION



This instruction booklet contains important safety information. please read and keep for future reference.

This sofa collection work as modular sofa function,it can be 2seater sofas,3seater sofas,4seater sofas,L shape sofas,ottoman,sofa sets with buying different sections of the sofas and combine them together.You can decide to buy more components according to your living room size.

To ensure safe and satisfactory use of this product,please carefully read the below instructions beforehand.

- 1.This sofa ships in several boxes,we recommend unpacking and starting assembly when several boxes are received.
- 2.Our cushions are vacuum packed for convenient shipping. Please allow 2-3days for them to fully expand to their original shape and for any wrinkles to disappear.
- 3.In the event that a part is damaged or missing,no need to return the product,we will gladly help and ship your replacement parts free of charge.

Below are some guidelines for you how you can do mix and match.

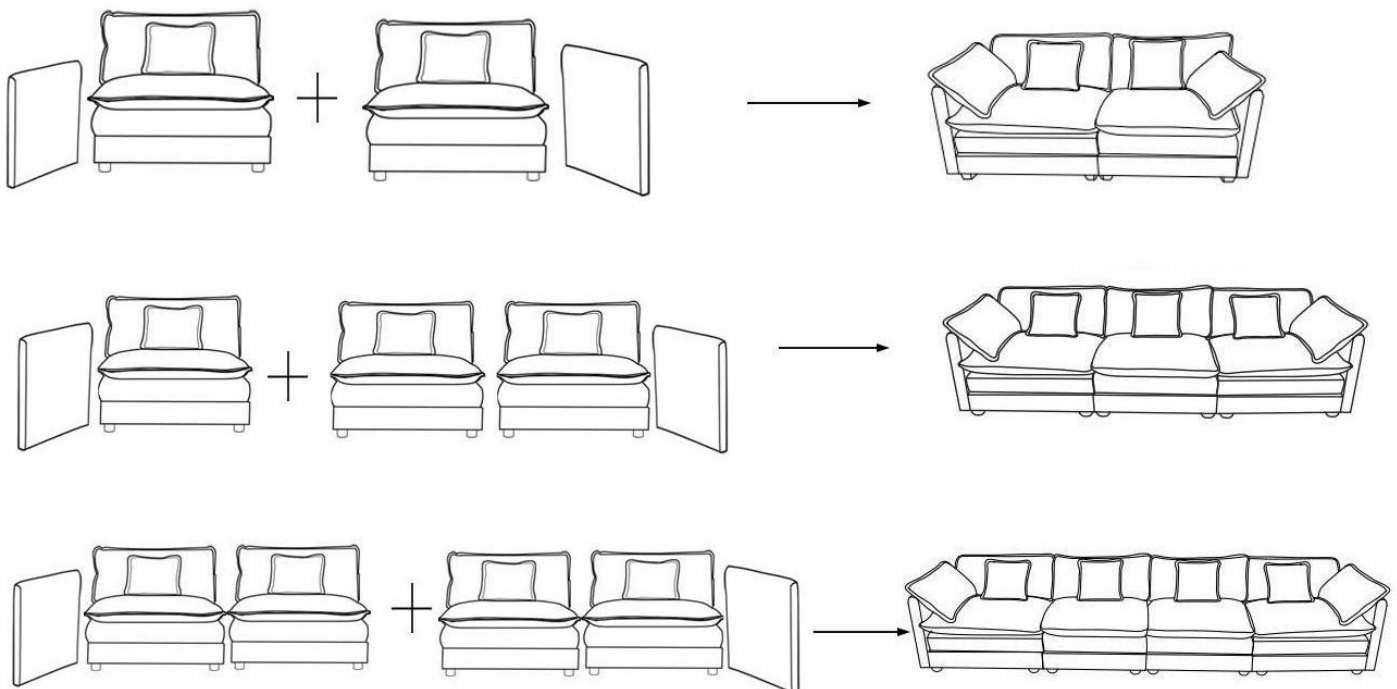



• Read instructions, cover to cover



• Have 2 adults on hand for assembly



• Do not assemble on flooring or carpet



• Assemble on a clean non-marring surface (packing foam)











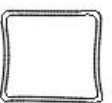

• Save all packaging until finished





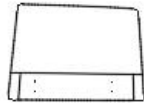

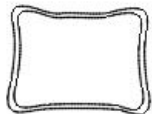







IF YOU BUY 2 SEATER SOFA
please follow below assembly instruction

Parts incidued

Parts List (BOX 1-LEFT)

<p>A Seat frame</p>  <p>1PC</p>	<p>B Seat cushion</p>  <p>1PC</p>	<p>C Back Cushion</p>  <p>1PC</p>	<p>E Pillow</p>  <p>1PC</p>
<p>F Backrest</p>  <p>1PC</p>	<p>G Leg</p>  <p>4PC</p>	<p>L Gasket</p>  <p>4PCS</p>	<p>N Gasket</p>  <p>8 PCS</p>
<p>O M8*60mm Bolt</p>  <p>4PCS</p>	<p>H Left armrest</p>  <p>1PC</p>	<p>S M8*50mm Bolt</p>  <p>4PCS</p>	<p>D Arm pillow</p>  <p>1PC</p>

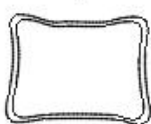
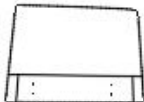
Parts List (BOX 2-RIGHT)

<p>A Seat frame</p>  <p>1PC</p>	<p>B Seat cushion</p>  <p>1PC</p>	<p>C Back Cushion</p>  <p>1PC</p>	<p>E Pillow</p>  <p>1PC</p>
<p>F Backrest</p>  <p>1PC</p>	<p>G Leg</p>  <p>4PC</p>	<p>L Gasket</p>  <p>4PCS</p>	<p>N Gasket</p>  <p>16PCS</p>
<p>O M8*60mm Bolt</p>  <p>4PCS</p>	<p>P M8*90mm Bolt</p>  <p>4PCS</p>	<p>R Alley Key</p>  <p>1PC</p>	<p>Q Butterfiy Nut</p>  <p>4PCS</p>
<p>D Arm pillow</p>  <p>1PC</p>	<p>I Right armrest</p>  <p>1PC</p>	<p>S M8*50mm Bolt</p>  <p>4PCS</p>	

ASSEMBLY STEPS

STEP 1: Assemble the Left armrest (H) to the Seat frame (A) with Washers (N) and Bolts (S).

B0X1-LEFT

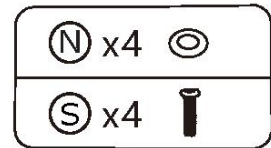
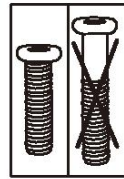
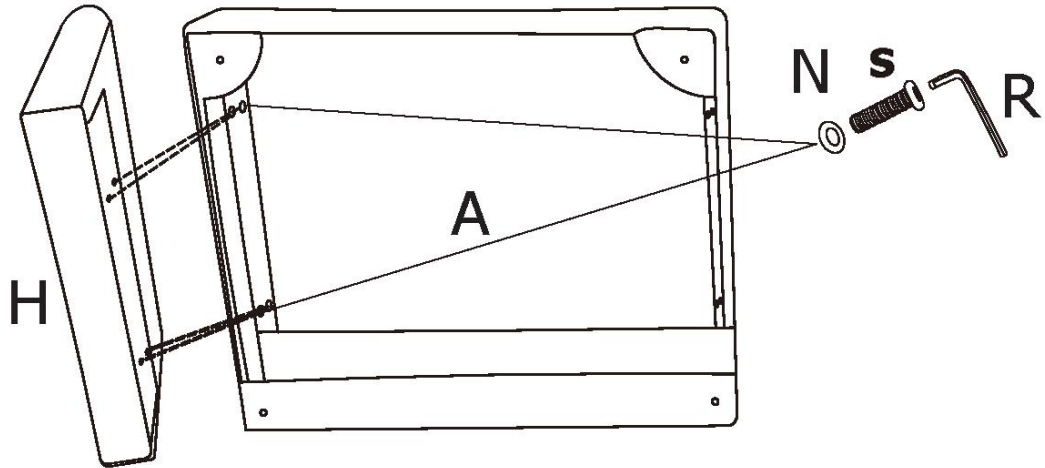

STEP 2: Assemble the Right armrest (I) to the Seat frame (A) with Washers (N) and Bolts (S).

B0X2-RIGHT

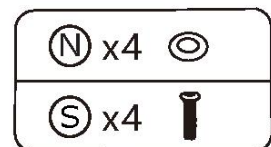
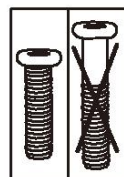
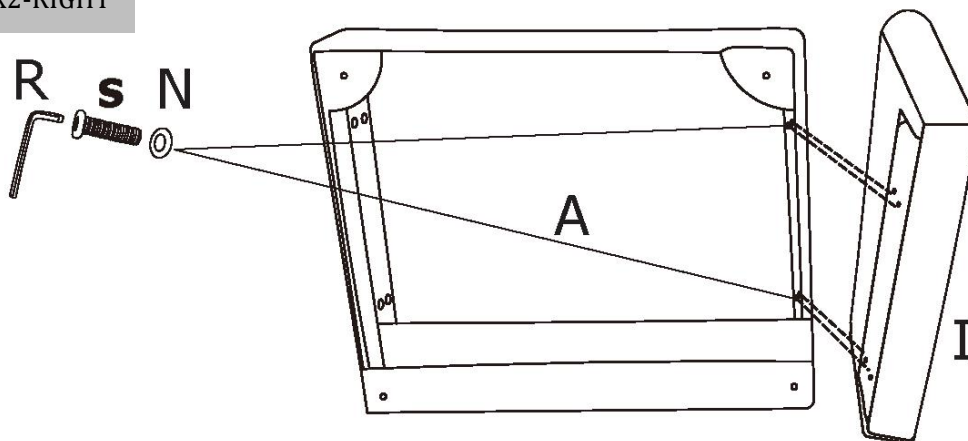

STEP 3: Assemble Seat frame (A) and Seat frame (A) with Butterfly nuts (Q) Washers (N) and Bolts (P).

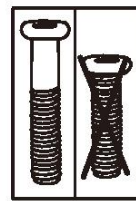
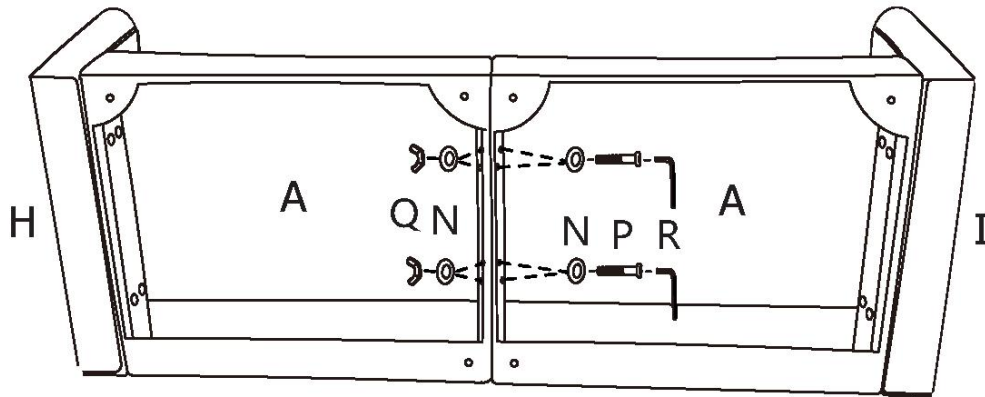

(N)	8	(N)
(P) x 4		(P)
(Q) x 4		(Q)

STEP 4: Assemble the Legs (G) on the sofa with Gaskets (L).

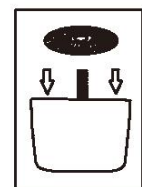
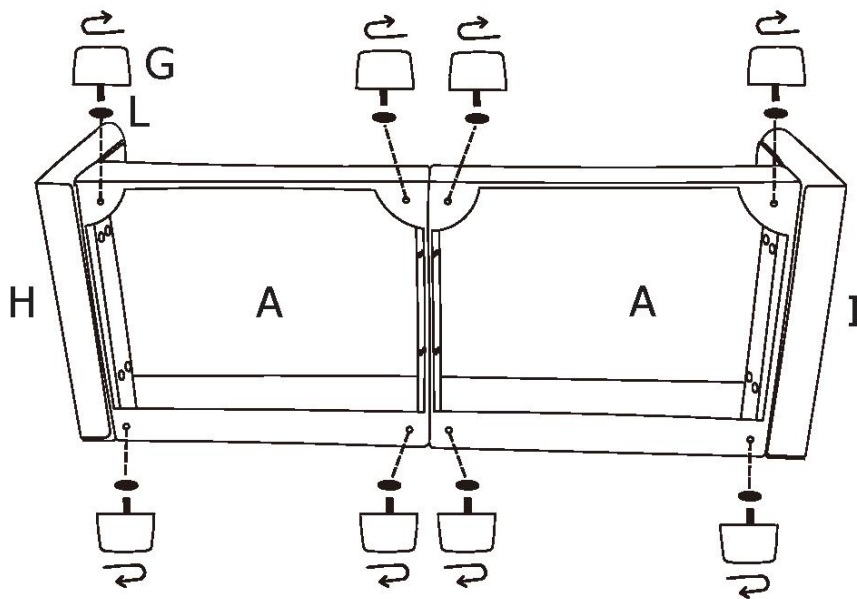

STEP 5: Insert the Backrest (F) into the designated holes, using Washer (N) and Bolts (O) to 70% tightness, and then tighten the all Bolts on the seat.

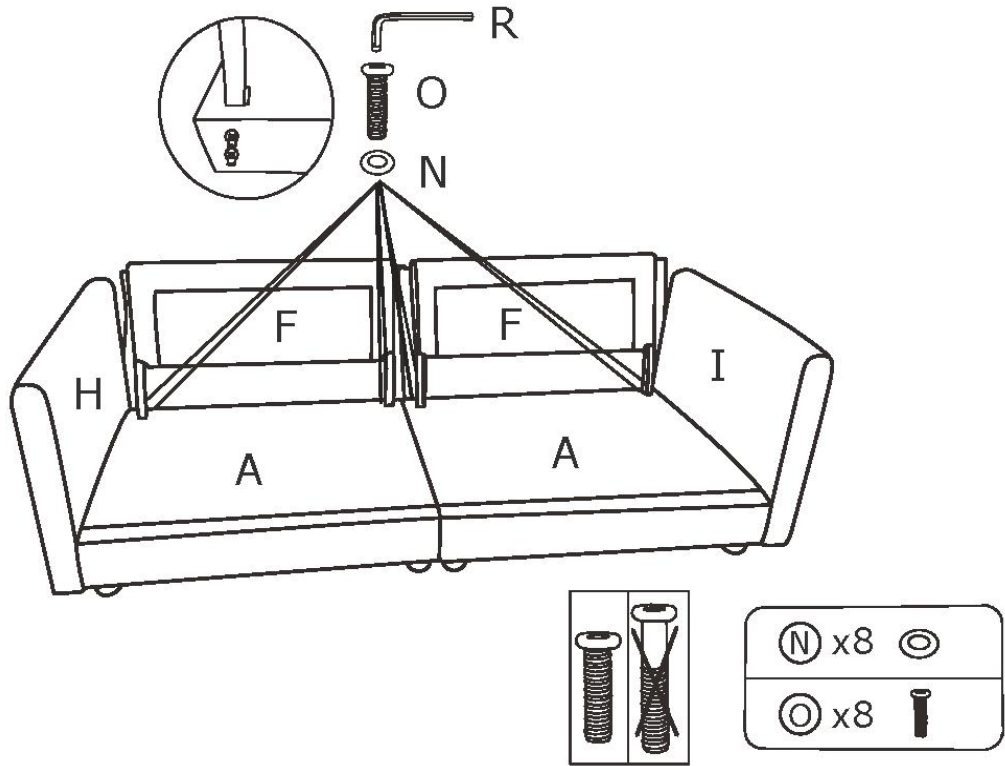

STEP 6: The cushion is packaged by vacuum compression. After cutting the package, it rebounds quickly within 4 hours. If the fabric has wrinkles, it will basically disappear after standing for 72 hours

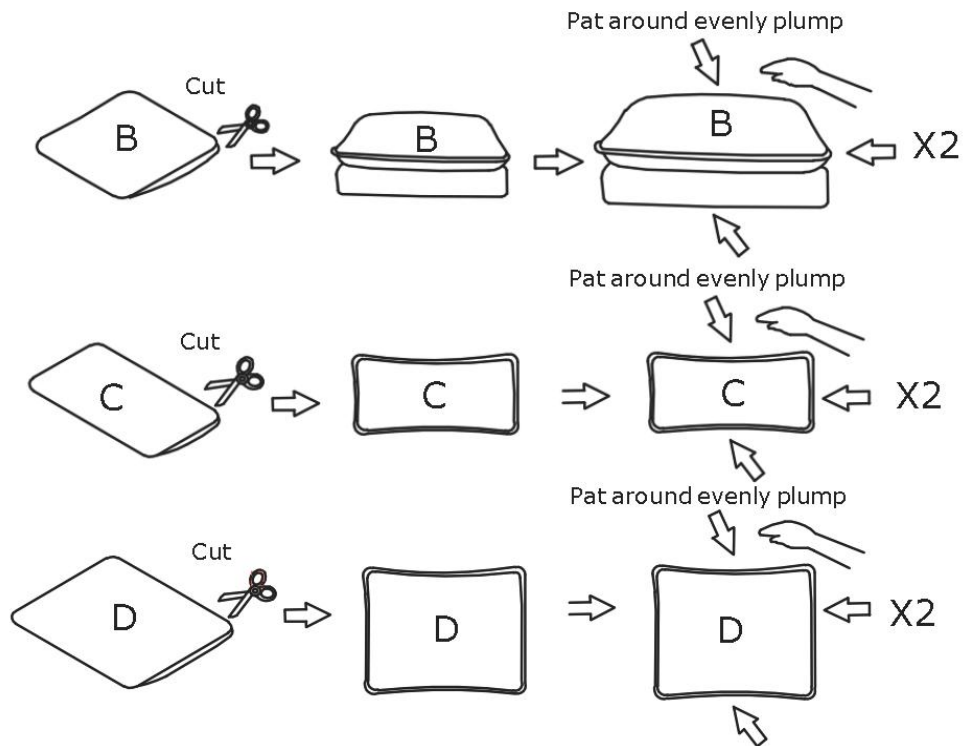

STEP 7: Place Seat cushions (B) and back cushions (C), on the sofa and make sure it's will fitted.

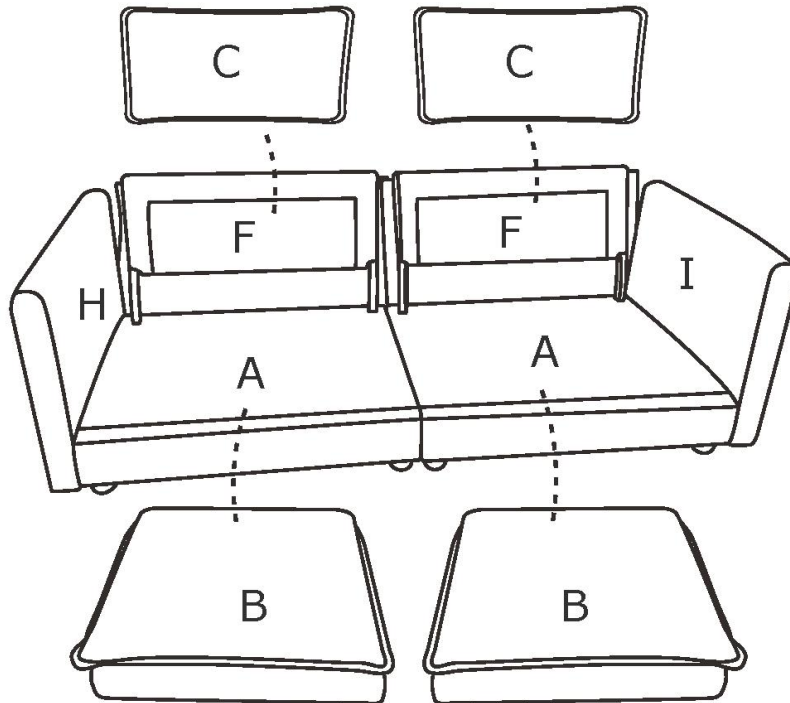



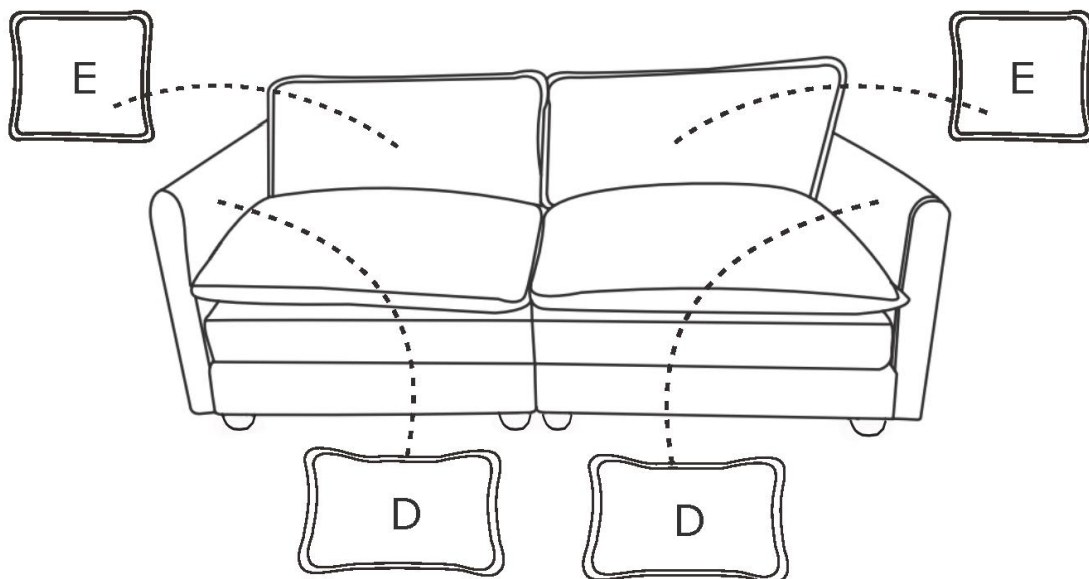







STEP 8: Place Pillows (E) and Pillows (D) on sofa and make sure it's will fitted.









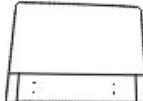
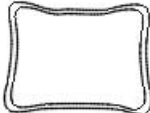





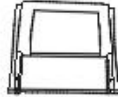

IF YOU BUY 3 SEATER SOFA
please follow below assembly instruction

Parts incidued





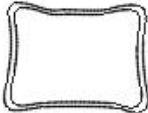
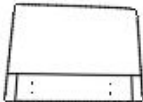



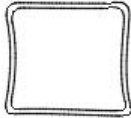
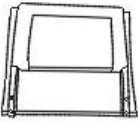

Parts List (BOX 1-LEFT)

<p>(A) Seat frame</p>  <p>1PC</p>	<p>(B) Seat cushion</p>  <p>1PC</p>	<p>(C) Back Cushion</p>  <p>1PC</p>	<p>(E) Pillow</p>  <p>1PC</p>
<p>(F) Backrest</p>  <p>1PC</p>	<p>(G) Leg</p>  <p>4PC</p>	<p>(L) Gasket</p>  <p>4PCS</p>	<p>(N) Gasket</p>  <p>8 PCS</p>
<p>(O) M8*60mm Bolt</p>  <p>4PCS</p>	<p>(S) M8*50mm Bolt</p>  <p>4PCS</p>	<p>(H) Left armrest</p>  <p>1PC</p>	<p>(D) Arm pillow</p>  <p>1PC</p>

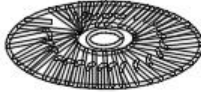
Parts List (BOX 2-RIGHT)

<p>(A) Seat frame</p>  <p>1PC</p>	<p>(B) Seat cushion</p>  <p>1PC</p>	<p>(C) Back Cushion</p>  <p>1PC</p>	<p>(E) Pillow</p>  <p>1PC</p>
<p>(F) Backrest</p>  <p>1PC</p>	<p>(G) Leg</p>  <p>4PC</p>	<p>(L) Gasket</p>  <p>4PCS</p>	<p>(N) Gasket</p>  <p>16PCS</p>
<p>(O) M8*60mm Bolt</p>  <p>4PCS</p>	<p>(P) M8*90mm Bolt</p>  <p>4PCS</p>	<p>(R) Alley Key</p>  <p>1PC</p>	<p>(Q) Butterfly Nut</p>  <p>4PCS</p>
<p>(D) Arm pillow</p>  <p>1PC</p>	<p>(I) Right armrest</p>  <p>1PC</p>	<p>(S) M8*50mm Bolt</p>  <p>4PCS</p>	

Parts List (BOX 3-MIDDLE)

A Seat frame  1PC	B Seat cushion  1PC	C Back Cushion  1PC	E Pillow  1PC
F Backrest  1PC	G Leg  4PC	L Gasket  4PCS	N Gasket  12PCS
O M8*60mm Bolt  4PCS	P M8*90mm Bolt  4PCS	R Alley Key  1PC	Q Butterfiy Nut  4PCS

ASSEMBLY STEPS

STEP 1: Assemble the Left armrest (H) to the Seat frame (A) with Washers (N) and Bolts (S).

BOX1-LEFT

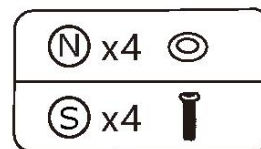
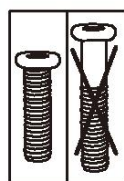
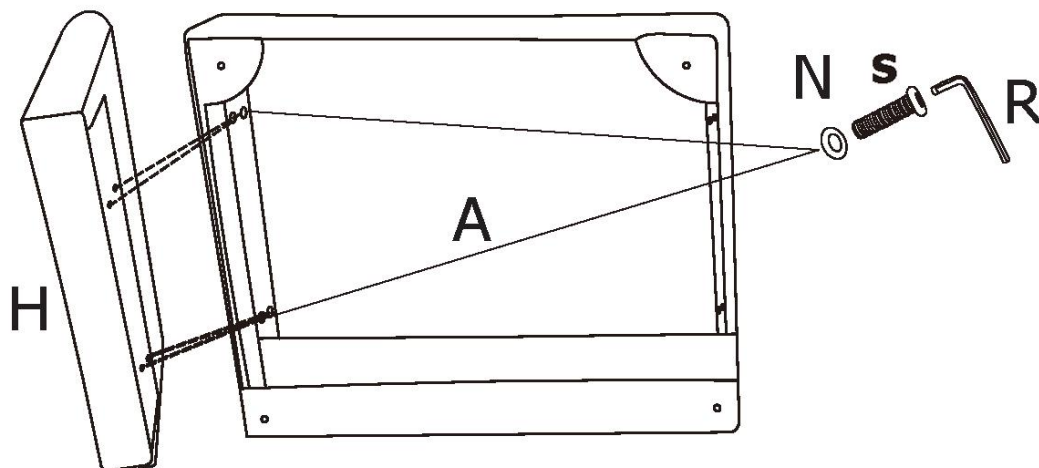

STEP 2: Assemble the Right armrest (I) to the Seat frame (A) with Washers (N) and Bolts (S).

BOX2-RIGHT

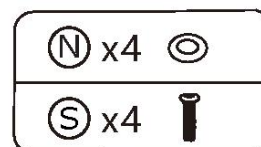
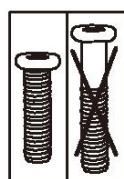
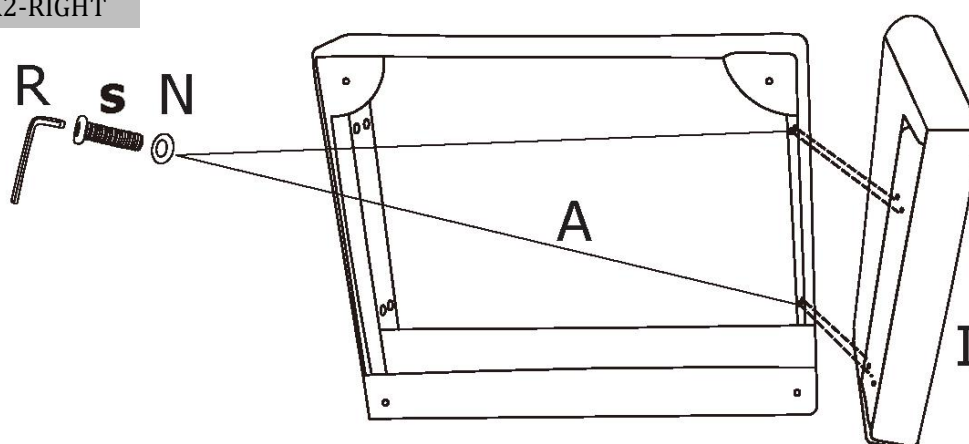

STEP 3: Assemble Seat frame (A) and Seat frame (A) with Butterfly nuts (Q) Washers (N) and Bolts (P).

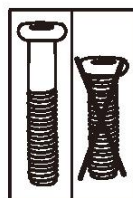
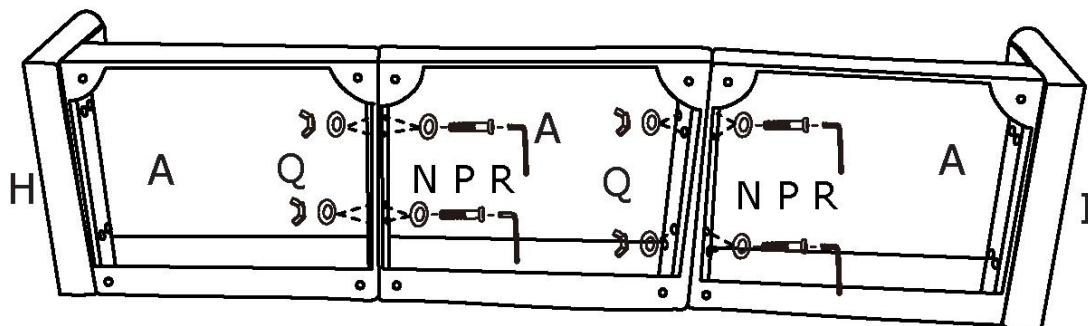

(N) x 16	(C)
(P) x 8	(I)
(Q) x 8	(G)

STEP 4: Assemble the Legs (G) on the sofa with Gaskets (L).

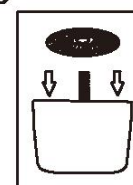
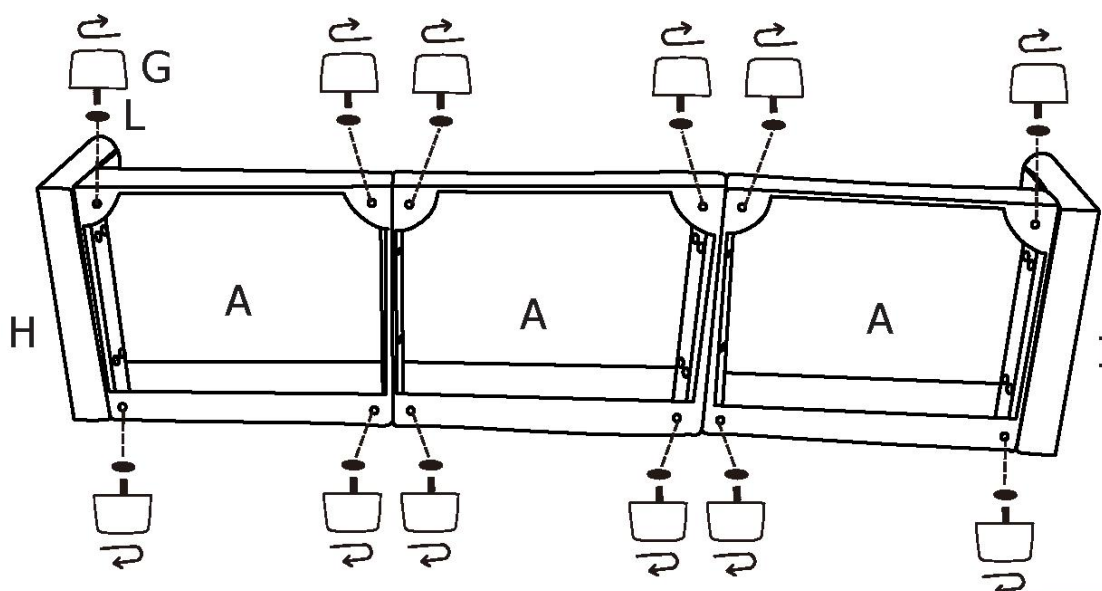

STEP 5: Insert the Backrest (F) into the designated holes, using Washer (N) and Bolts (O) to 70% tightness, and then tighten the all Bolts on the seat.

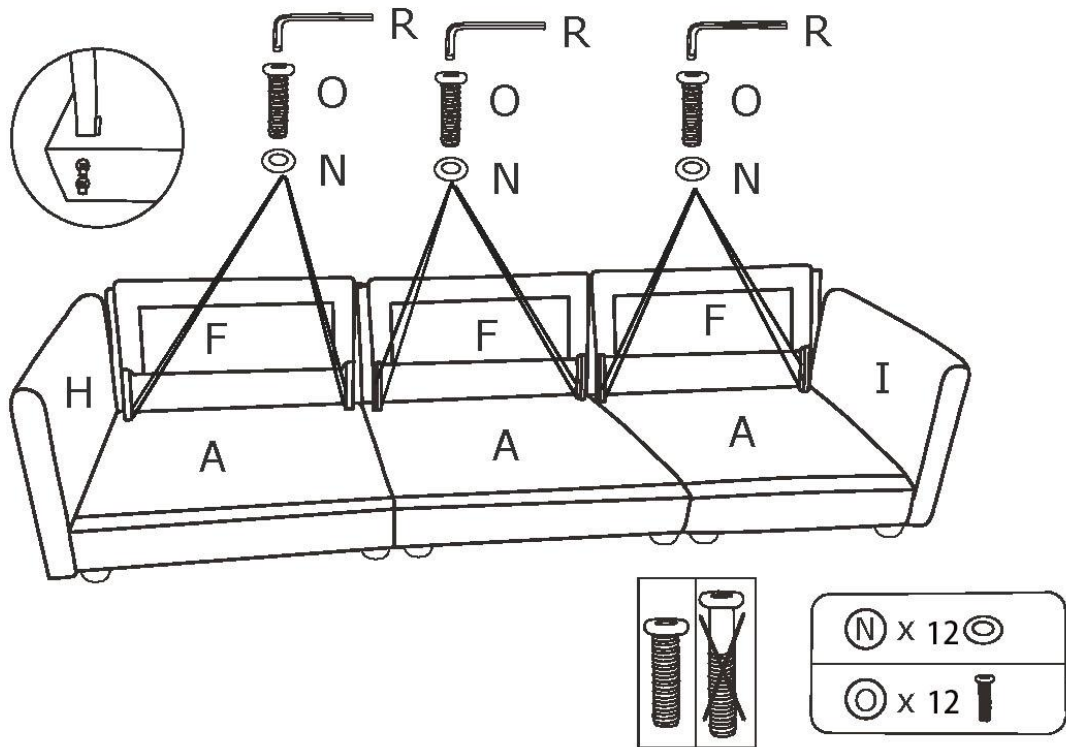

STEP 6: The cushion is packaged by vacuum compression. After cutting the package, it rebounds quickly within 4 hours. If the fabric has wrinkles, it will basically disappear after standing for 72 hours

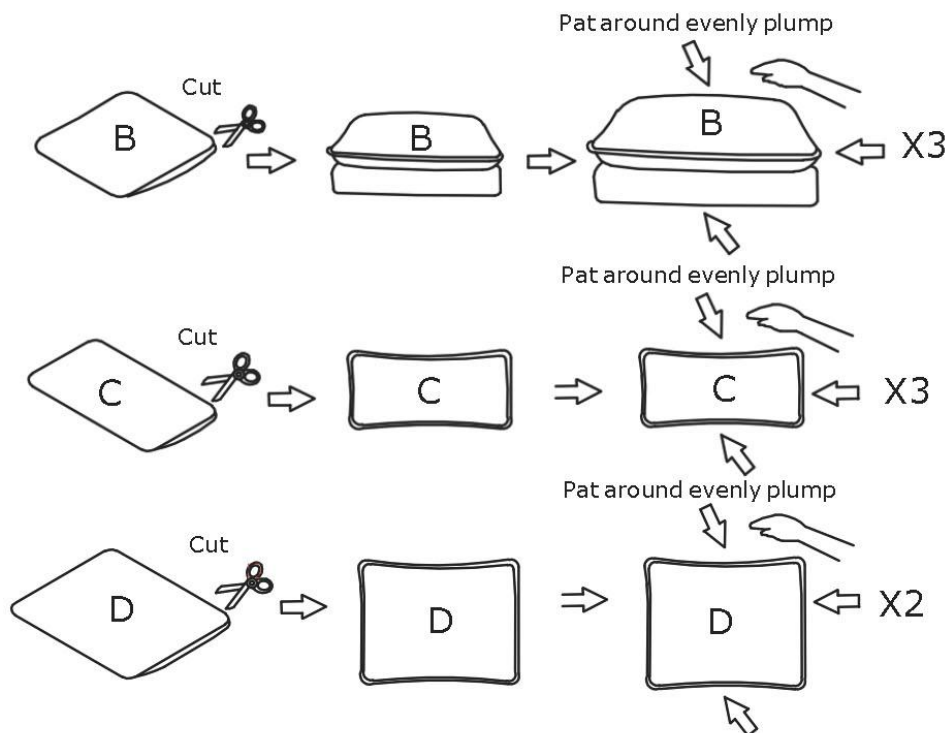

STEP 7: Place Seat cushions (B) and back cushions (C), and make sure it's will fitted.

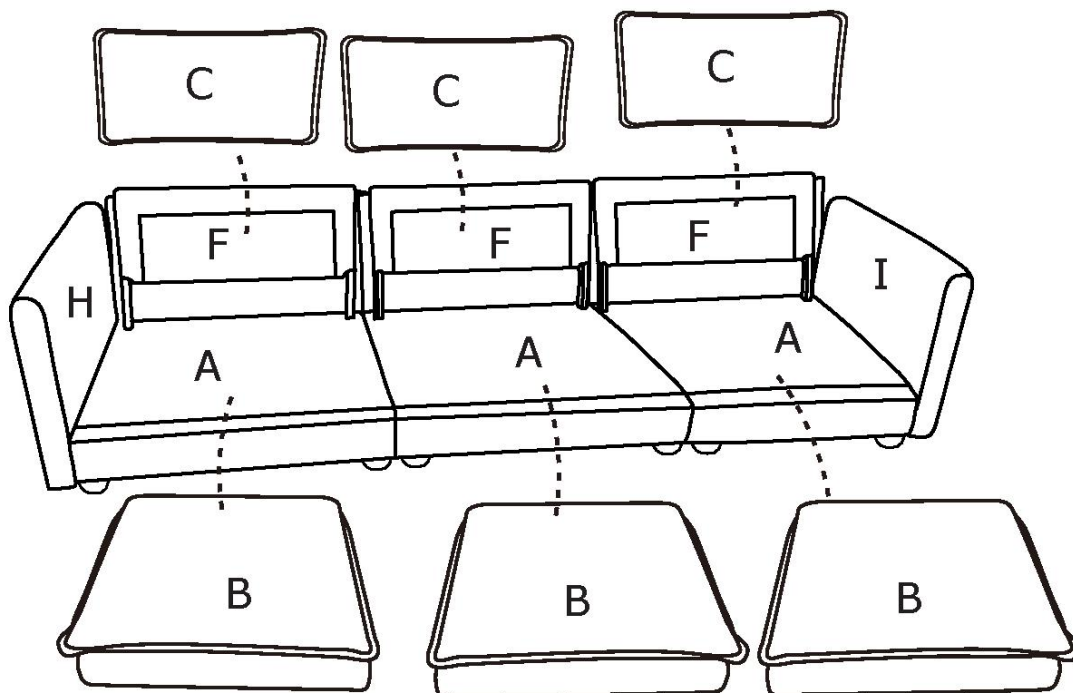



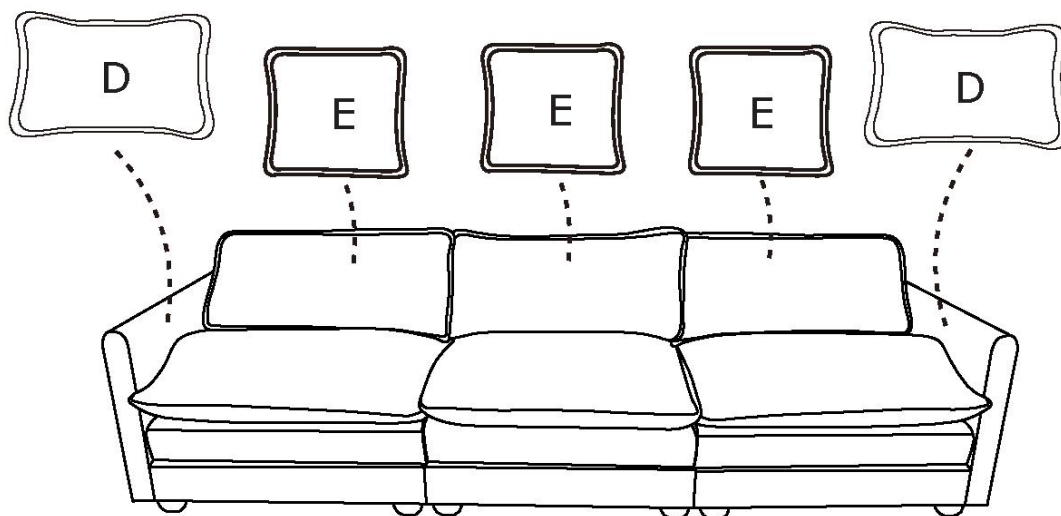







STEP 8: Place Pillows (E) and Pillows (D) on sofa and make sure it's will fitted.



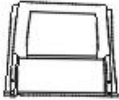



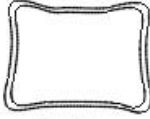

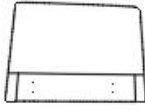





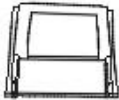

IF YOU BUY 4 SEATER SOFA
please follow below assembly instruction

Parts incidued





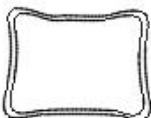
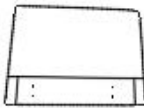



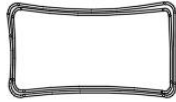
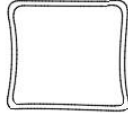
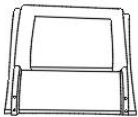

Parts List (BOX 1-LEFT)

<p>A Seat frame</p>  <p>1PC</p>	<p>B Seat cushion</p>  <p>1PC</p>	<p>C Back Cushion</p>  <p>1PC</p>	<p>E Pillow</p>  <p>1PC</p>
<p>F Backrest</p>  <p>1PC</p>	<p>G Leg</p>  <p>4PC</p>	<p>L Gasket</p>  <p>4PCS</p>	<p>N Gasket</p>  <p>8 PCS</p>
<p>O M8*60mm Bolt</p>  <p>4PCS</p>	<p>D Arm pillow</p>  <p>1PC</p>	<p>S M8*50mm Bolt</p>  <p>4PCS</p>	<p>H Left armrest</p>  <p>1PC</p>

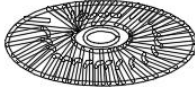







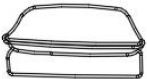

Parts List (BOX 2-RIGHT)

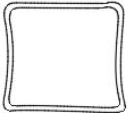
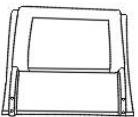
<p>A Seat frame</p>  <p>1PC</p>	<p>B Seat cushion</p>  <p>1PC</p>	<p>C Back Cushion</p>  <p>1PC</p>	<p>E Pillow</p>  <p>1PC</p>
<p>F Backrest</p>  <p>1PC</p>	<p>G Leg</p>  <p>4PC</p>	<p>L Gasket</p>  <p>4PCS</p>	<p>N Gasket</p>  <p>16PCS</p>
<p>O M8*60mm Bolt</p>  <p>4PCS</p>	<p>P M8*90mm Bolt</p>  <p>4PCS</p>	<p>R Alley Key</p>  <p>1PC</p>	<p>Q Butterfiy Nut</p>  <p>4PCS</p>
<p>D Arm pillow</p>  <p>1PC</p>	<p>I Right armrest</p>  <p>1PC</p>	<p>S M8*50mm Bolt</p>  <p>4PCS</p>	

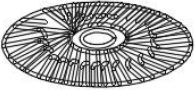
Parts List (BOX 3-MIDDLE)

A Seat frame  1PC	B Seat cushion  1PC	C Back Cushion  1PC	E Pillow  1PC
F Backrest  1PC	G Leg  4PC	L Gasket  4PCS	N Gasket  12PCS
O M8*60mm Bolt  4PCS	P M8*90mm Bolt  4PCS	R Alley Key  1PC	Q Butterfiy Nut  4PCS

Parts List (BOX 4-MIDDLE)

A Seat frame  1PC	B Seat cushion  1PC	C Back Cushion  1PC	E Pillow  1PC
F Backrest  1PC	G Leg  4PC	L Gasket  4PCS	N Gasket  12PCS
O M8*60mm Bolt  4PCS	P M8*90mm Bolt  4PCS	R Alley Key  1PC	Q Butterfiy Nut  4PCS

ASSEMBLY STEPS

STEP 1: Assemble the Left armrest (H) to the Seat frame (A) with Washers (N) and Bolts (S).

B0X1-LEFT

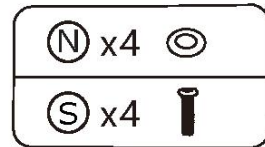
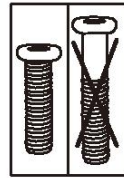
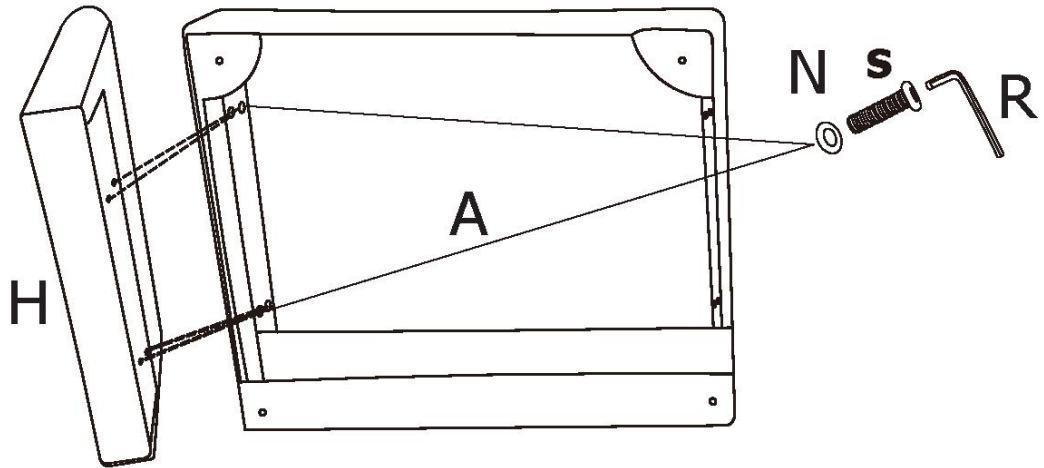

STEP 2: Assemble the Right armrest (I) to the Seat frame (A) with Washers (N) and Bolts (S).

B0X2-RIGHT

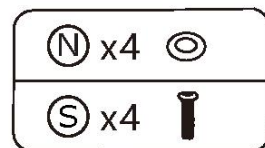
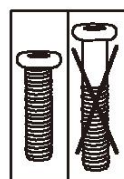
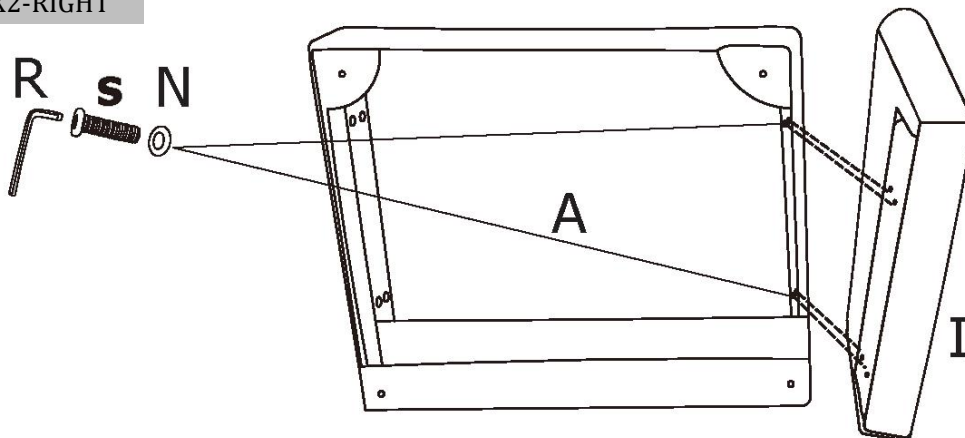

STEP 3: Assemble Seat frame (A) and Seat frame (A) with Butterfly nuts (Q) Washers (N) and Bolts (P).

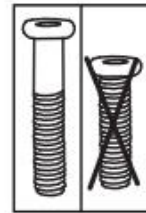
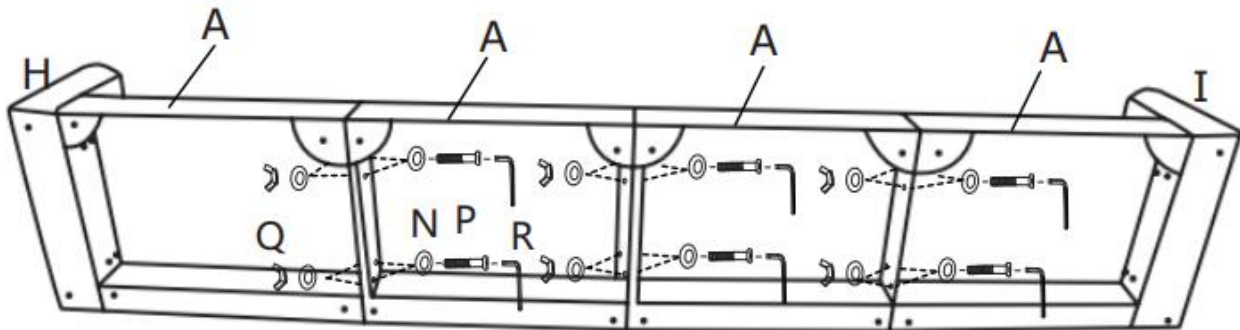

$\textcircled{N} \times 24$	\textcircled{Q}
$\textcircled{P} \times 12$	\textcircled{R}
$\textcircled{Q} \times 12$	\textcircled{R}

STEP 4: Assemble the Legs (G) on the sofa with Gaskets (L).

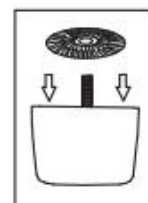
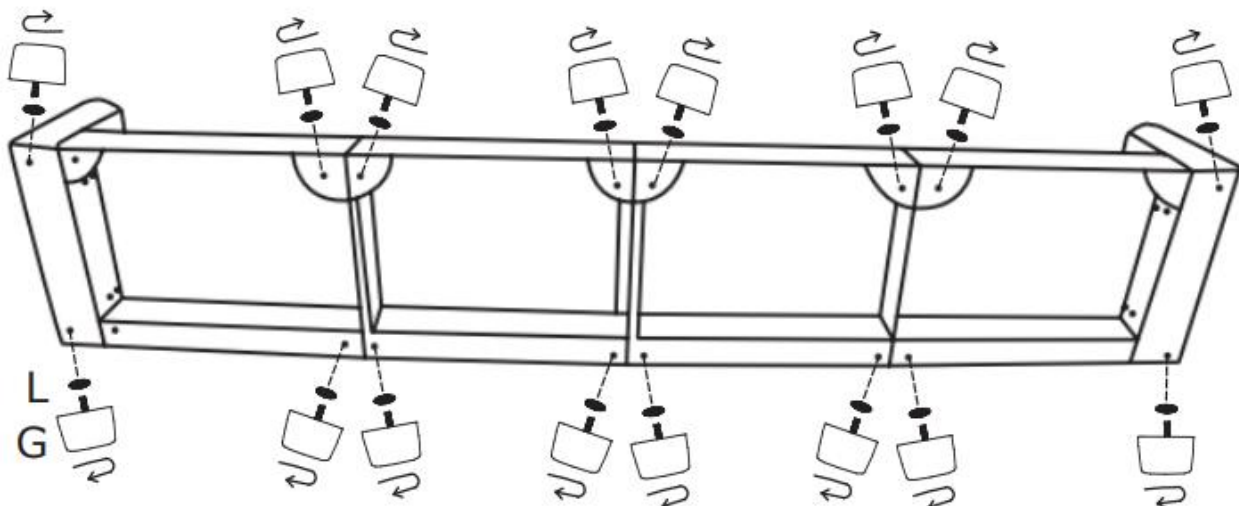

STEP 5: Insert the Backrest (F) into the designated holes, using Washer (N) and Bolts (O) to 70% tightness, and then tighten the all Bolts on the seat.

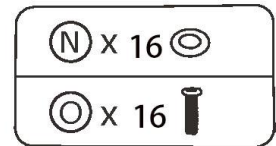
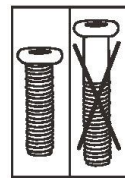
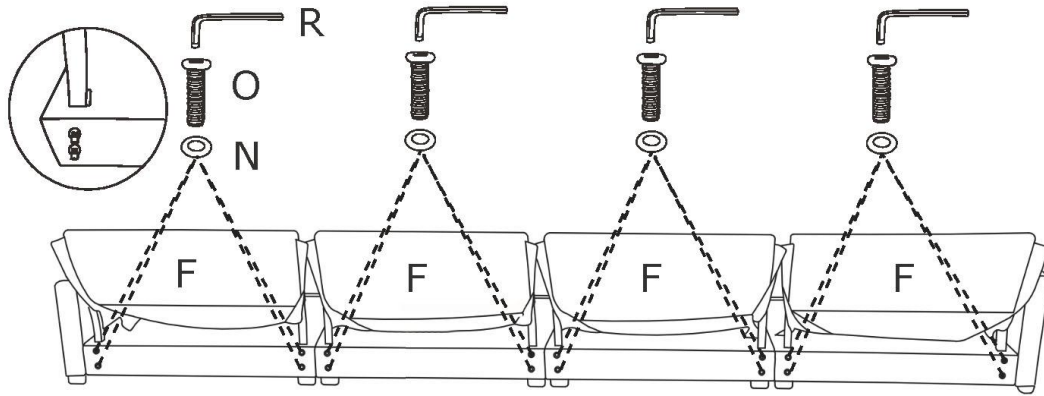

STEP 6: The cushion is packaged by vacuum compression. After cutting the package, it rebounds quickly within 4 hours. If the fabric has wrinkles, it will basically disappear after standing for 72 hours

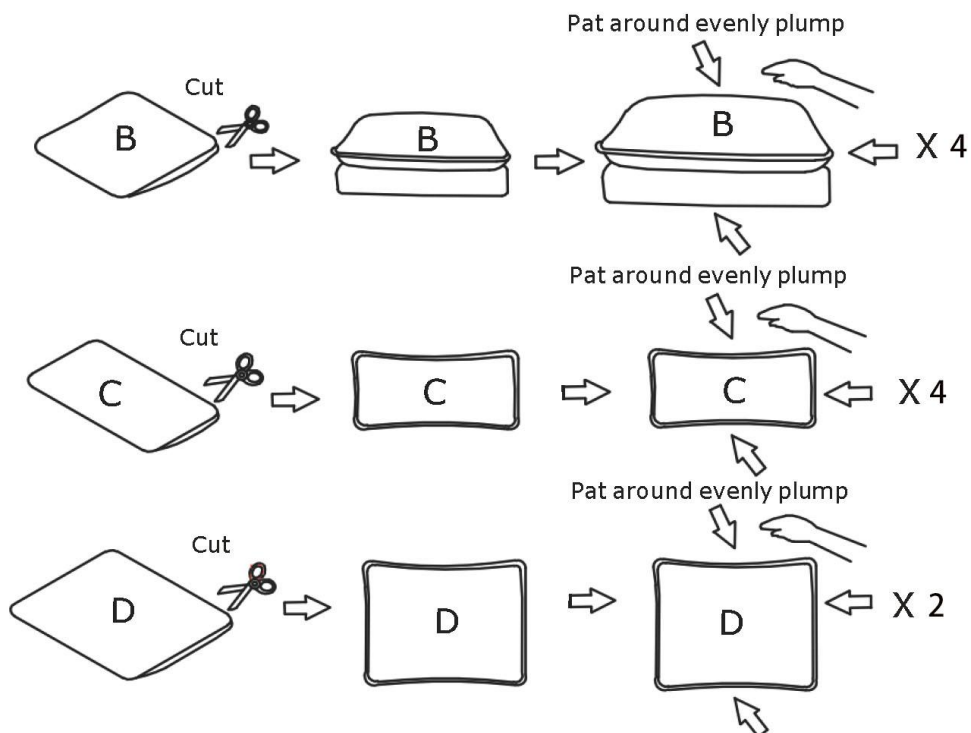

STEP 7: Place Seat cushions (B) and back cushions (C), and make sure it's will fitted.

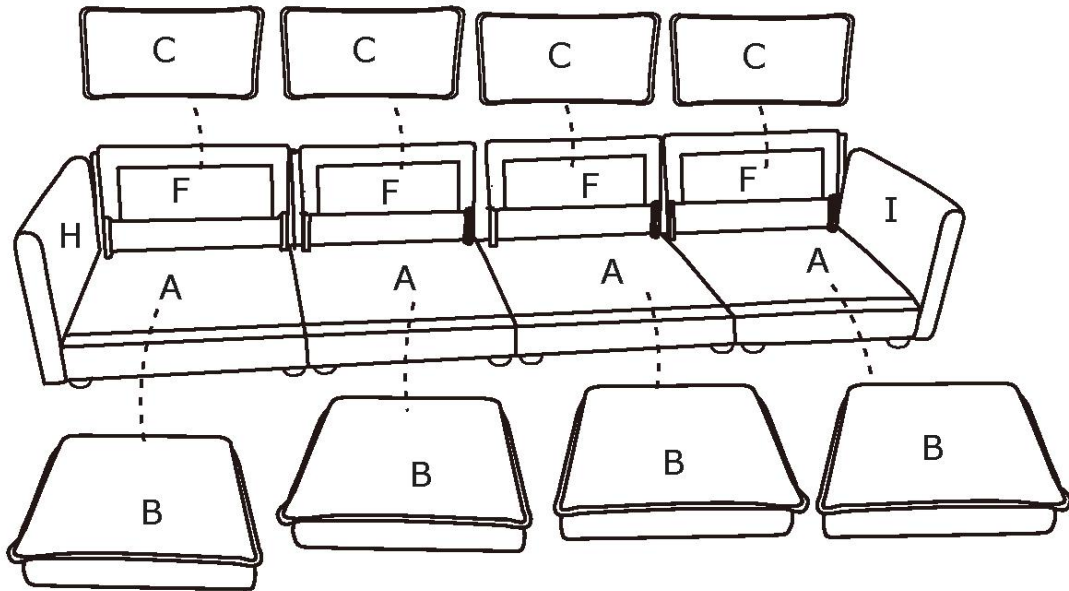



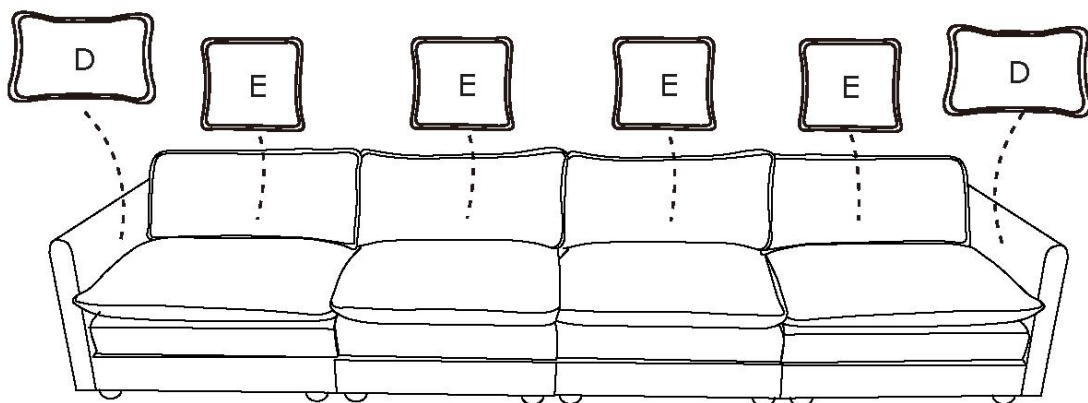

STEP 8: Place Pillows (E) and Pillows (D) on sofa and make sure it's will fitted.



IF YOU BUY A OTTOMAN
please follow below assembly instruction

Parts incidued

Parts List (BOX 1)

<p>A Seat frame</p>  <p>1PC</p>	<p>B Seat cushion</p>  <p>1PC</p>	<p>G Leg</p>  <p>4PC</p>	<p>L Gasket</p>  <p>4PCS</p>
---	---	--	--

STER 1: Assemble the Legs(G) on the sofa wyth Gaskets(L).

