

Installation Instruction

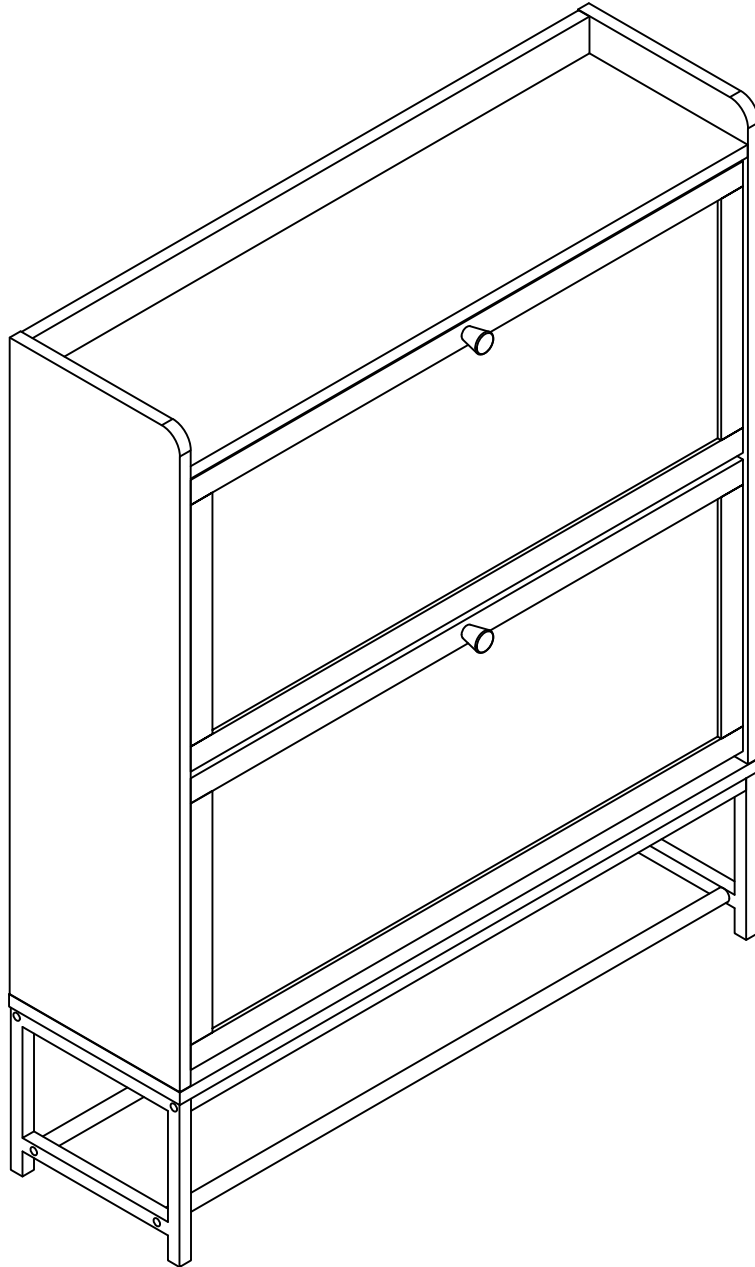

Assembling

Estimated time for assembly



45 : 00

What you need

- Use the packaging carton as a working surface to prevent product damage during assembly
- Phillips head screwdriver

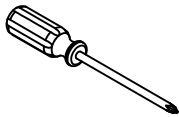

Weight Limitation

 **100** | **35**
lbs table top lbs per



What' included

Code Description	Qty
A Cam Bolt M6X35MM	10
B Cam Lock 15X12MM	10
C Wooden Dowel M7.8X30MM	10
D Screw M4X40MM	9
E The screw M3.5X16MM	26
F Inner Shaft	4
G Stopper	4
H External Shaft	4
I The screw M6X35MM	8
J Metal connector	2
K Cam Bolt M4X18MM	2
L Left Plastic Holder	2
M Metal shake handhandle	2
N Screw M4X10MM	4
O The screw M6X25MM	8
P Anchor	2
Q Wrench M4X55MM	1
R Right Plastic Holder	2

The Hardwares

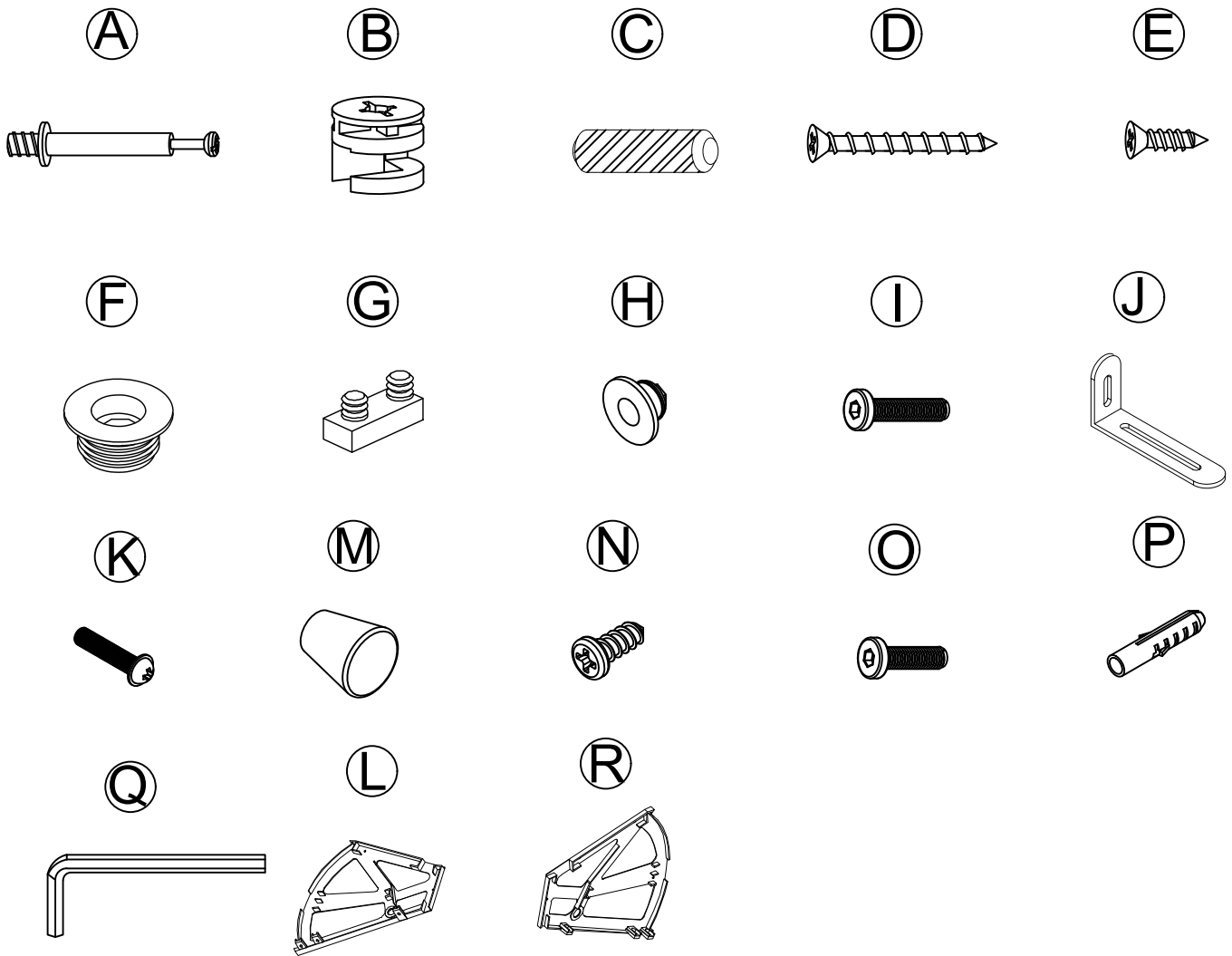

IMPORTANT:

1. Do not tighten bolts / screws completely until all bolts / screws are lined up and inserted into holes.
2. Do not over tighten screws and bolts to avoid stripping
3. Please use hand tools to assemble this product. Do not use power tools.

Included Accessories

Code	Description	Qty
1	Cabinet Top	1
2	Bottom Panel	1
3	Left Side Panel	1
4	Right Side Panel	1
5	Back stiffener	1
6	Door	2
7	Inner lamella	2
8	Large inner plate	4
9	Back top plate	1
10	Left and right metal legs	2
11	Upper metal connecting rod	2
12	Lower metal connecting rod	2

The Accessoriess

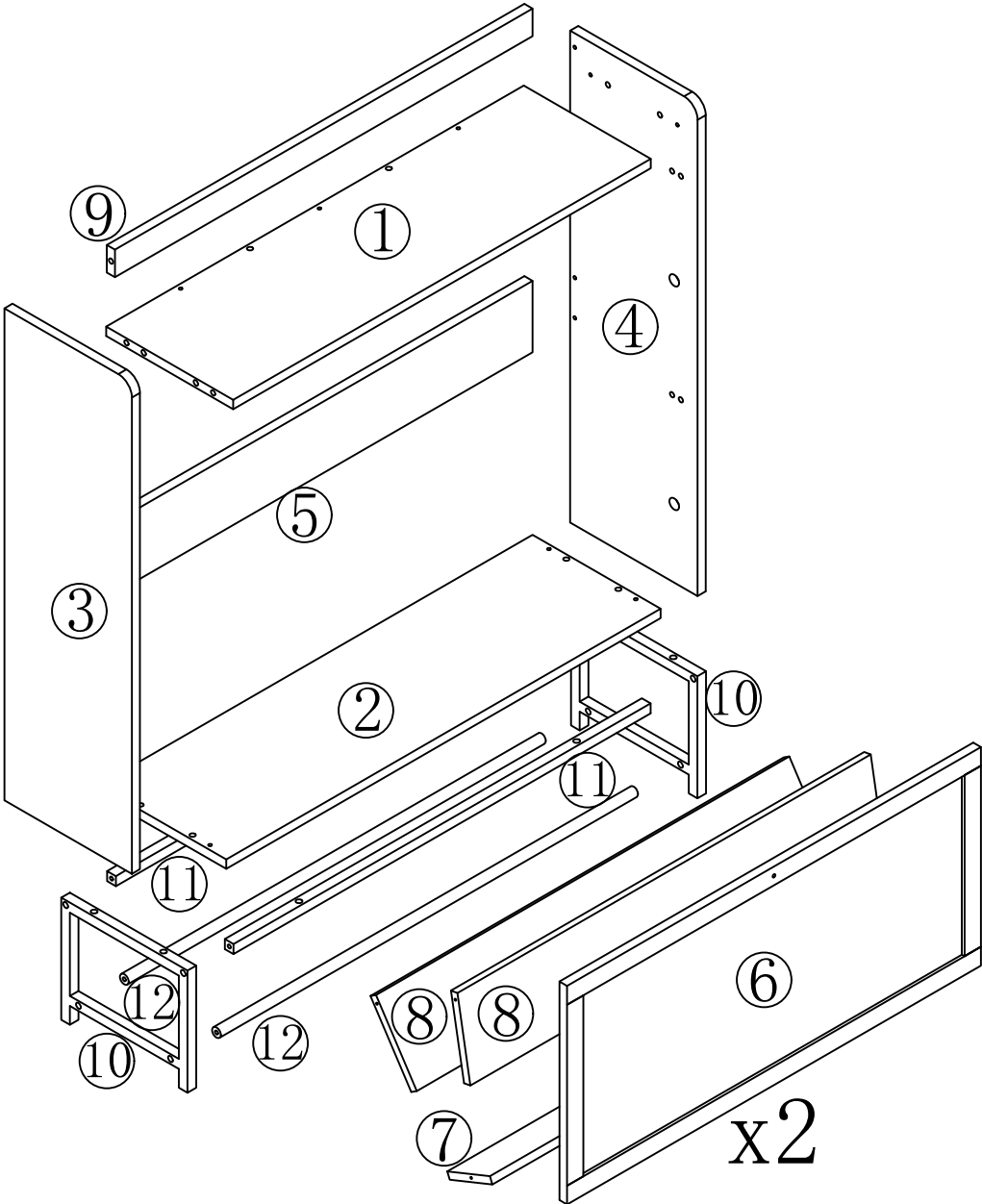

Step 1

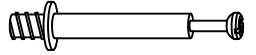
A	×10
	

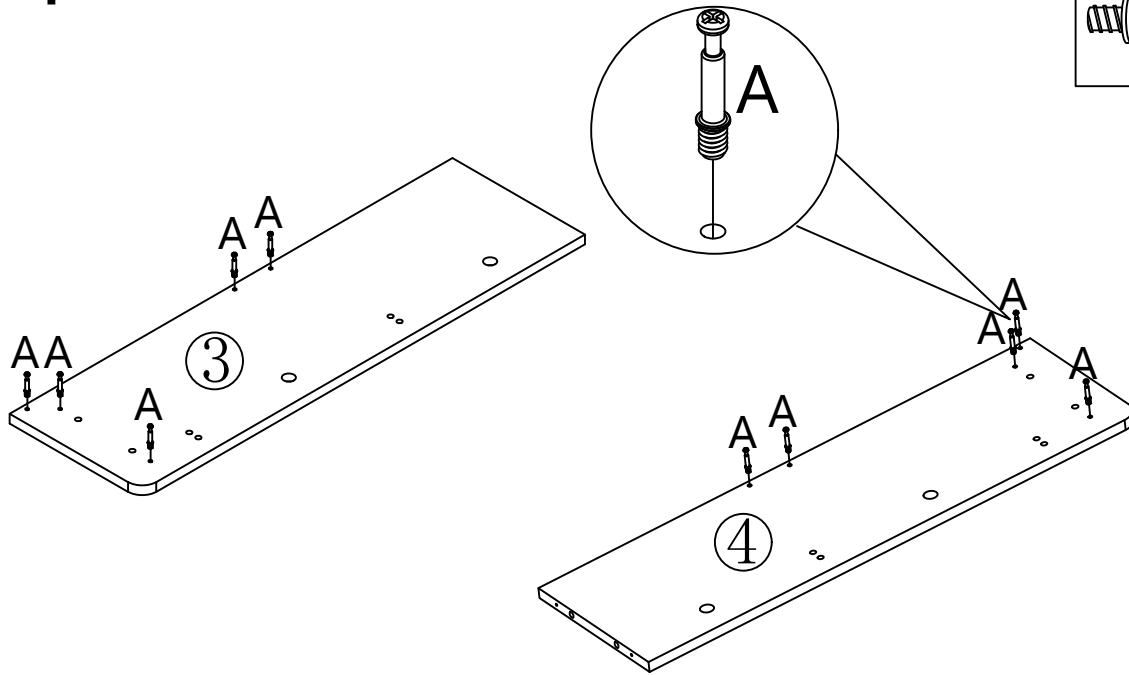

Step 2

F	×4
	

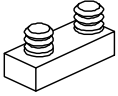
G	×4
	

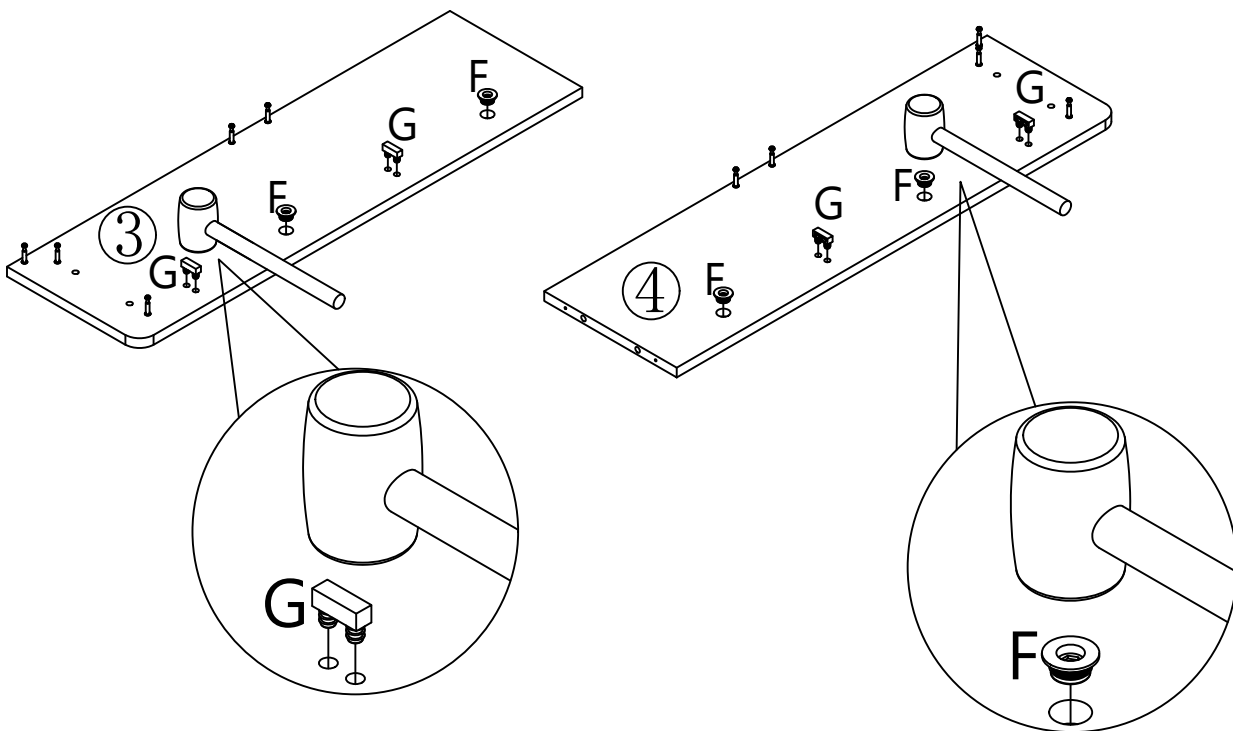

Step 3

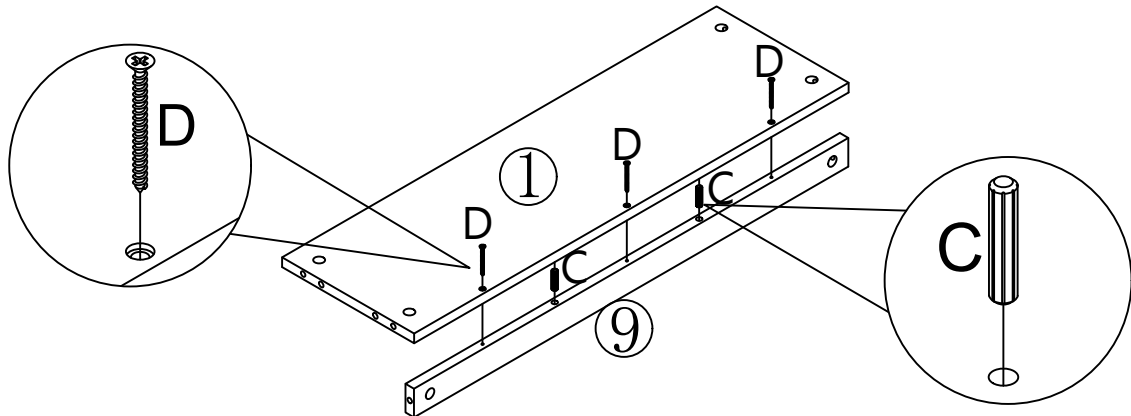
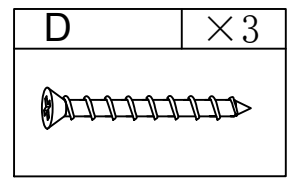
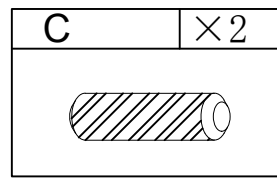

Step 4

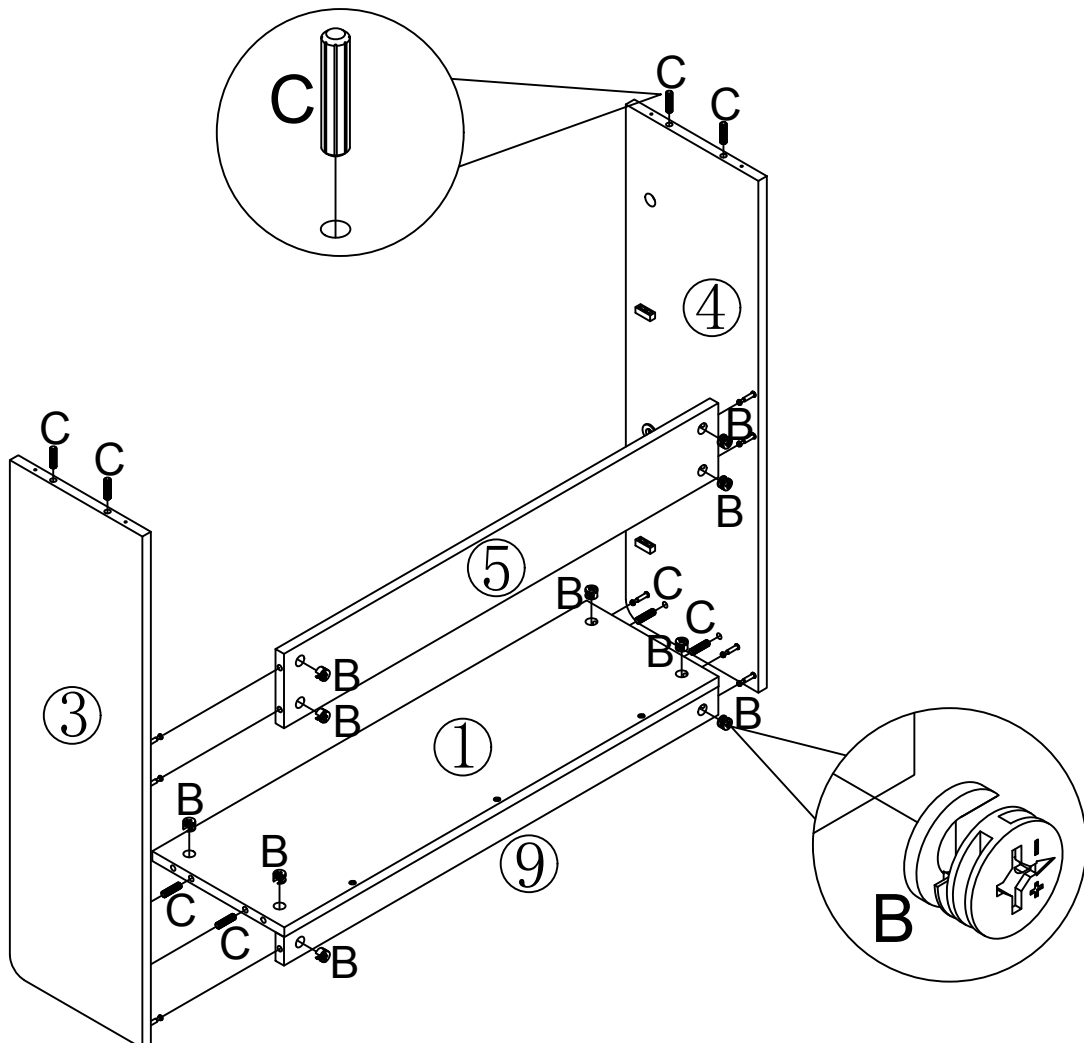
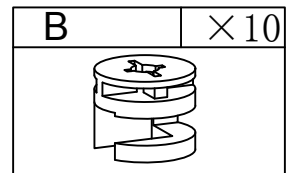
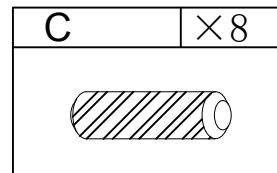

Step 5

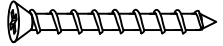
D	×4
	

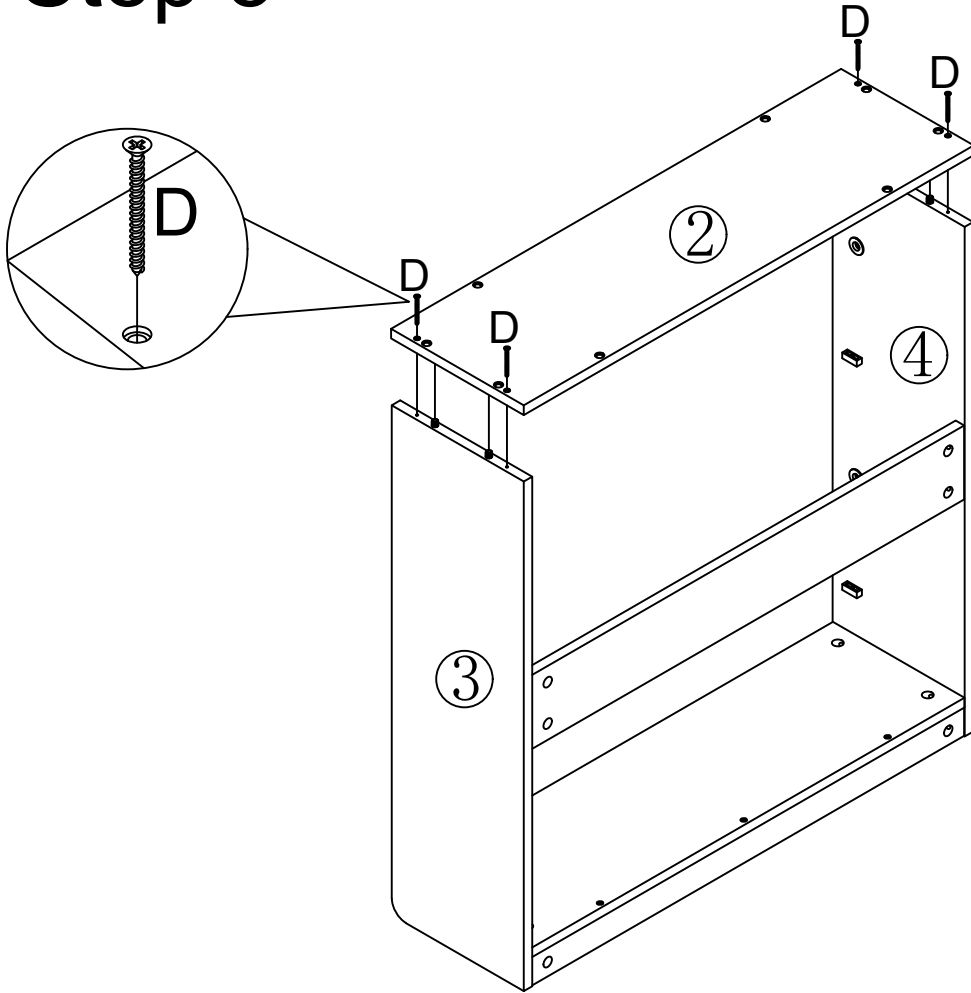

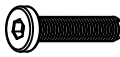
I	×8
	

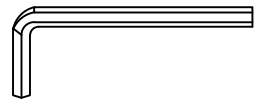
Q	×1
	

Step 6

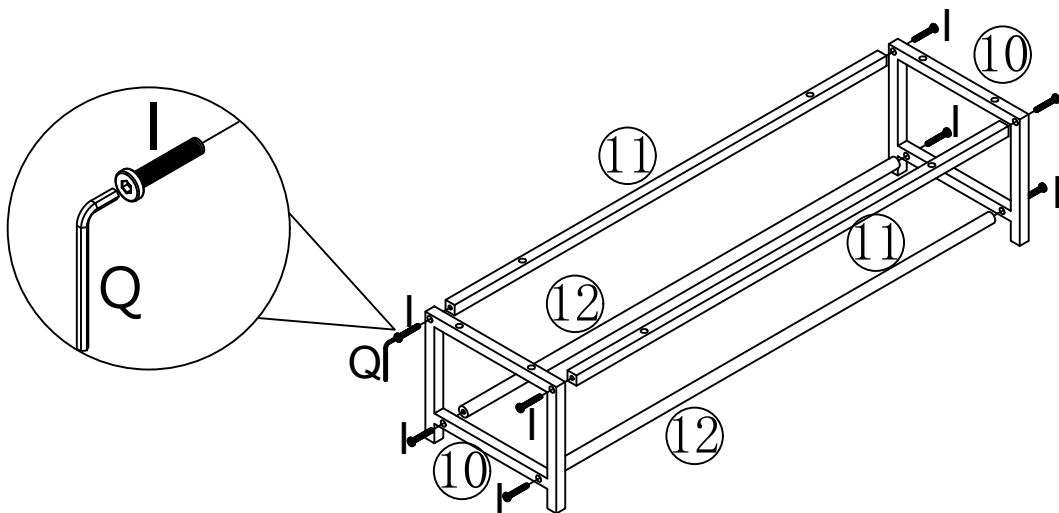

Step 7

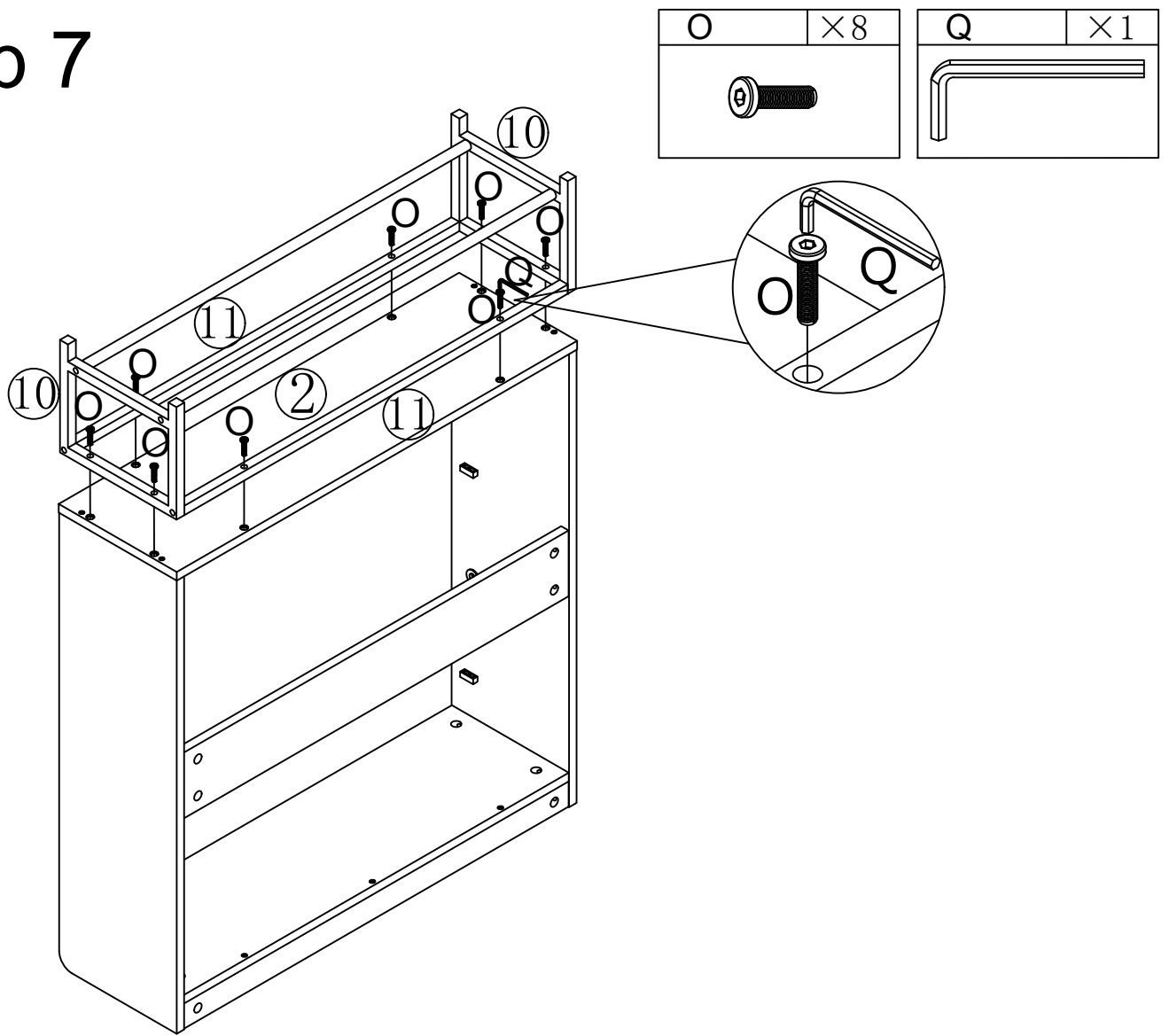

Step 8

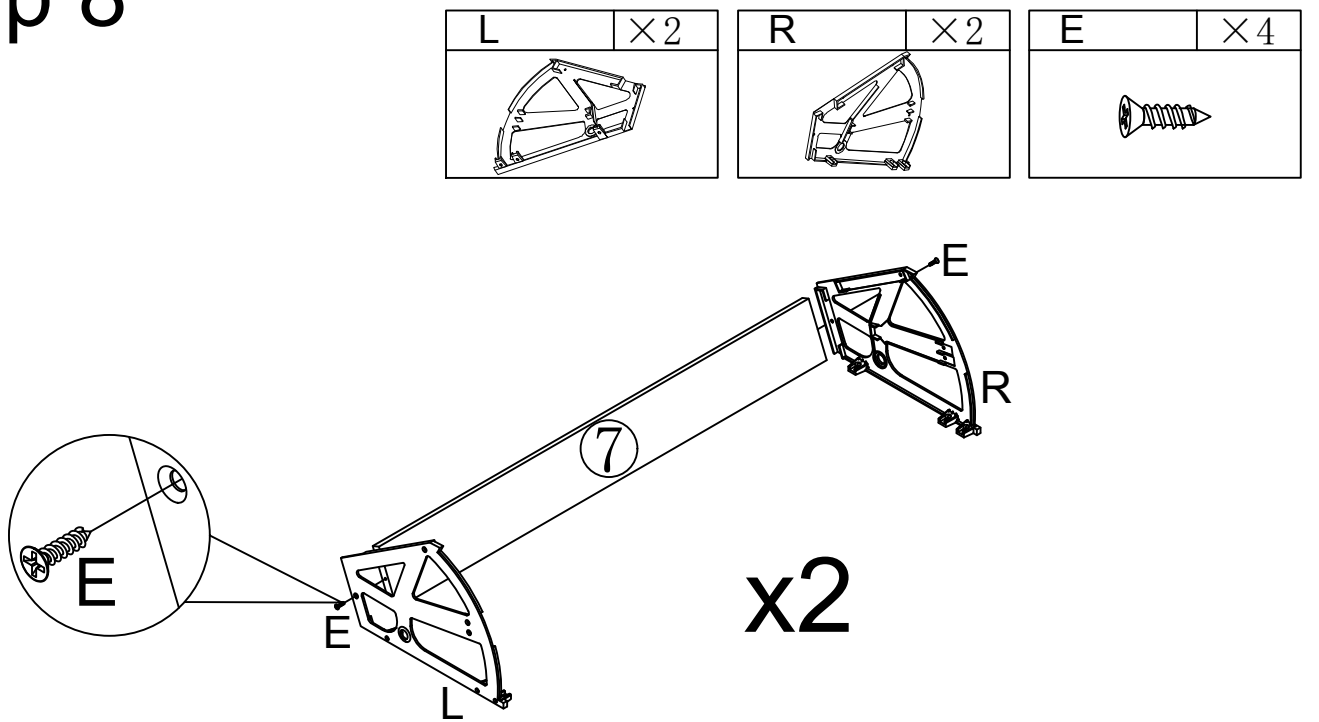

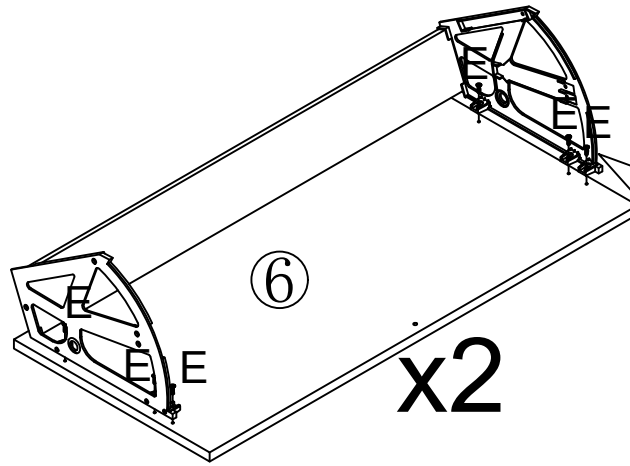

Step 9

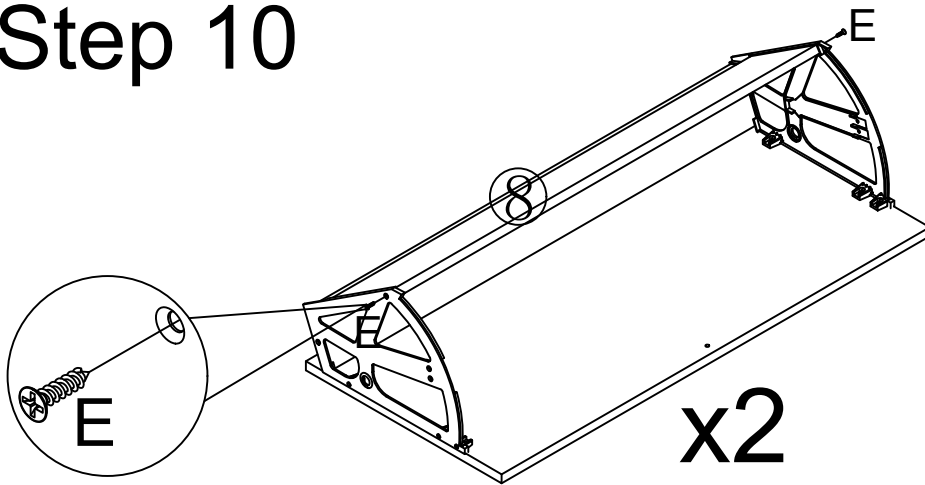

E	×12
	

Step 10



E	×4
	

Step 11

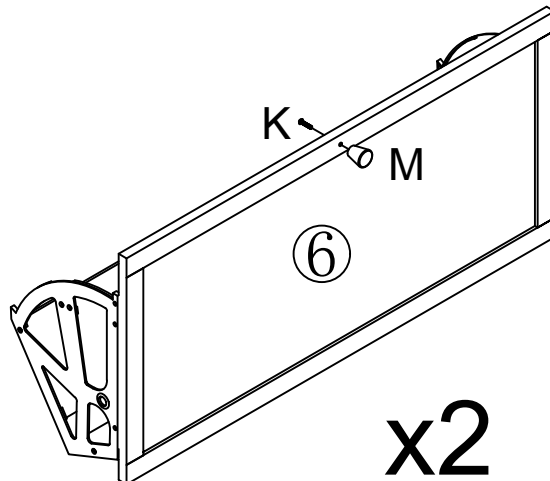

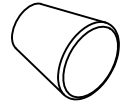

K	×2
	

M	×2
	

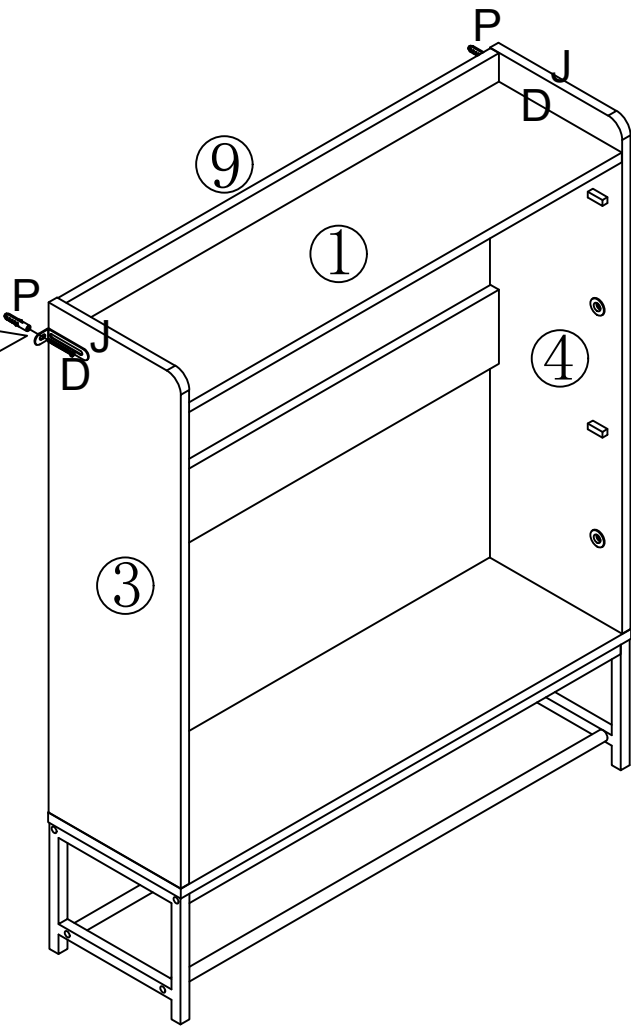
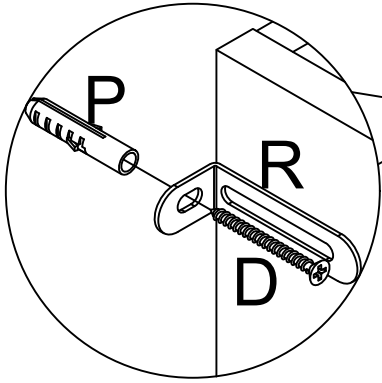
Step 12

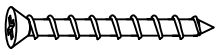

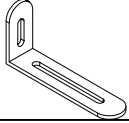
D	×2
	
P	×2
	
J	×2
	

Step 13

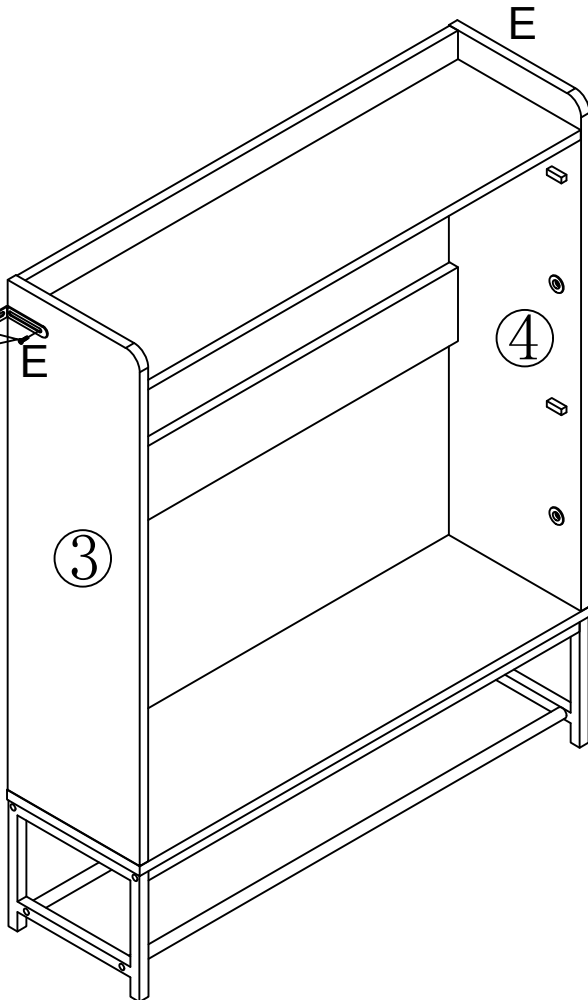
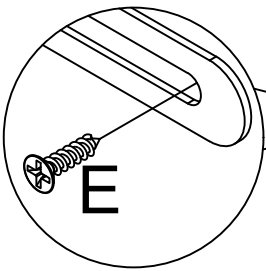

E	×2
	

Step 14

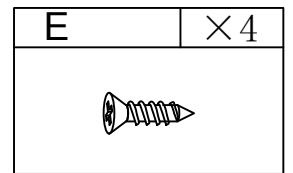
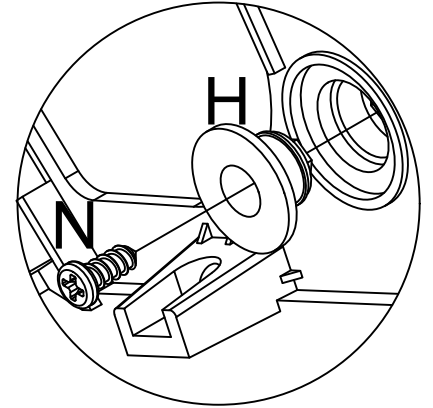
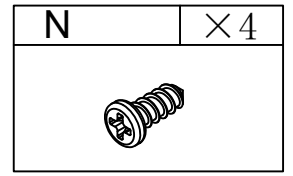
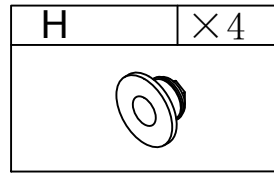
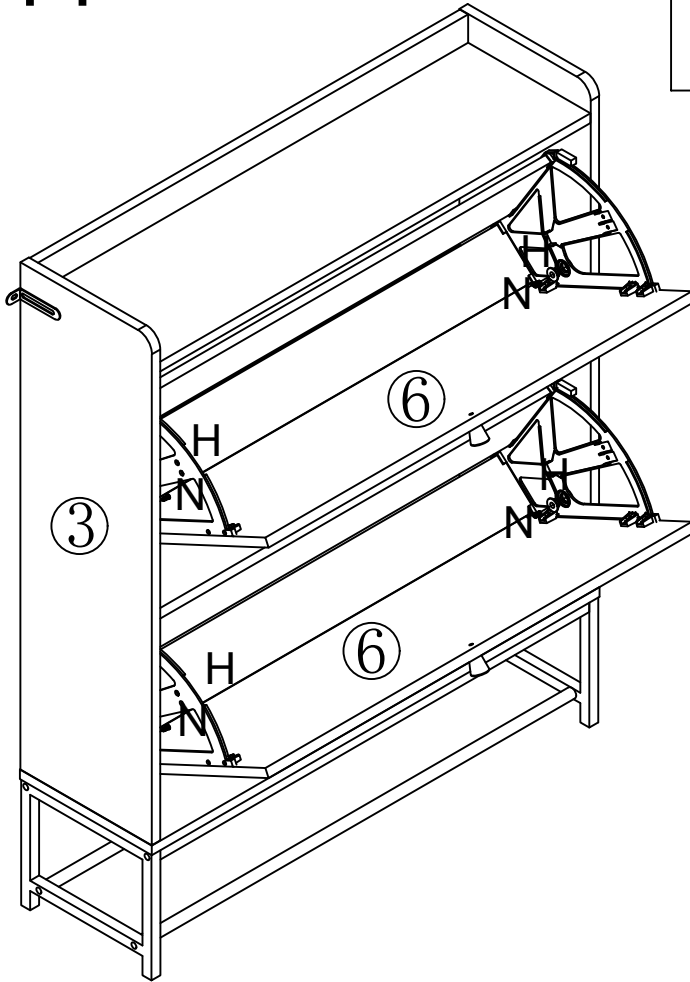

Step 15

