

# WARNING!

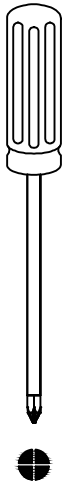

MAXIMUM LOAD  
220 lb/100kg

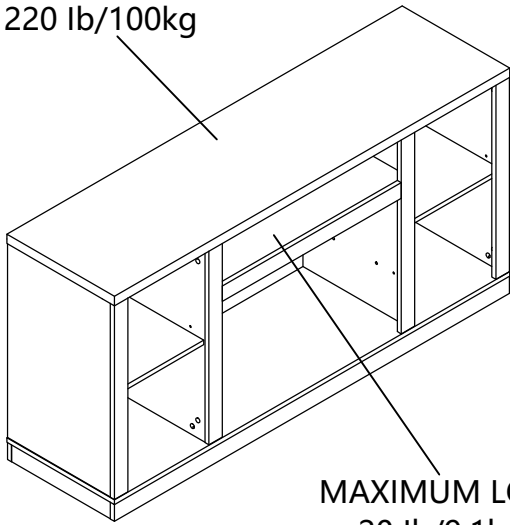

MAXIMUM LOAD  
20 lb/9.1kg



Estimated Time for Assembly

**45 mins**

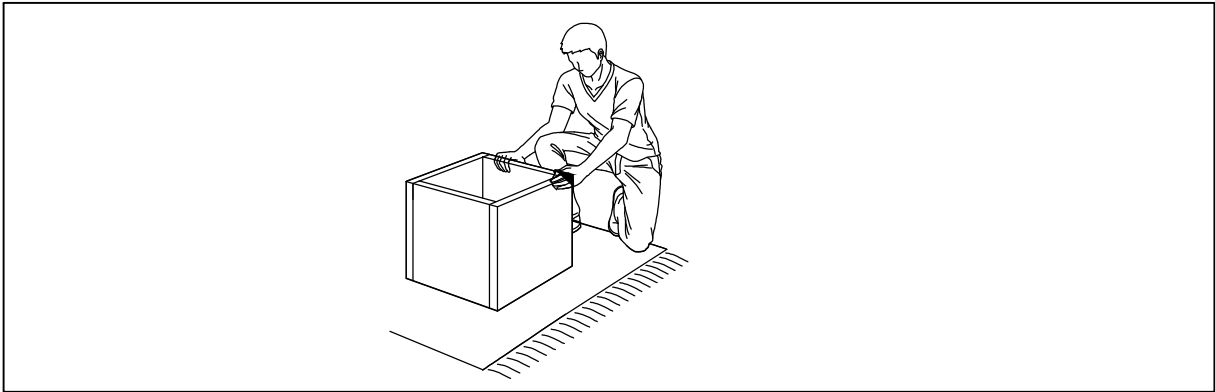

Assemble the furniture on empty carton, carpet, or rug to prevent scratches or damage.

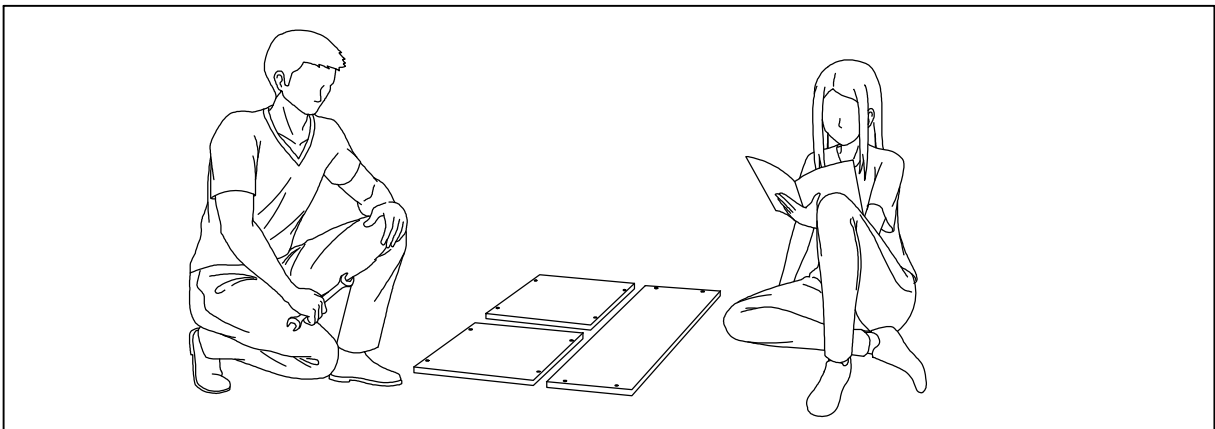

This furniture requires 2 people to assembly.  
Make sure no parts are missing or damaged before assembly.

Not actual size

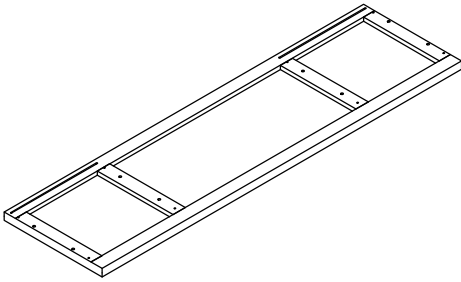

① X1

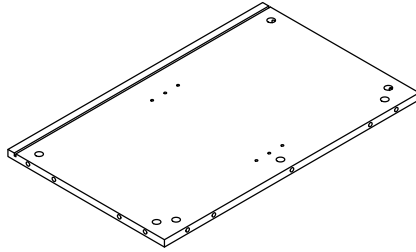

② X2

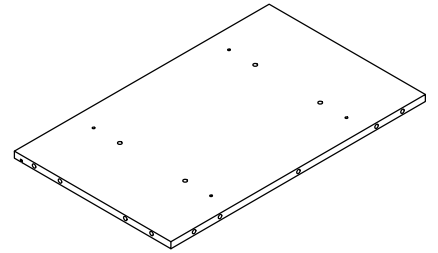

③ X2

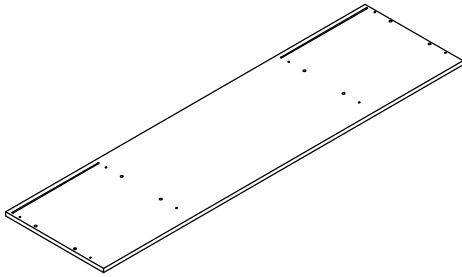

④ X1

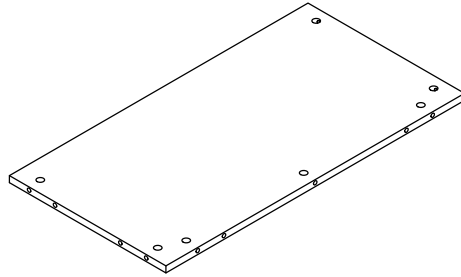

⑤ X1

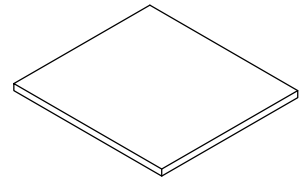

⑥ X2

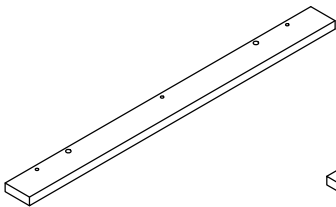

⑦ X2

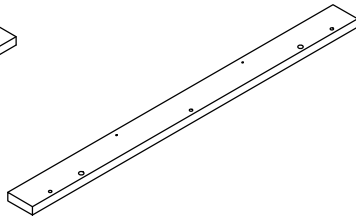

⑧ X1

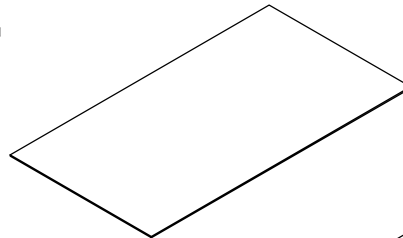

⑨ X2

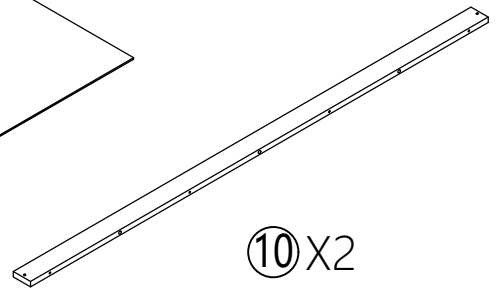

⑩ X2

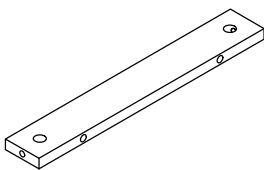

⑪ X2

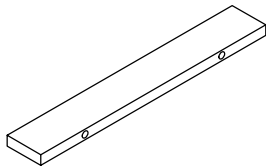

⑫ X1

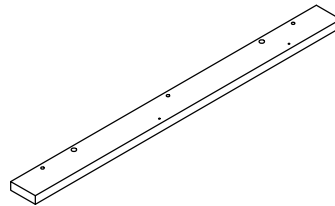



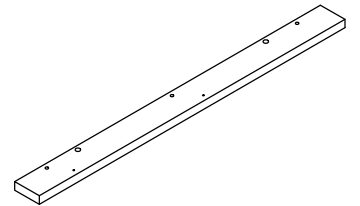



⑬ X1

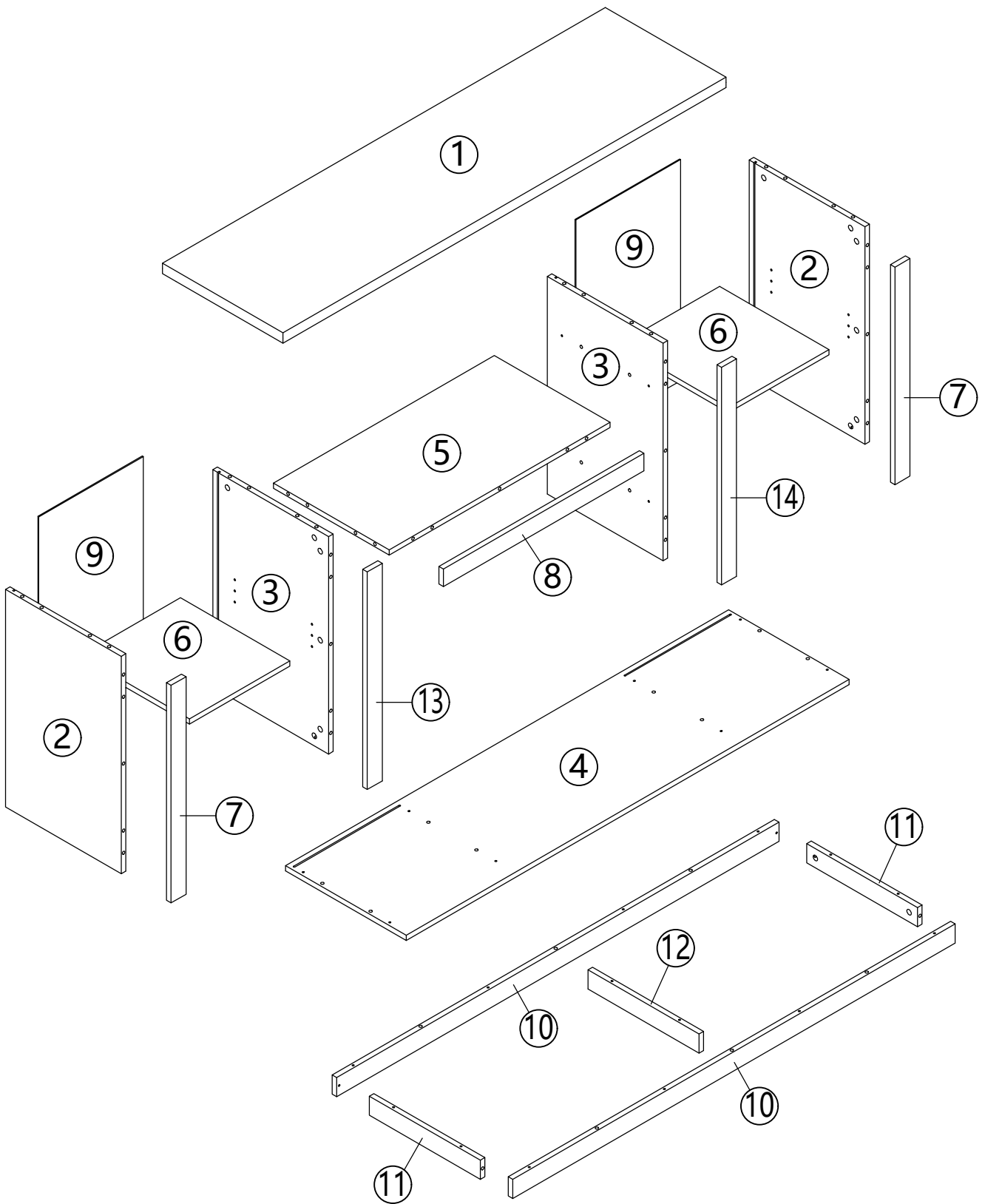

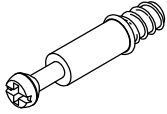
⑭ X1

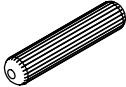
# PACKAGE CONTENT

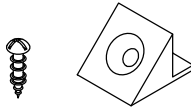

<b>A</b>	X39+3	<b>B</b>	X39+3	<b>C</b>	X36+3	<b>D</b>	X14+1
							
$\phi 6*35$		$\phi 15*11.5$		$\phi 8*30$		$\phi 4*50$	
<b>E</b>	X8	<b>F</b>	X12+1	<b>G</b>	X1		
							
$\phi 5*16$		$\phi 3*14$		$90*30*5$			

## Cam Lock Fastening System

Insert the cam bolt into the hole first, then insert the cam lock and lock it.

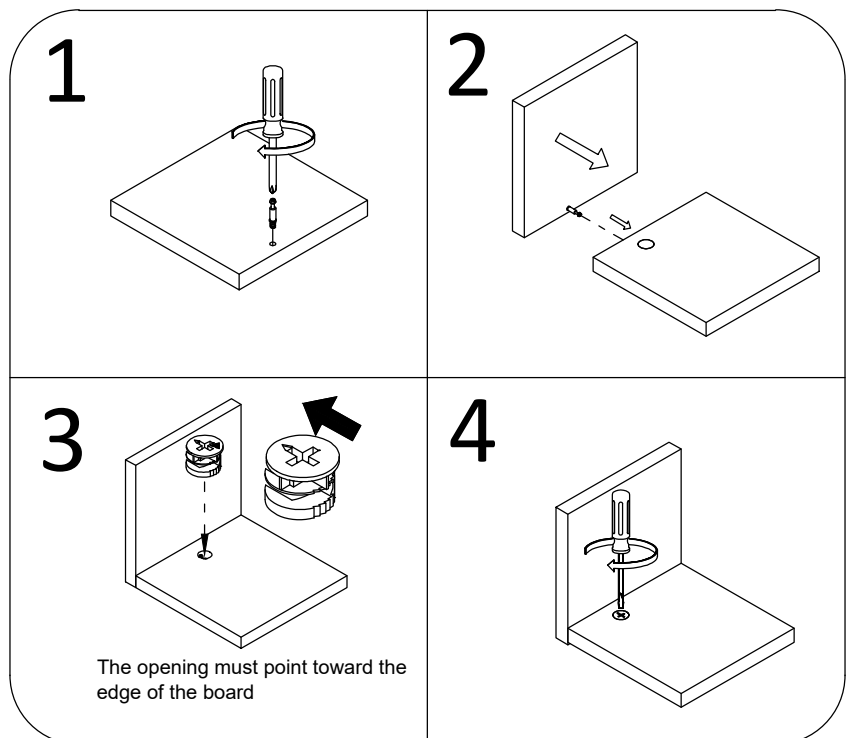

# STEP 1

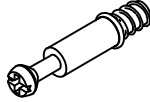
(A)	X4
	
ø6*35	

(B)	X4
	
ø15*11.5	

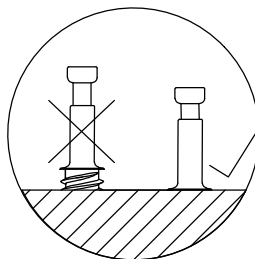
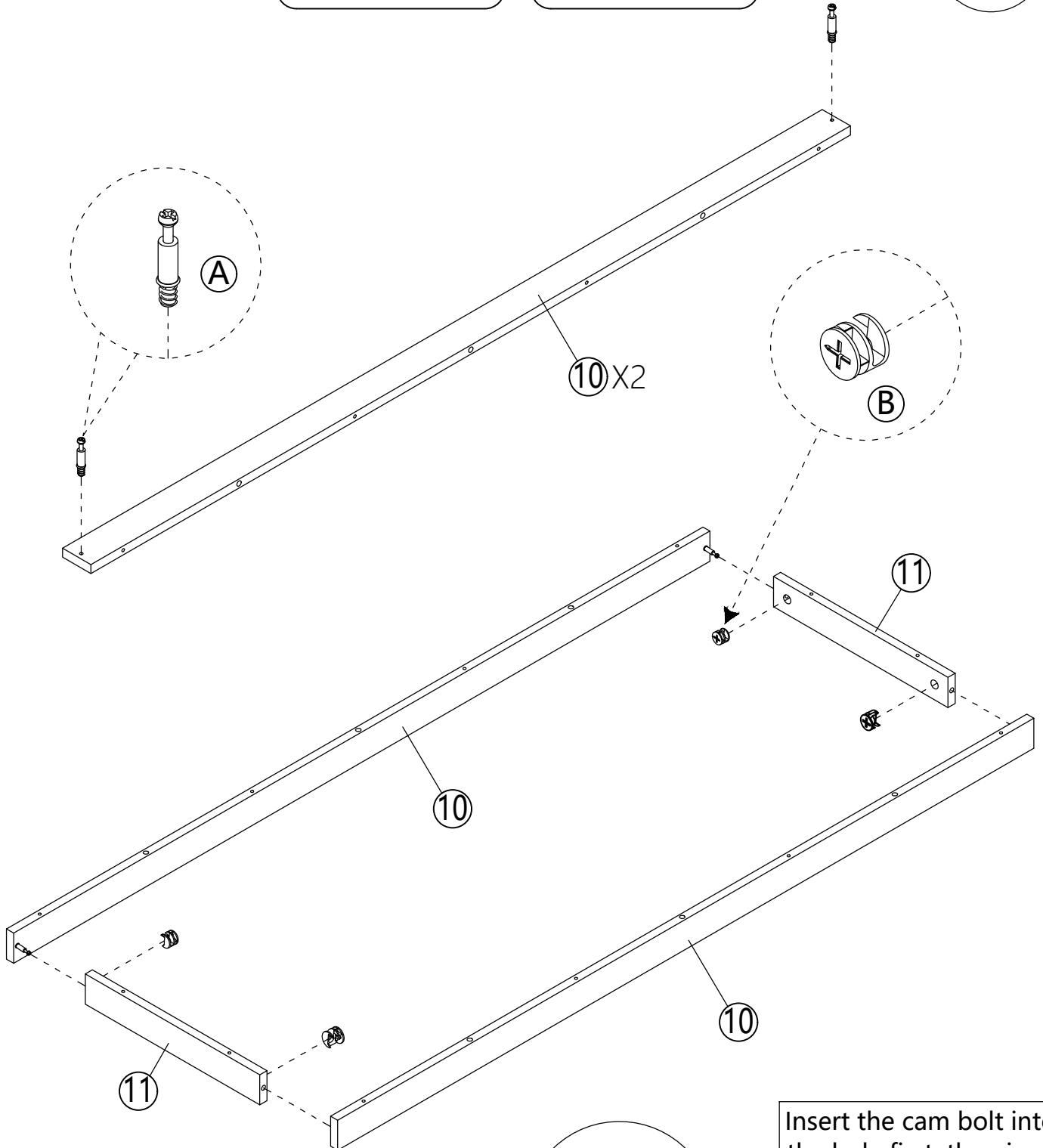
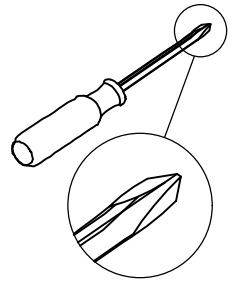

Insert the cam bolt into the hole first, then insert the cam lock and lock it.

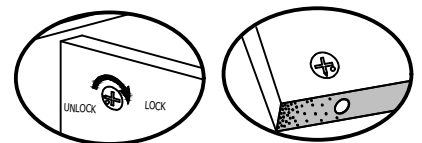

Proper orientation of CAM LOCK

# STEP 2

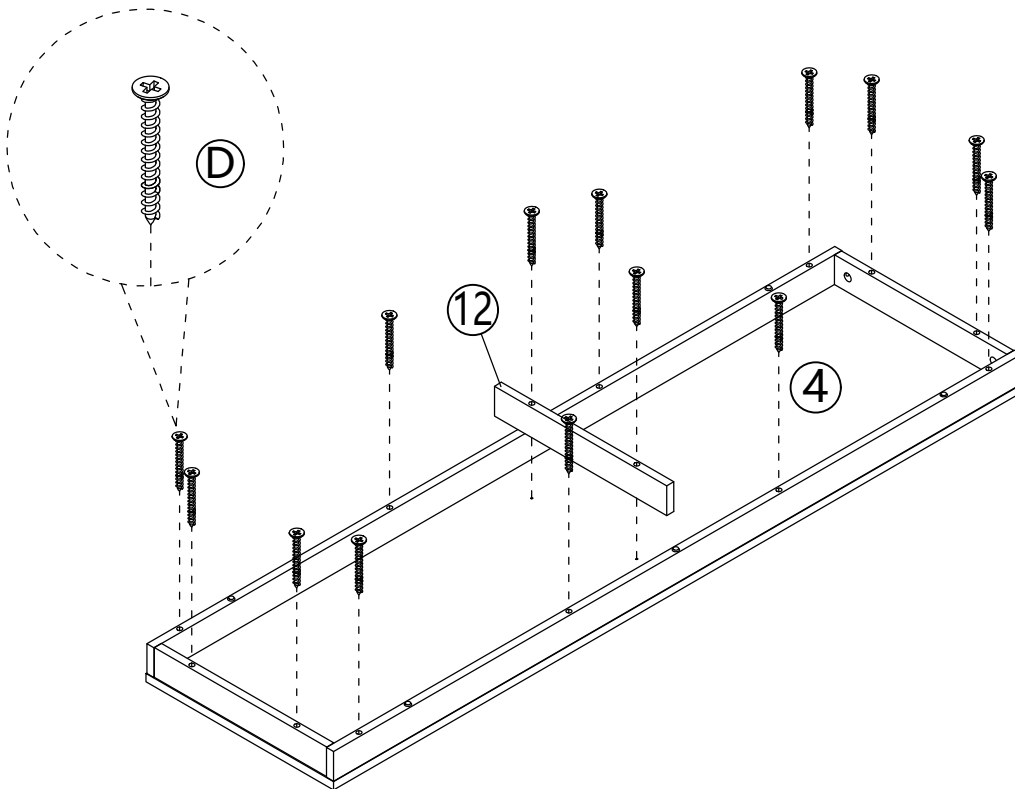
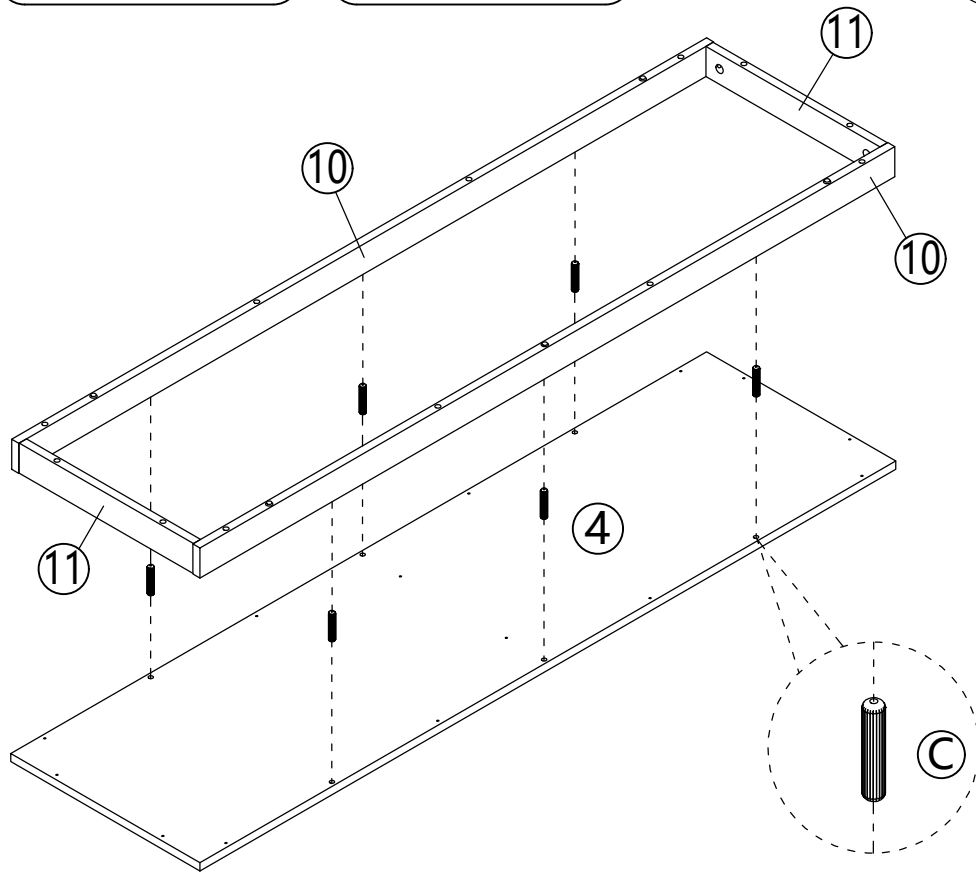
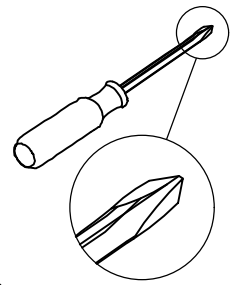
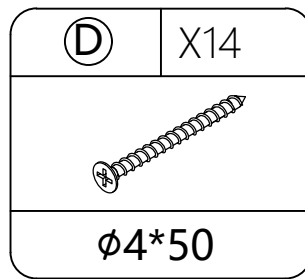
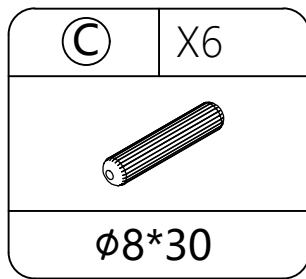

# STEP 3

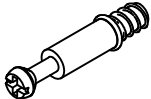
(A)	X23
	
ø6*35	

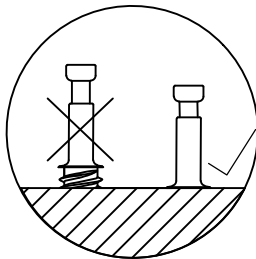
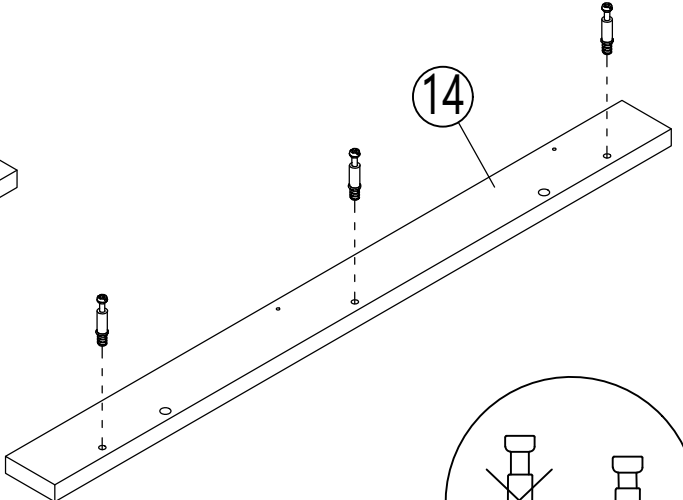
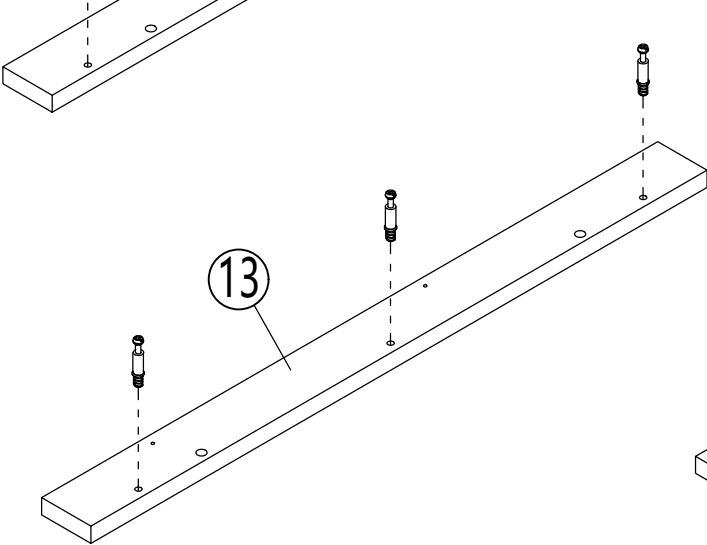
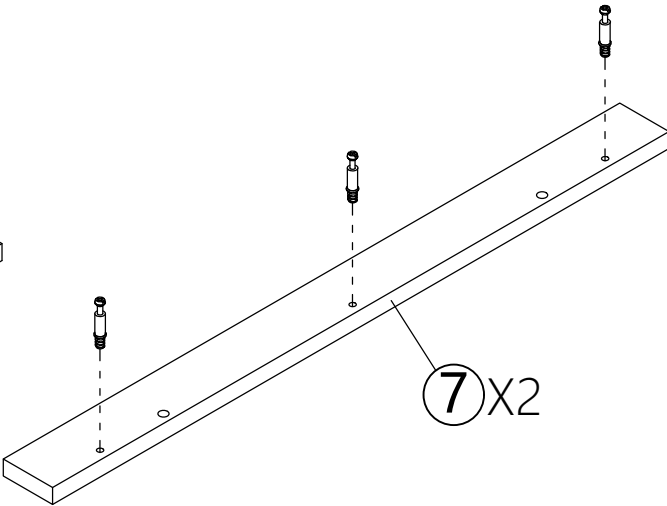
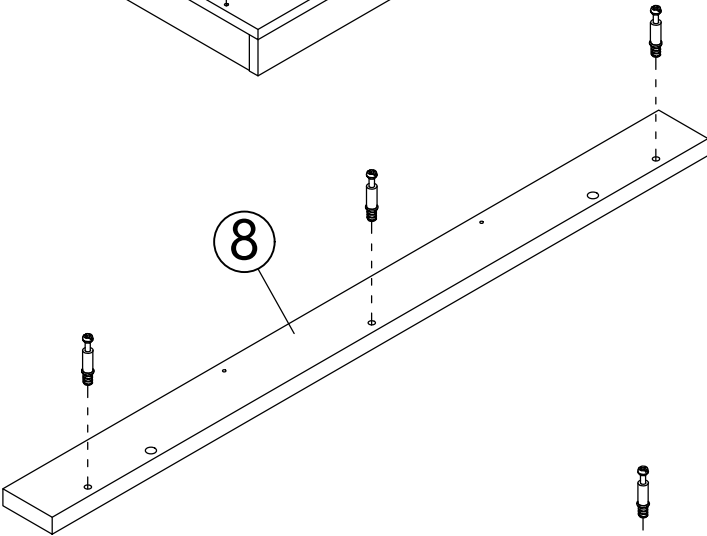
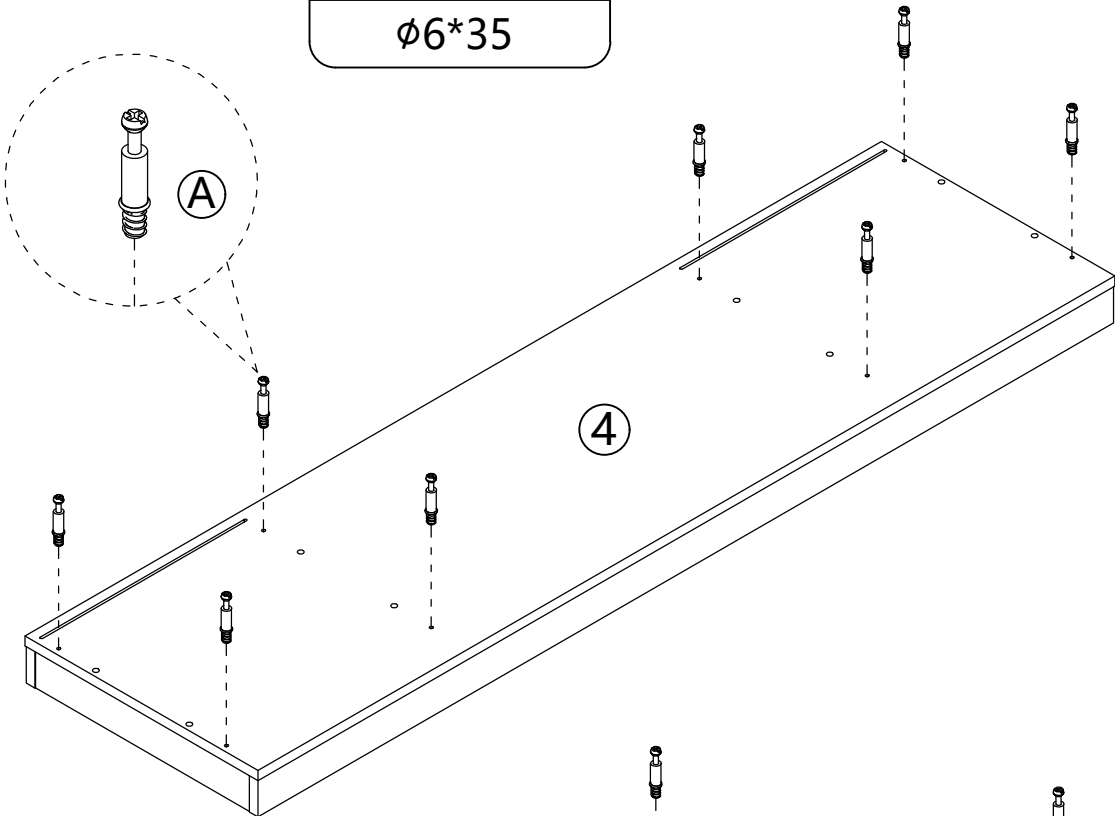
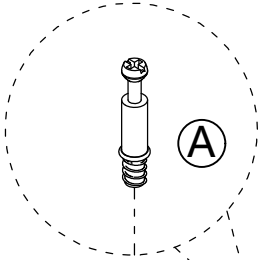
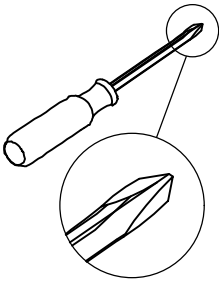

# STEP 4

(B)	X3
	
ø15*11.5	

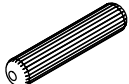
(C)	X6
	
ø8*30	

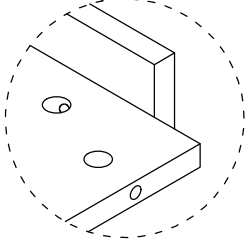
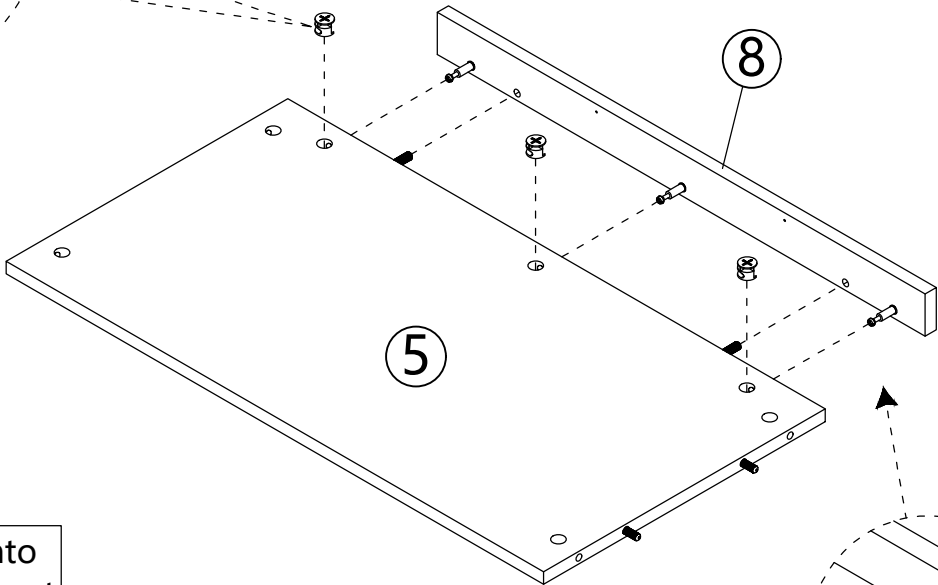
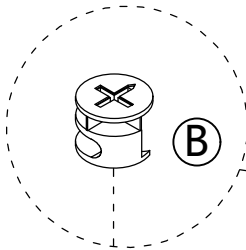
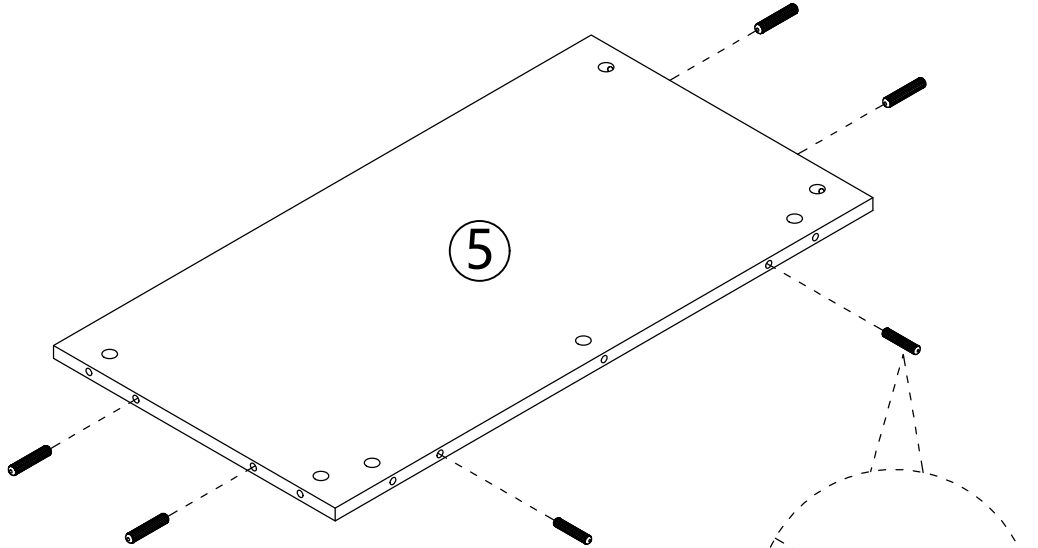
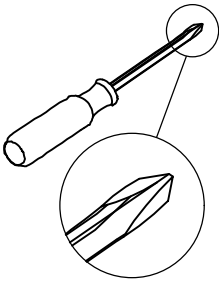

Insert the cam bolt into the hole first, then insert the cam lock and lock it.

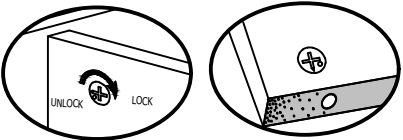

Proper orientation of CAM LOCK

**FINISH**

# STEP 5

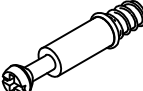
(A)	X4
	
$\phi 6 \times 35$	

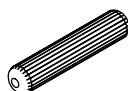
(C)	X24
	
$\phi 8 \times 30$	

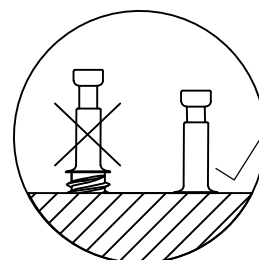
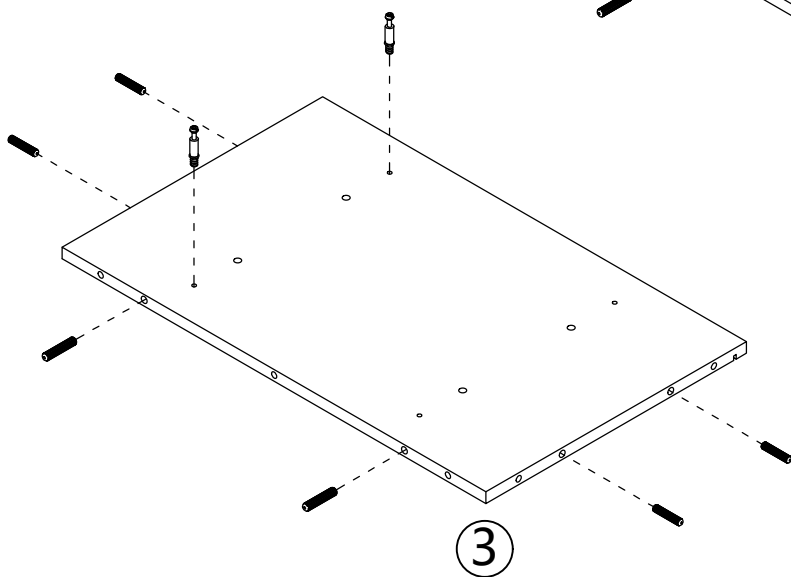
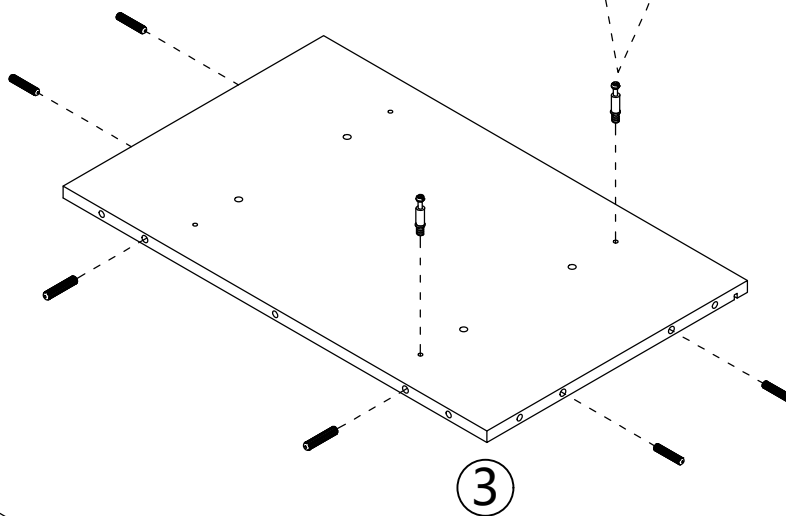
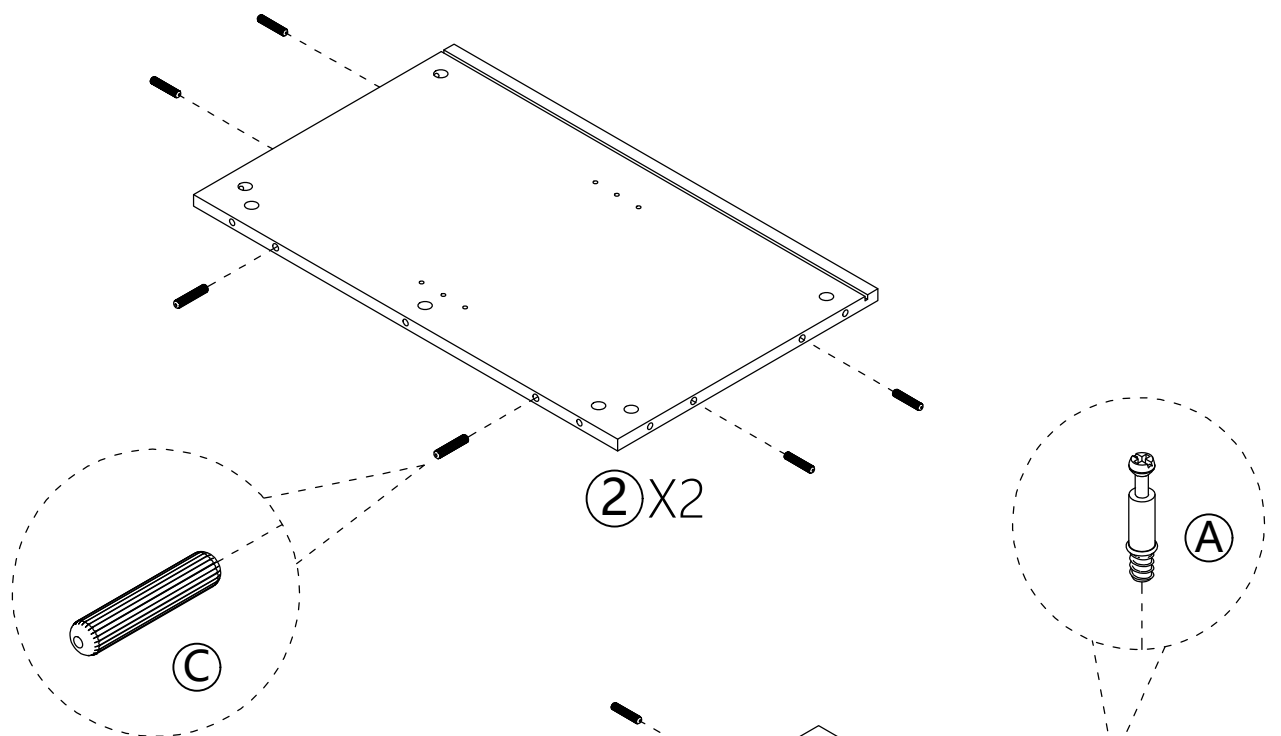
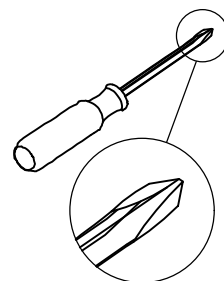

# STEP 6

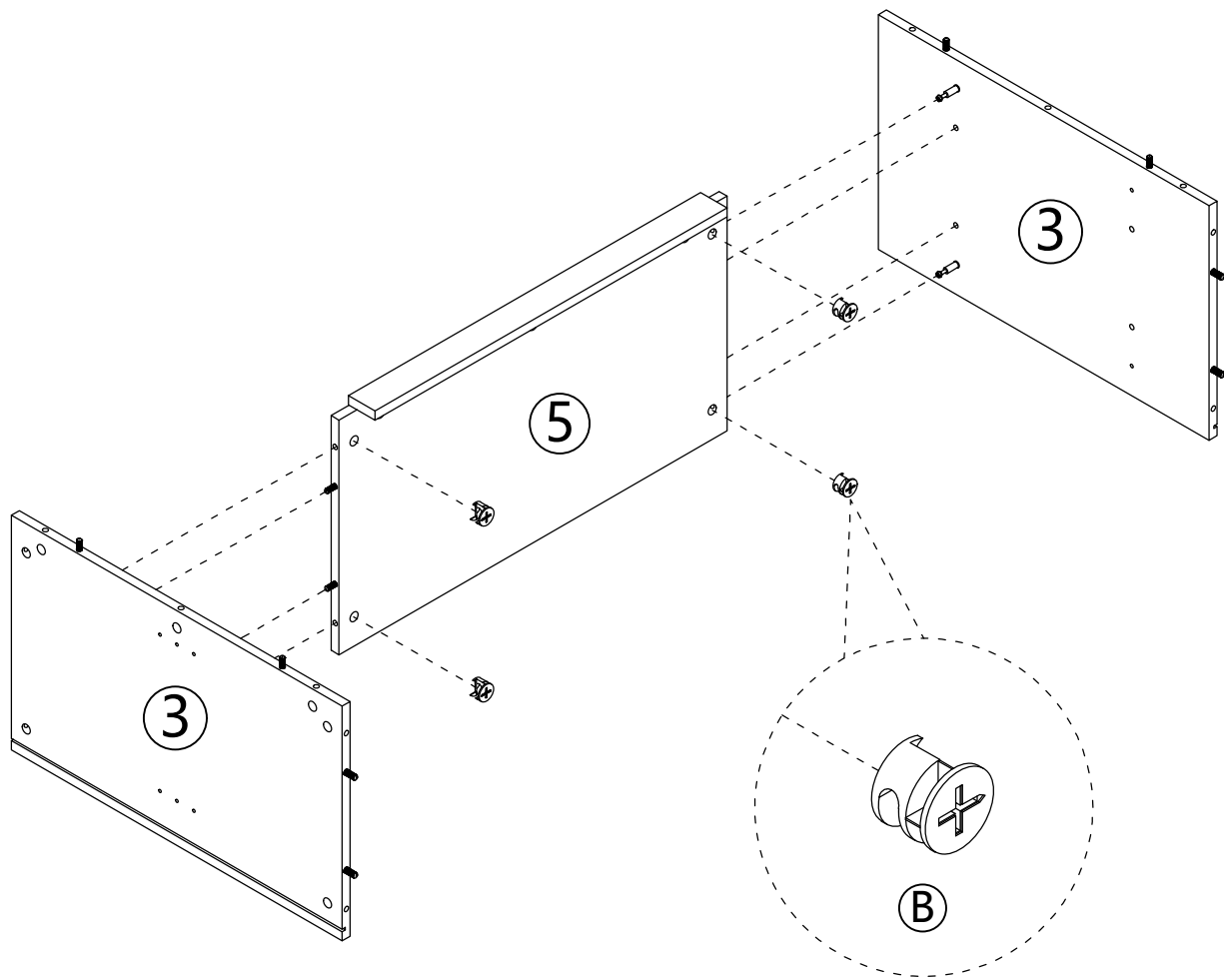
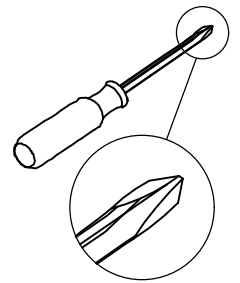
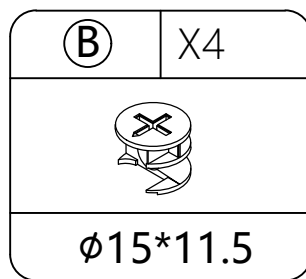

Insert the cam bolt into the hole first, then insert the cam lock and lock it.

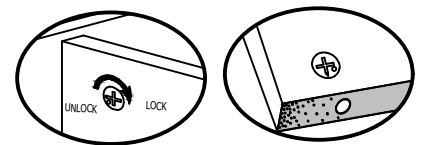

Proper orientation of CAM LOCK

# STEP 7

(B)	X6
	
ø15*11.5	

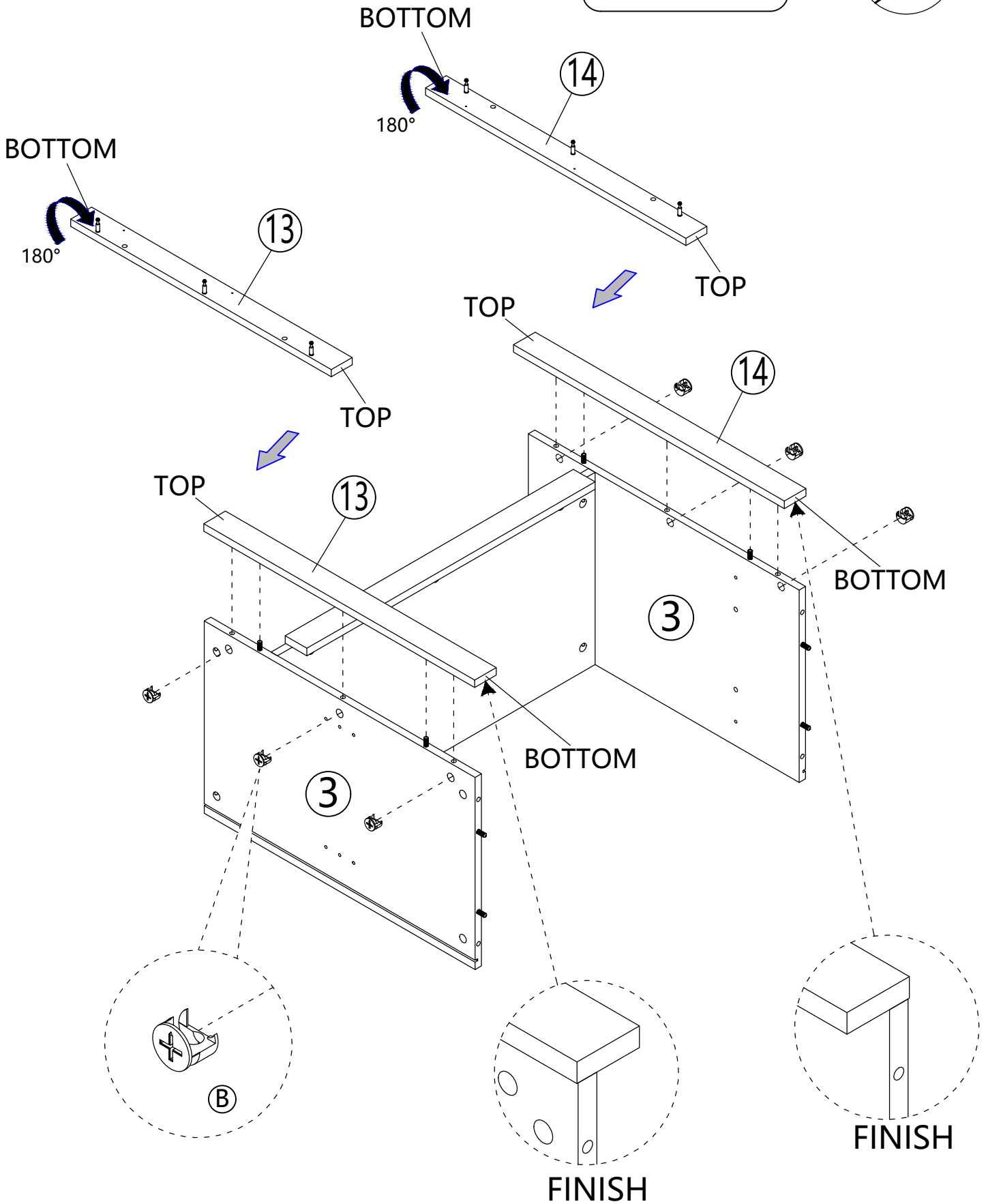
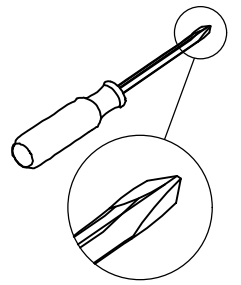

# STEP 8

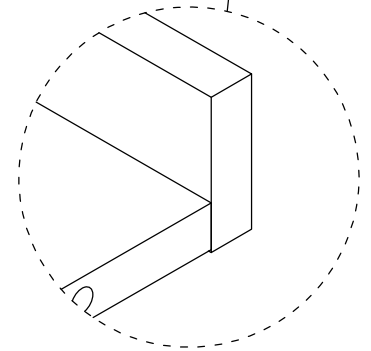
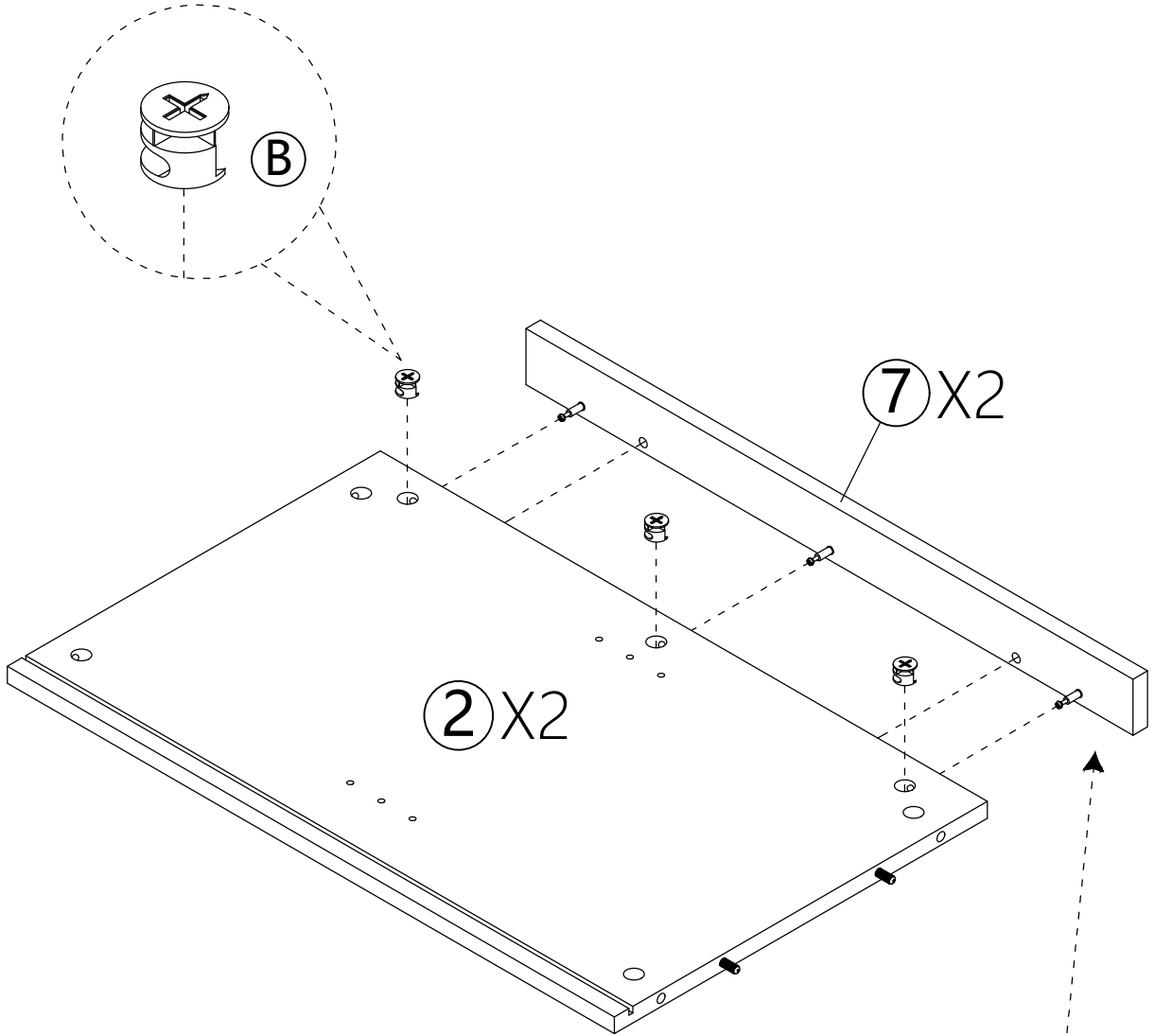
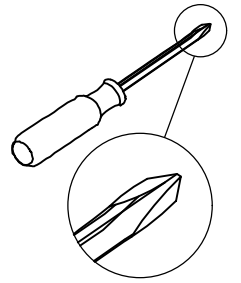
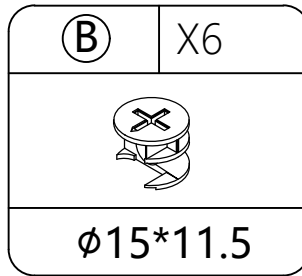

Insert the cam bolt into the hole first, then insert the cam lock and lock it.

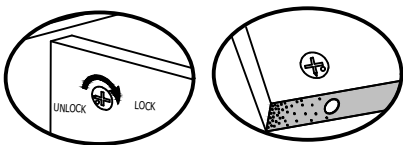

Proper orientation of CAM LOCK

# STEP 9

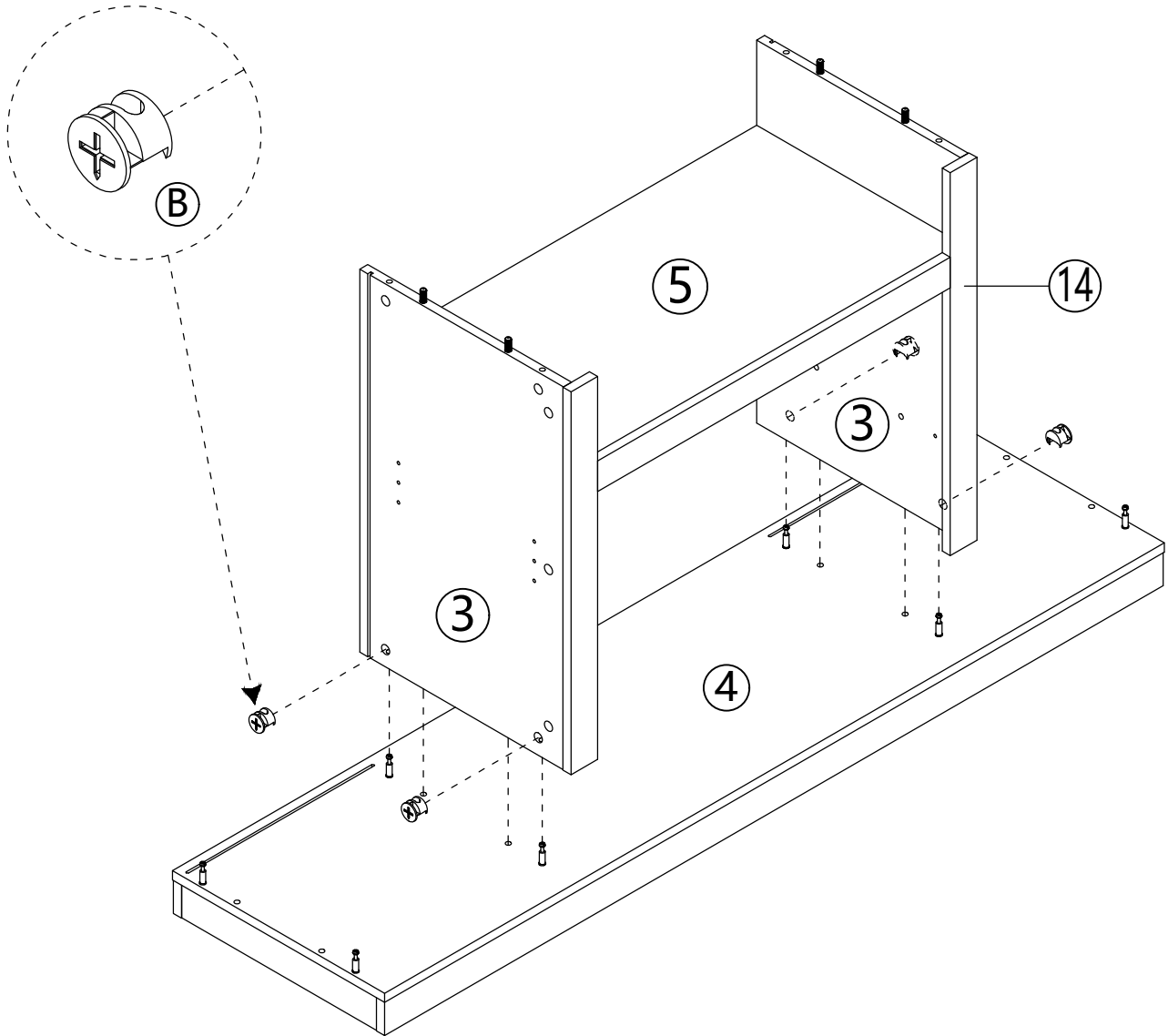
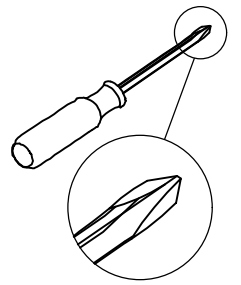
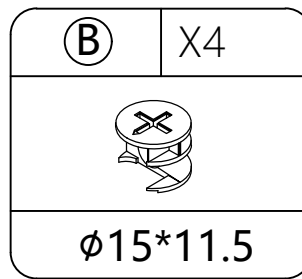

Insert the cam bolt into the hole first, then insert the cam lock and lock it.

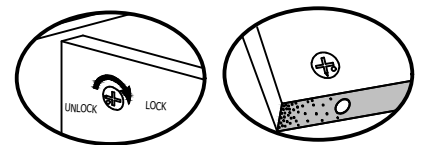

Proper orientation of CAM LOCK

# STEP 10

(B)	X4
	
ø15*11.5	

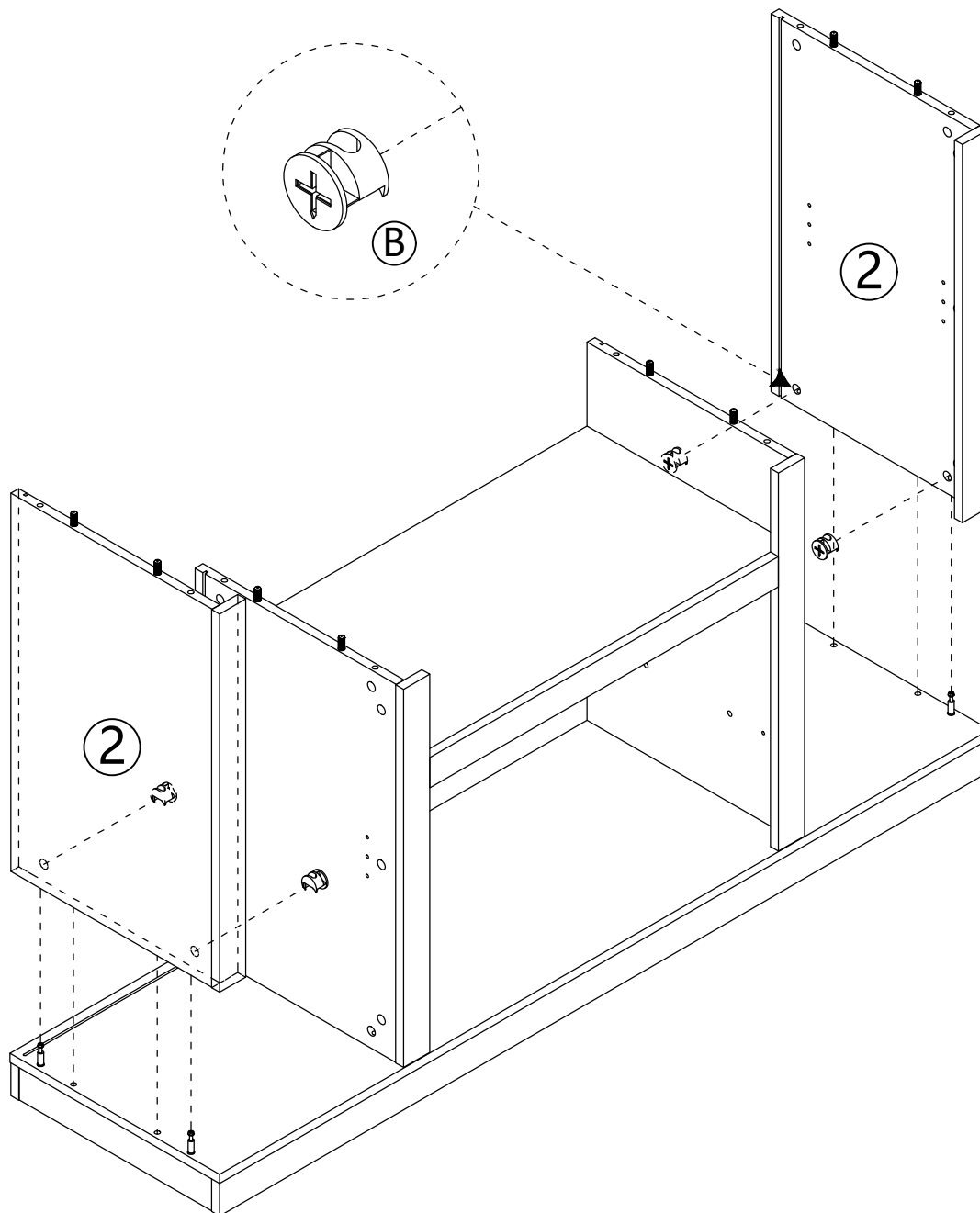
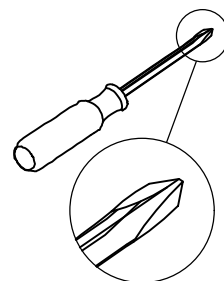

Insert the cam bolt into the hole first, then insert the cam lock and lock it.

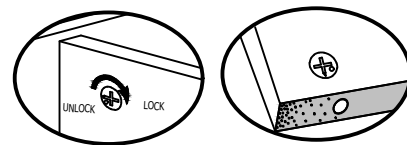

Proper orientation of CAM LOCK

# STEP 11

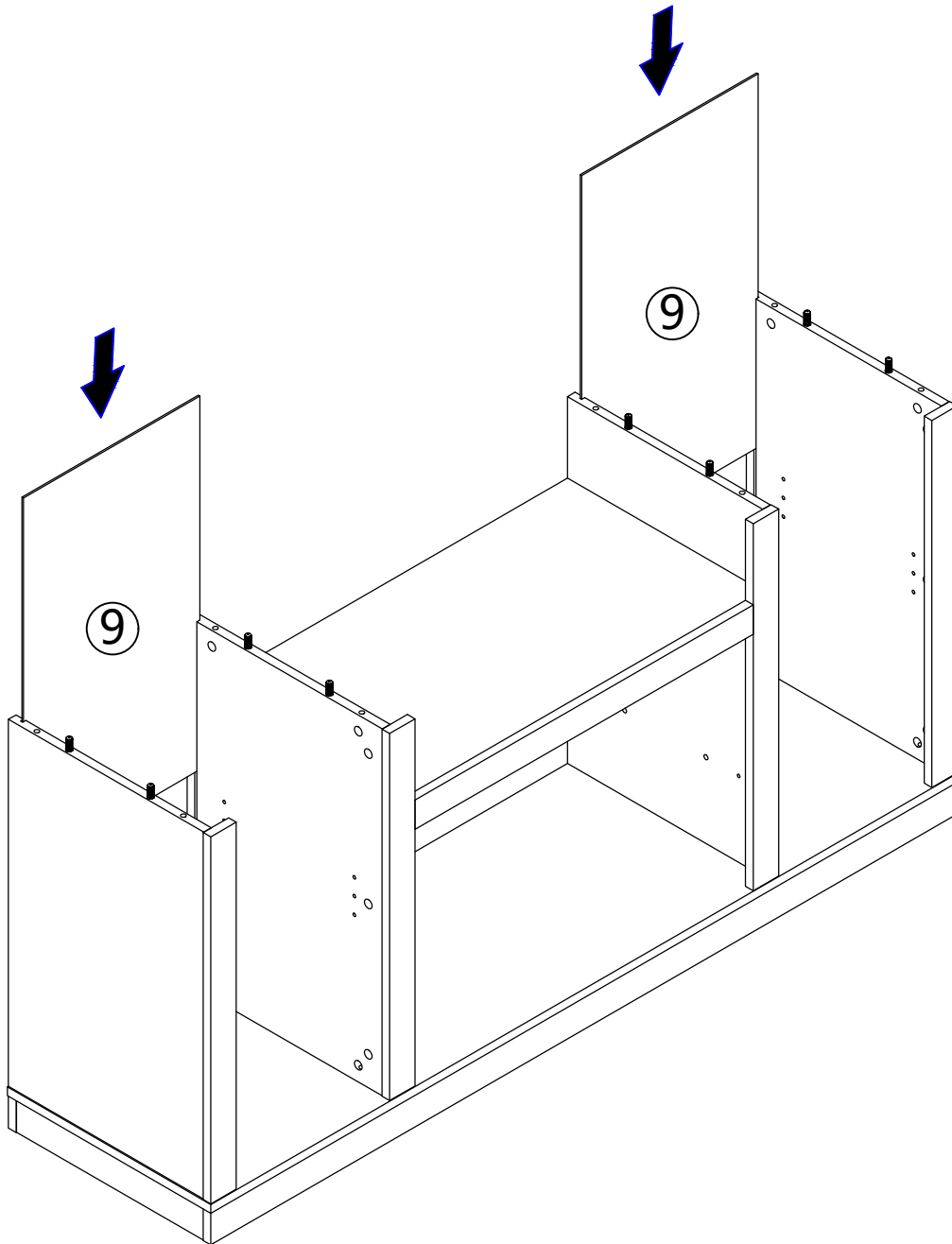

# STEP 12

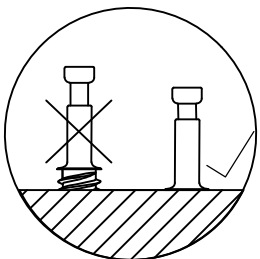
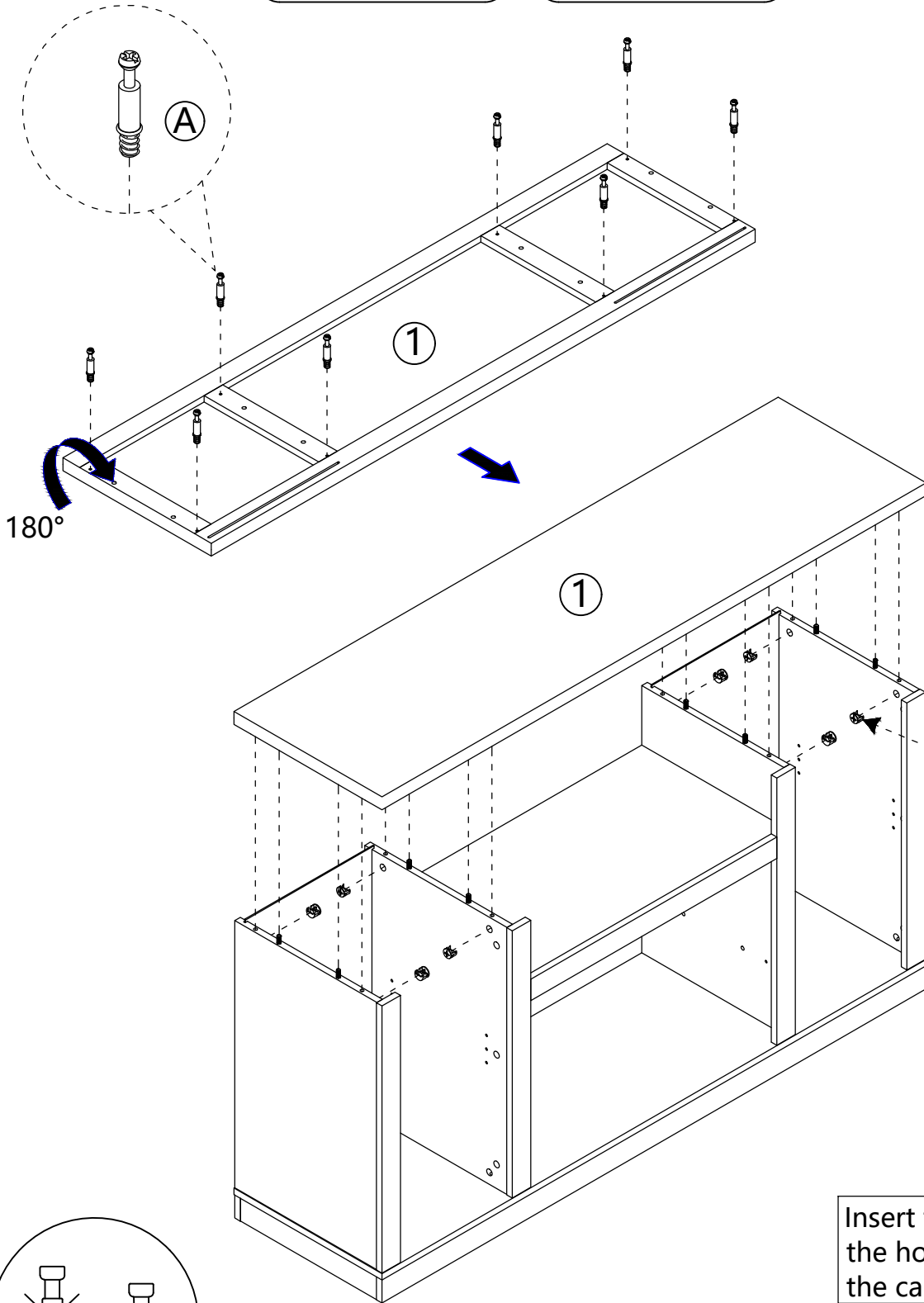
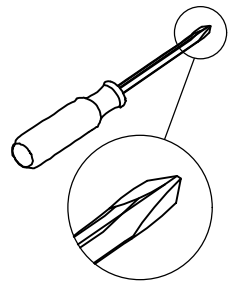
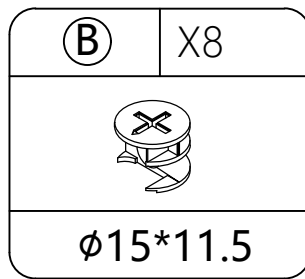
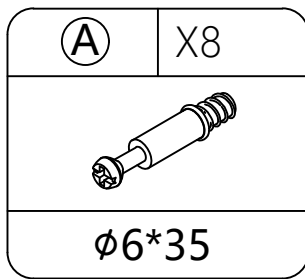

Insert the cam bolt into the hole first, then insert the cam lock and lock it.

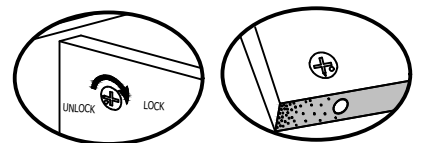

Proper orientation of CAM LOCK

# STEP 13

(E)	X8
	
ø5*16	

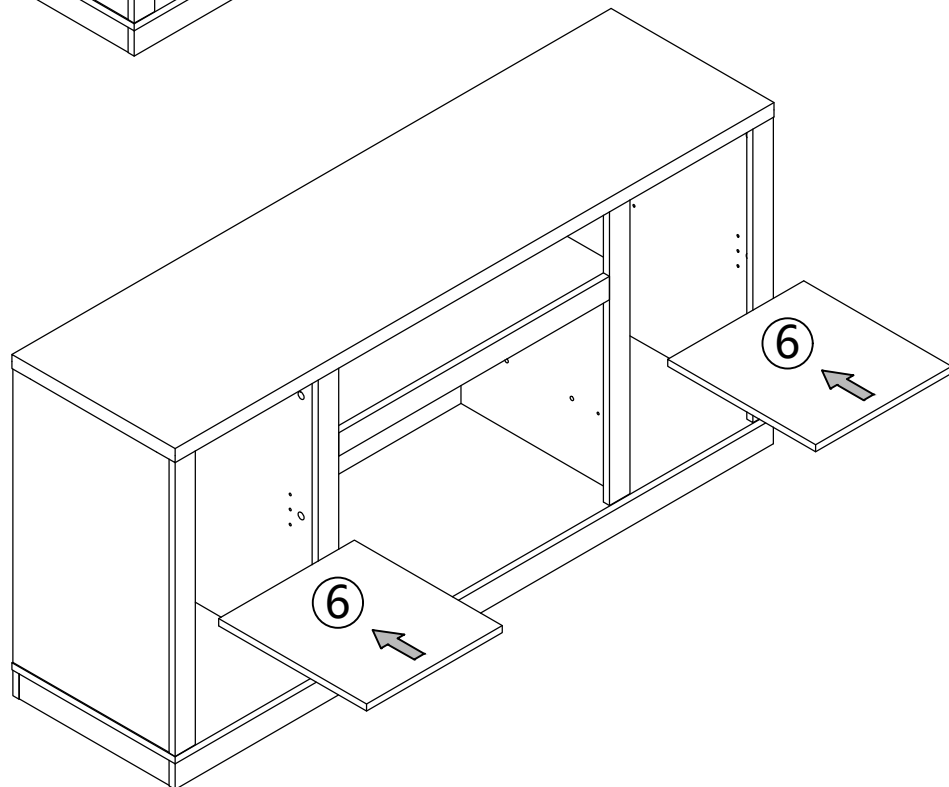
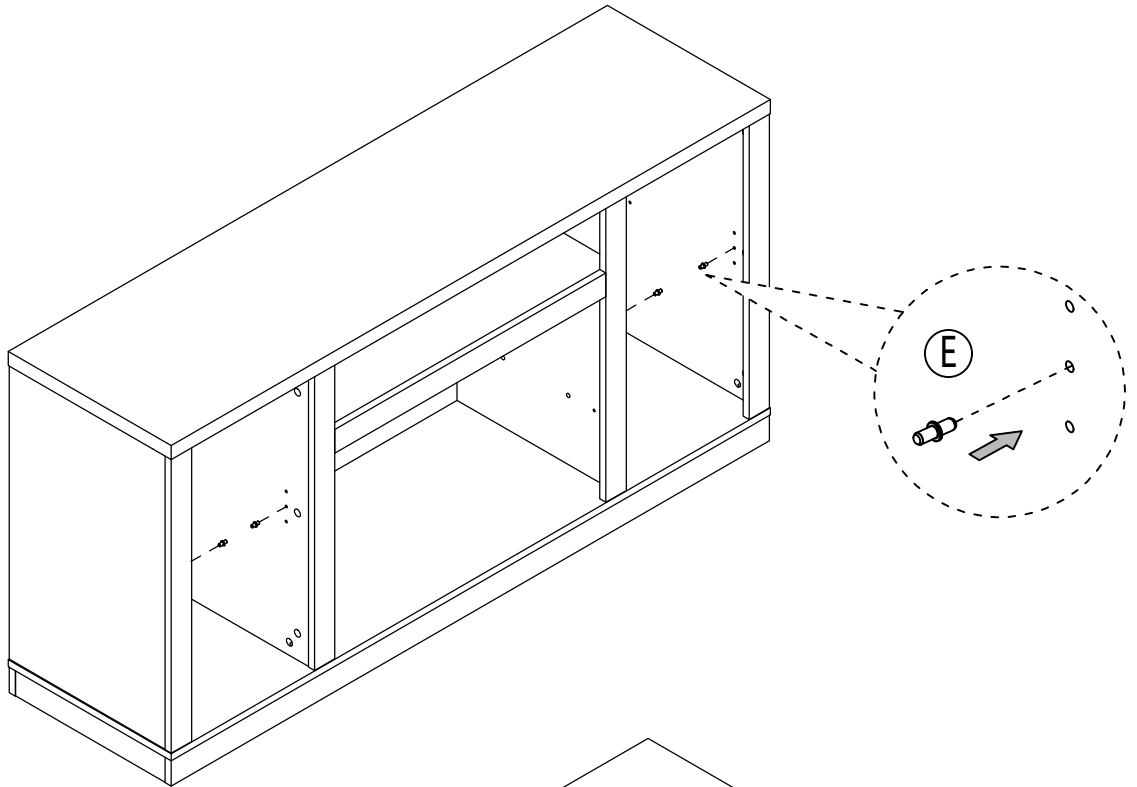

# STEP 14

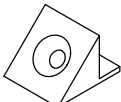
(F)	X12
	
Ø3*14	

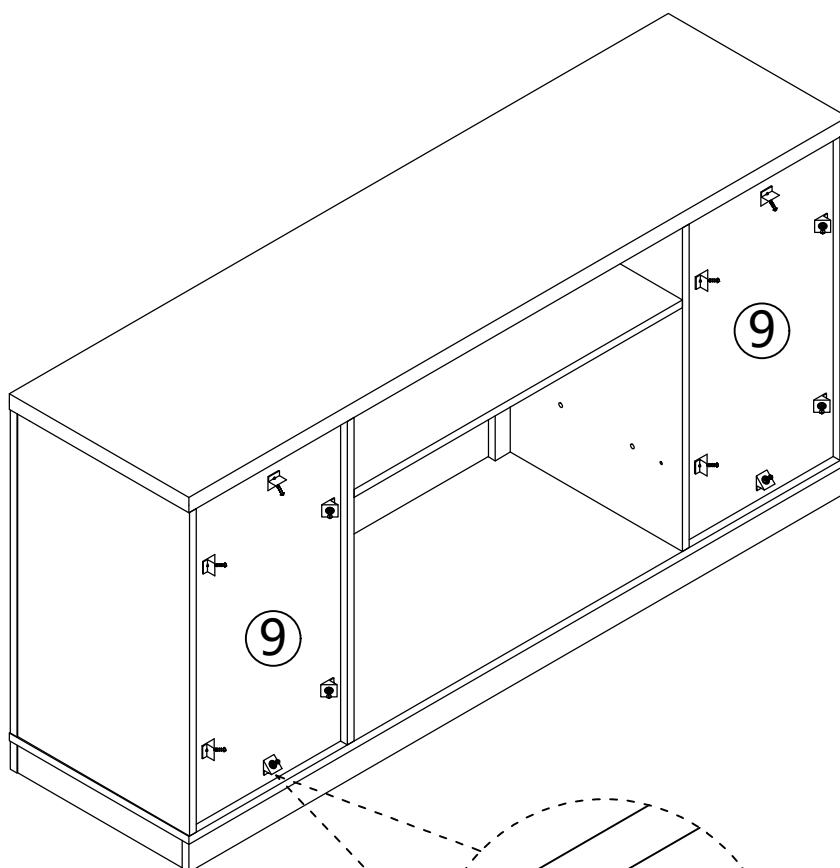

**FINISH!**

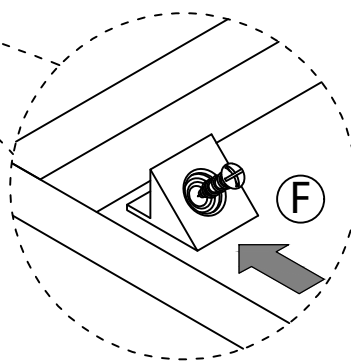

Insert the plastic buckle into the back plate slot, screw through the hole in the plastic buckle and lock it in place.

# STEP 15

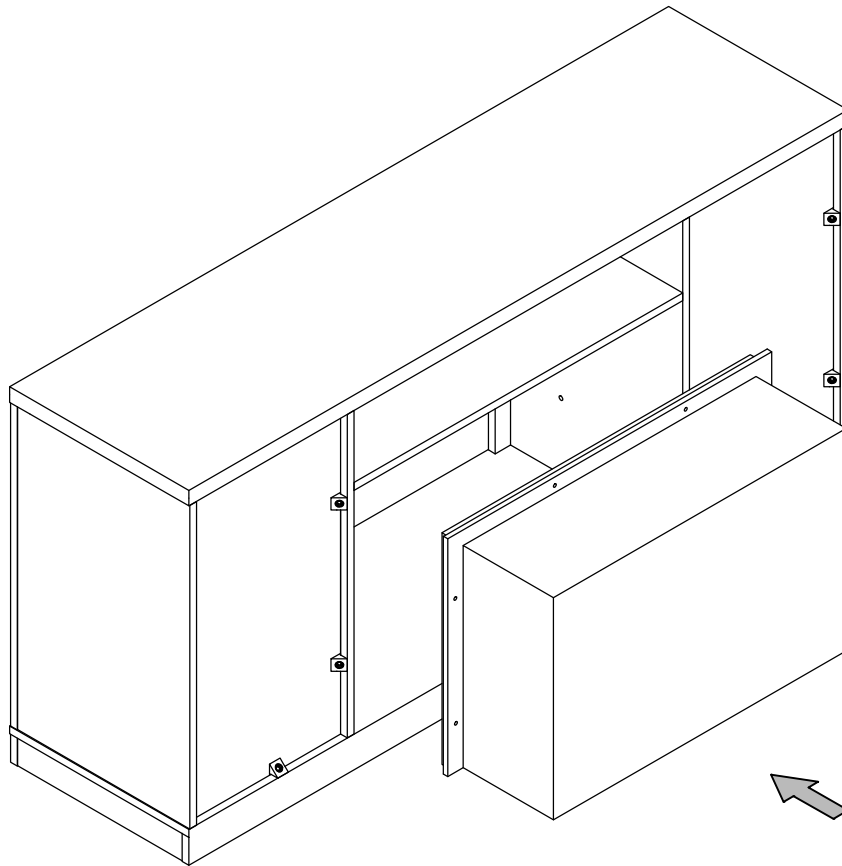

# FURNITURE CARE AND MAINTENANCE

## Particleboard

Thank you for your purchase. We want your item to last as long as possible. To ensure the product gives you years of service, please refer to this care and maintenance guide.

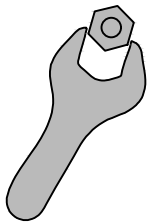

### MAINTENANCE

- . Tighten all bolts and screws again within the first 2 weeks of assembly
- . Check the tightness of all bolts every 2 months, tighten them if necessary



### CLEANING

- . Clean the surface of the particleboard with a lightly dampened cloth
- . Small amount of mild soap can be used if necessary
- . Dry the surface immediately after cleaning.
  
- . DO NOT use bleach or alcohol detergent to clean the surface.
- . DO NOT apply wood treatment on parts made with particleboard.

Particleboard will swell and distort when suffer damage.  
Make sure to dry the furniture immediately after cleaning