

ADULT ASSEMBLY REQUIRED

KD CUBBY INSERT: 1434977

BIRD•IN•HAND

Woodworks, Inc.

Lancaster, Pennsylvania
A member of the School Specialty Family

Product Guide - General Instructions and Information

Customer Service:

P.O. Box 1579, Appleton, WI 54912-1579

Phone: 1-888-388-3224

Customer Care Website:

<https://help.schoolspecialty.com/s/>

Warning:

This product is for children. Supervision is required at all times.

Warning:

Manufacturer is not responsible for changes made to our products by customers.

Cleaning:

Use a mild soap and water solution. Be sure to wipe all water from the wood surface.

Important:

Keep these instructions for future reference.

STEP 1: POSITION BOTTOM PANEL

Position a shelf panel as shown so that the slots are facing towards the back of the cabinet.

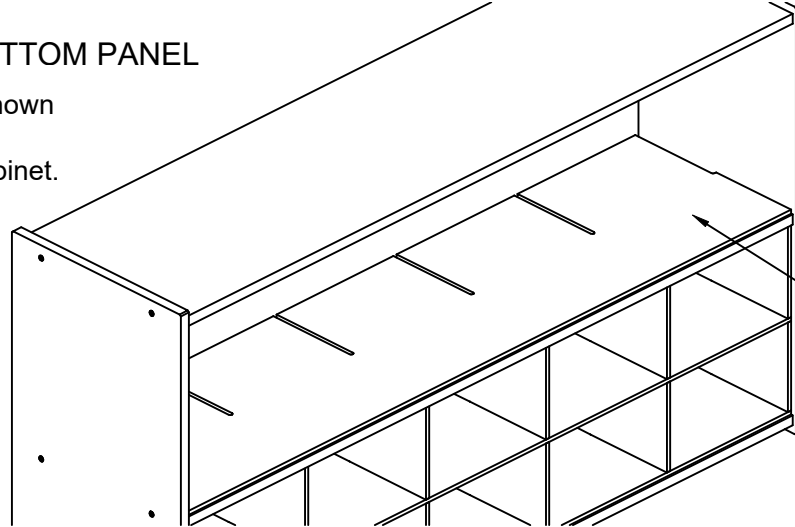

SHELF PANEL
(#508236)

STEP 2: INSERT AND ALIGN DIVIDERS

Insert each divider so that the slots are facing towards to front edge of the cabinet. (The tabs should fit into the slots of the shelf panel.)

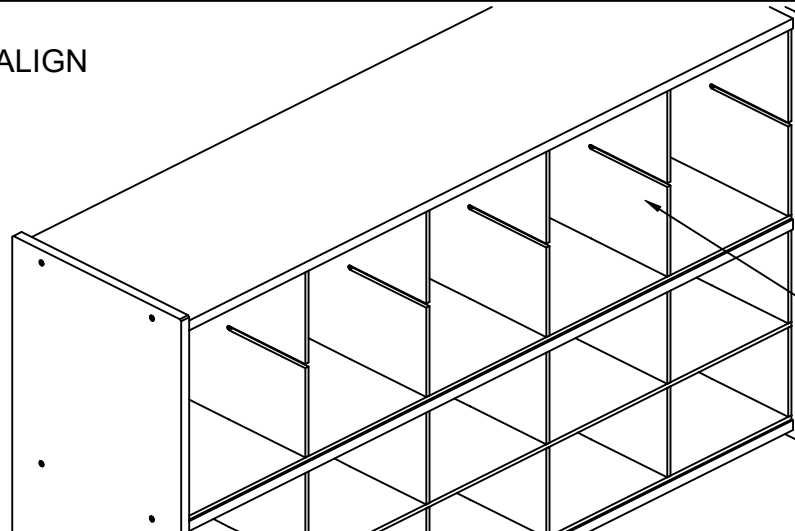

DIVIDER
(#508237 - 6 pcs.)

STEP 3: INSERT REMAINING SHELF AND TOP PANEL

Insert the remaining shelf panel as shown. It might be necessary to jiggle the shelf slightly in order to align with the slots in the dividers.

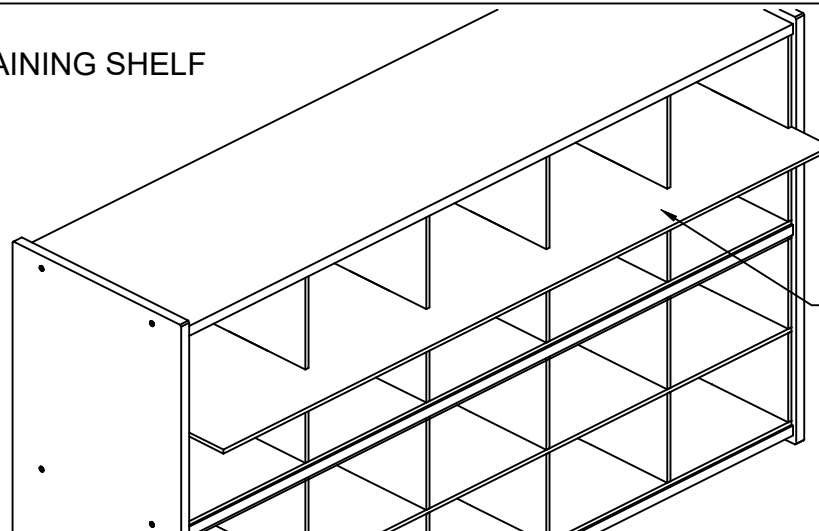

SHELF PANEL
(#508236 - 1 pc.)