

SKU: LI008701

LI008801

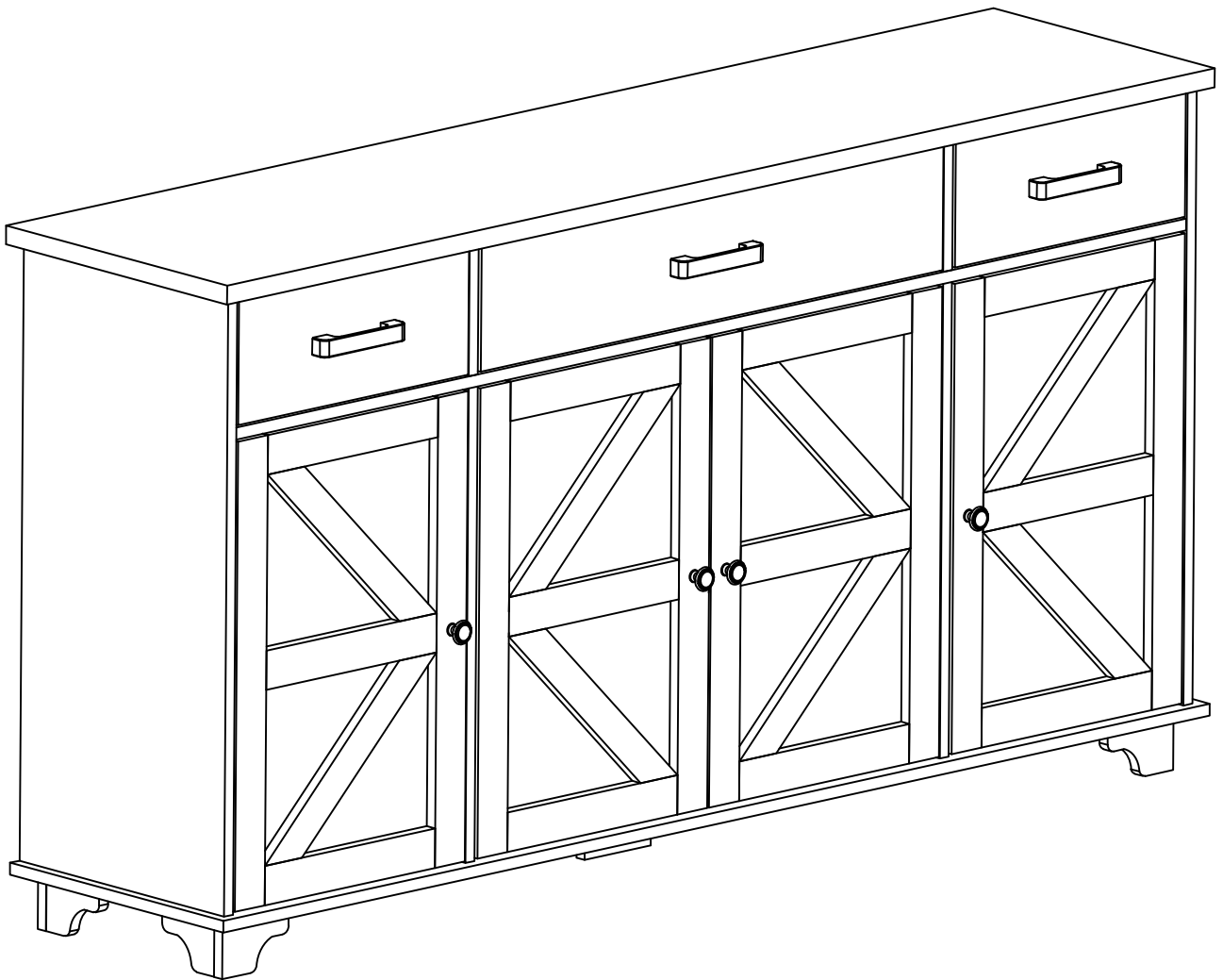

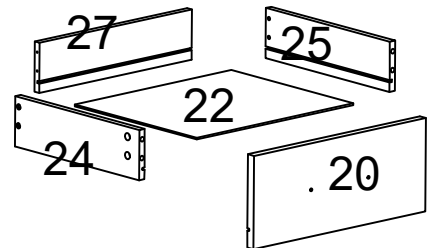
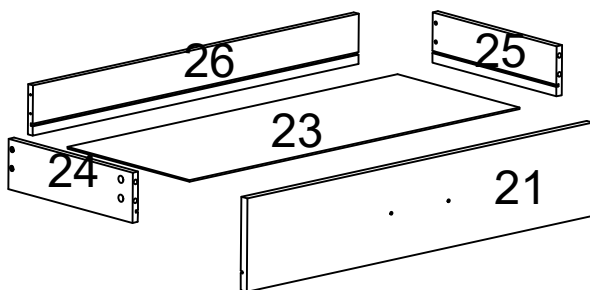
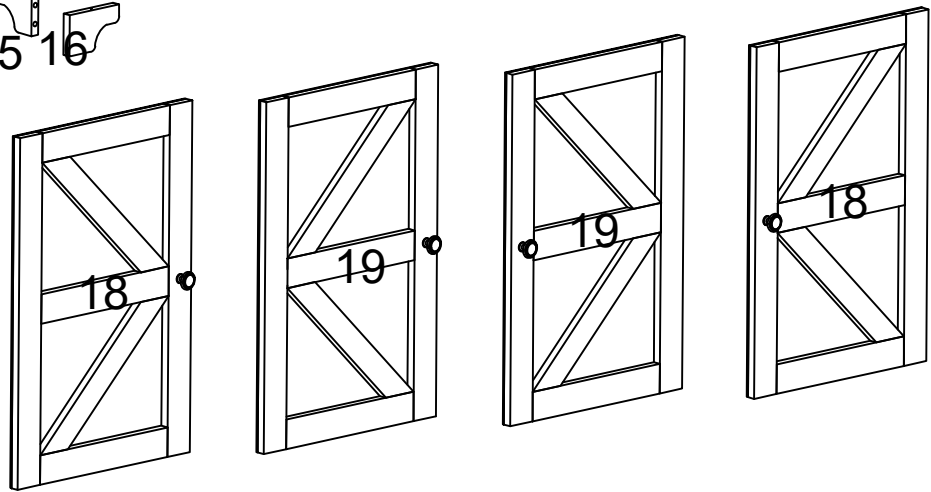
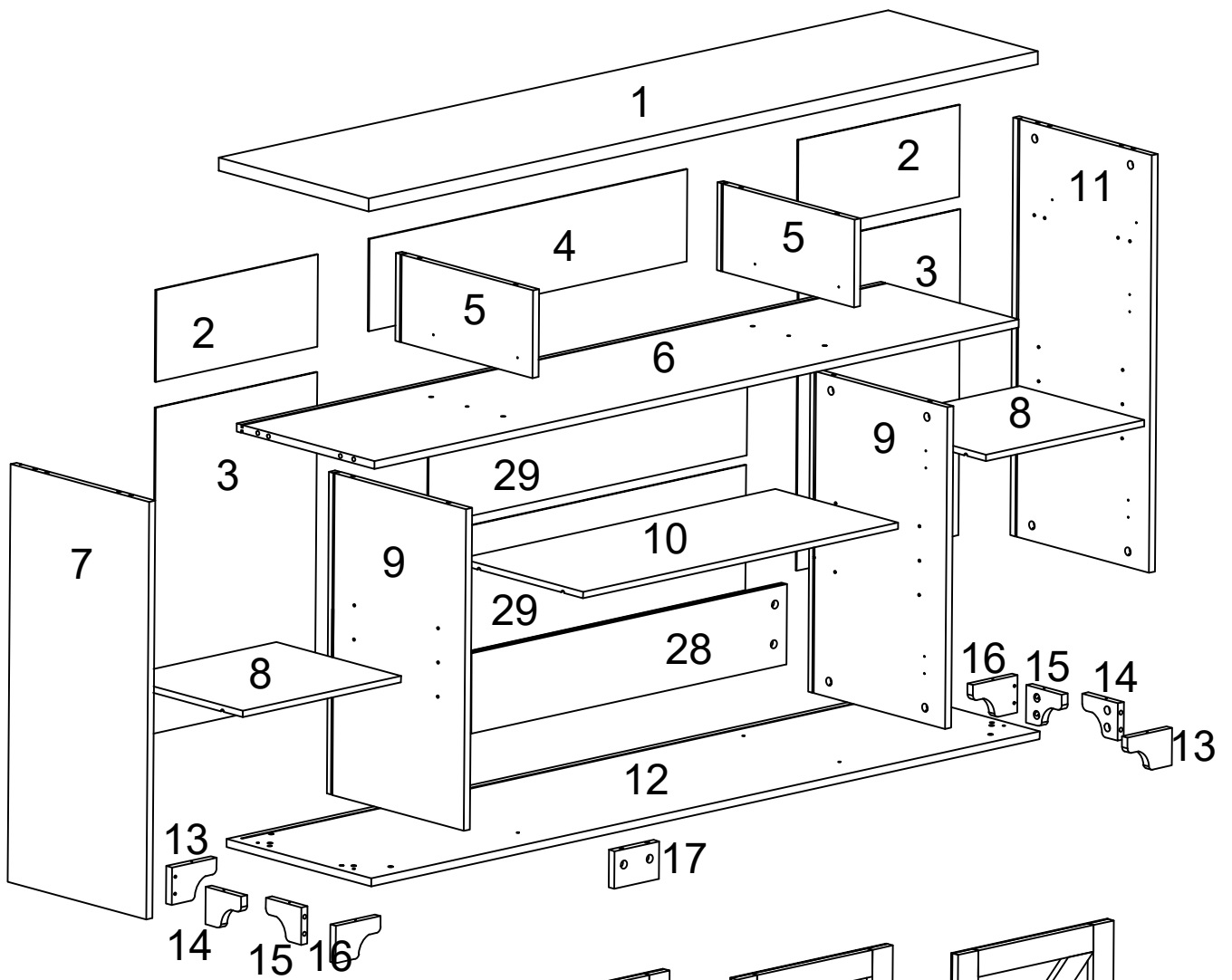

x2PCS

# Trouble Shooting

Missing/Damaged pieces/  
Wrong size and installation issues



Contact us with your problem, pic,  
number and qty to the "Contact seller"  
button in the detail page of your order



Respond with 24 hours to solve issue

# Before You Start

1. Read through each step carefully and follow the proper order
2. Separate and count all your parts and hardware
3. Give yourself enough room for the assembly process
4. Caution: If using a power drill or power screwdriver for screwing, please be aware to slow down and stop when screw is tight. Failure to do so may result in stripping the screw

## Cam Lock Fastening System

This Cam Lock Fastening System will be used throughout the assembly process

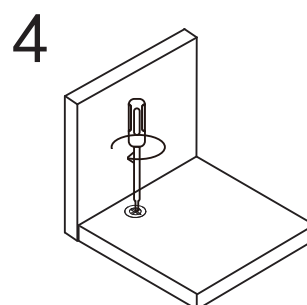
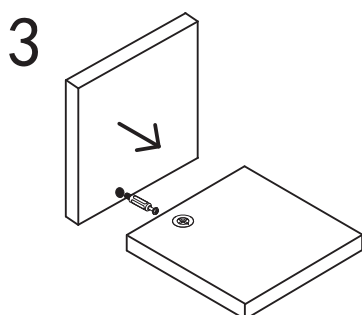
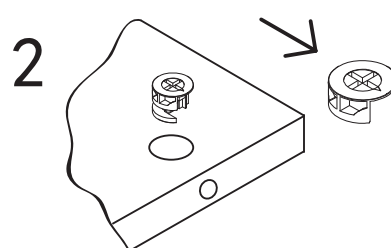

# Parts List

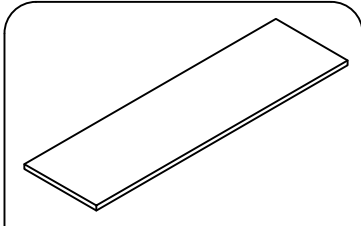

1 1PC

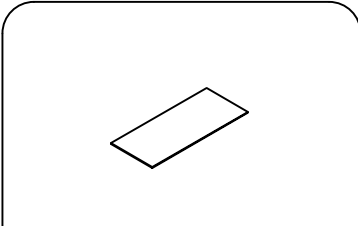

2 2PC

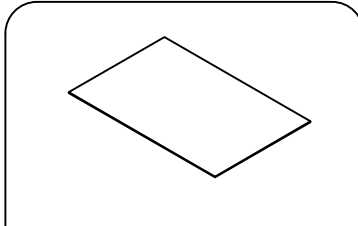

3 2PC

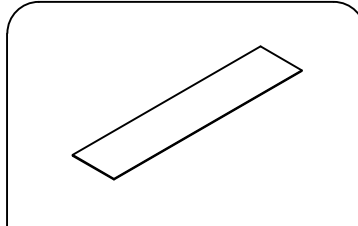

4 1PC

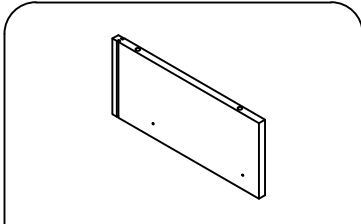

5 2PC

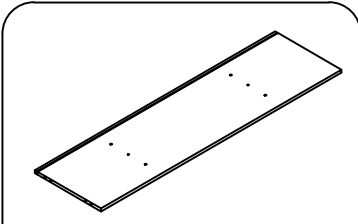

6 1PC

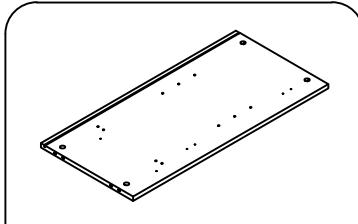

7 1PC

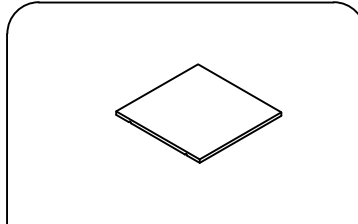

8 2PC

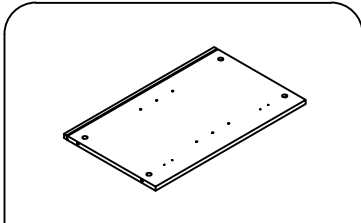

9 2PC

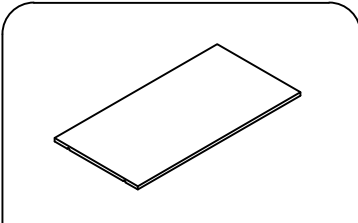

10 1PC

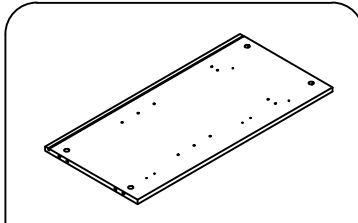

11 1PC

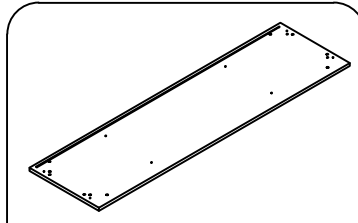

12 1PC

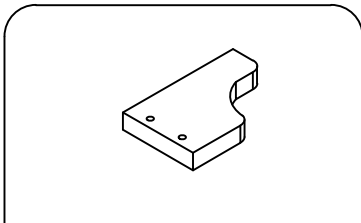

13 2PC

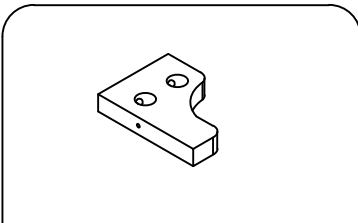

14 2PC

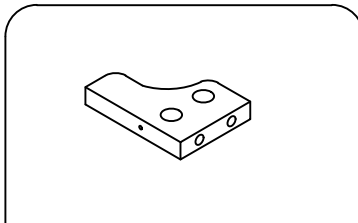

15 2PC

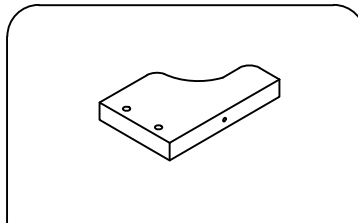

16 2PC

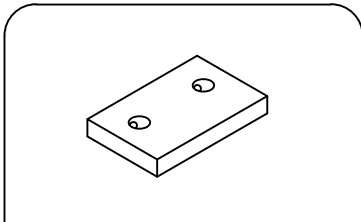

17 1PC

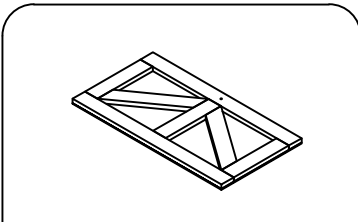

18 2PC

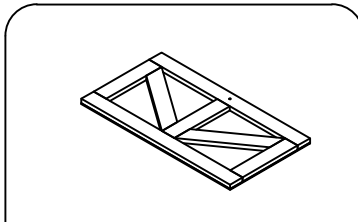

19 2PC

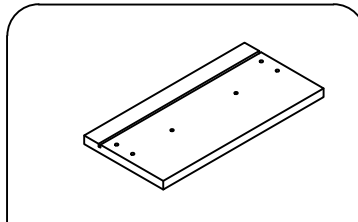

20 2PC

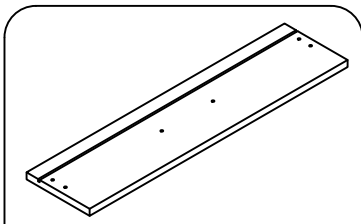

21 1PC

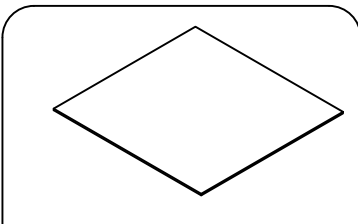

22 2PC

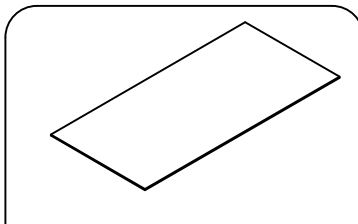

23 1PC

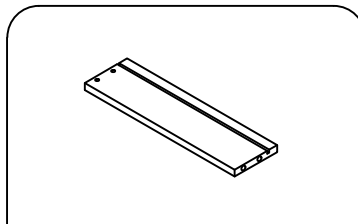

24 3PC

# Parts List

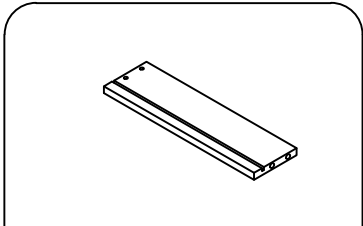

25	3PC
----	-----

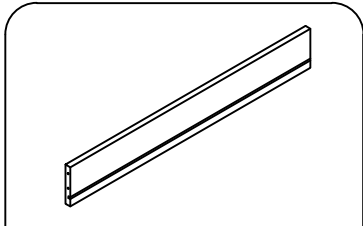

26	1PC
----	-----

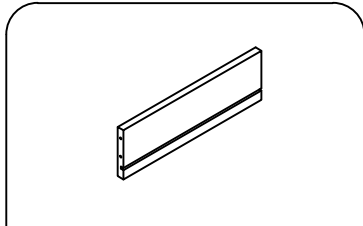

27	2PC
----	-----

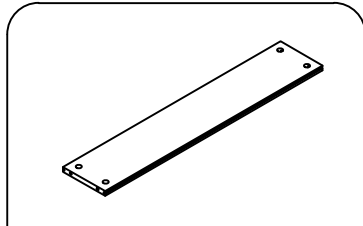

28	1PC
----	-----

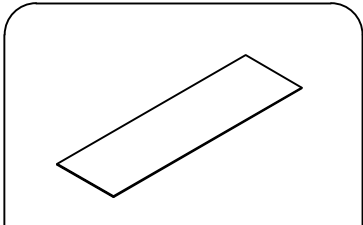

29	2PC
----	-----

# Hardware List



A

50PC

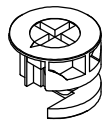

Ø15

B

38PC



Ø8\*30mm

C

16PC

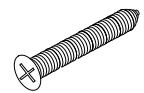

Ø4\*40mm

D

22PC



E

4PC



M4\*18mm

F

6PC



Ø3.5\*14mm

G

32PC



Ø3\*12mm

H

24PC

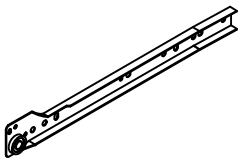

I

3PC

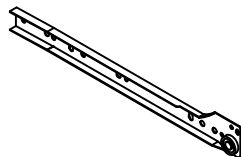

J

3PC

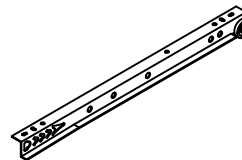

K

3PC

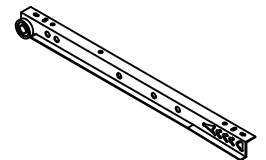

L

3PC

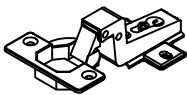

M

8PC

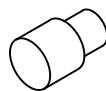

N

12PC

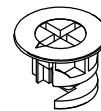

Ø12

O

12PC

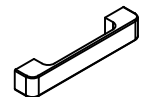

P

3PC



M4\*22mm

Q

4PC

# STEP 1

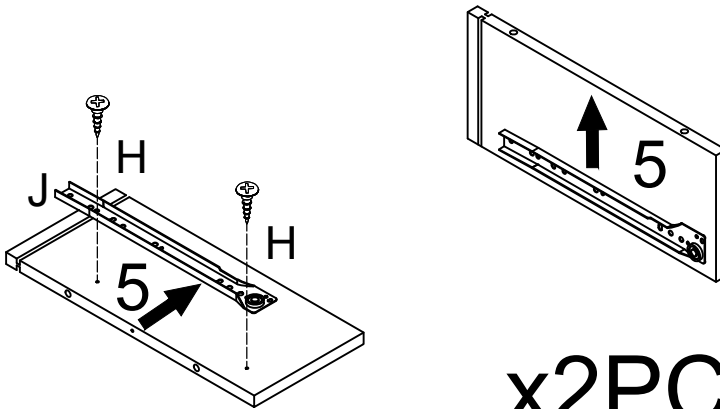
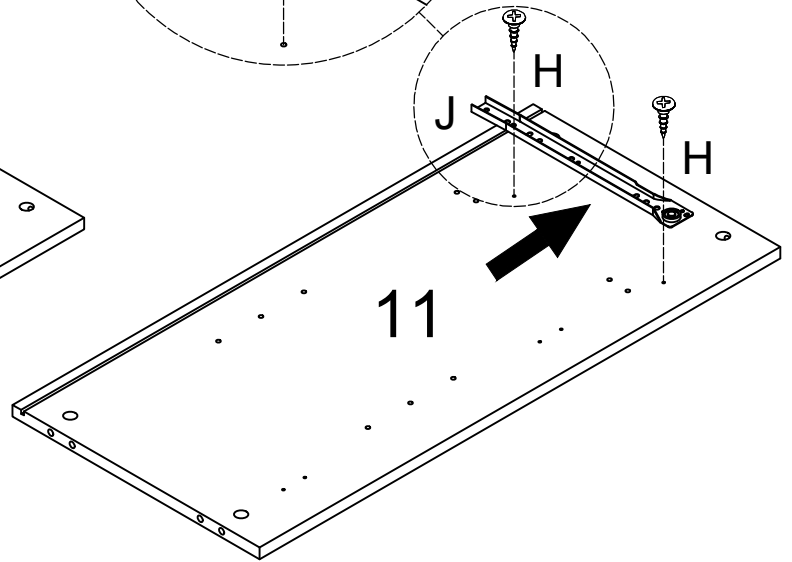
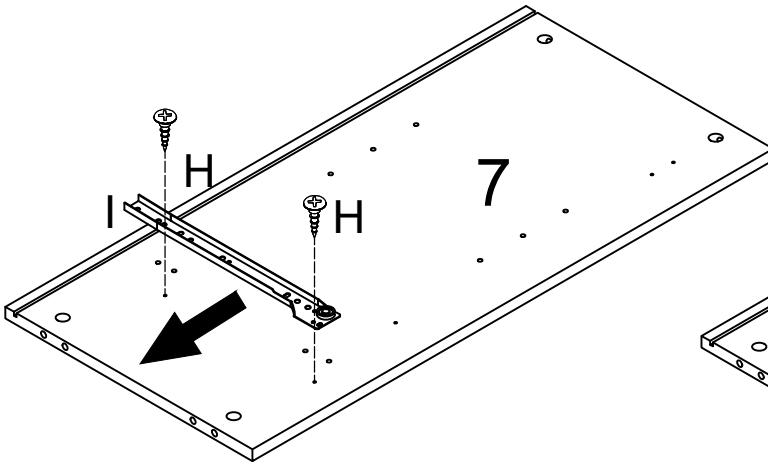
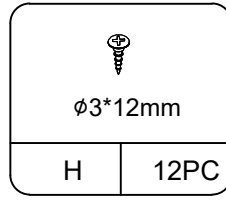
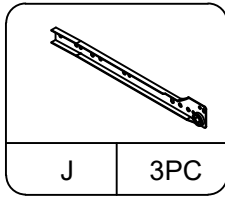
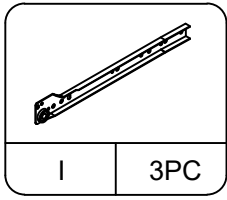

x2PCS

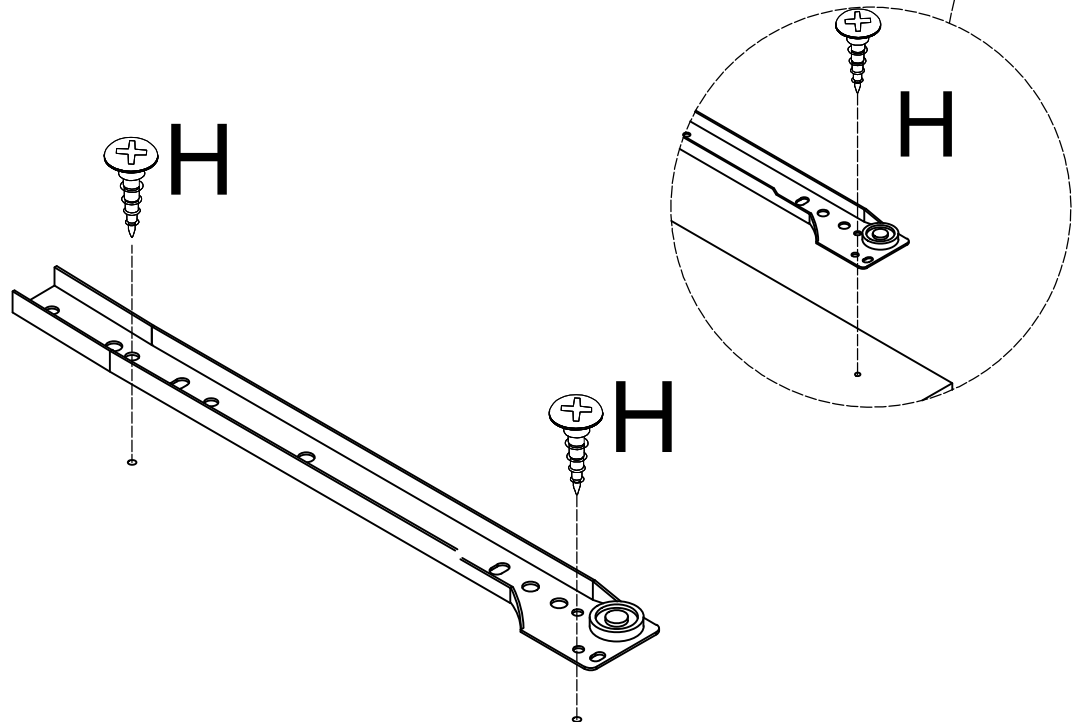
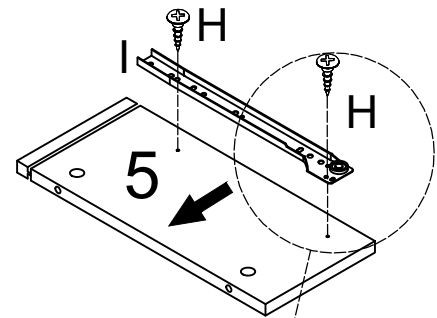

# STEP 2

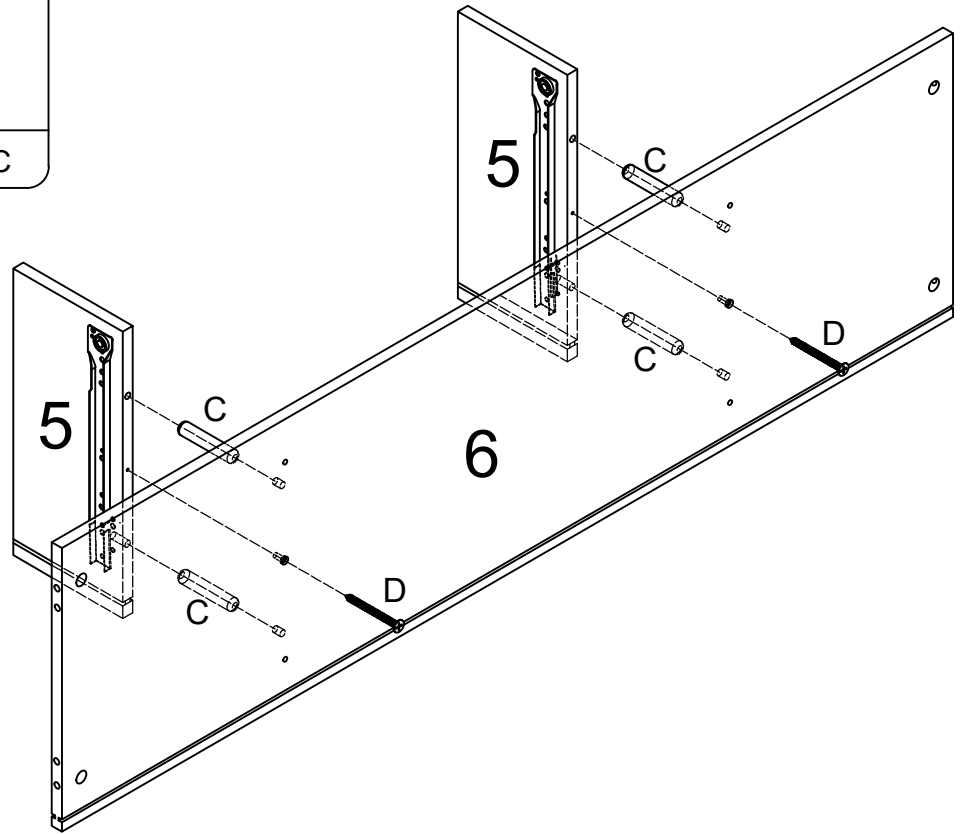
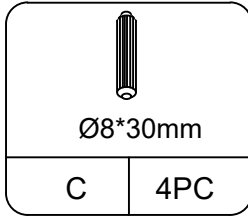
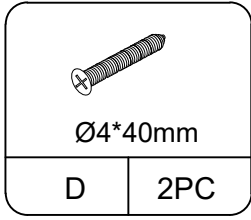

# STEP 3

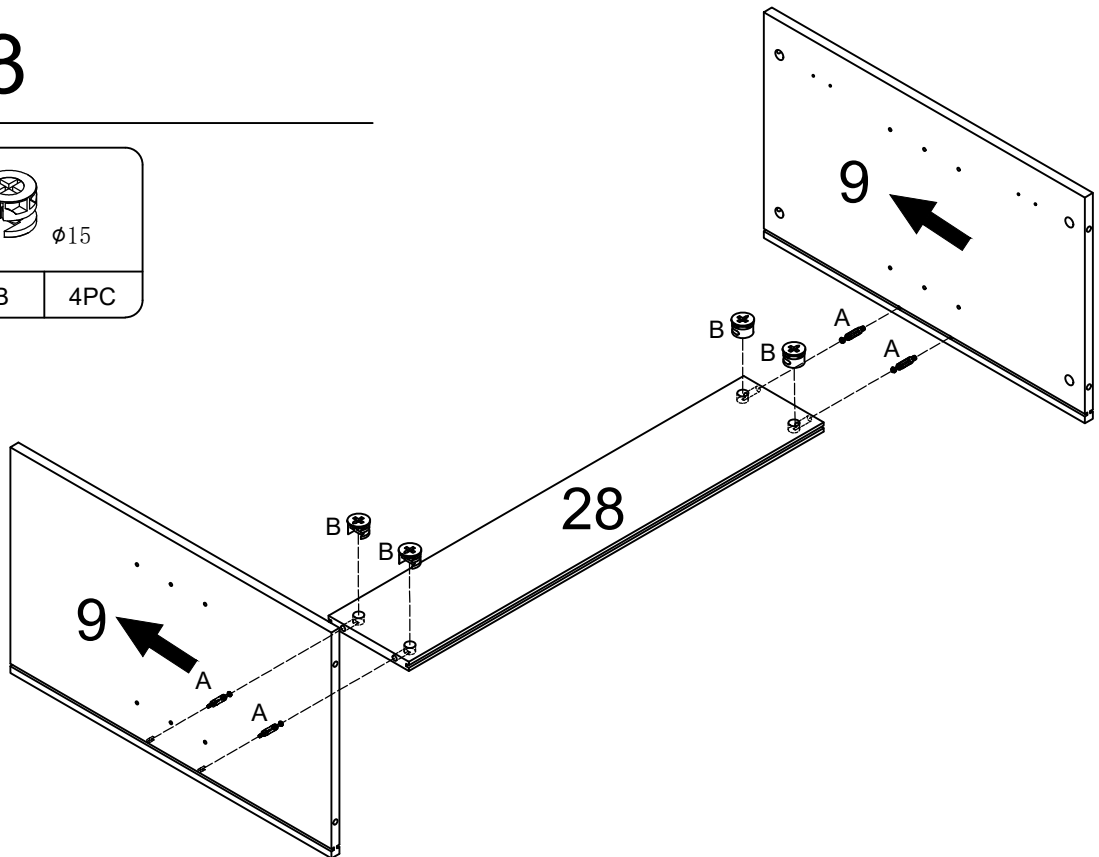
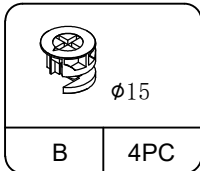
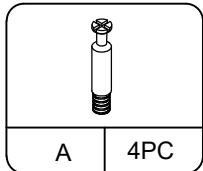

# STEP 4

---

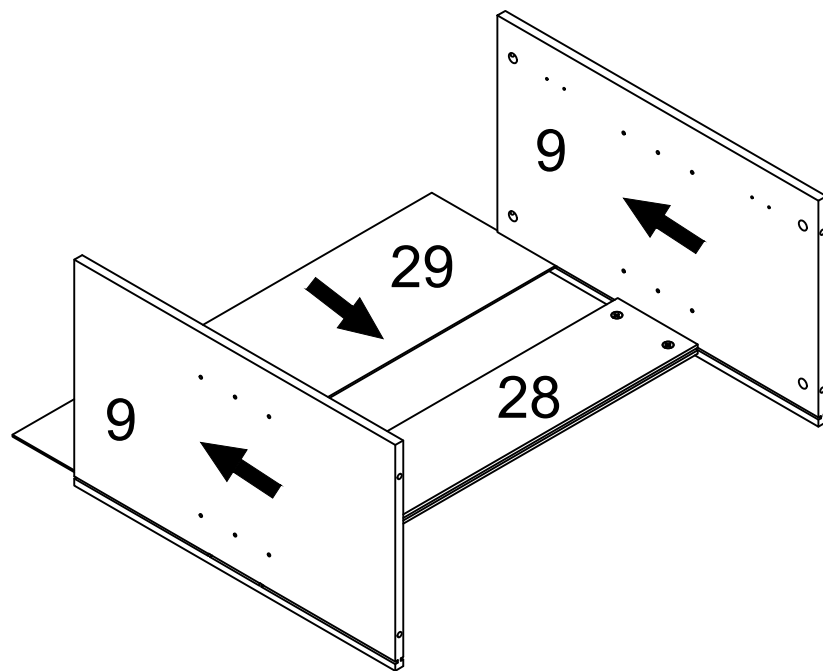

# STEP 5

---

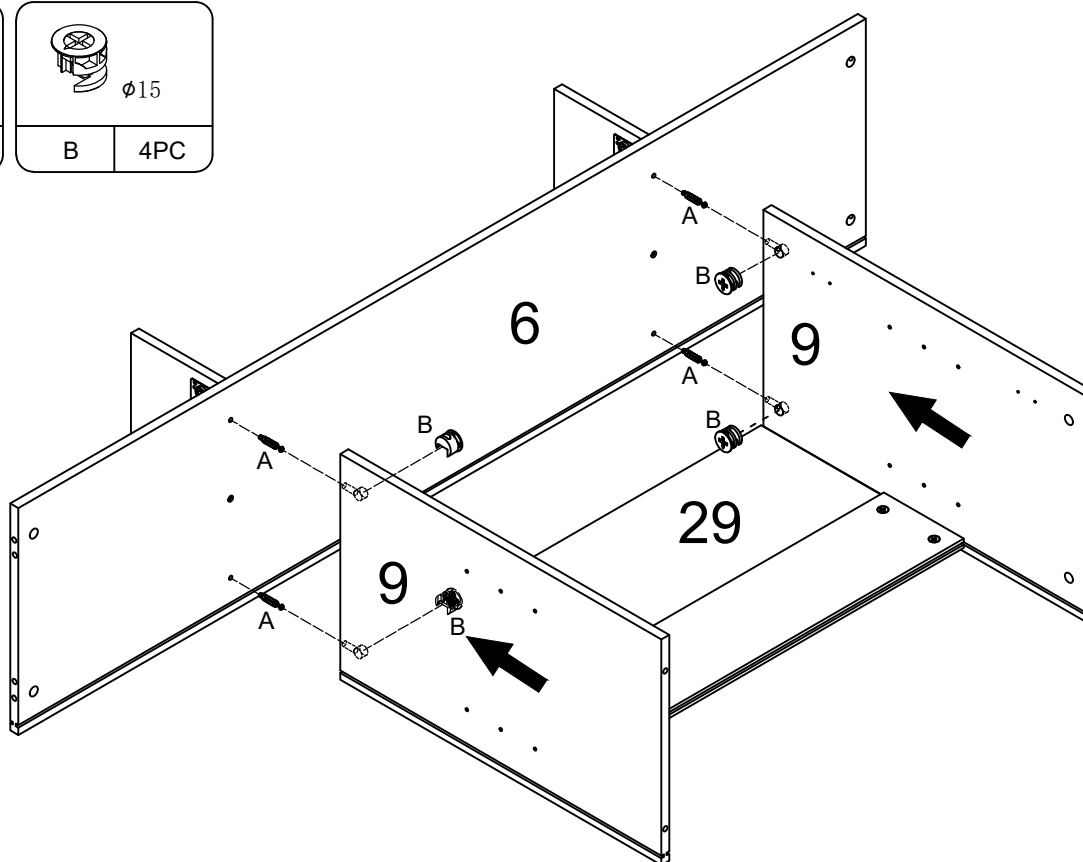
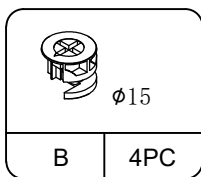
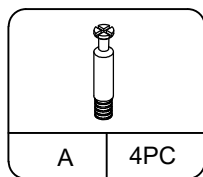

# STEP 6

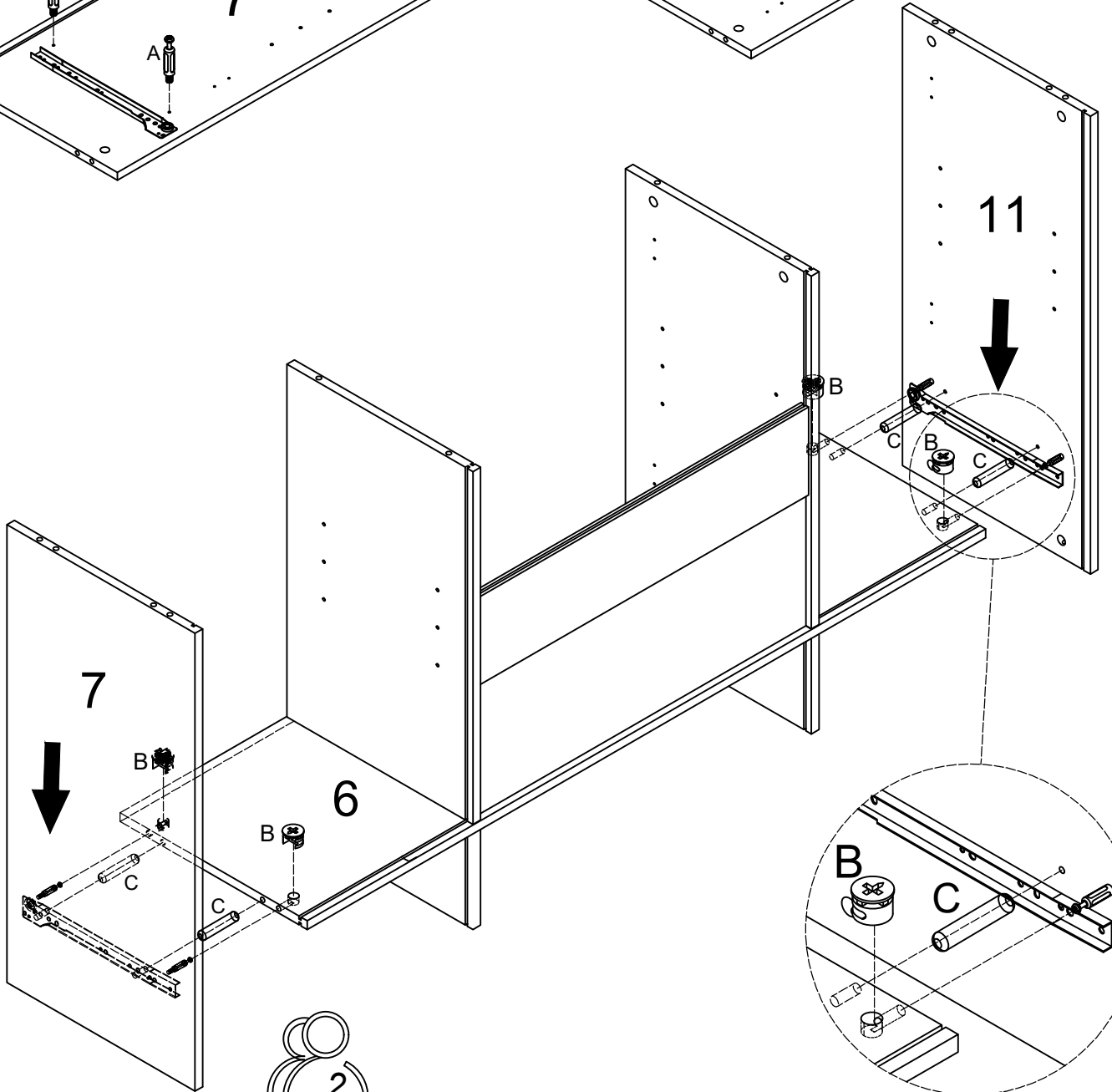
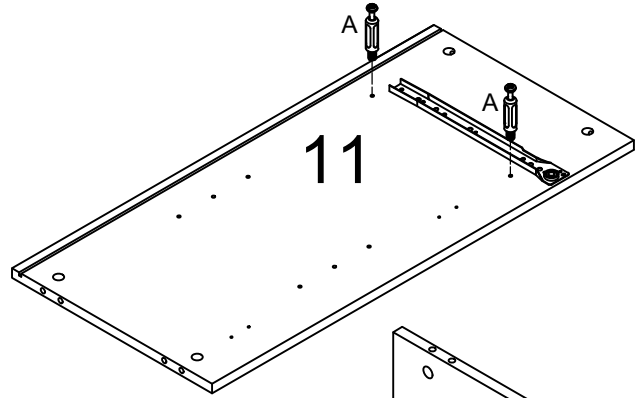
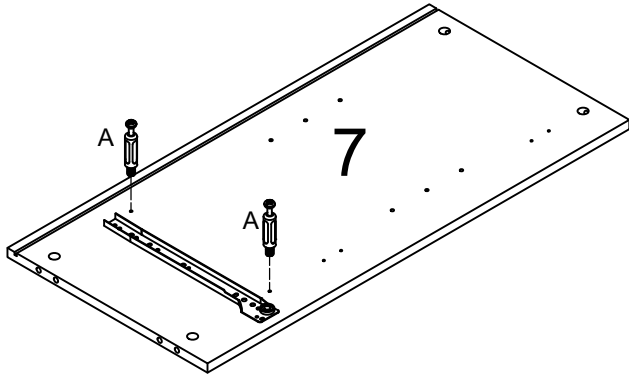
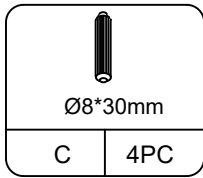
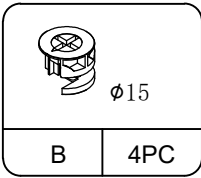
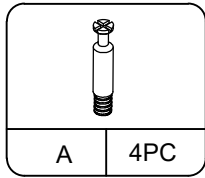

**Important**  
2 people required  
2 personnes requises  
2 personas requeridas

# STEP 7

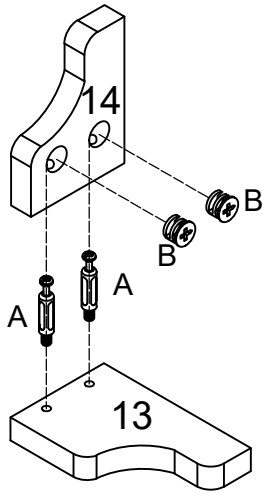
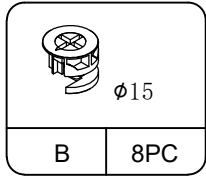
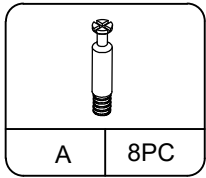

x2PCS

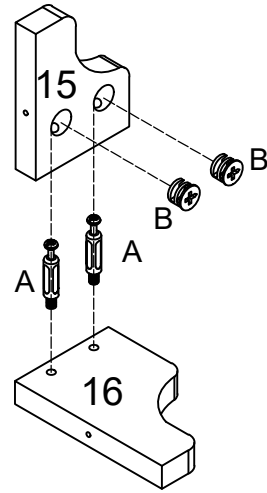

x2PCS

# STEP 8

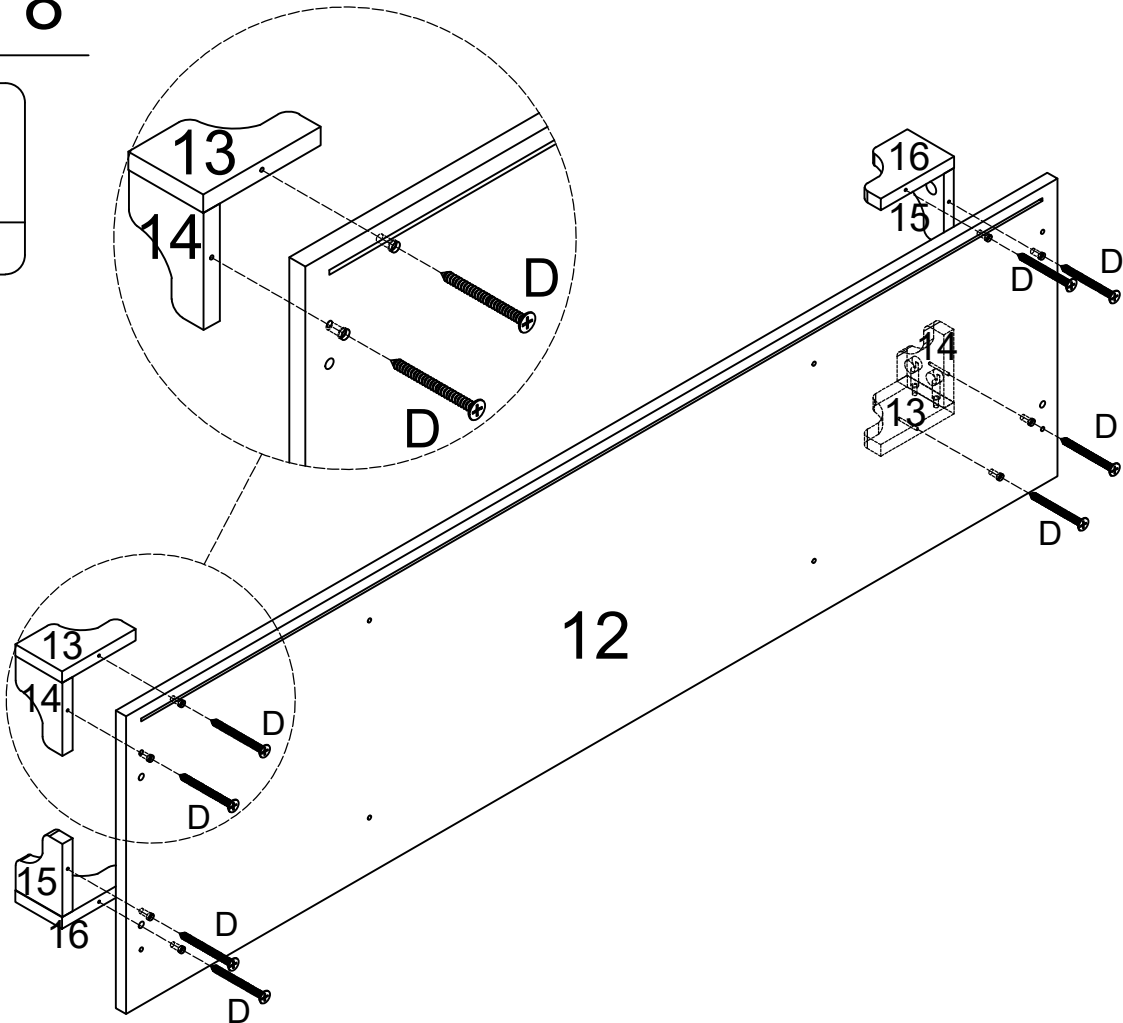
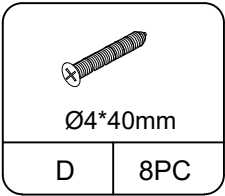

# STEP 9

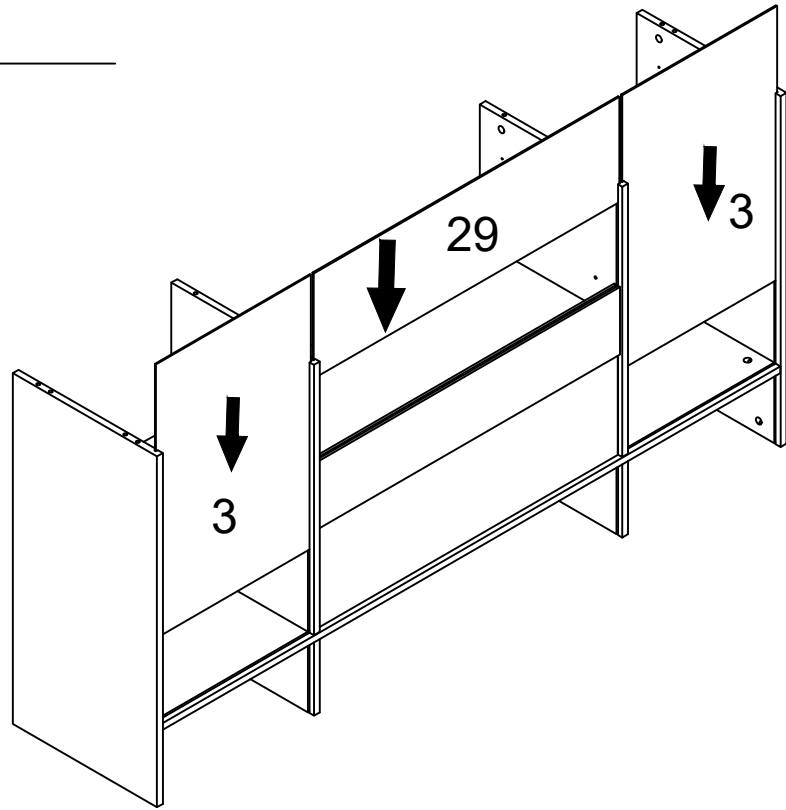

# STEP 10

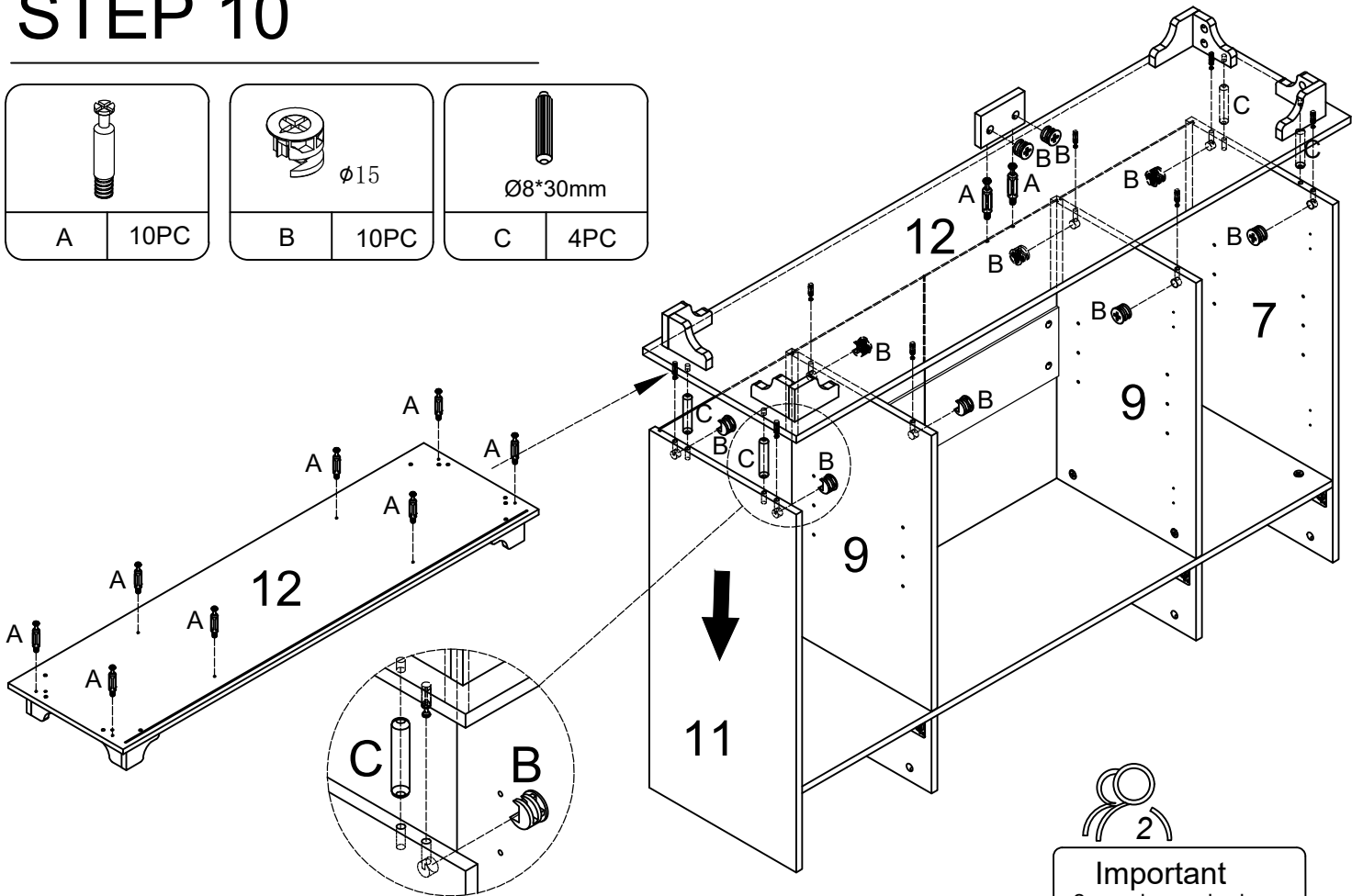
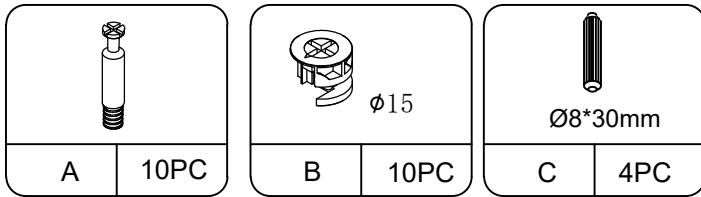

**Important**  
2 people required  
2 personnes requises  
2 personas requeridas

# STEP 11

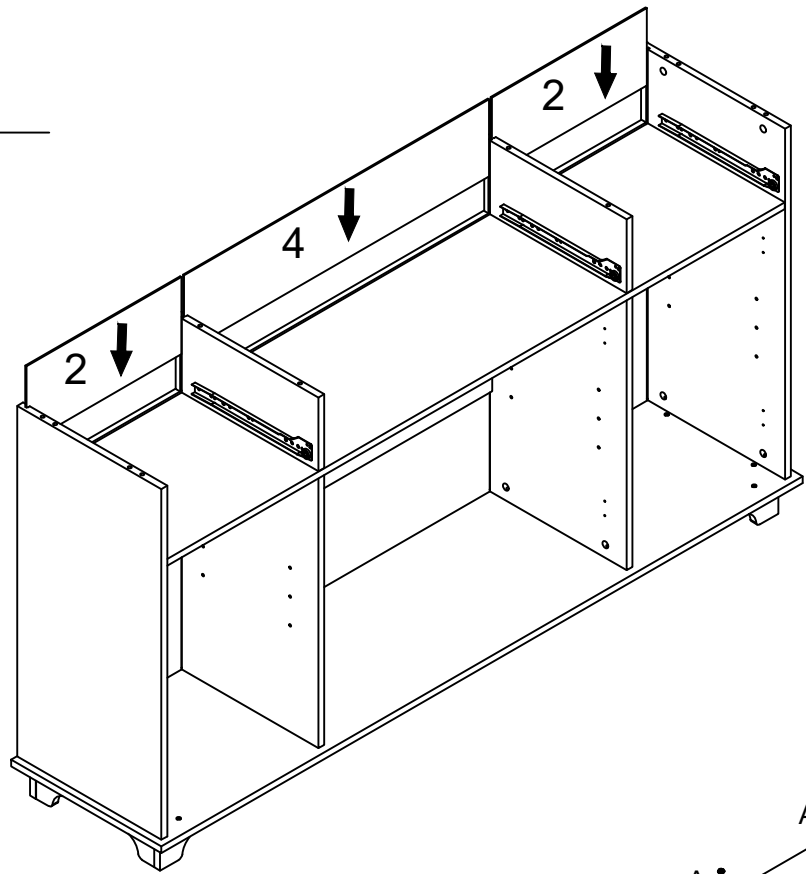

# STEP 12

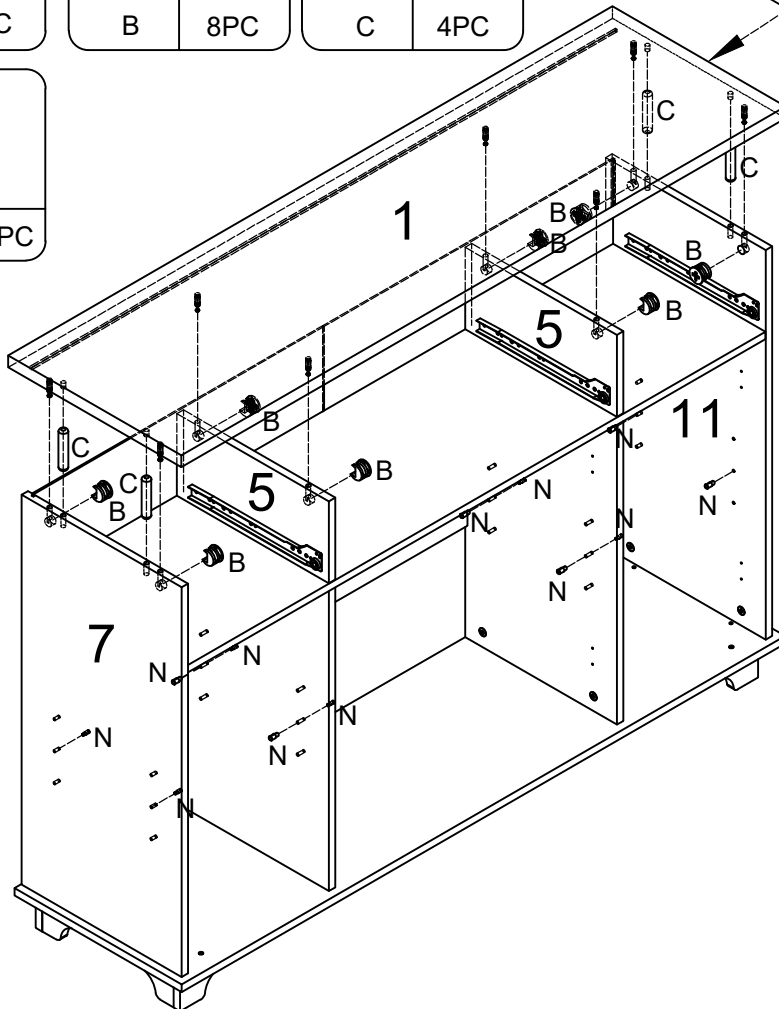
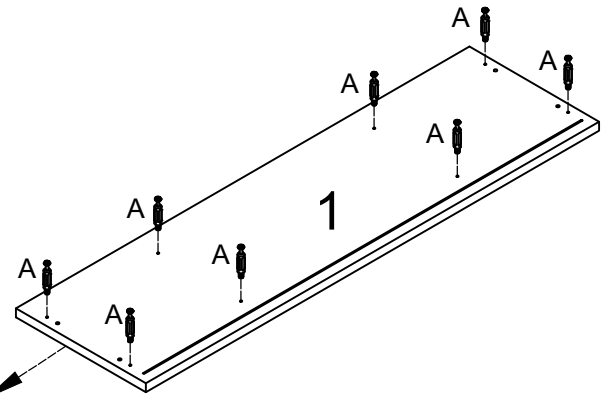
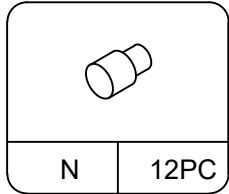
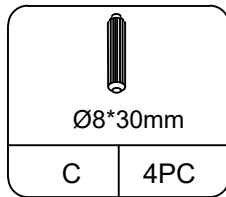
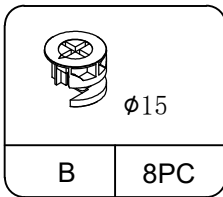
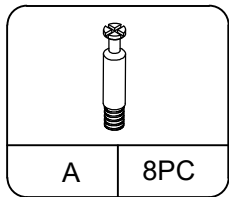

**Important**  
 2 people required  
 2 personas requiridas

# STEP 13

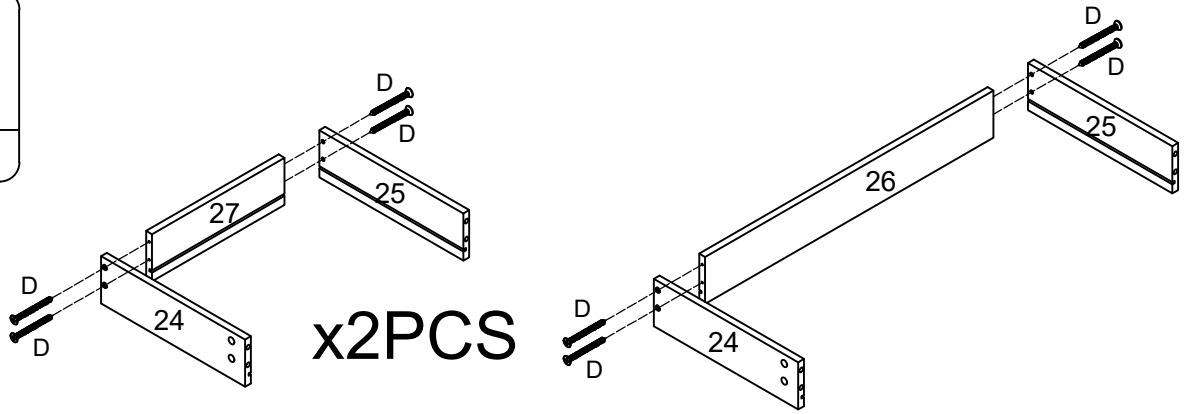
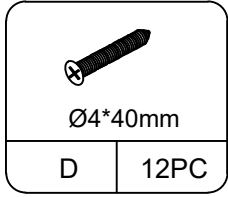

# STEP 14

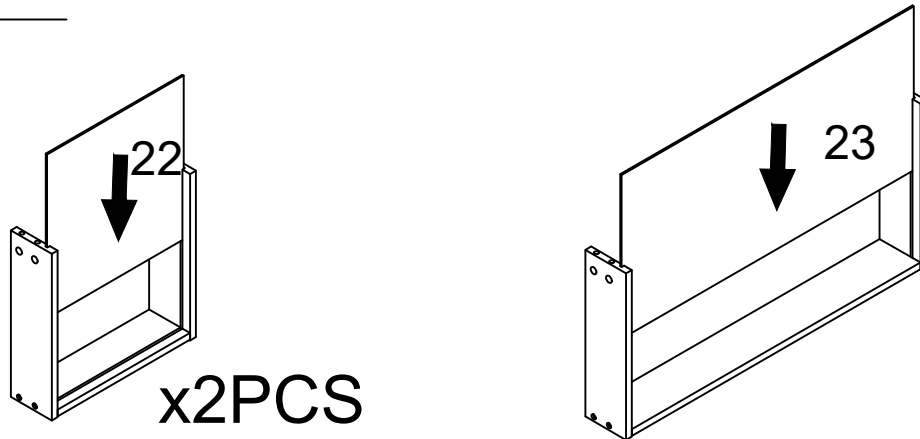

# STEP 15

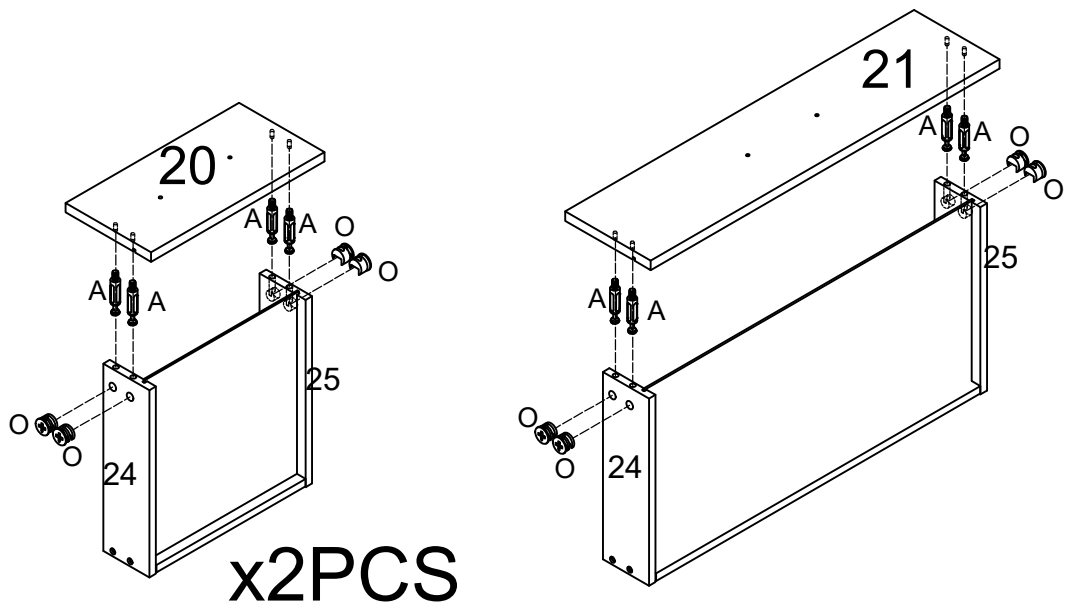
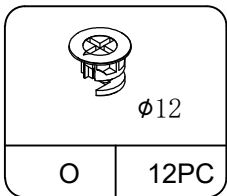
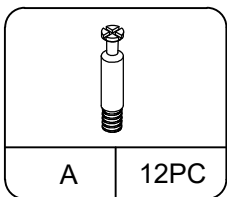

# STEP 16

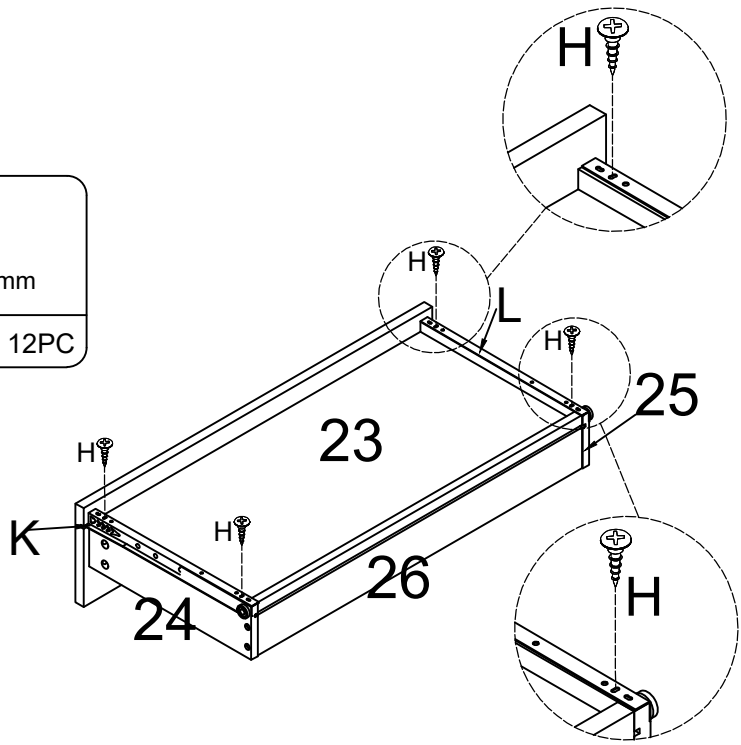
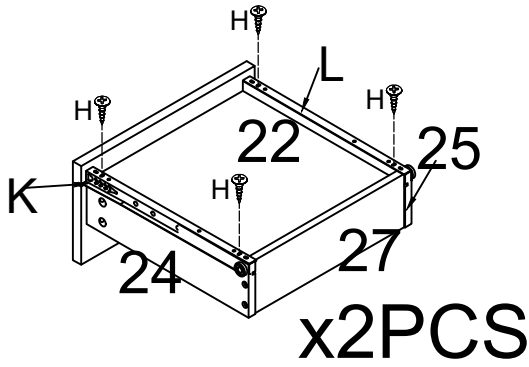
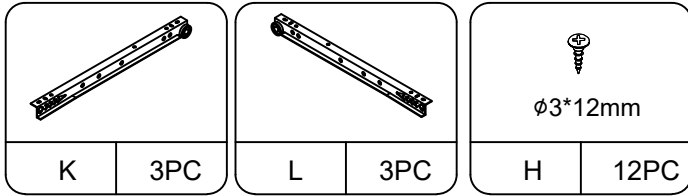

# STEP 17

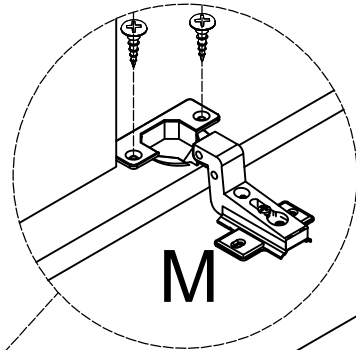
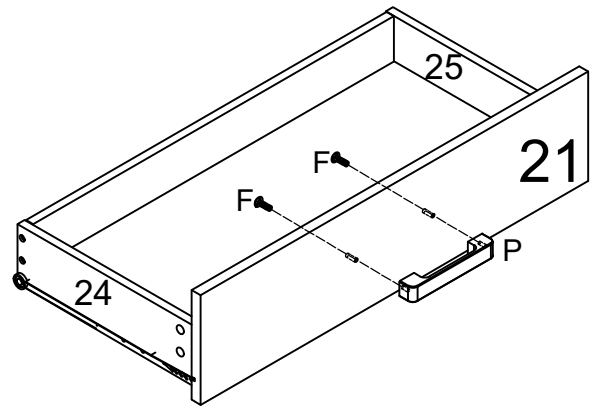
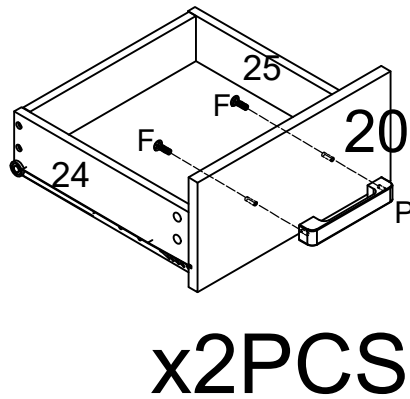
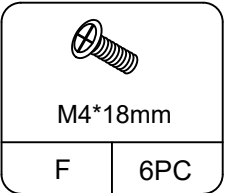
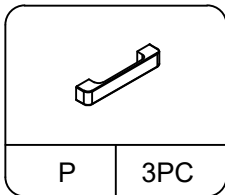

# STEP 18

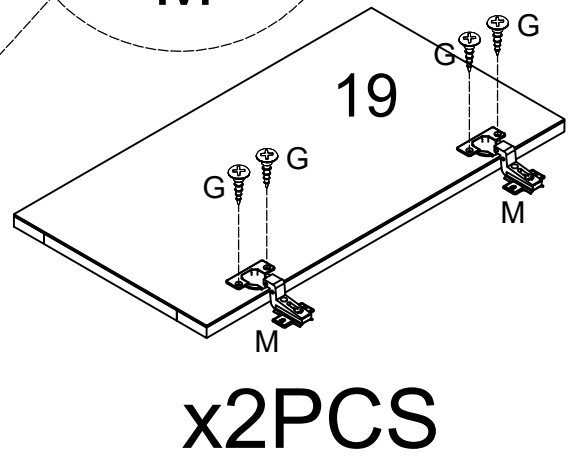
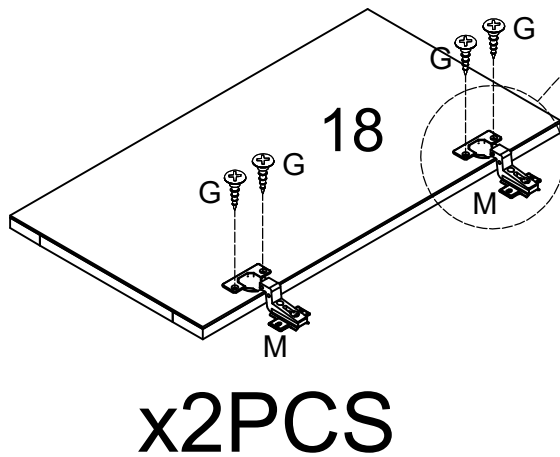
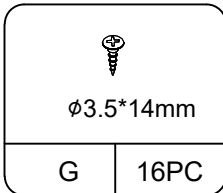
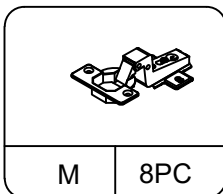

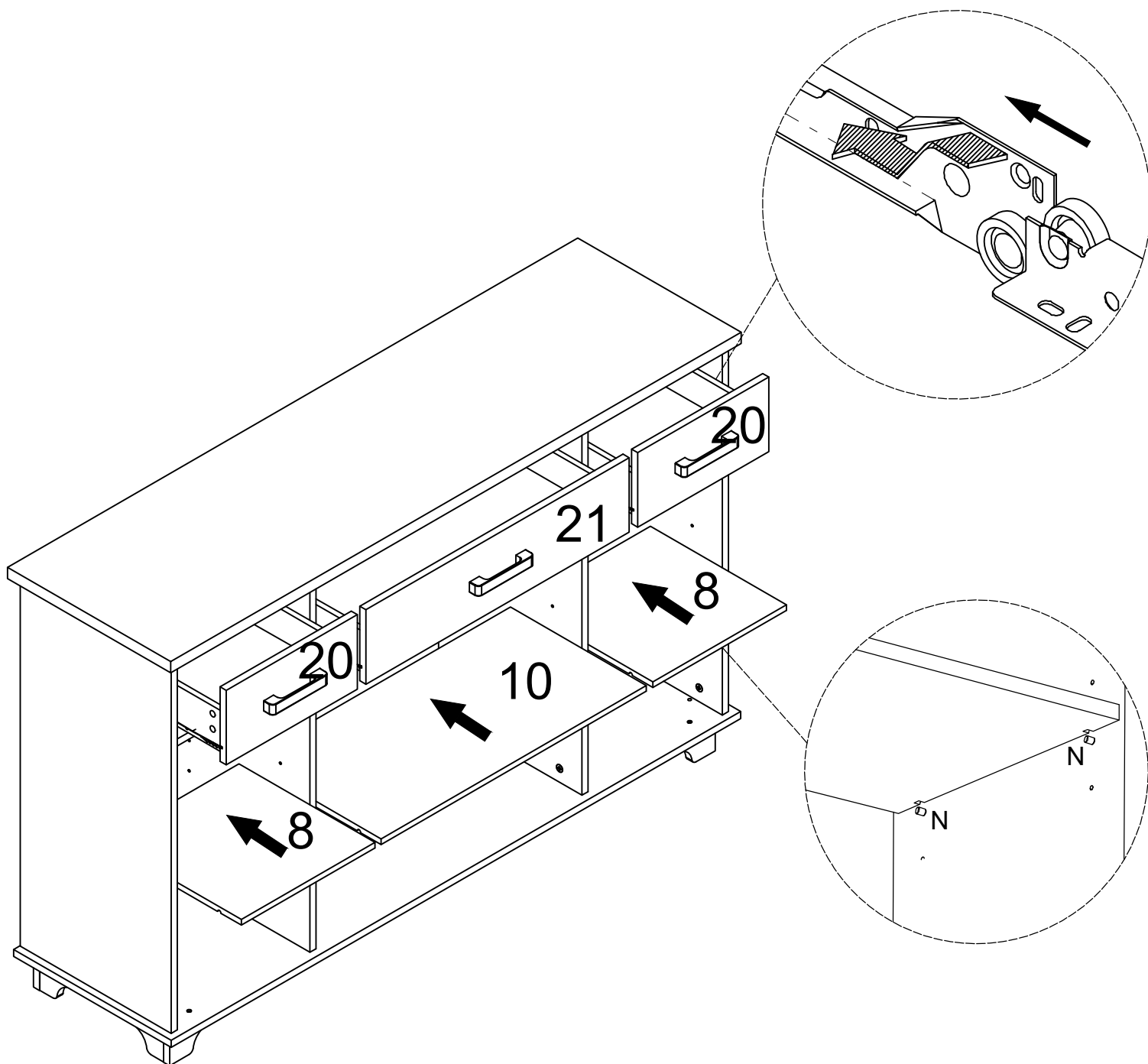

# STEP 19

---



# STEP 20

					
E		M4*22mm		ø3.5*14mm	
4PC		Q		4PC	
		G		16PC	

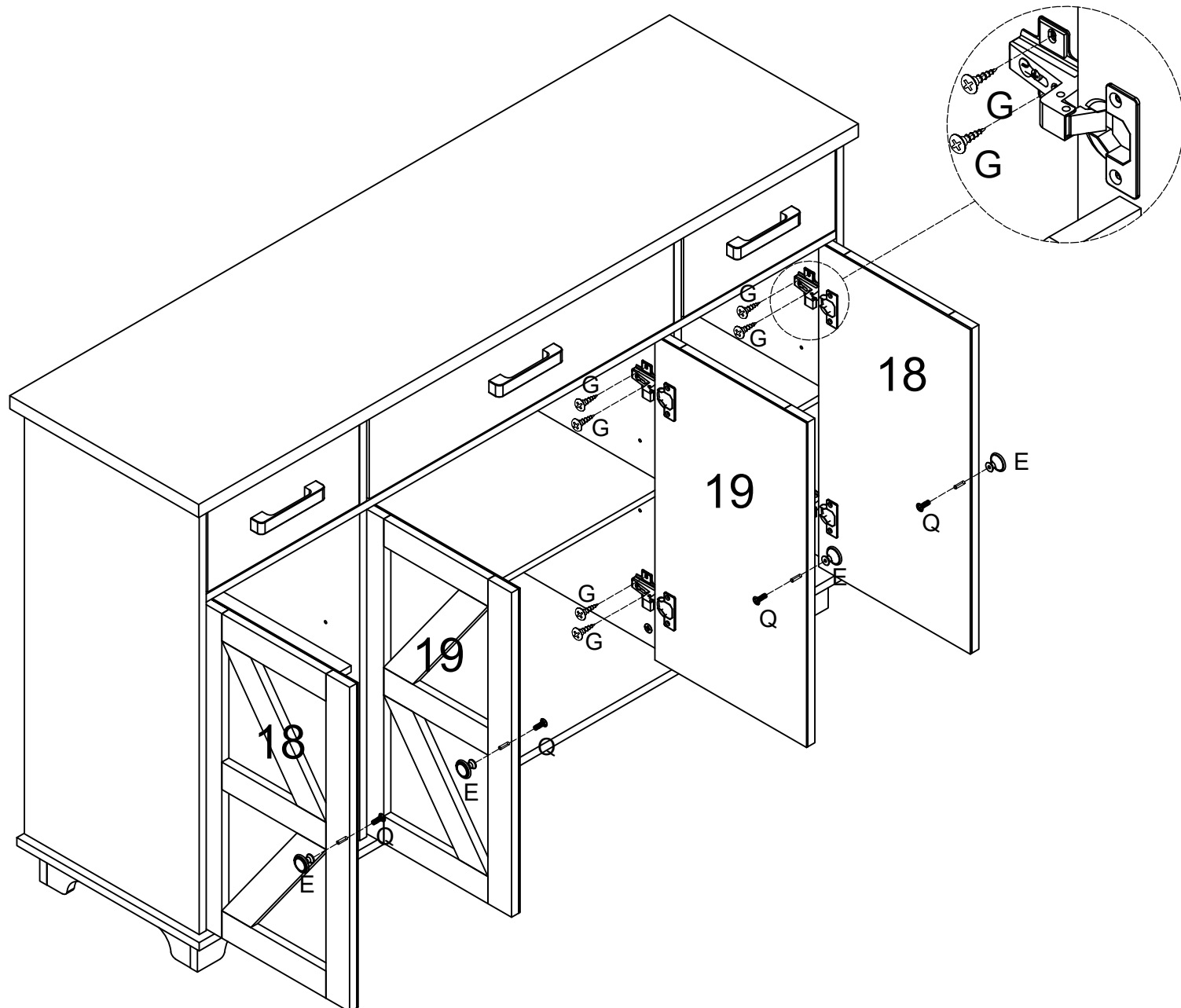

# STEP 21

---

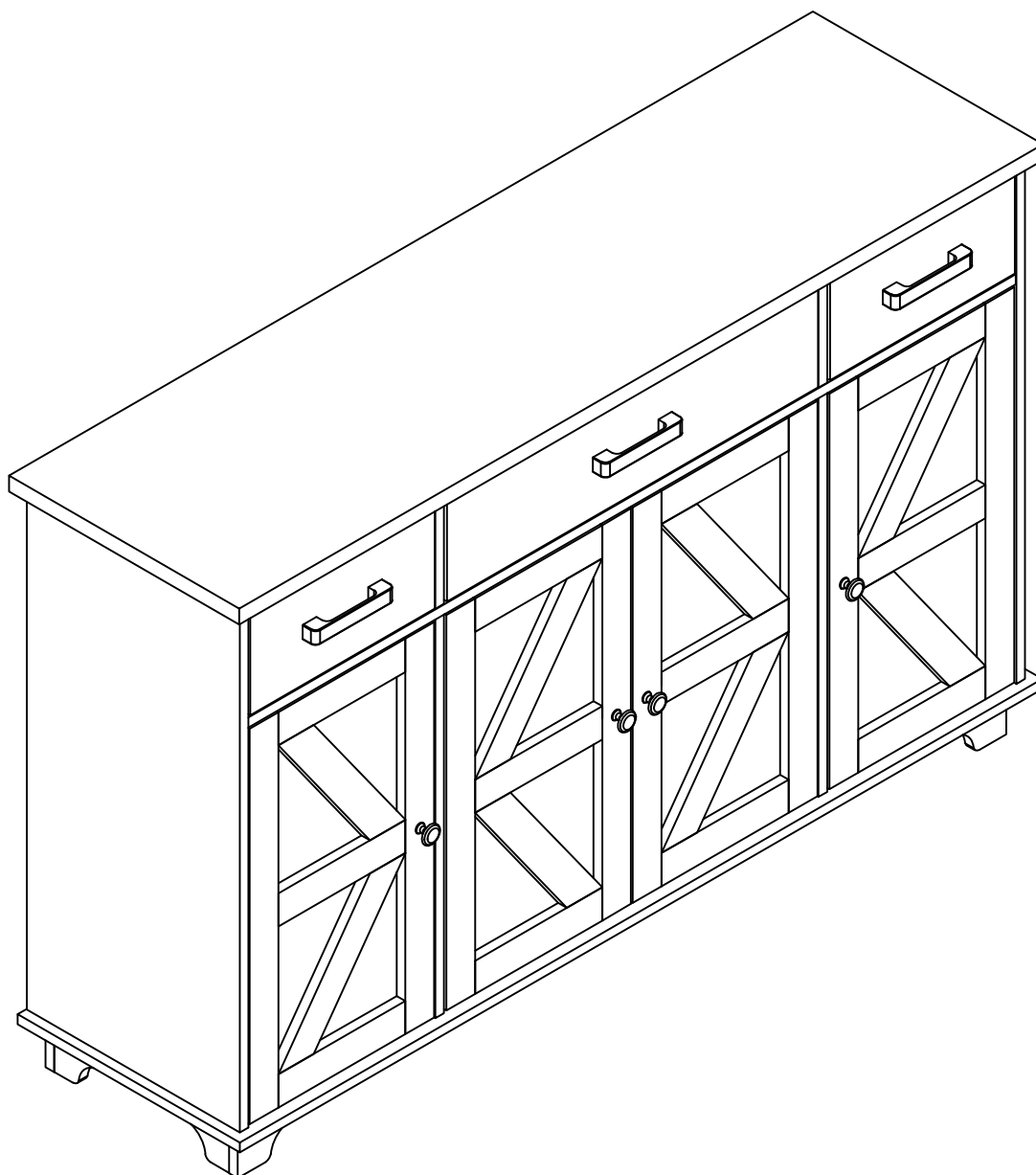

Please Make sure every screw is locked

# Door Hinge Adjustment Instructions

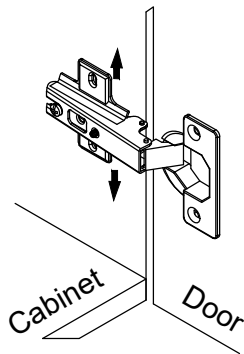
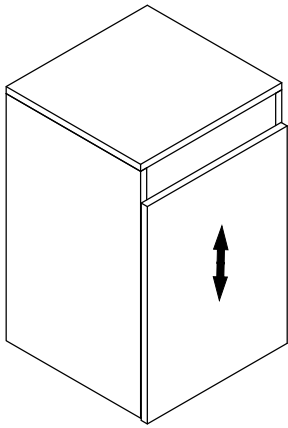
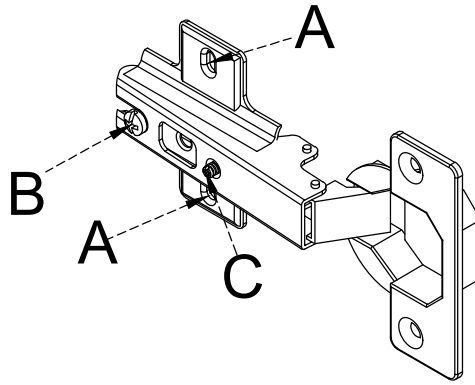

To adjust the vertical height.

Loosen the two screws "A" on hinges, Usually in slotted holes which allows you to adjust up or down by a few mm Then tighten back .

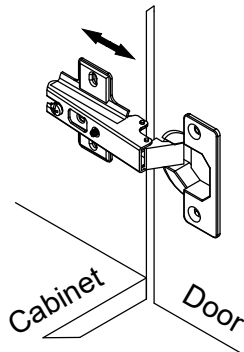
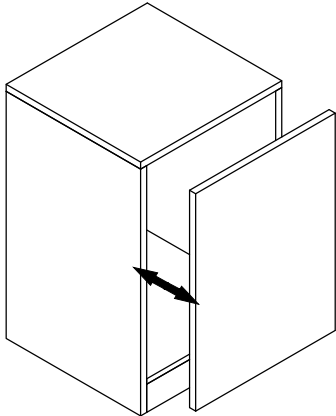

To adjust depth.

Loosen screw "B" and adjust door, if the door can not be adjusted, please loosen screw "C", then try again. Tighten screw "B" and "C"

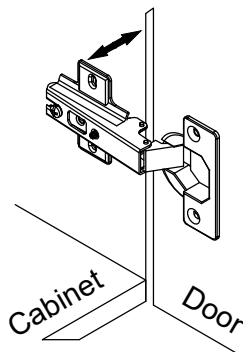
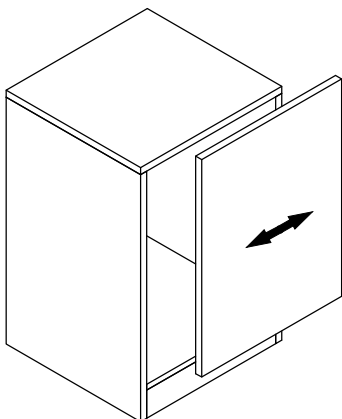

To adjust side ways.

Turning the screw "C" on BOTH hinges on each door.