

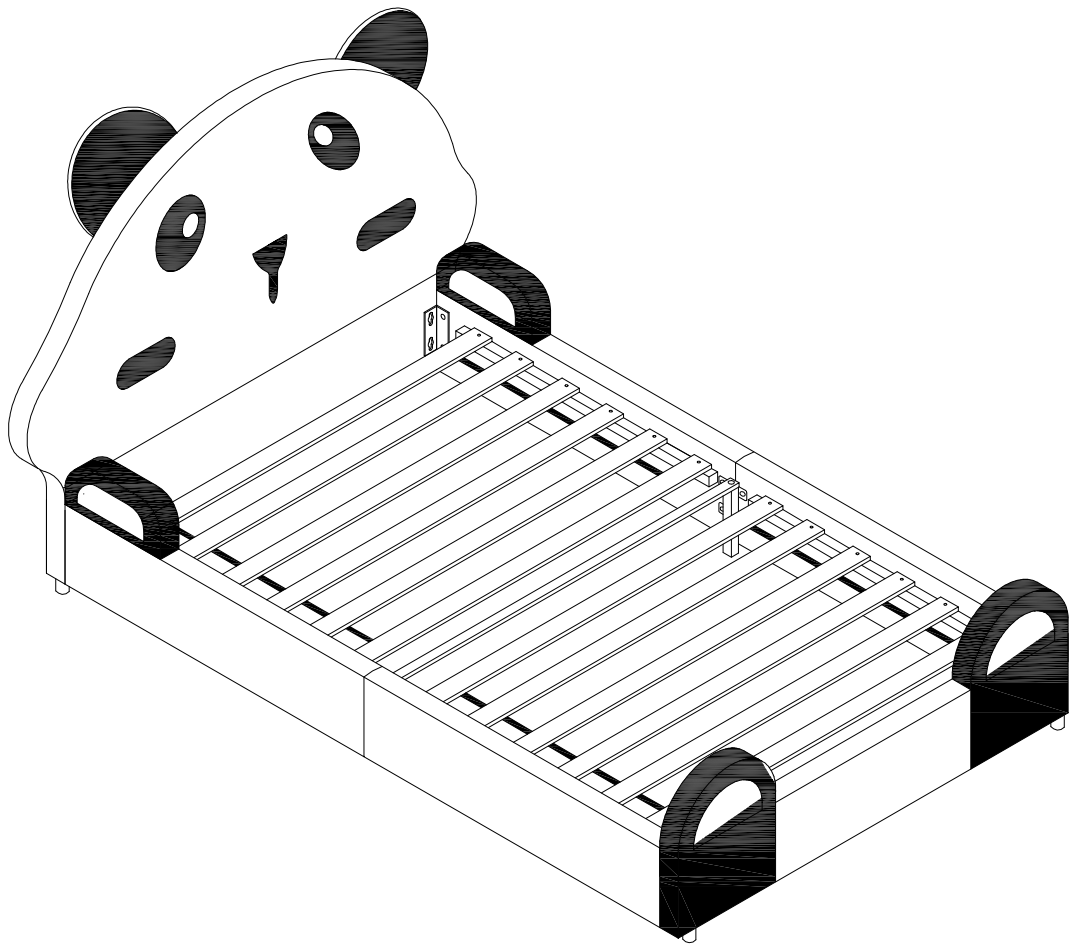

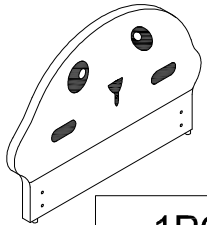

# ASSEMBLY INSTRUCTION

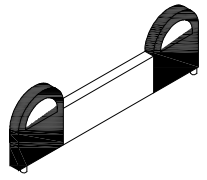

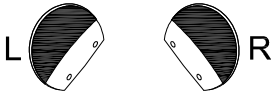

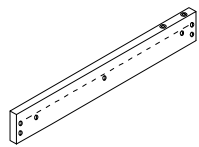
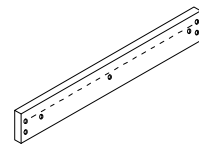
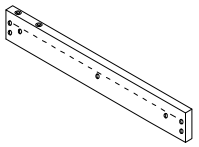
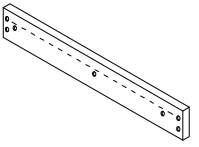
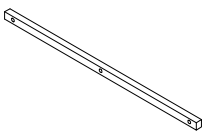
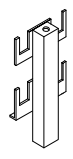
## 268T

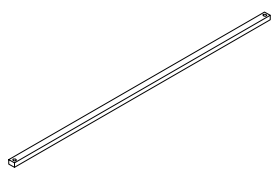
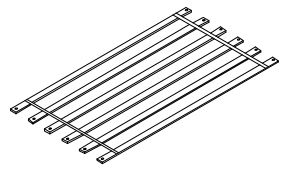

# PARTS LIST

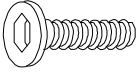
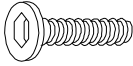
<p>① Headboard</p>  <p style="text-align: center;">1PC</p>	<p>② Footboard</p>  <p style="text-align: center;">1PC</p>	<p>③ HB</p>  <p style="text-align: center;">2PCS</p>	<p>④ SR</p>  <p style="text-align: center;">2PCS</p>
<p>⑤ HB Side Rail -L</p>  <p style="text-align: center;">1PC</p>	<p>⑥ FB Side Rail -L</p>  <p style="text-align: center;">1PC</p>	<p>⑦ HB Side Rail -R</p>  <p style="text-align: center;">1PC</p>	<p>⑧ FB Side Rail -R</p>  <p style="text-align: center;">1PC</p>
<p>⑨ Side rail support</p>  <p style="text-align: center;">4PCS</p>	<p>⑩ Side rail feet</p>  <p style="text-align: center;">2PCS</p>	<p>⑪ Iron Plate</p>  <p style="text-align: center;">4PCS</p>	<p>⑫ Bed Leg</p>  <p style="text-align: center;">4PCS</p>
<p>⑬ Center cross bar</p>  <p style="text-align: center;">1PC</p>	<p>⑭ Slat</p>  <p style="text-align: center;">2SET</p>		

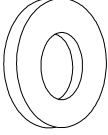
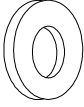
# HARDWARE LIST

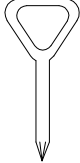
<p><b>A Screw</b></p>  <div style="text-align: right; margin-top: 10px;"> <span style="border: 1px solid black; padding: 2px;">4PCS</span> </div>	<p><b>B Screw</b></p>  <div style="text-align: right; margin-top: 10px;"> <span style="border: 1px solid black; padding: 2px;">m8*30mm</span> <span style="border: 1px solid black; padding: 2px; margin-left: 10px;">26PCS</span> </div>	<p><b>C Screw</b></p>  <div style="text-align: right; margin-top: 10px;"> <span style="border: 1px solid black; padding: 2px;">m6*45mm</span> <span style="border: 1px solid black; padding: 2px; margin-left: 10px;">16PCS</span> </div>	<p><b>D Screw</b></p>  <div style="text-align: right; margin-top: 10px;"> <span style="border: 1px solid black; padding: 2px;">M4*30mm</span> <span style="border: 1px solid black; padding: 2px; margin-left: 10px;">24PCS</span> </div>
<p><b>E Lock Washer</b></p>  <div style="text-align: right; margin-top: 10px;"> <span style="border: 1px solid black; padding: 2px;">m8*13mm</span> <span style="border: 1px solid black; padding: 2px; margin-left: 10px;">26PCS</span> </div>	<p><b>F Flat Washer</b></p>  <div style="text-align: right; margin-top: 10px;"> <span style="border: 1px solid black; padding: 2px;">m8**19mm</span> <span style="border: 1px solid black; padding: 2px; margin-left: 10px;">26PCS</span> </div>	<p><b>G Flat Washer</b></p>  <div style="text-align: right; margin-top: 10px;"> <span style="border: 1px solid black; padding: 2px;">m6*16mm</span> <span style="border: 1px solid black; padding: 2px; margin-left: 10px;">16PCS</span> </div>	<p><b>H Inner allen wrench</b></p>  <div style="text-align: right; margin-top: 10px;"> <span style="border: 1px solid black; padding: 2px;">M8</span> <span style="border: 1px solid black; padding: 2px; margin-left: 10px;">1PC</span> </div>
<p><b>I Inner allen wrench</b></p>  <div style="text-align: right; margin-top: 10px;"> <span style="border: 1px solid black; padding: 2px;">M6</span> <span style="border: 1px solid black; padding: 2px; margin-left: 10px;">1PC</span> </div>	<p><b>J Screwdriver</b></p>  <div style="text-align: right; margin-top: 10px;"> <span style="border: 1px solid black; padding: 2px;">M8</span> <span style="border: 1px solid black; padding: 2px; margin-left: 10px;">1PC</span> </div>		

## STEP :Packing Details

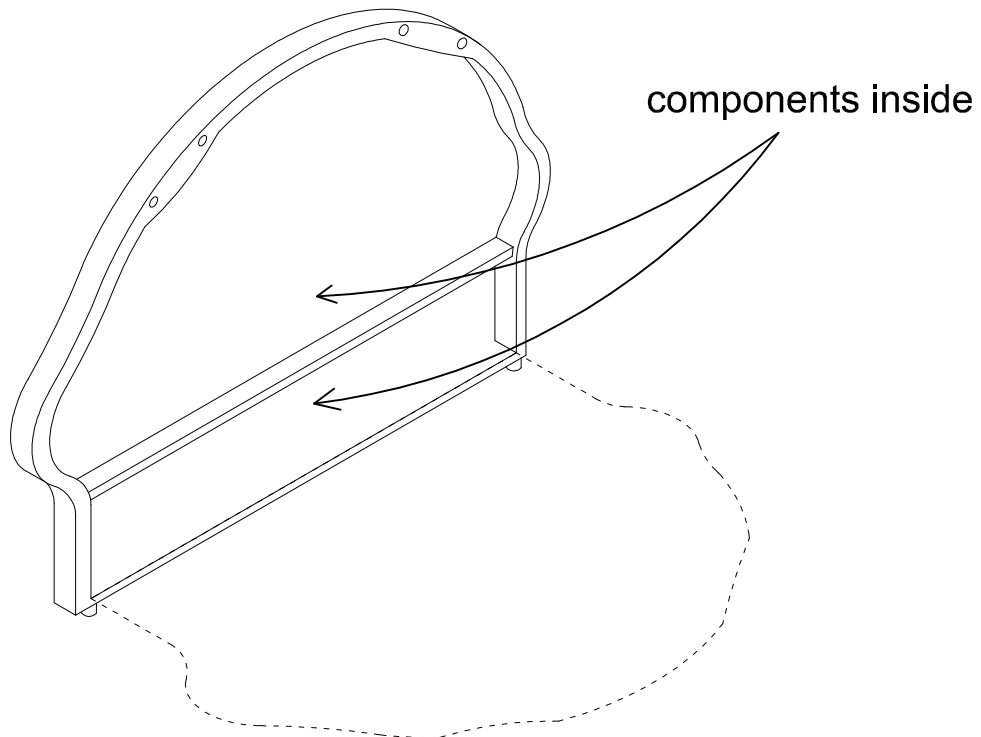

# Assembly Steps

## STEP 1:

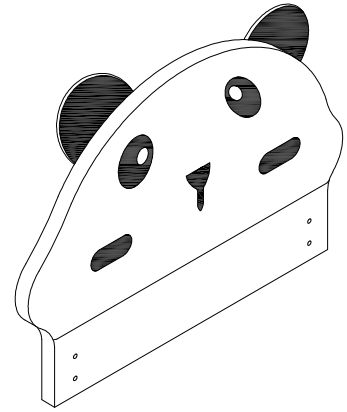
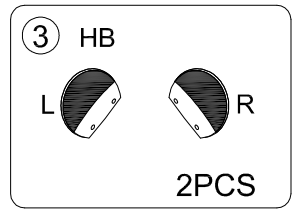
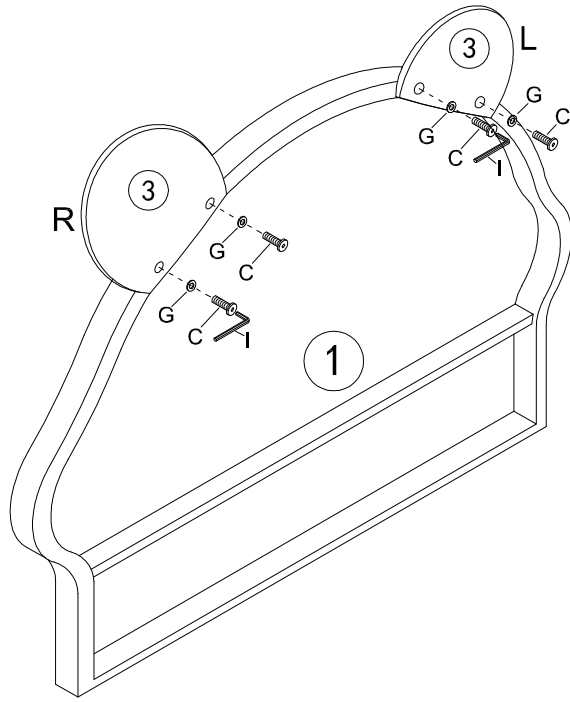

	C x4PCS
	I x 1PC
	G x4PCS

## STEP 2:

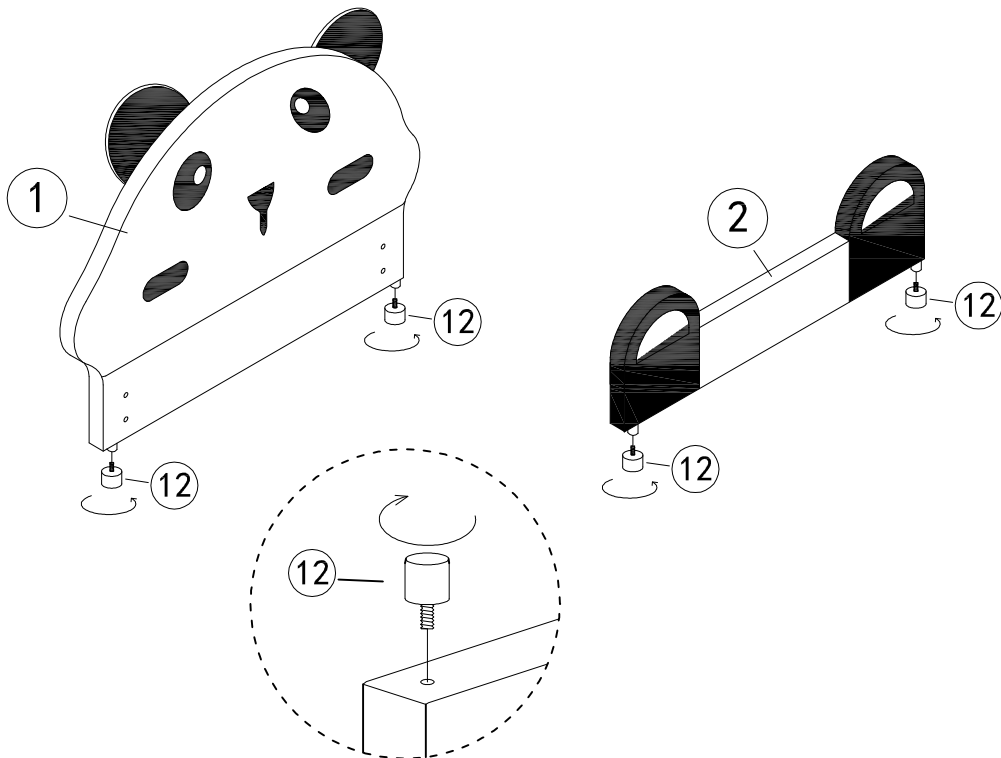



12x4PCS

# Assembly Steps

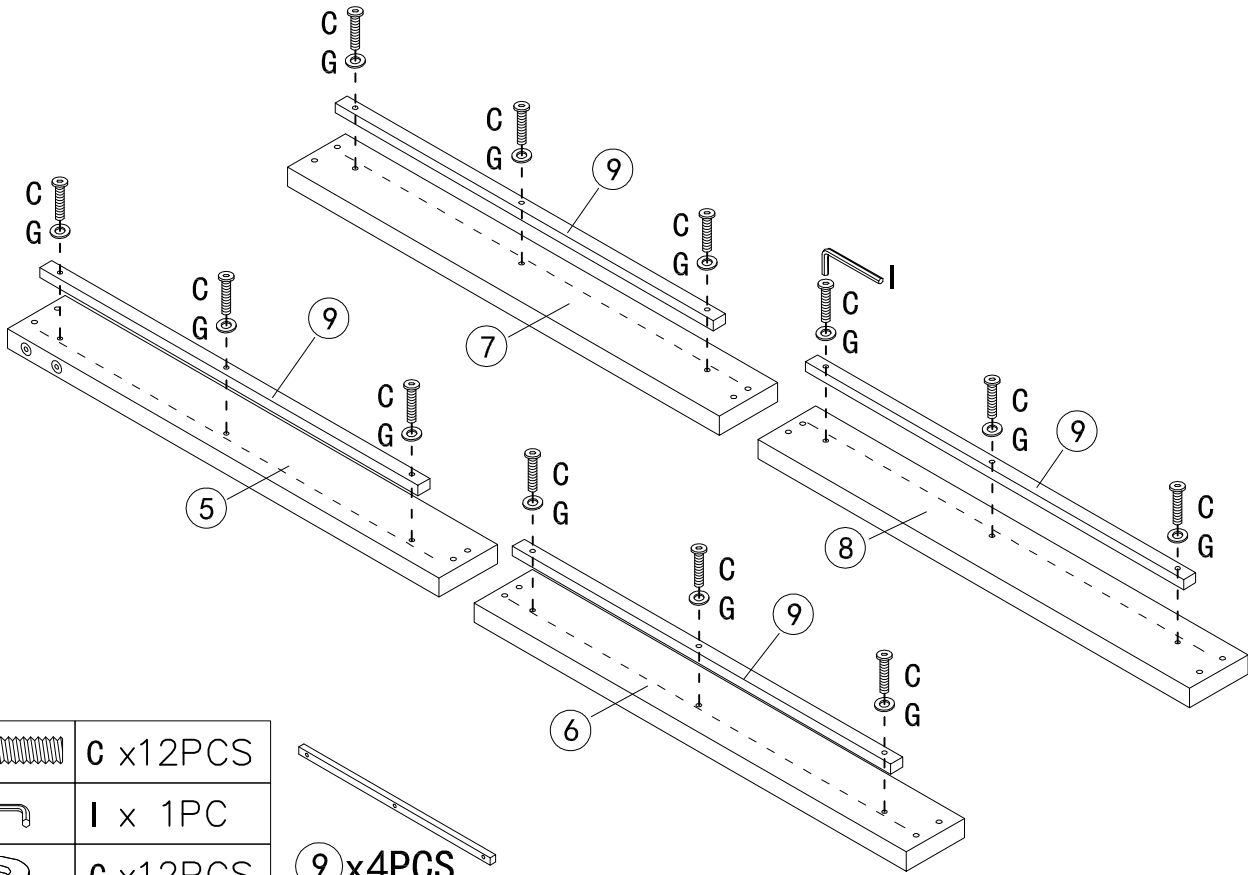
## STEP 3:





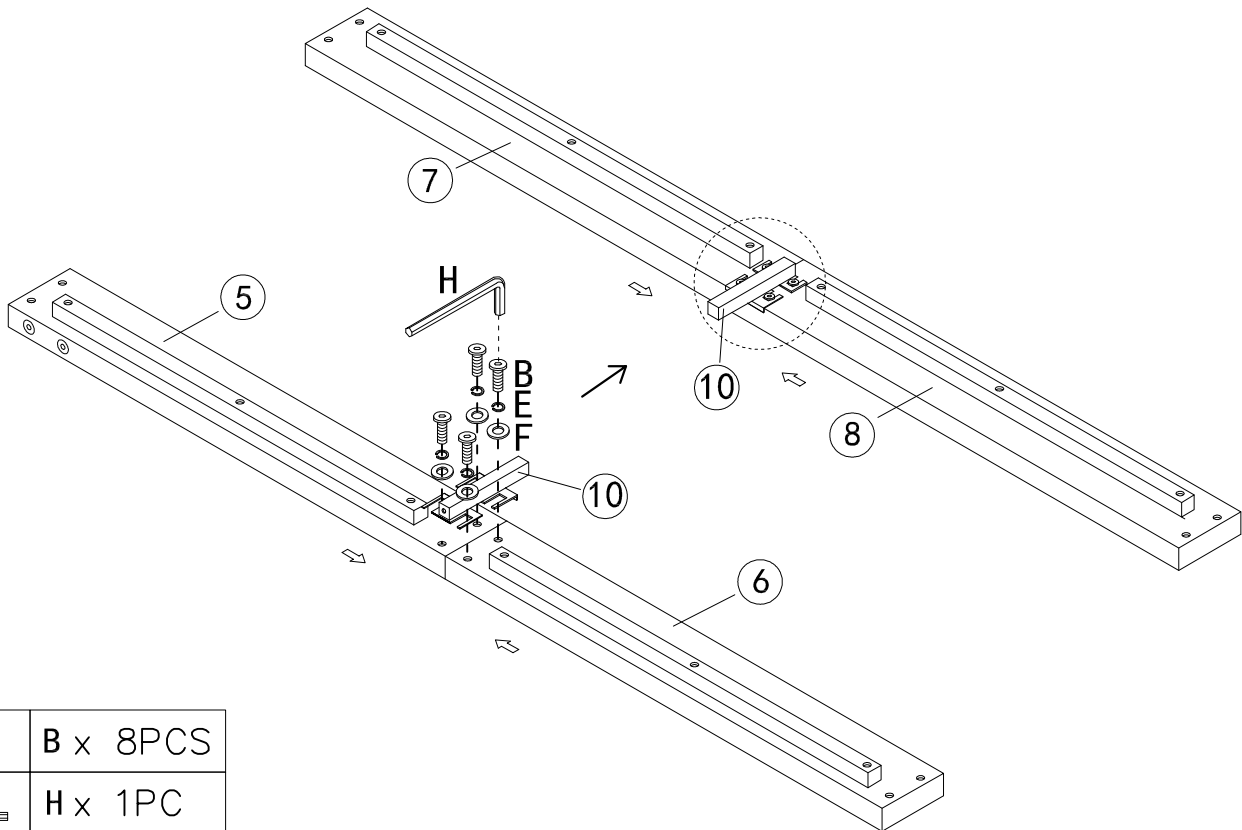

	C x12PCS
	I x 1PC
	G x12PCS

 9 x4PCS

## STEP 4:





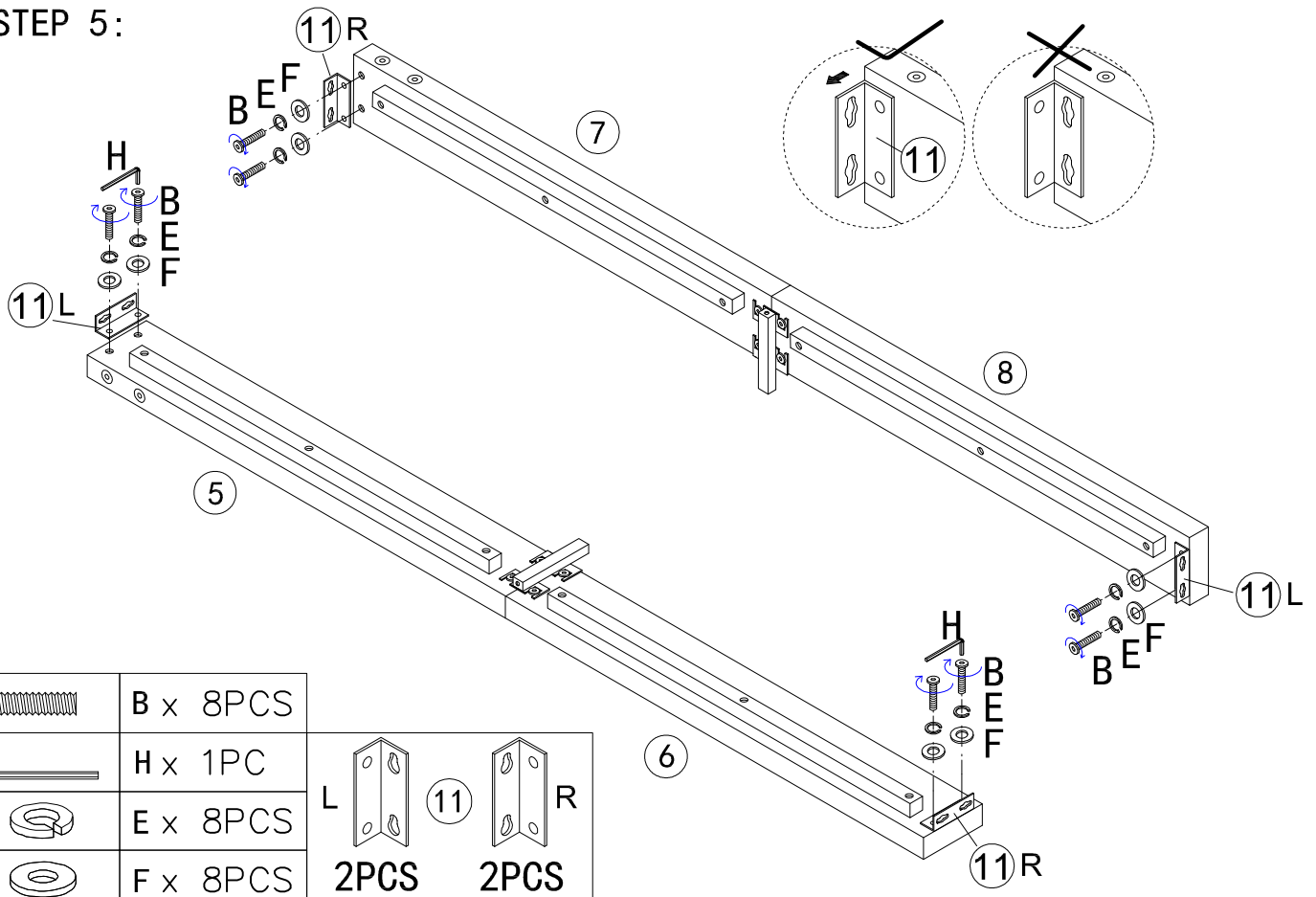

	B x 8PCS
	H x 1PC
	E x 8PCS
	F x 8PCS

# Assembly Steps

STEP 5:





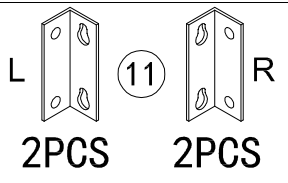

	B x 8PCS
	H x 1PC
	E x 8PCS
	F x 8PCS

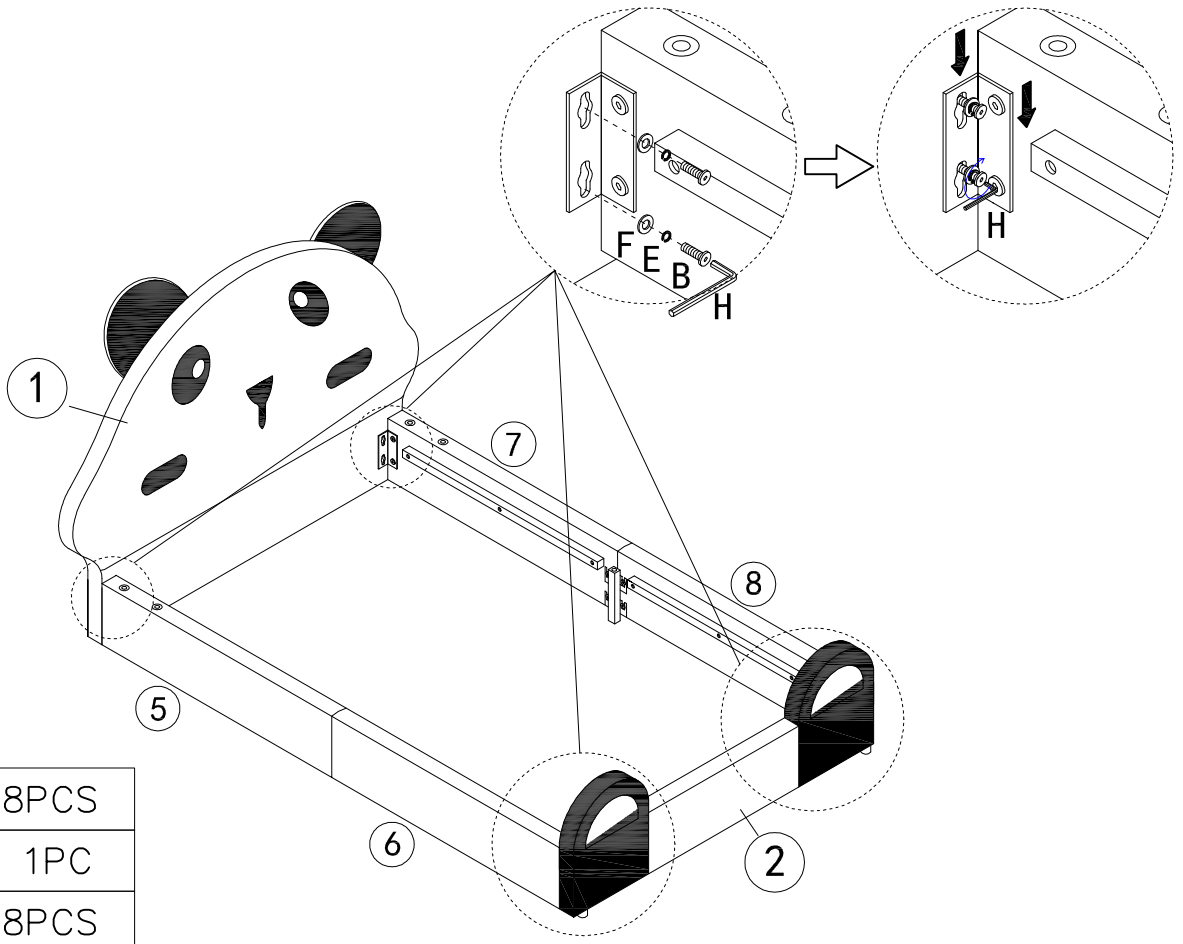

STEP 6:





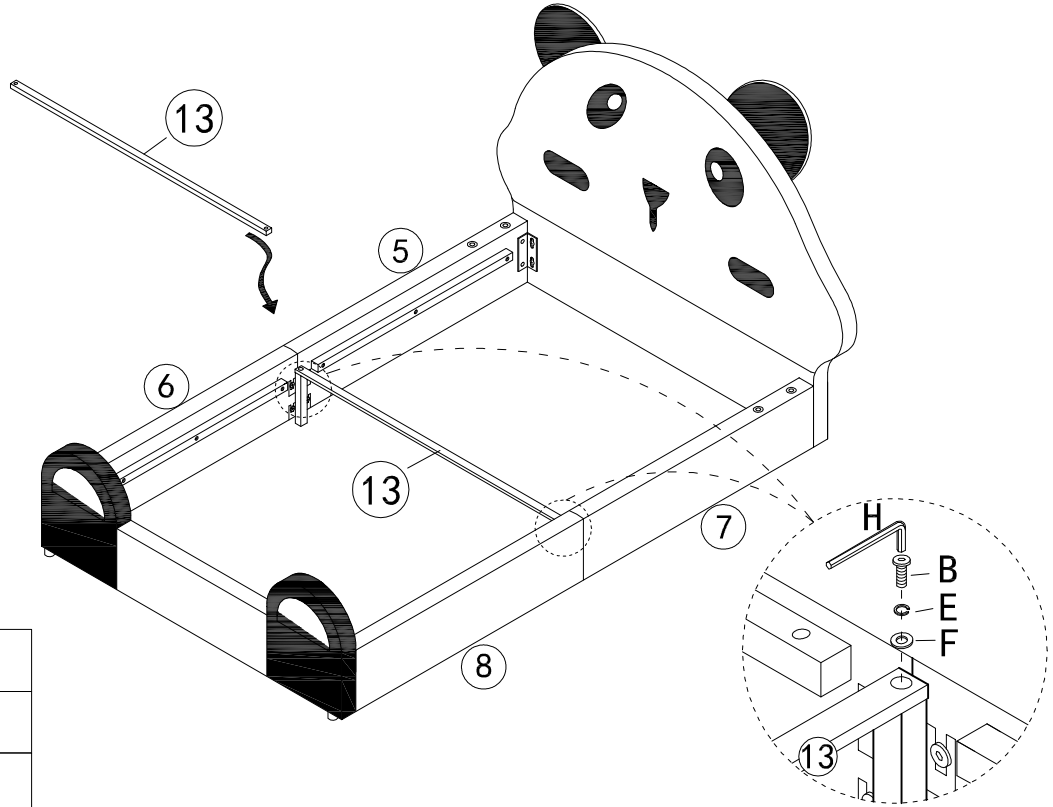

	B x8PCS
	H x 1PC
	E x8PCS
	F x8PCS

# Assembly Steps

## STEP 7:



	B x2PCS
	H x 1PC
	E x2PCS
	F x2PCS

## STEP 8:

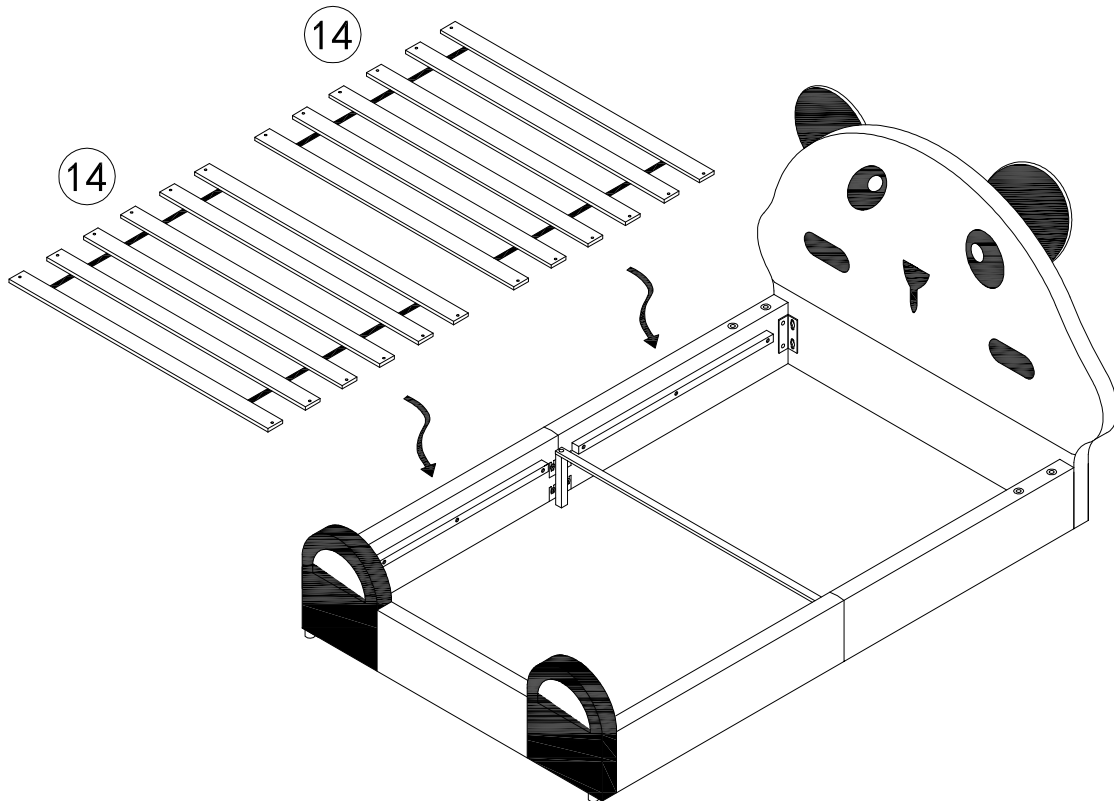

# Assembly Steps

STEP 9:

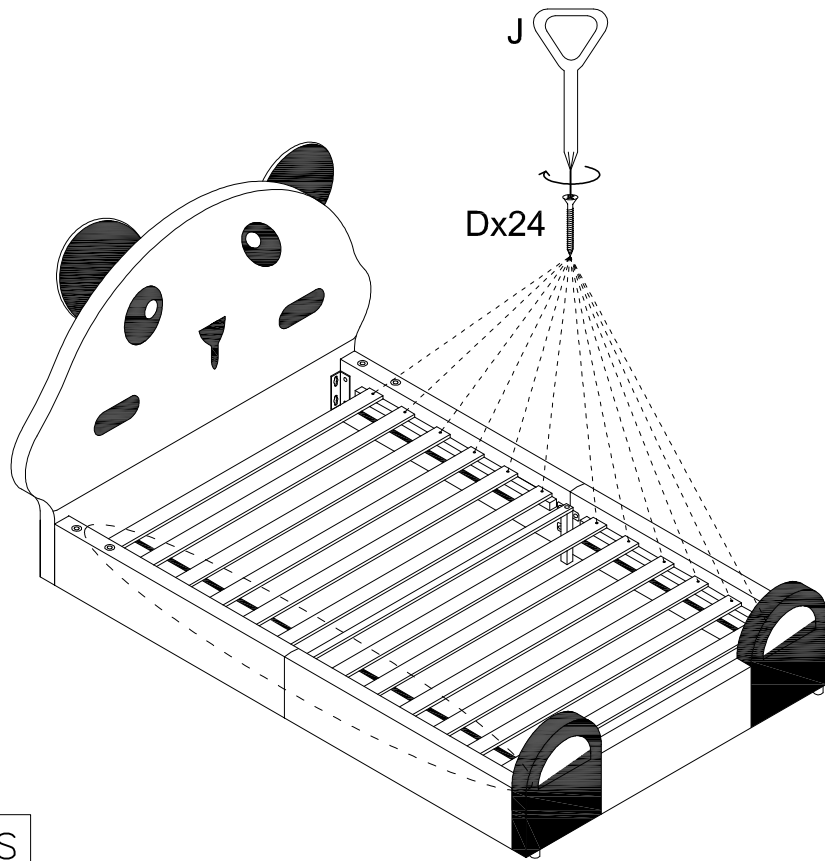

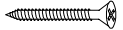
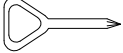
	D x24PCS
	J x1PC

STEP 10:

**A** Screw



4PCS

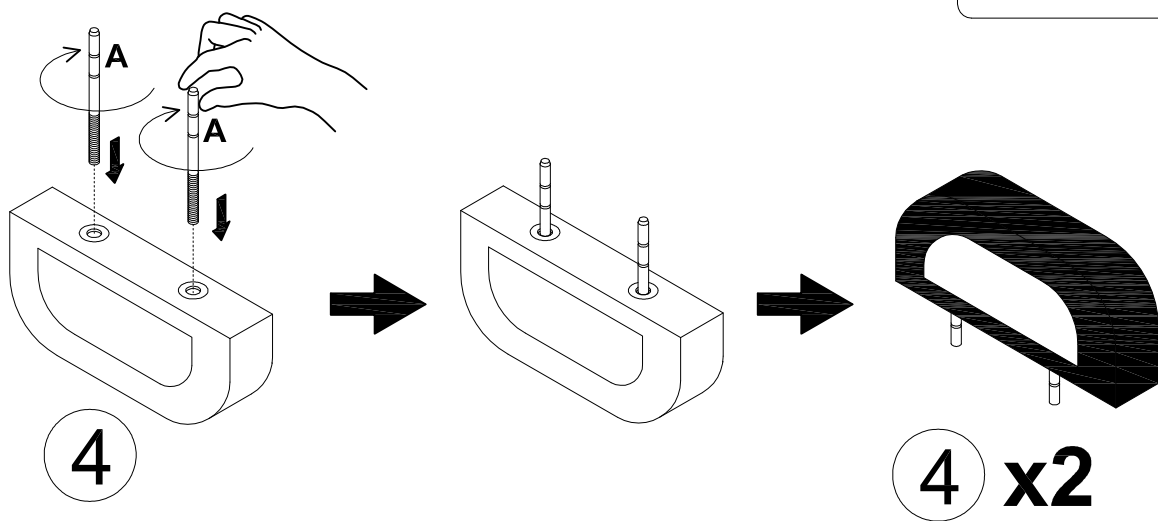

# Assembly Steps

STEP 9:

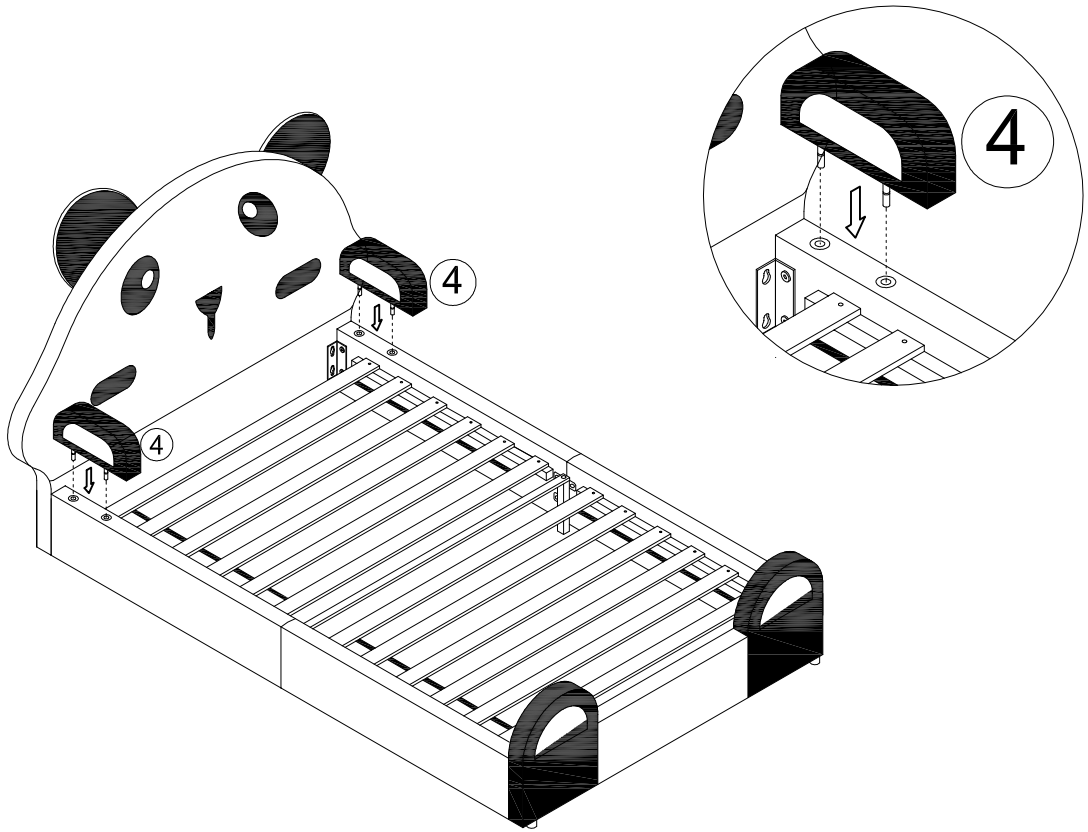

STEP 10:

