

Assembly Instructions

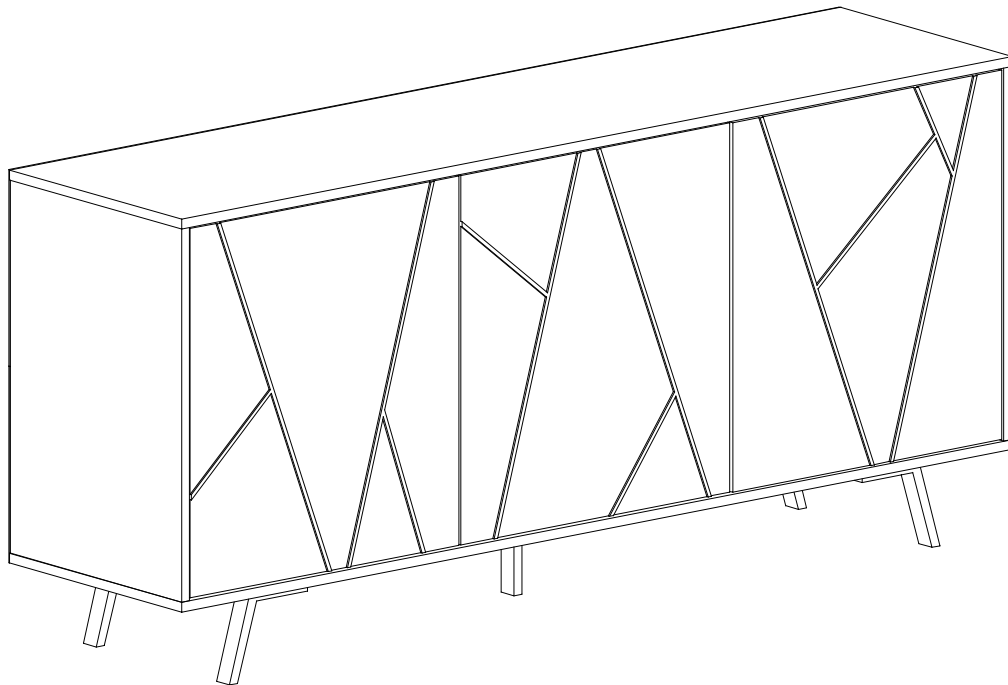

Questions, problems, missing parts? Before returning the product, call our customer service 9 a.m.- 5 p.m., PST, Monday-Friday

IMPORTANT SAFETY INFORMATION



WARNING

DEATH OR SERIOUS INJURY MAY OCCUR WHEN CHILDREN CLIMB ON AUDIO AND/OR VIDEO EQUIPMENT FURNITURE. A REMOTE CONTROL OR TOYS PLACED ON THE FURNISHING MAY ENCOURAGE A CHILD TO CLIMB ON THE FURNISHING AND AS A RESULT THE FURNISHING MAY TIP OVER ON TO THE CHILD.

MUERTE O LESIONES GRAVES PUEDEN OCURRIR CUANDO LOS NIÑOS SUBAN AL AUDIO Y / O MOBILIARIO EQUIPO DE VÍDEO. UN MANDO A DISTANCIA O LOS JUGUETES EXISTENTES EN EL MOBILIARIO PUEDE ANIMAR AL NIÑO A SUBIR A LOS MUEBLES Y COMO RESULTADO EL MOBILIARIO PUEDEN VOLCARSE A LA NIÑO(A).

MORT OU DES BLESSURES GRAVES PEUVENT SE PRODUIRE LORSQUE LES ENFANTS MONTER SUR L'AUDIO ET / OU DES MEUBLES DE L'ÉQUIPEMENT VIDÉO. UNE TÉLÉCOMMANDE OU LES JOUETS MIS SUR L'AMEUBLEMENT PEUVENT ENCOURAGER UN ENFANT À GRIMPER SUR LA FOURNITURE ET COMME RÉSULTAT L'AMEUBLEMENT PEUVENT BASCULER À L'ENFANT.



WARNING

RELOCATING AUDIO AND/OR VIDEO EQUIPMENT TO FURNITURE NOT SPECIFICALLY DESIGNED TO SUPPORT AUDIO AND/OR VIDEO EQUIPMENT MAY RESULT IN DEATH OR SERIOUS INJURY DUE TO THE FURNISHING COLLAPSING OR OVER TURNING ONTO A CHILD.

REUBICACIÓN DE AUDIO Y / O EQUIPO DE VÍDEO A LOS MUEBLES NO ESTÁN DISEÑADOS ESPECÍFICAMENTE PARA APOYAR EL EQUIPO DE AUDIO Y / O VÍDEO PUEDE CAUSAR LA MUERTE O LESIONES GRAVES DEBIDO A LA DECORACIÓN COLAPSE O MÁS DE INFLEXIÓN EN UN NIÑO.

DÉPLACEMENT AUDIO ET / OU VIDÉO À DES MEUBLES PAS SPÉCIFIQUEMENT DESTINÉ À SOUTENIR L'ÉQUIPEMENT AUDIO ET / OU VIDÉO PEUT ENTRAÎNER LA MORT OU DES BLESSURES GRAVES EN RAISON DE LA FOURNITURE DE S'EFFONDRE OU PLUS EN TOURNANT SUR UN ENFANT.

USE AND CARE

1. To clean, use a soft cloth slightly dampened with water.
2. Do not use abrasive cleaners or spray liquids.
3. Using solvents of any kind on your furniture may damage your furniture's finish.
4. Liquid spills should be removed immediately. Using a soft clean cloth, blot the spill gently. Avoid rubbing.
5. Stains or marks from crayons or ink markers will be difficult to remove.
6. Do not climb or step on the stand.
7. Periodically check that all fasteners are tightened.

-
1. Para limpiar, use un paño suave ligeramente humedecido con agua.
 2. No use limpiadores abrasivos o rociadores.
 3. El uso de disolventes de ningún tipo sobre sus muebles pueden dañar el acabado de sus muebles.
 4. Los derrames de líquidos deben ser retirados inmediatamente. Con un paño suave y limpio, seque el derrame suavemente. Evite frotar.
 5. Las manchas o marcas de crayones o marcadores de tinta serán difíciles de eliminar.
 6. No se suba o pisar el stand.
 7. Compruebe periódicamente que todos los sujetadores estén apretados.

-
1. Pour nettoyer, utilisez un chiffon doux légèrement humidifié avec de l'eau.
 2. Ne pas utiliser de nettoyeurs abrasifs ou de liquides en aérosol.
 3. L'utilisation de solvants d'aucune sorte sur vos meubles peut endommager le fini de votre mobilier.
 4. Les déversements de liquides doivent être retirés immédiatement. L'utilisation d'un chiffon propre et doux, éponger délicatement le déversement. Évitez de frotter.
 5. Taches ou les marques de crayons ou des marqueurs d'encre sera difficile à enlever.
 6. Ne pas monter ou marcher sur le stand.
 7. Vérifier périodiquement que toutes les fixations sont serrées.

MAXIMUM WEIGHT: 75 LBS (34 KG)
PESO MÁXIMO: 75 LIBRAS (34 KILOGRAMO)
POIDS MAXIMUM: 75 LIVRES (34 KILOGRAMME)

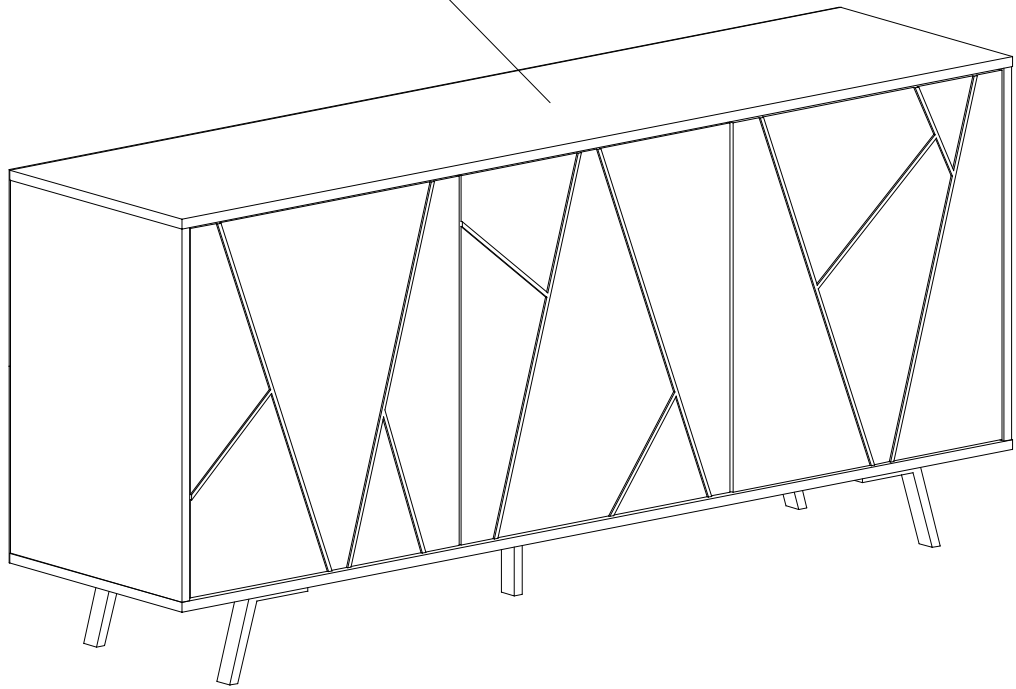

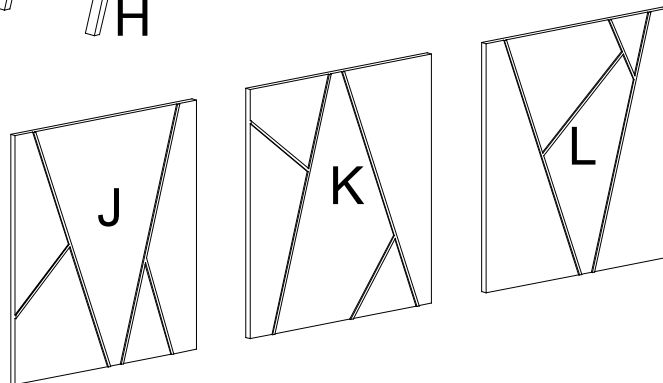
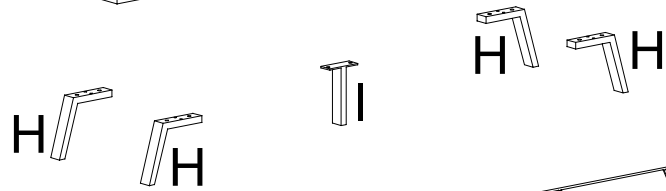
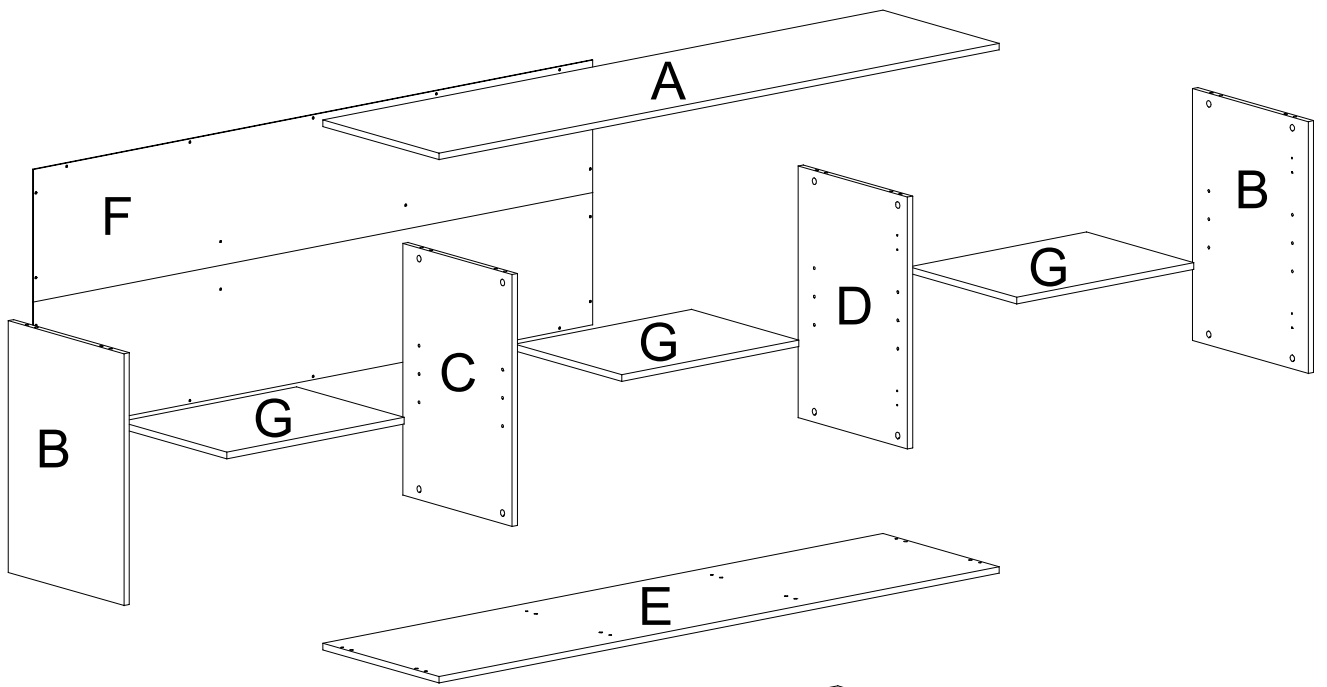

HARDWARE

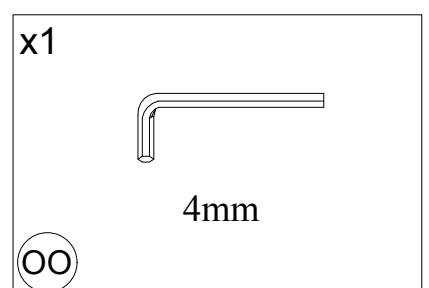
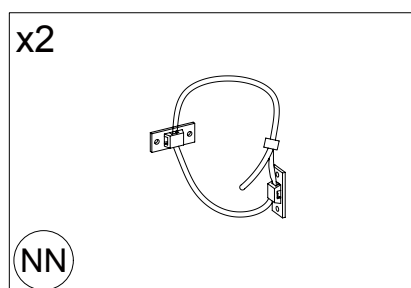
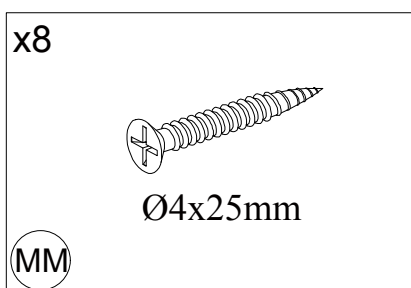
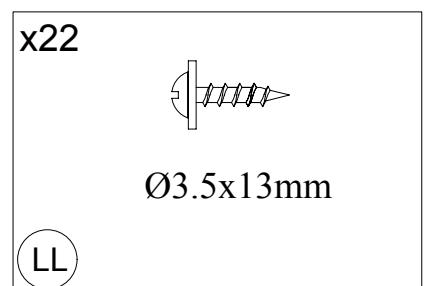
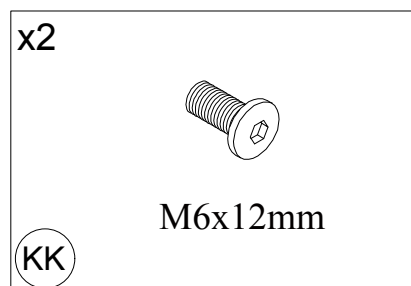
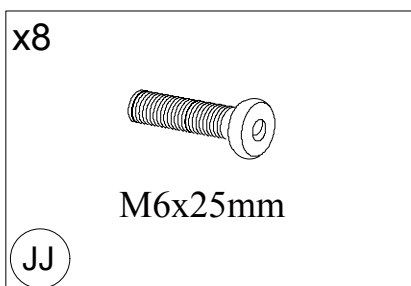
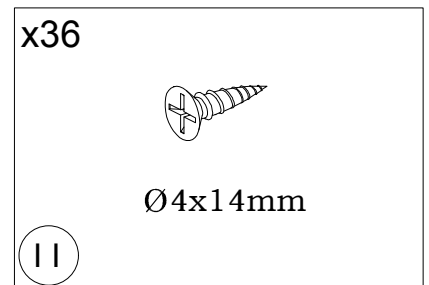
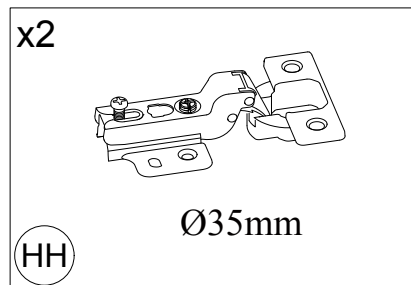
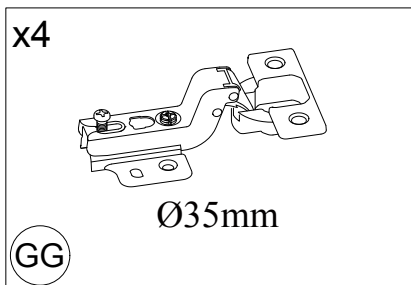
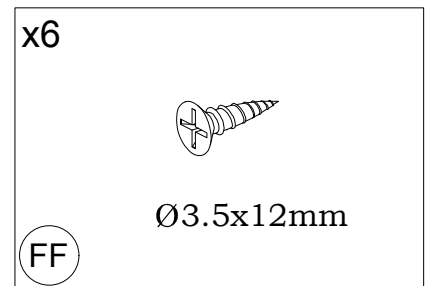
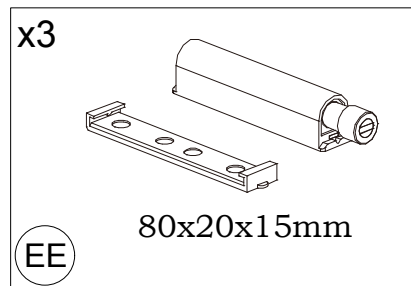
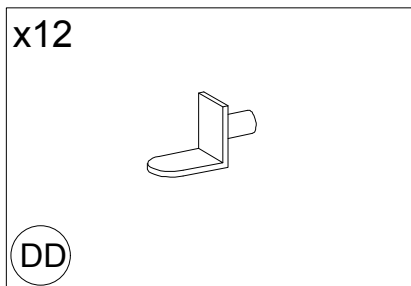
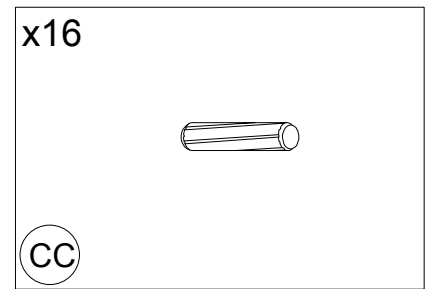
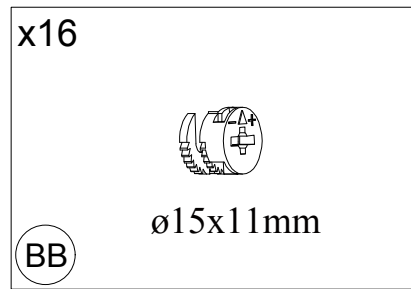
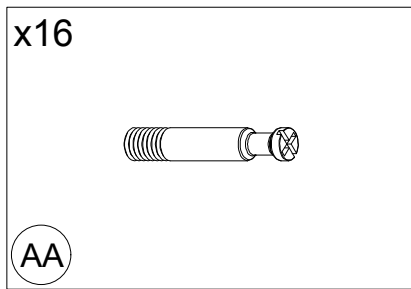

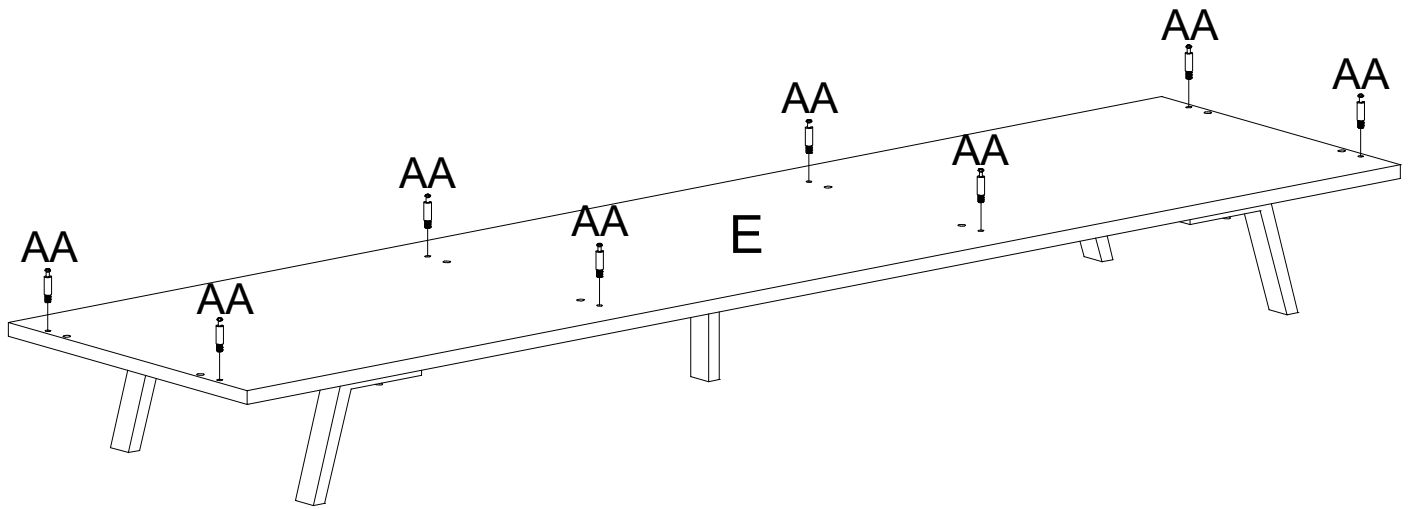
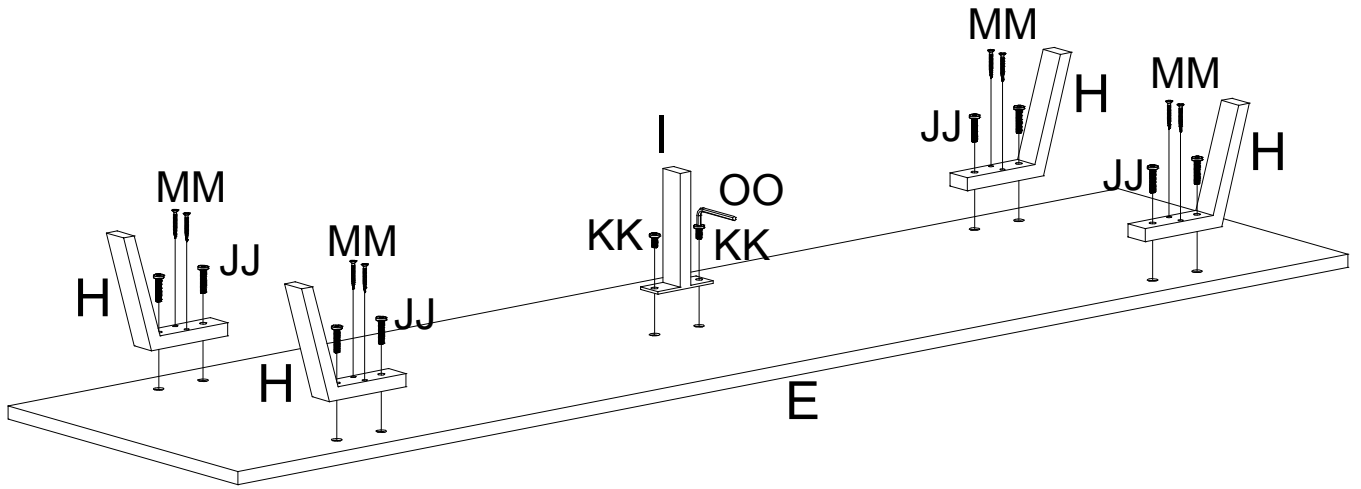

AA



[x8]

JJ

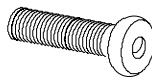

[x8]

KK

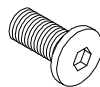

[x2]

MM

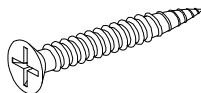

[x8]

OO



[x1]

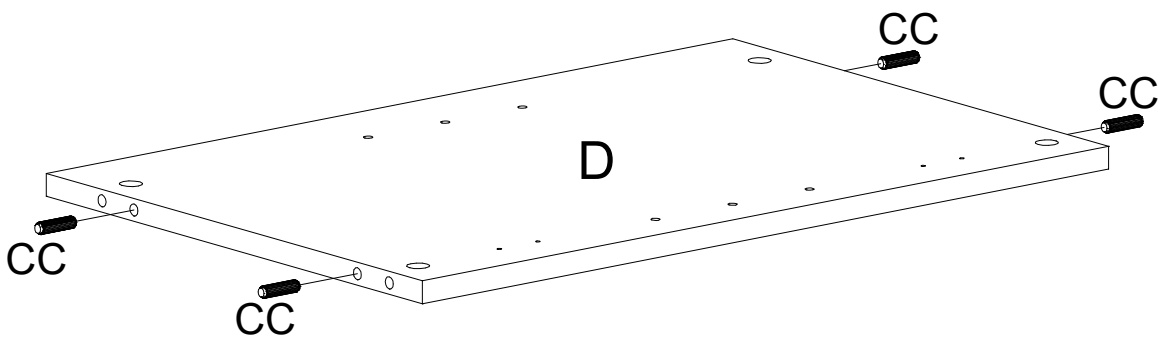
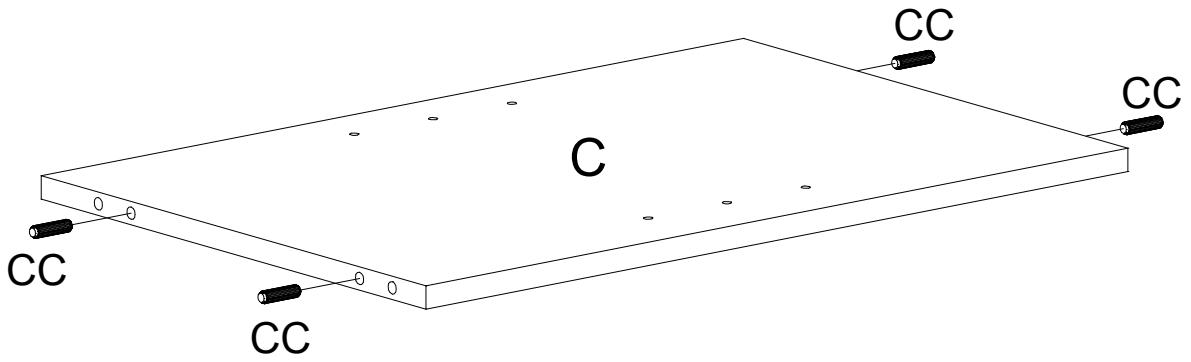
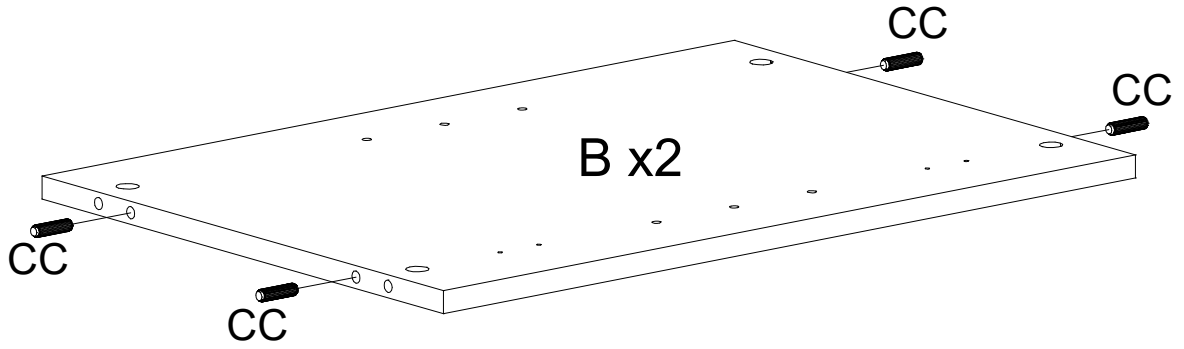

[x16]



These holes are in front

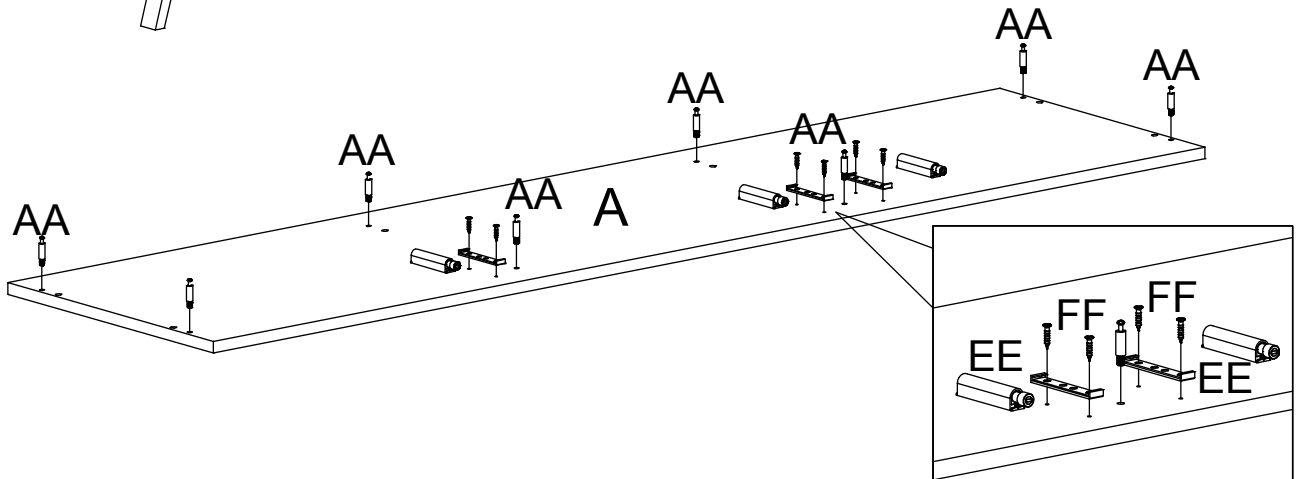
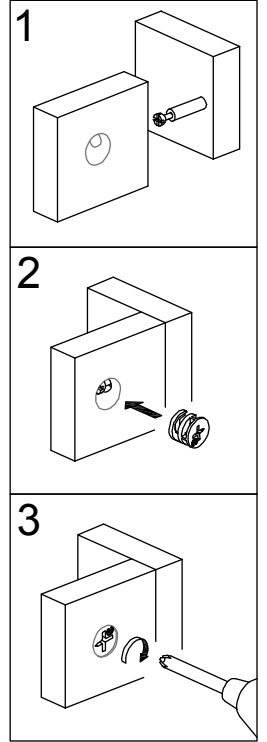
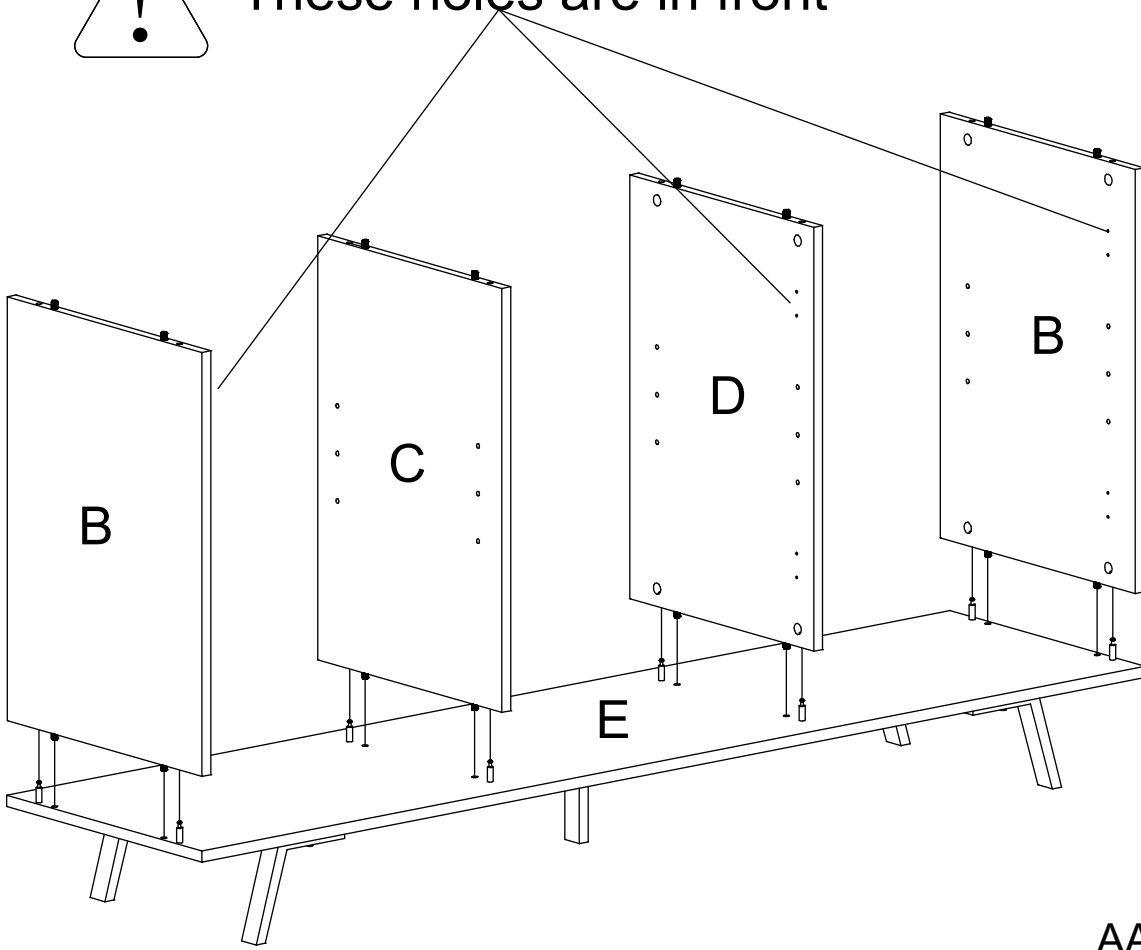

AA

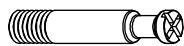

[x8]

BB



[x8]

EE

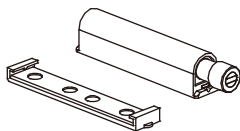

[x3]

FF

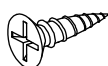

[x6]

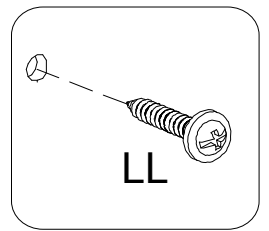
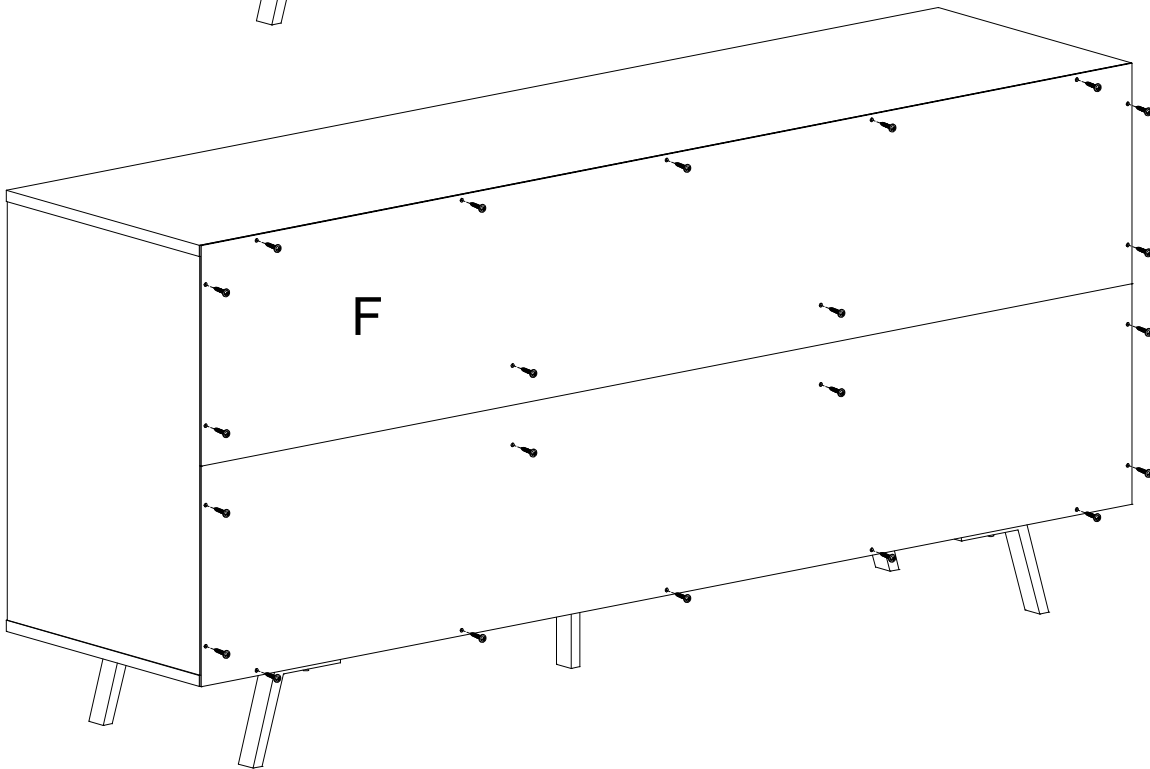
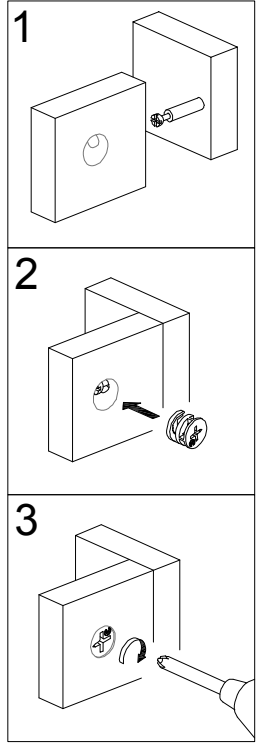
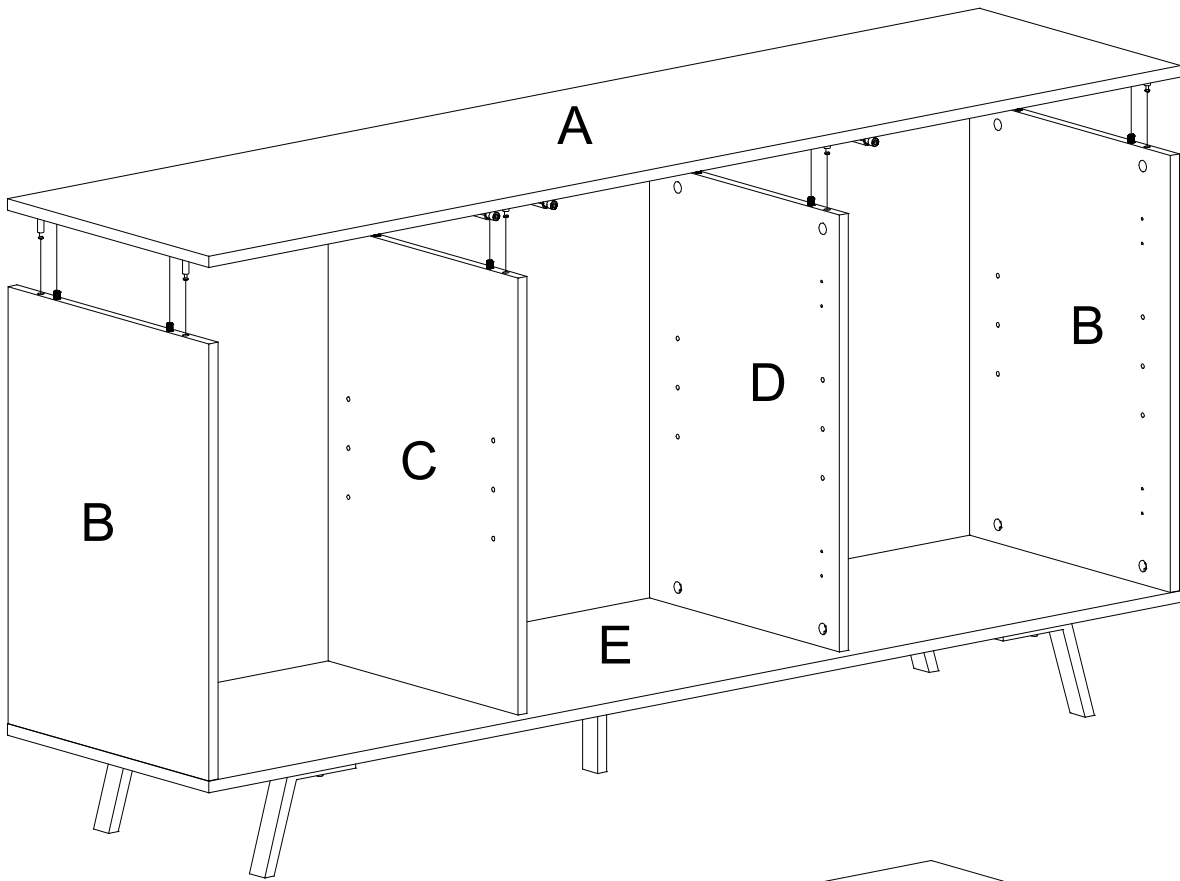

BB



[x8]

LL

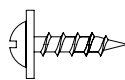

[x22]

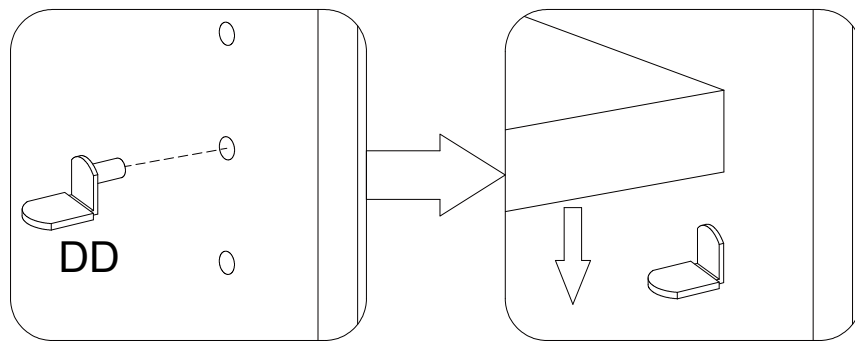
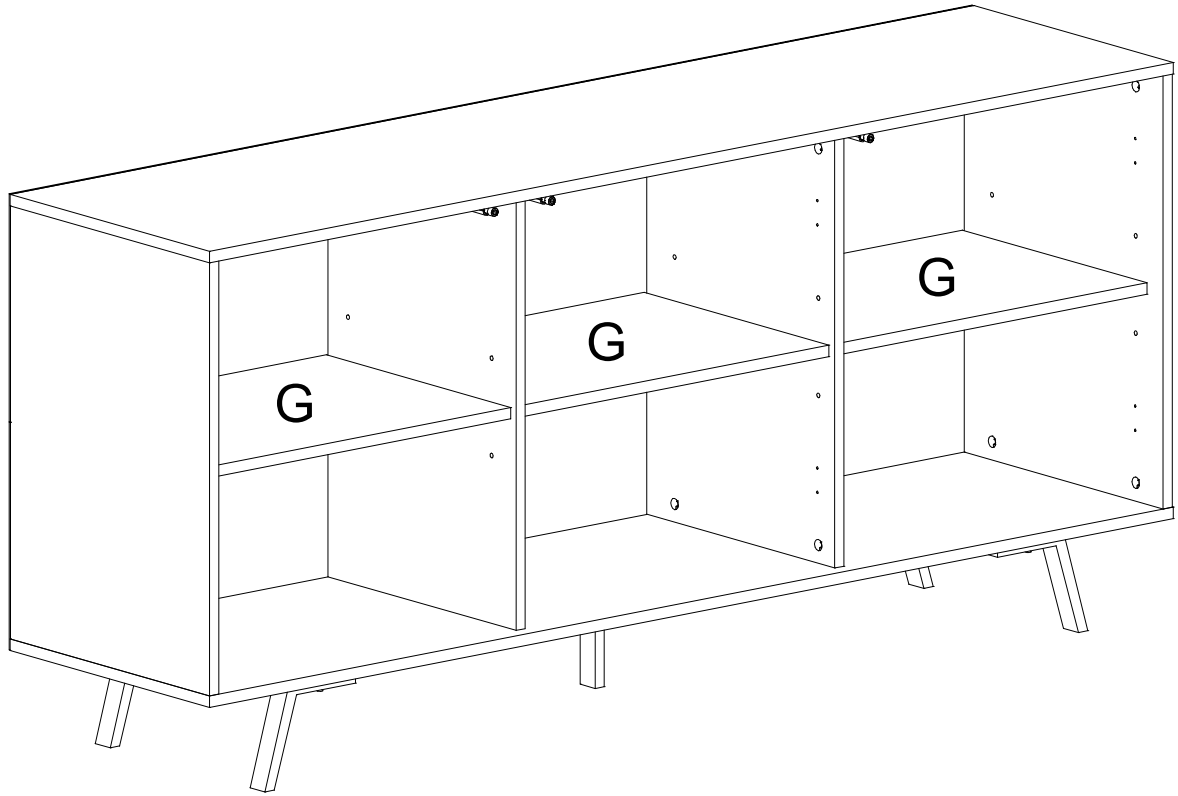

DD

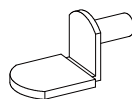

[x12]

6

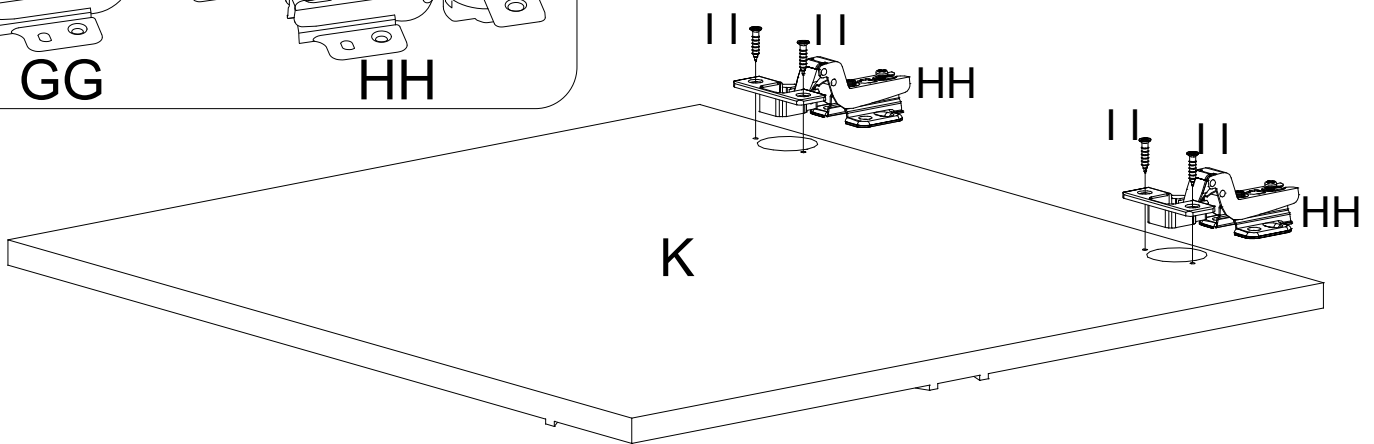
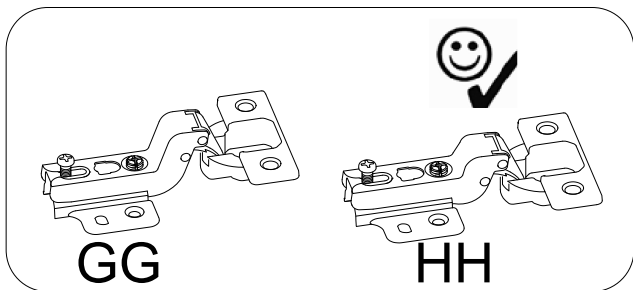
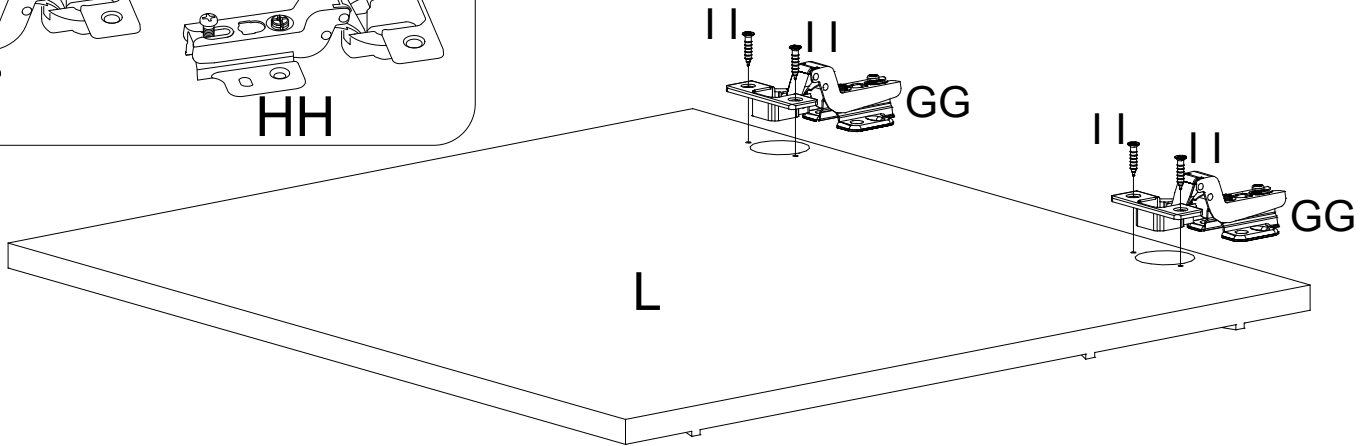
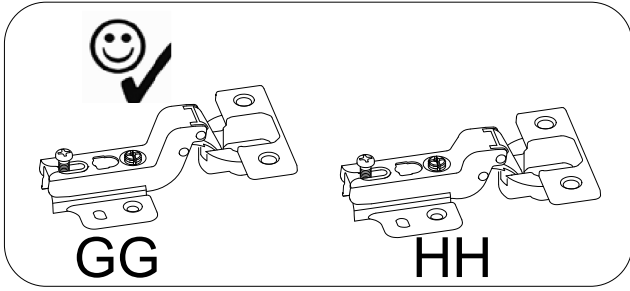
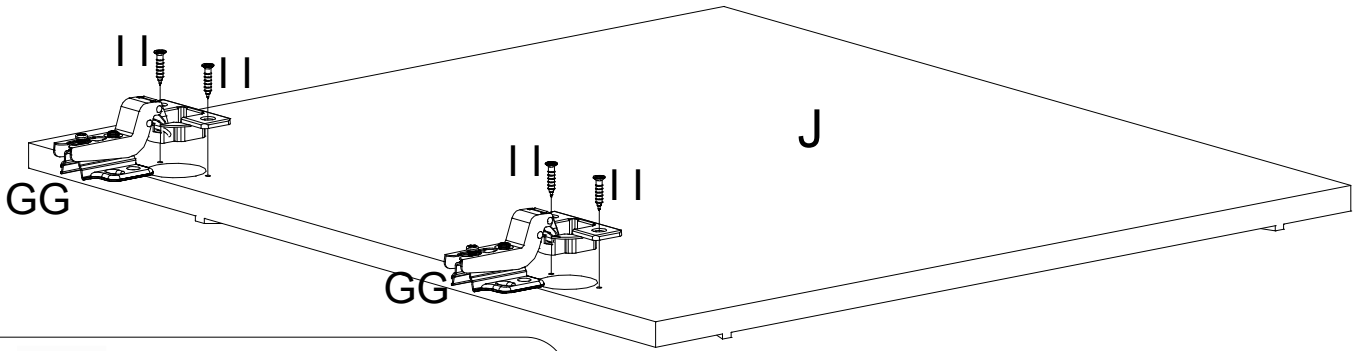

GG

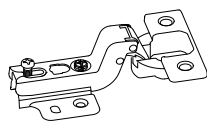

[x4]

HH

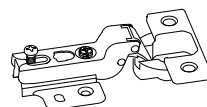

[x2]

II

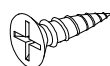

[x12]

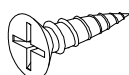
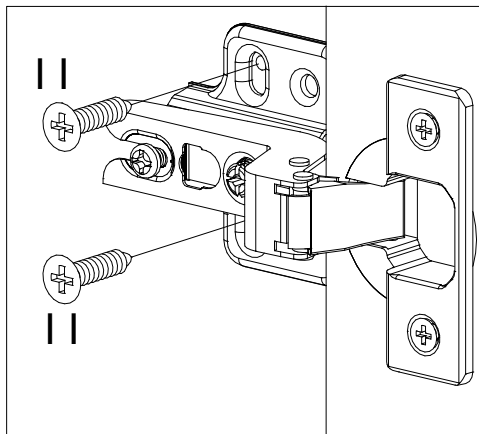
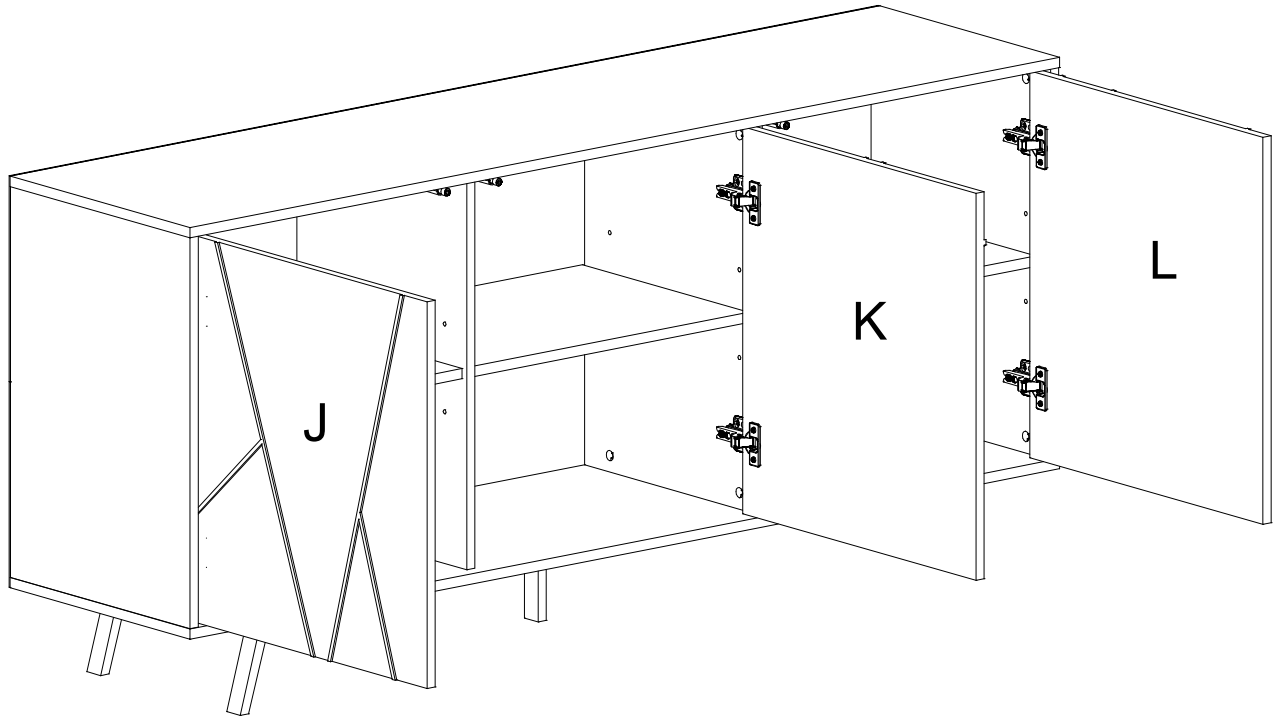

Doors don't line up? There is noticeable gap between two doors? Don't worry, refer to below instructions to adjust the hinges to fix the door disalignment or gap problems.

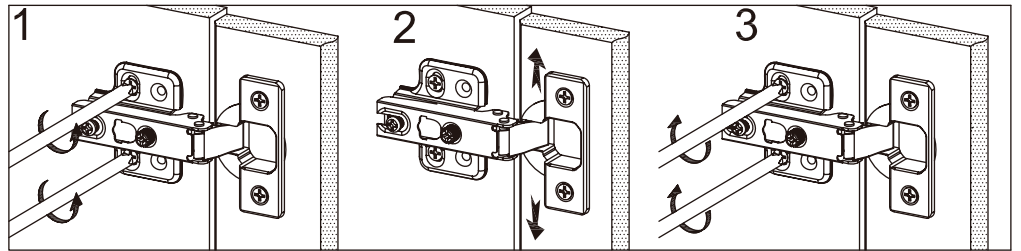
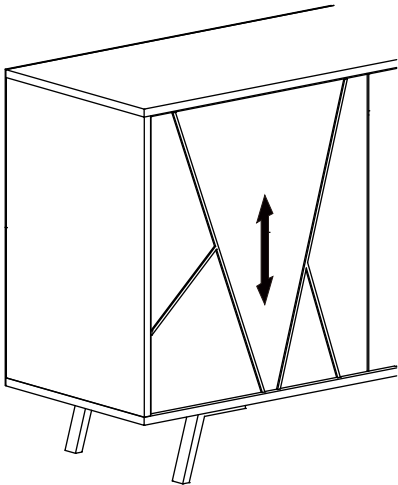

Loosen screws on hinges to adjust the door up and down. Then tighten screws.

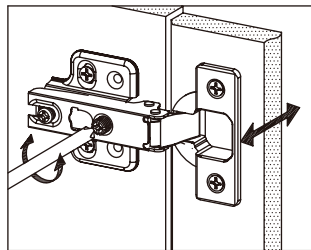
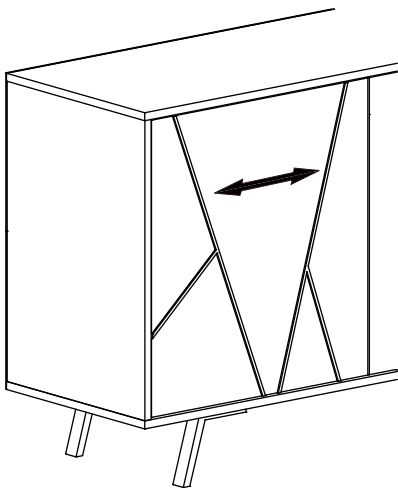

Turning the screw to adjust the door right and left

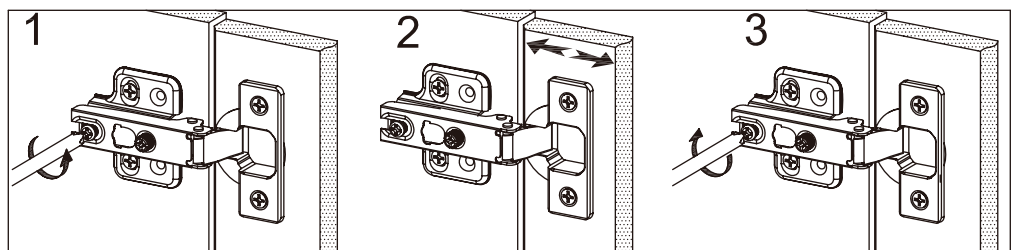
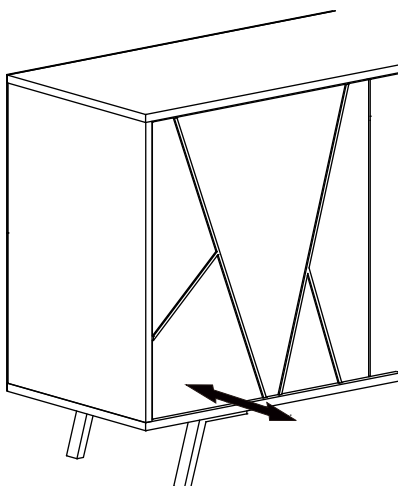

Loosen screws on hinges to move the door inward or outward. Then tighten screws.

9

You can make gap adjustment when doors does not open correctly or smoothly by pop out the ejector pin and rotate it out to the proper length.

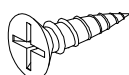
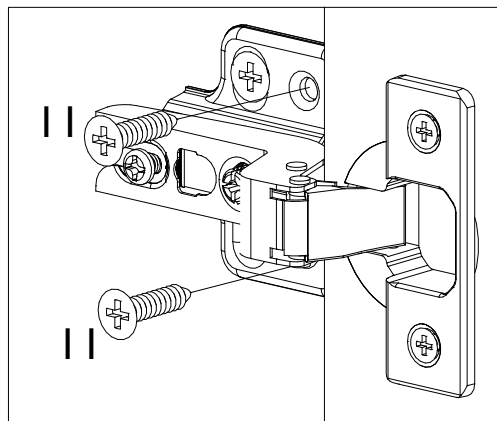
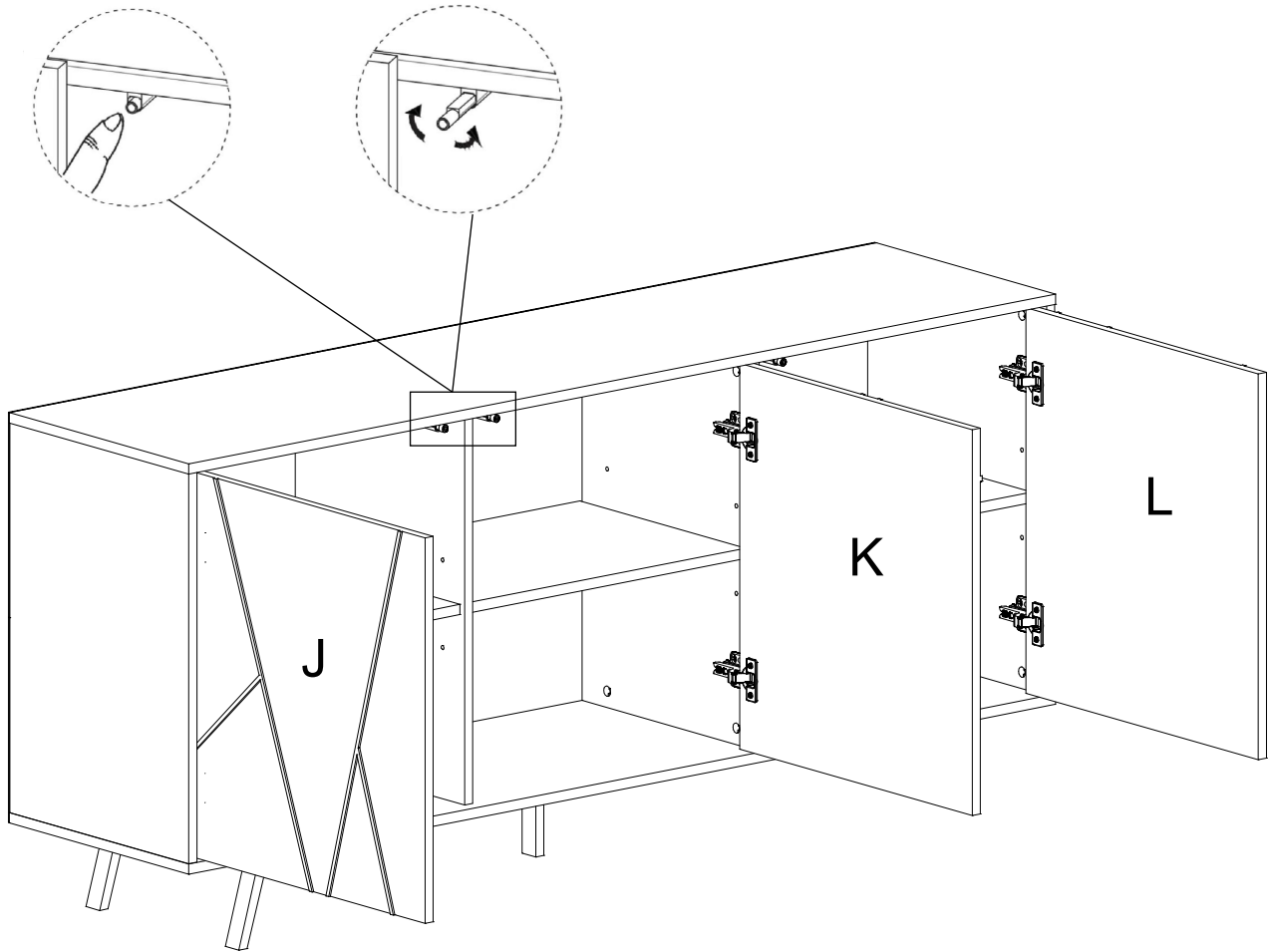

[x12]

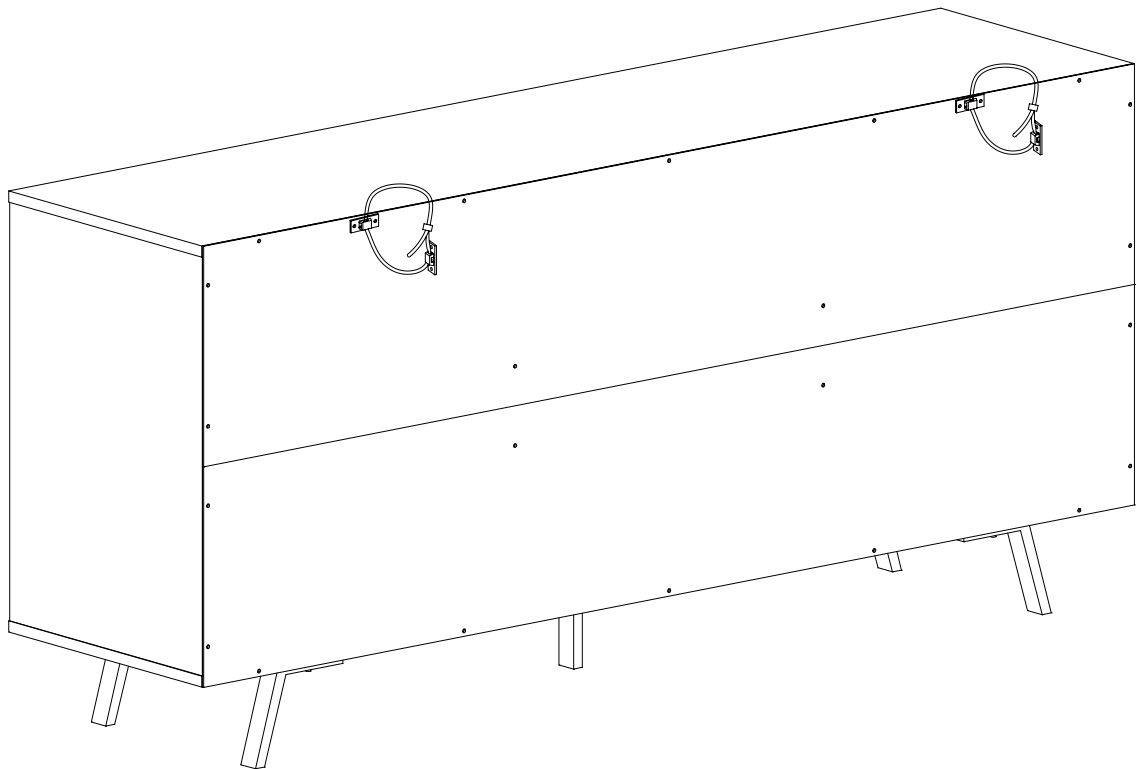
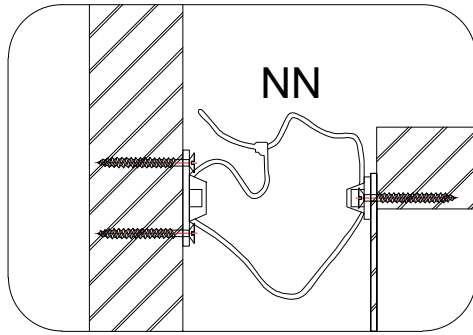

NN

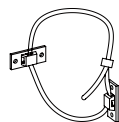

[x2]