

DOUBLE GLASS BARN DOOR ASSEMBLY INSTRUCTIONS

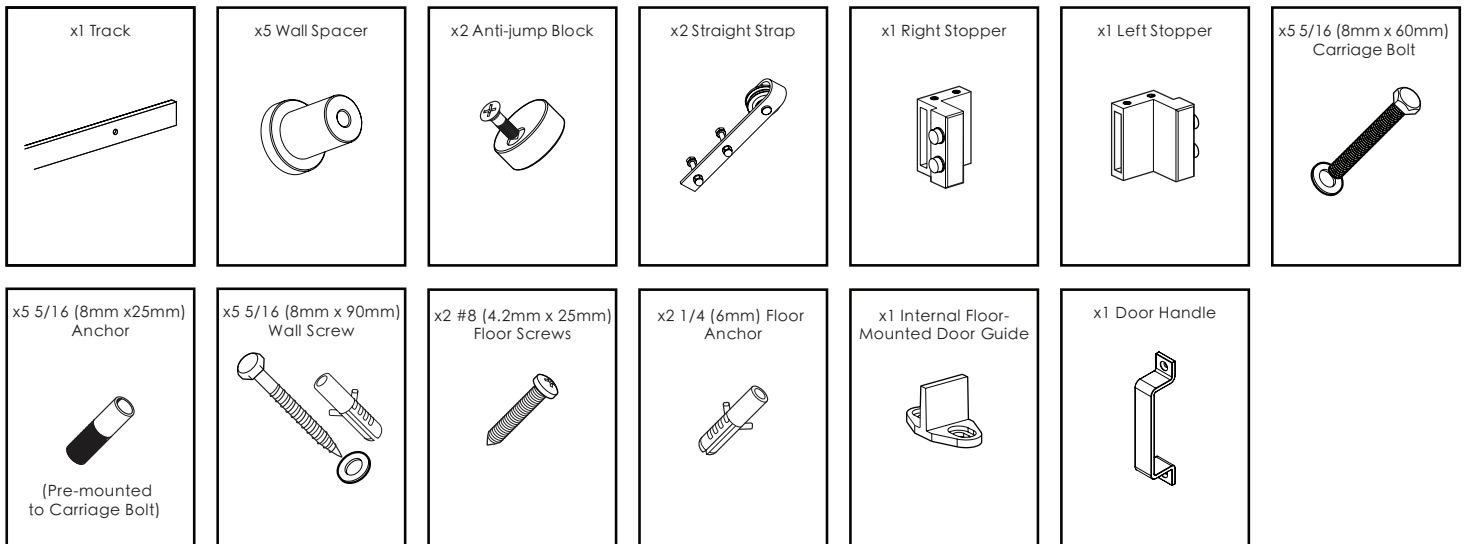

BARN DOOR HARDWARE INSTRUCTIONS

Kit Components



Tools Required

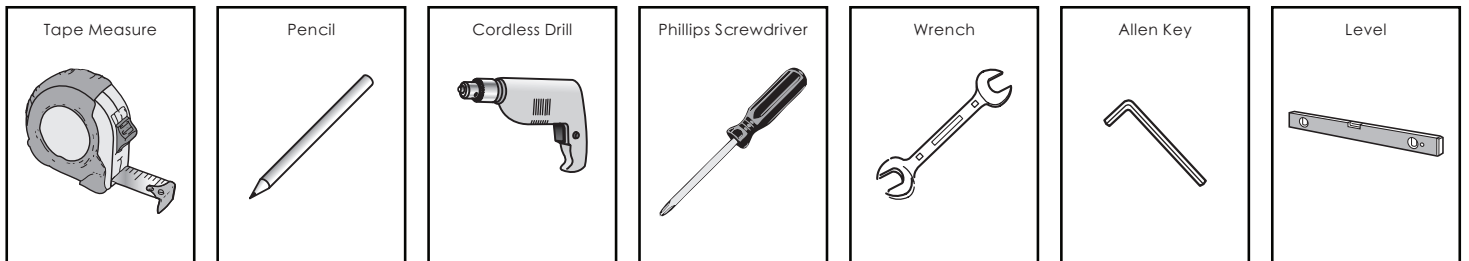

Door Preparation - Strap and Anti-jump block

Your Barn Door arrives with holes for the hanging straps pre-drilled. Use the included carriage bolts to attach the straps to the door.

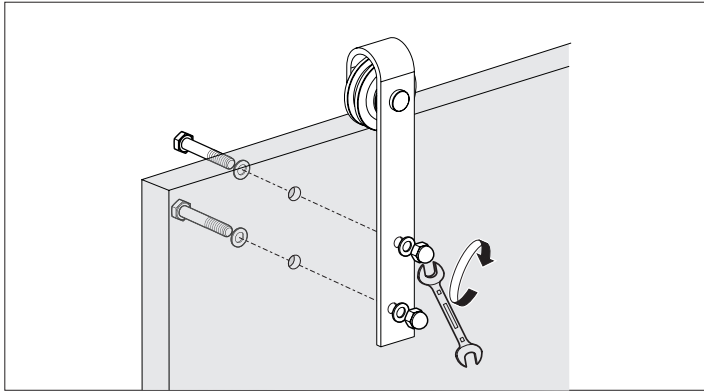

Next, position each anti-jump bumper at least 2" in from the edge of the straps. Tighten slightly to secure in place

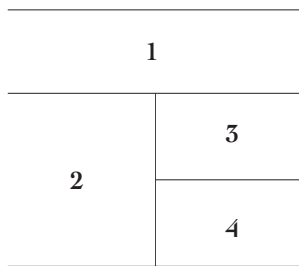
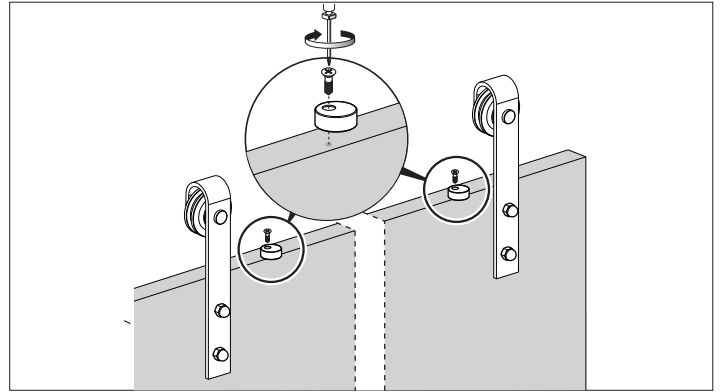

Step 1. CONCRETE Wall Preparation

FOR DRYWALL INSTALLATION – PLEASE PROCEED TO STEP 4.

Add +1 3/4" to the door height (H) and measure up from the floor to find the height of the center of the track. Ensure a gap of 3/8" - 1/2" at the bottom of the door and make marks on the wall on both the left and right sides of the door opening. A minimum of 2" track clearance must be maintained on both the left and right sides of the door opening.

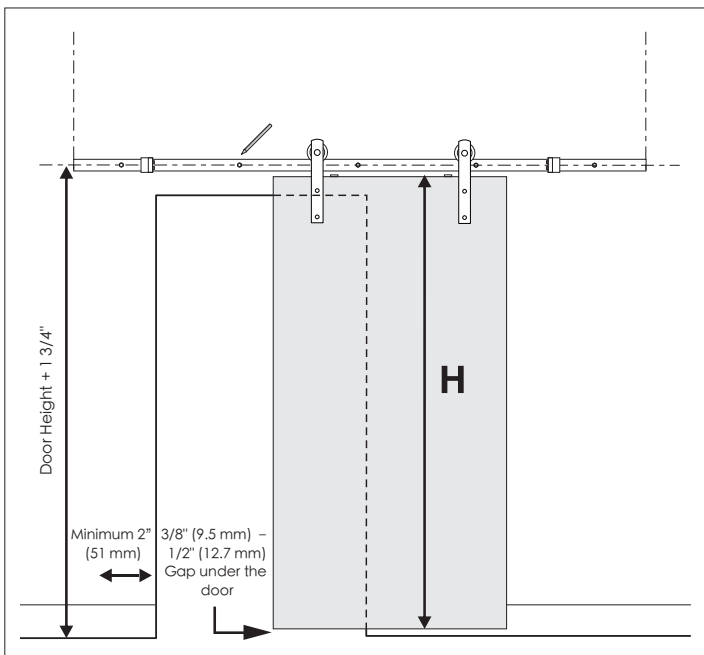

Step 2. CONCRETE Wall Preparation

Use your guide marks to position the track in place, ensuring that it is level. Mark the mounting holes on the track using a pencil. Then, pre-drill 5/16" holes into the concrete according to your marks.

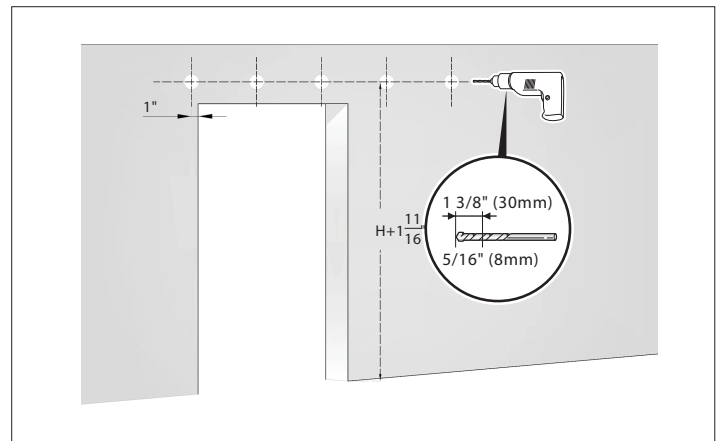

Step 3. CONCRETE Track Installation

Insert the provided anchors and carriage bolts (with washers). Unscrew and separate the carriage bolts and anchors, and take care to install correctly, securing with a wrench.

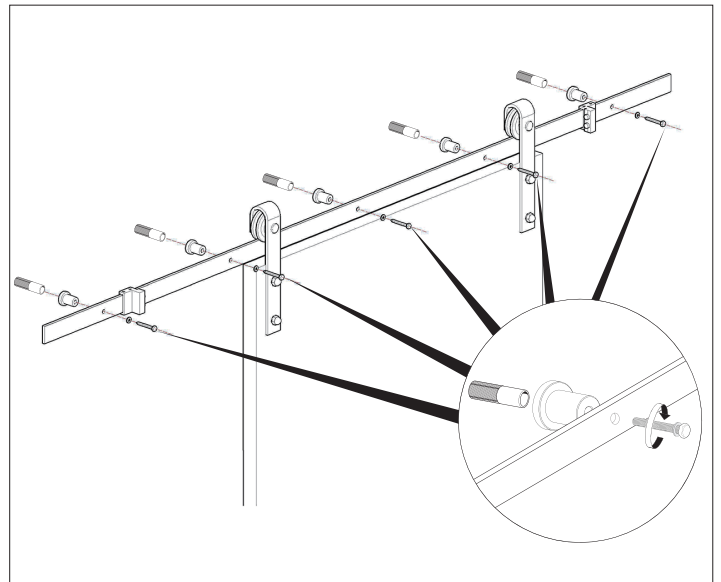

1	3
2	4

Step 4. DRYWALL Wall Preparation

Add $+1\frac{3}{4}"$ to the door height (H) and measure up from the floor to find the height of the center of the track. Ensure a gap of $\frac{3}{8}" - \frac{1}{2}"$ at the bottom of the door and make marks on the wall on both the left and right sides of the door opening. A minimum of 2" track clearance must be maintained on both the left and right sides of the door opening.

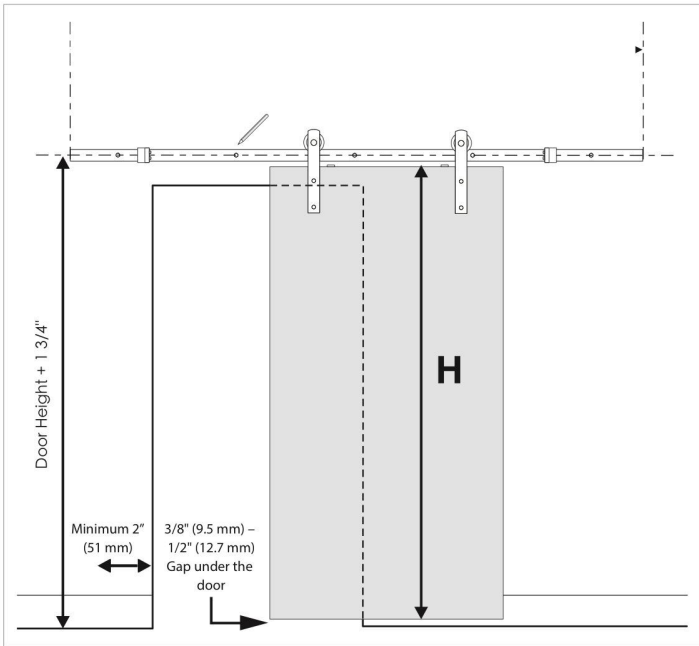

Step 5. DRYWALL Wall Preparation

Use your guide marks to position the track in place, ensuring that it is level. Mark the mounting holes on the track using a pencil. You do not need to pre-drill the holes.

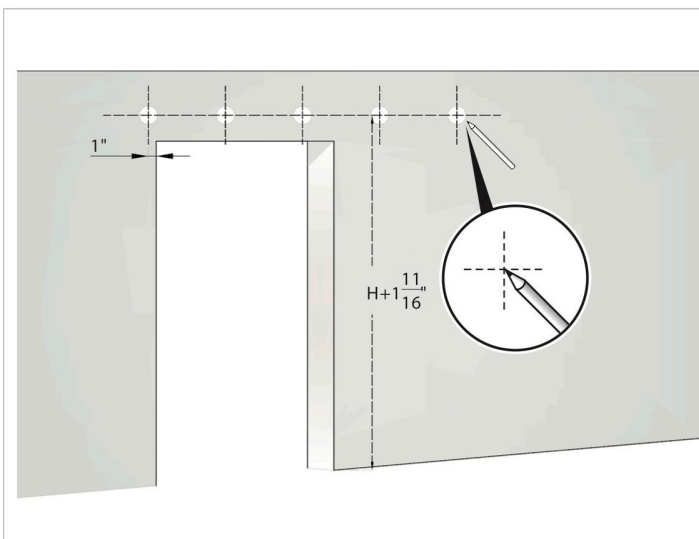

Step 6. DRYWALL Track Installation

When installing into the wall, insert using the provided wall screws. Align each spacer to the track holes, inserting spacers and screws (with washers), securing with a wrench.

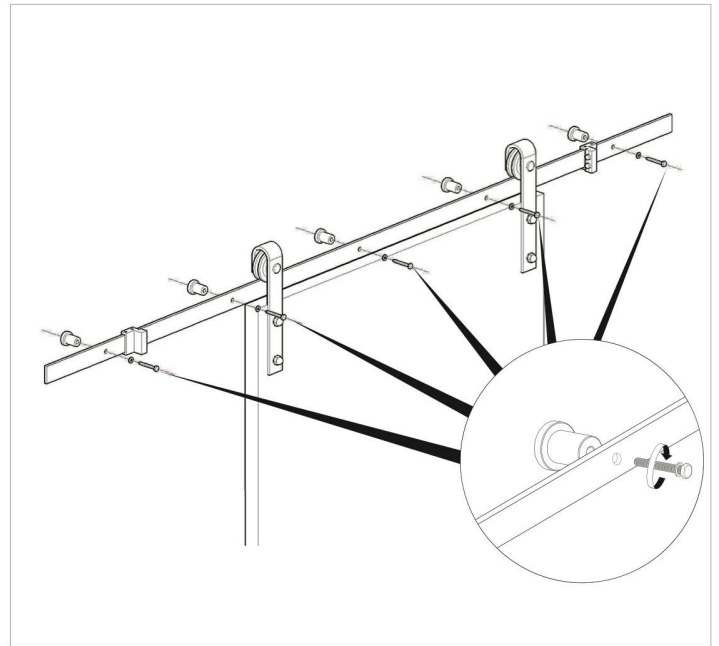

Step 7. Hanging the Door

Place the assembled door onto the secured track and rotate each anti-jump bumper so that it provides a buffer between the track and the door. Test for proper operation by sliding the door side-to-side.

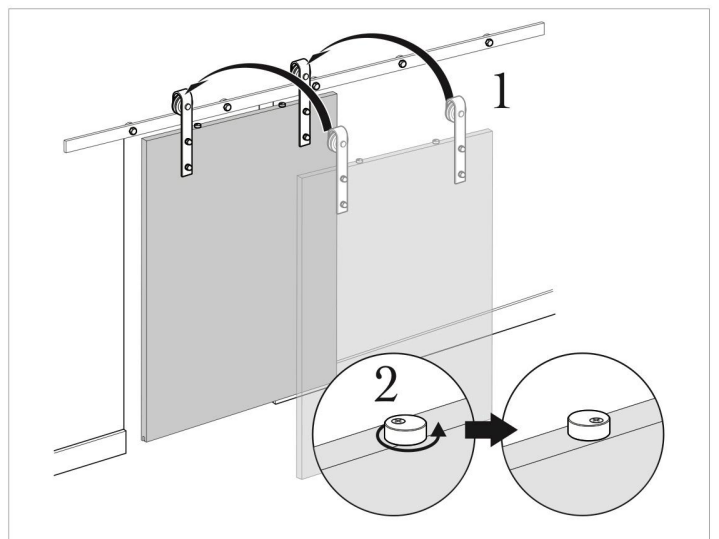

Step 8. Floor-Mounted Door Guide Installation

Position the floor-mounted door guide just outside the opening of the door frame. Slide the door side-to-side to test for functionality, then mark the holes with a pencil and pre-drill 1/4" holes. If drilling directly into a concrete floor, use the provided anchors.

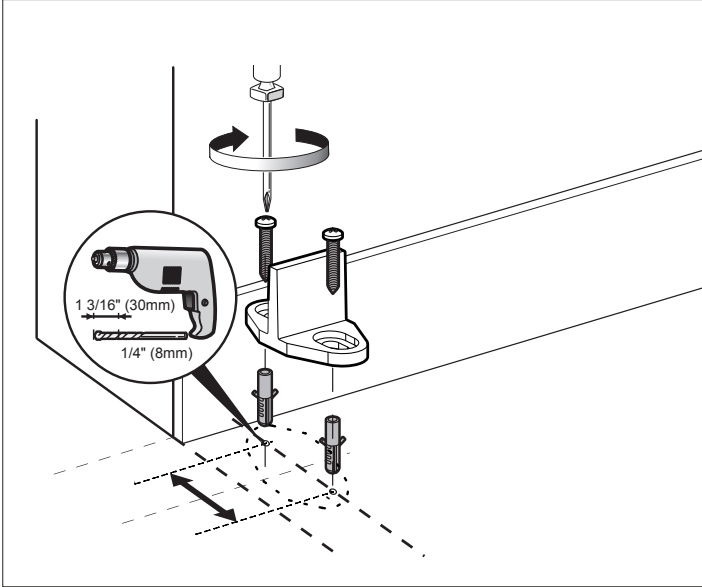

Step 9. Stopper Installation

Slide the left and right stoppers onto the track and find the ideal location by testing the door in both open and closed positions. Using Allen key, tighten the stoppers into position.

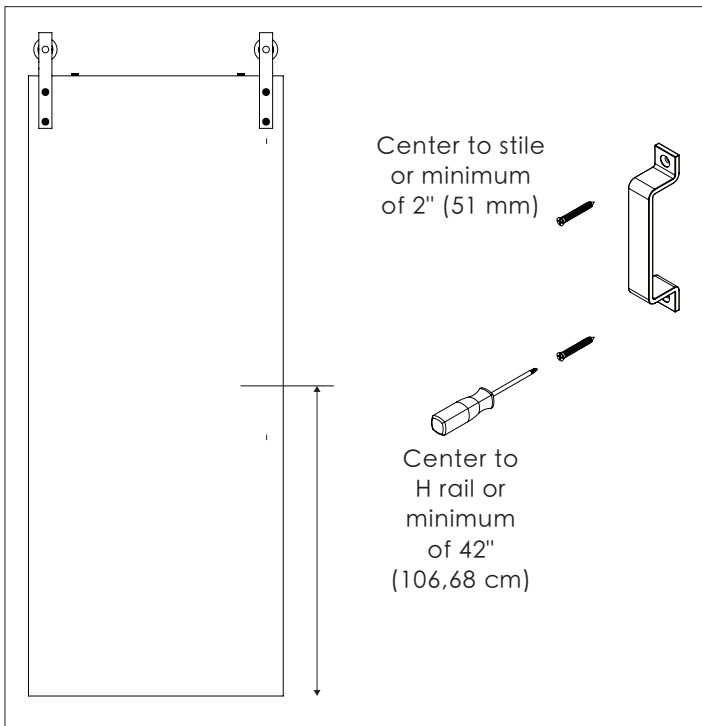
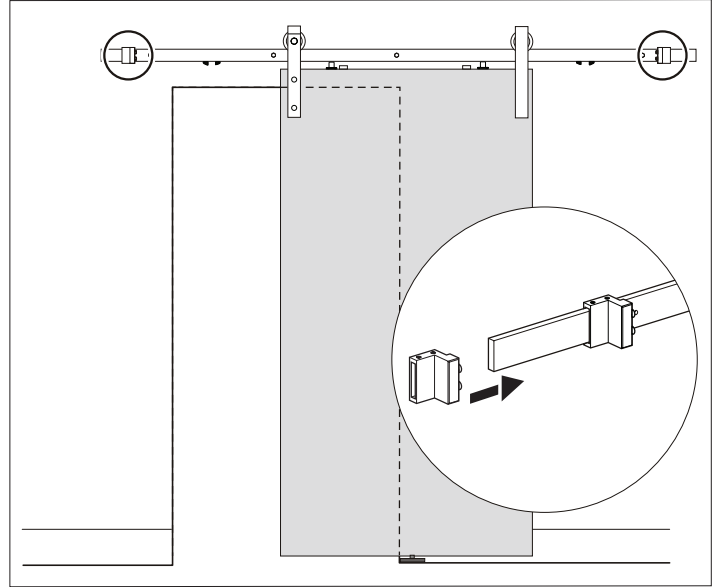

1	
2	3

Step 10. Door Handle Installation

Position the handle on the outer, pulling side of the door and measure a minimum of 2" (51 mm) from the outer edge or to the center of the stile (see picture below). Next measure up 42" (106 cm) from the floor, or center using the horizontal slat across the middle of the door to find the handle mounting position.

With your handle centered at your measurement marking, mark both holes and pre-drill pilot holes 1 1/8" deep before installing the handle. For soft wood like Pine, the size of drill bit recommended is 1/8". Secure the handle using a hand screwdriver.

Note: using an electric powered drill to secure screws may damage the screw and door.