

ASSEMBLY INSTRUCTION

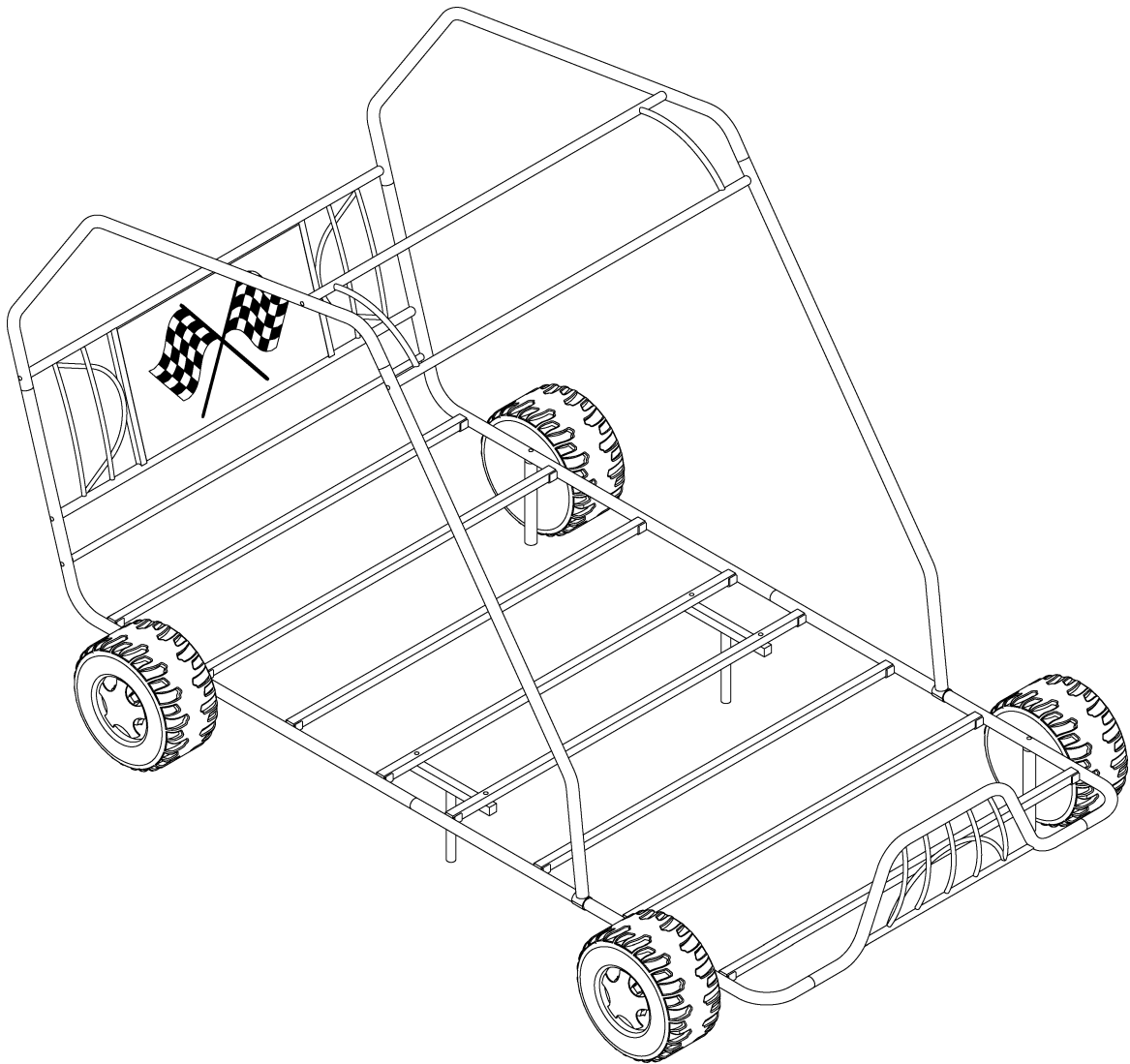

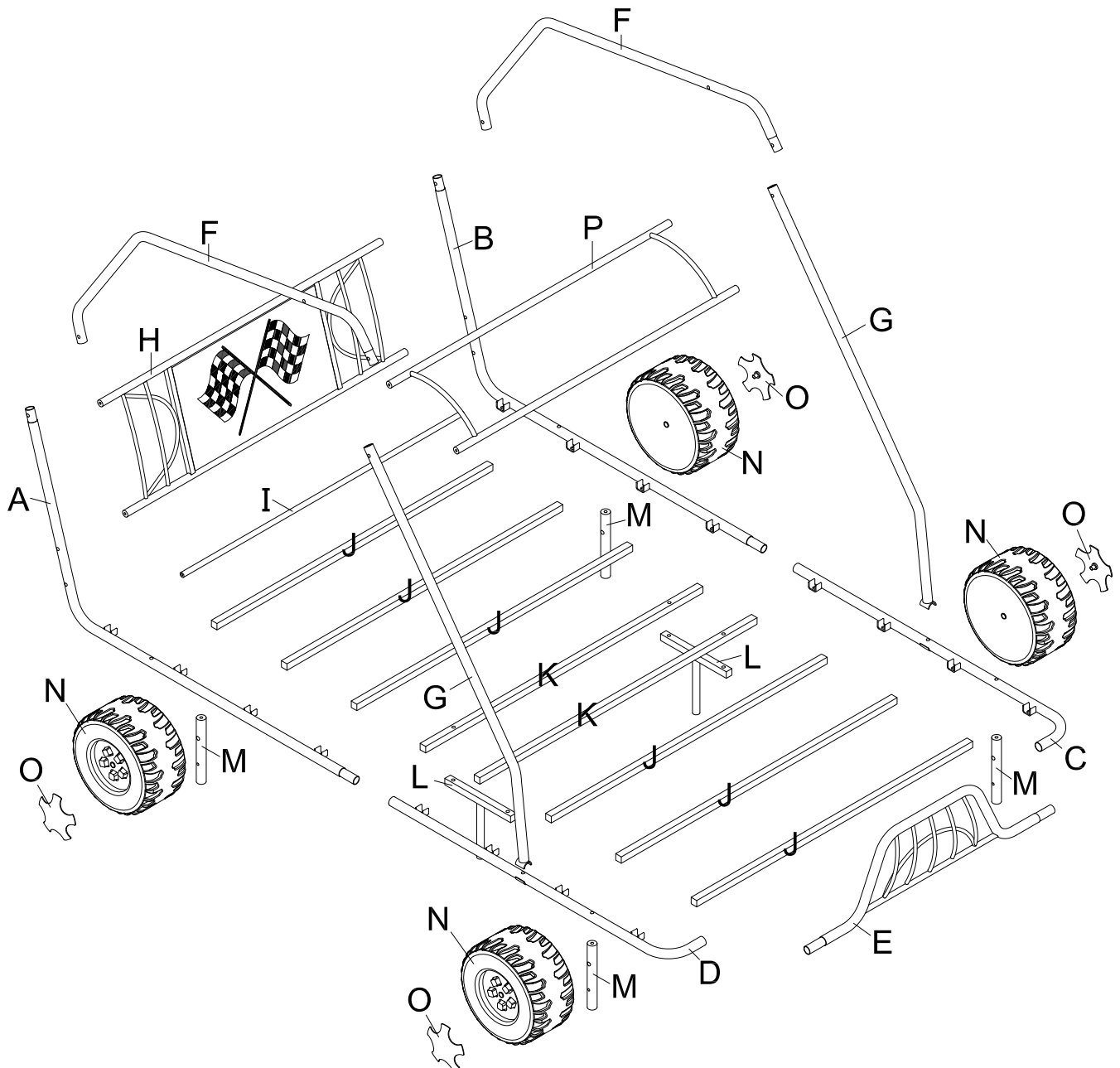





Do not tighten screws until completely assembled.

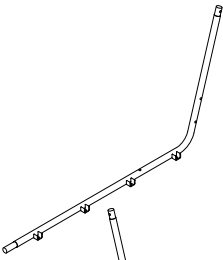
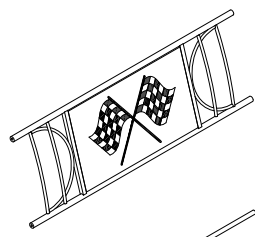
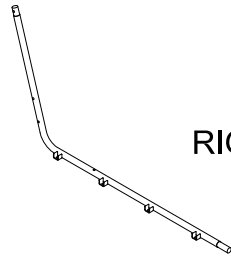
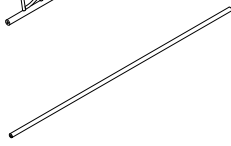
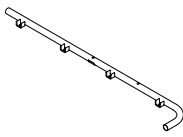
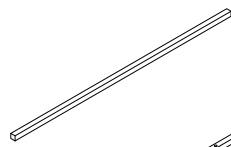
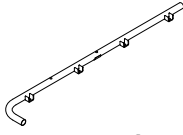
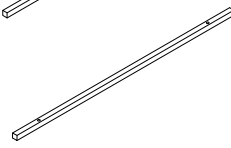
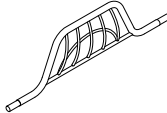



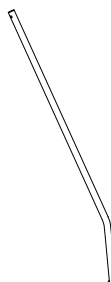

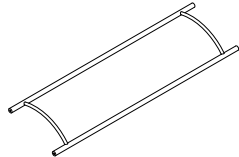

PARTS IDENTIFICATION



PARTS IDENTIFICATION

A		LEFT 1pc		H		1pc
B		RIGHT 1pc		I		1pc
C		LEFT 1pc		J		6pcs
D		RIGHT 1pc		K		2pcs
E		1pc		L		2pcs
F		2pcs		M		4pcs
G		2pcs		N		4pcs
				O		4pcs
				P		1pc

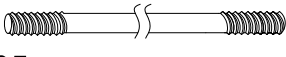
HARDWARE LIST

1  M6x15 12pcs	2  M6x30 4pcs	3  M6x40 16pcs
4  M4x40 4pcs	5  5x5 1pc	6  M8x18 4pcs
7  M8x195 4pcs	8  4x4 1pc	9  ø16xø7x1.0 4pcs

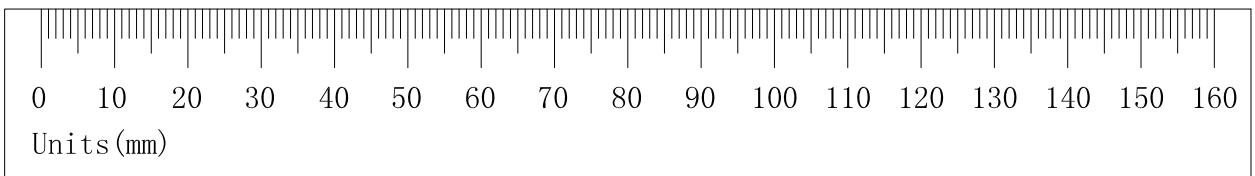

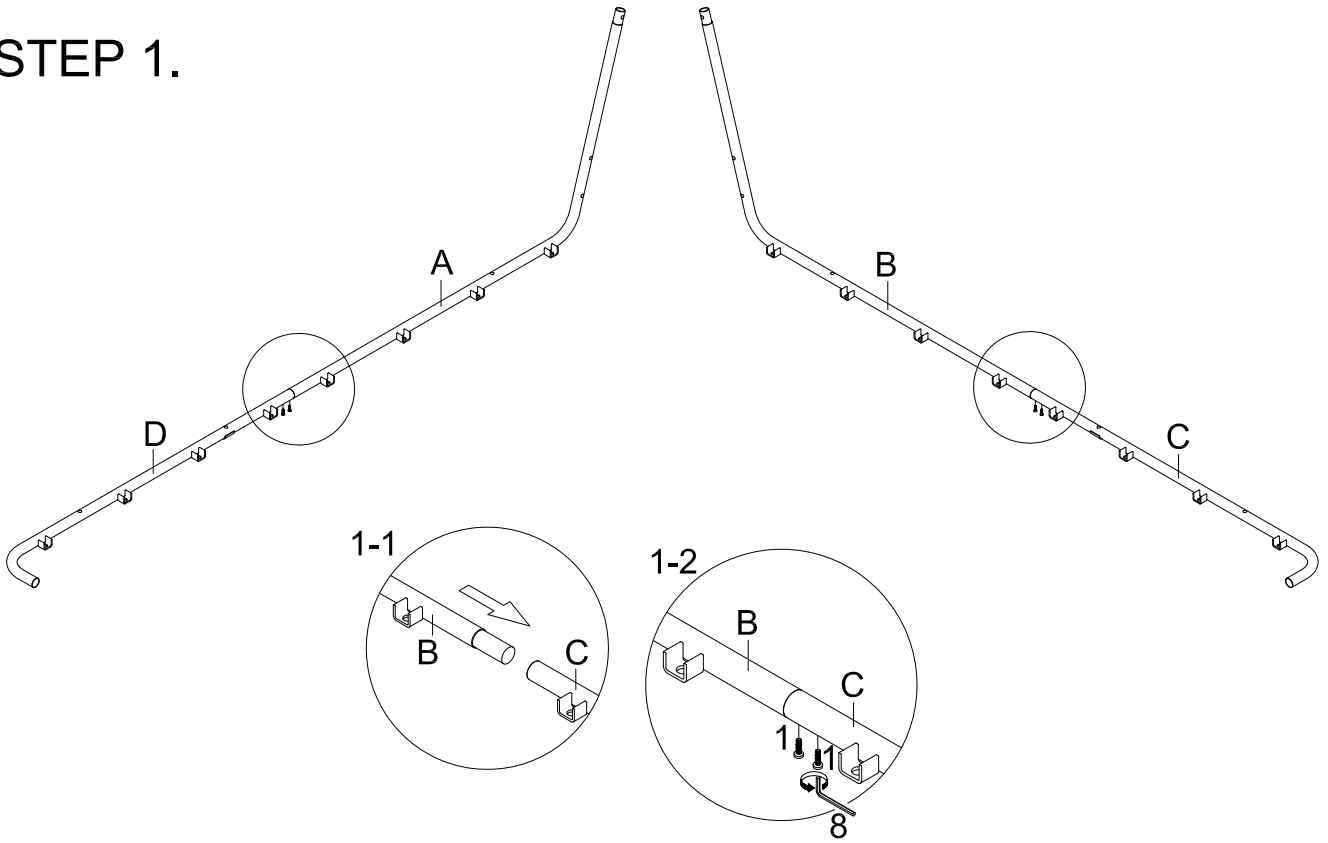

STEP 1.

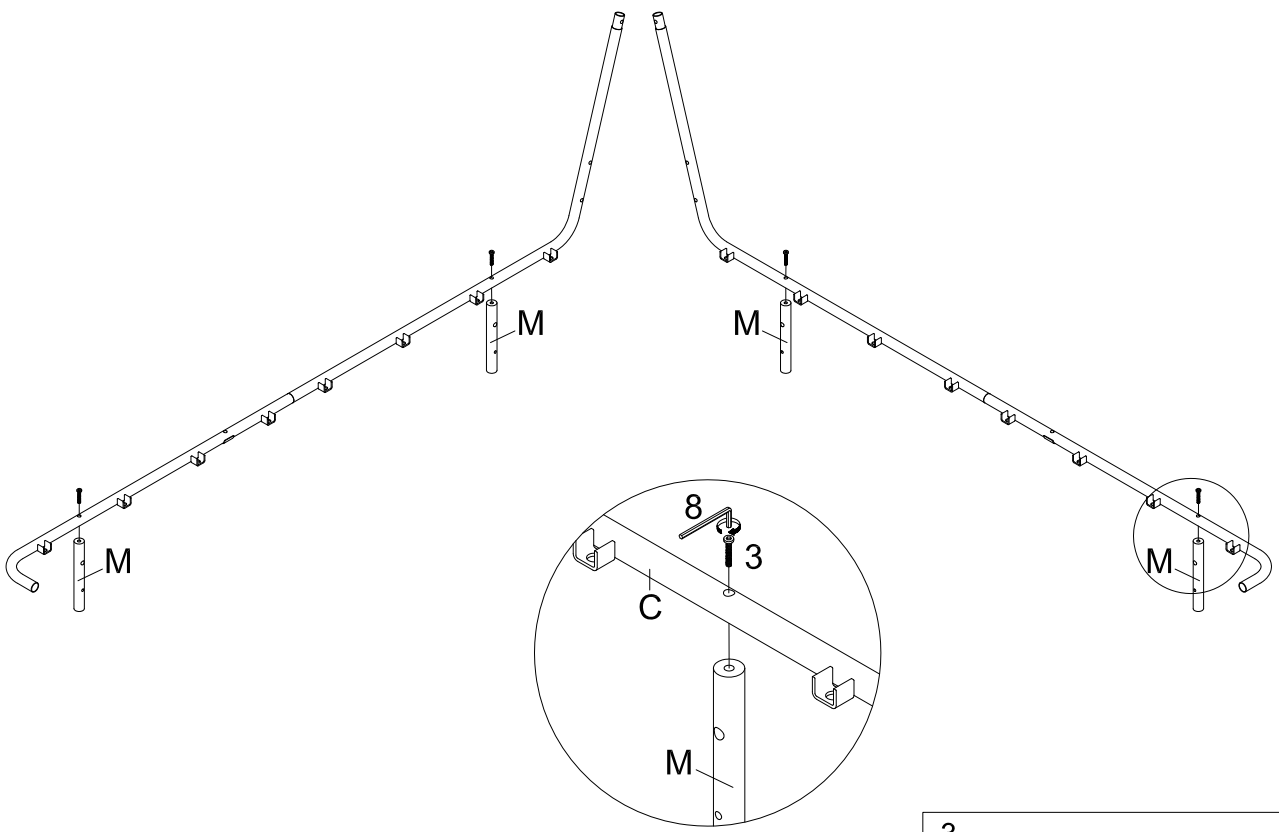

1		4pcs
M6x15		

STEP 2.



3		4pcs
M6x40		

STEP 3.

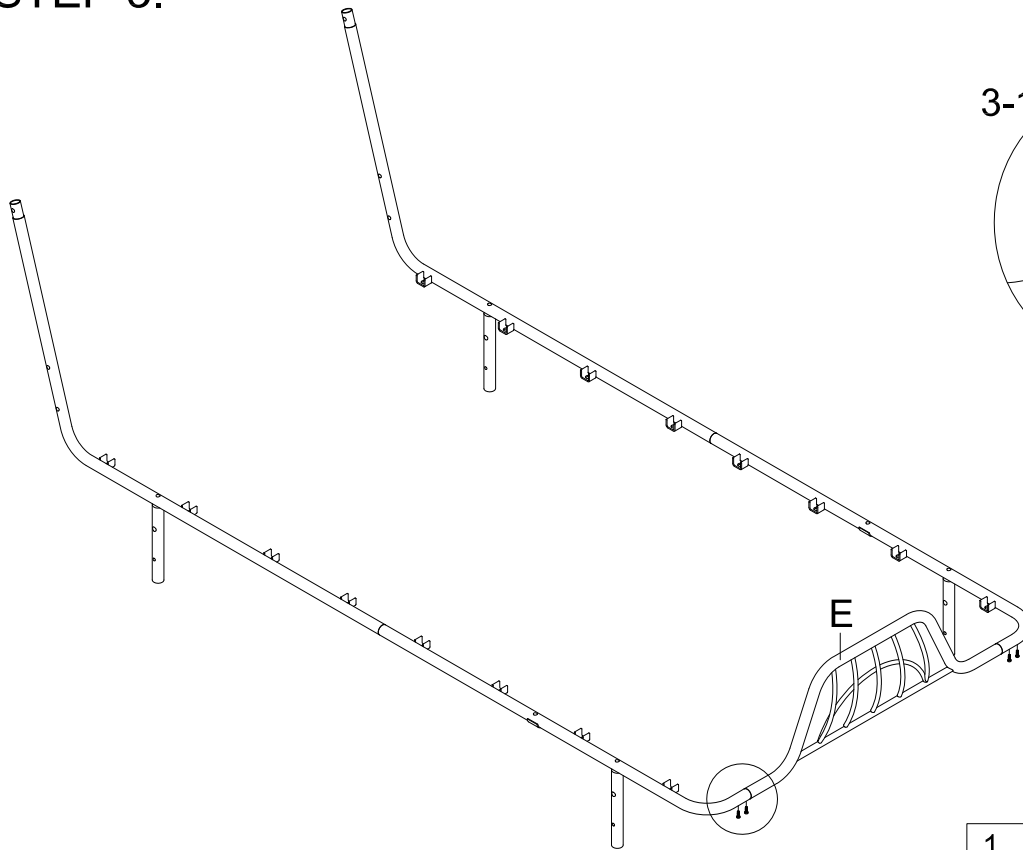

3-1

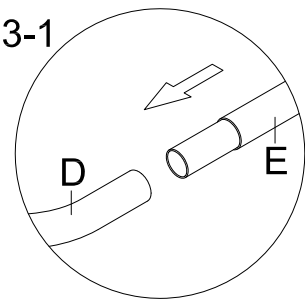

3-2

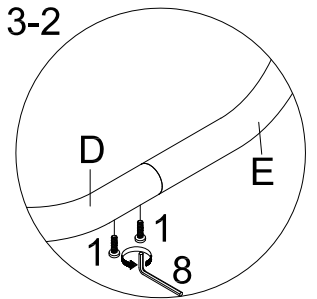

1

M6x15



4pcs

STEP 4.

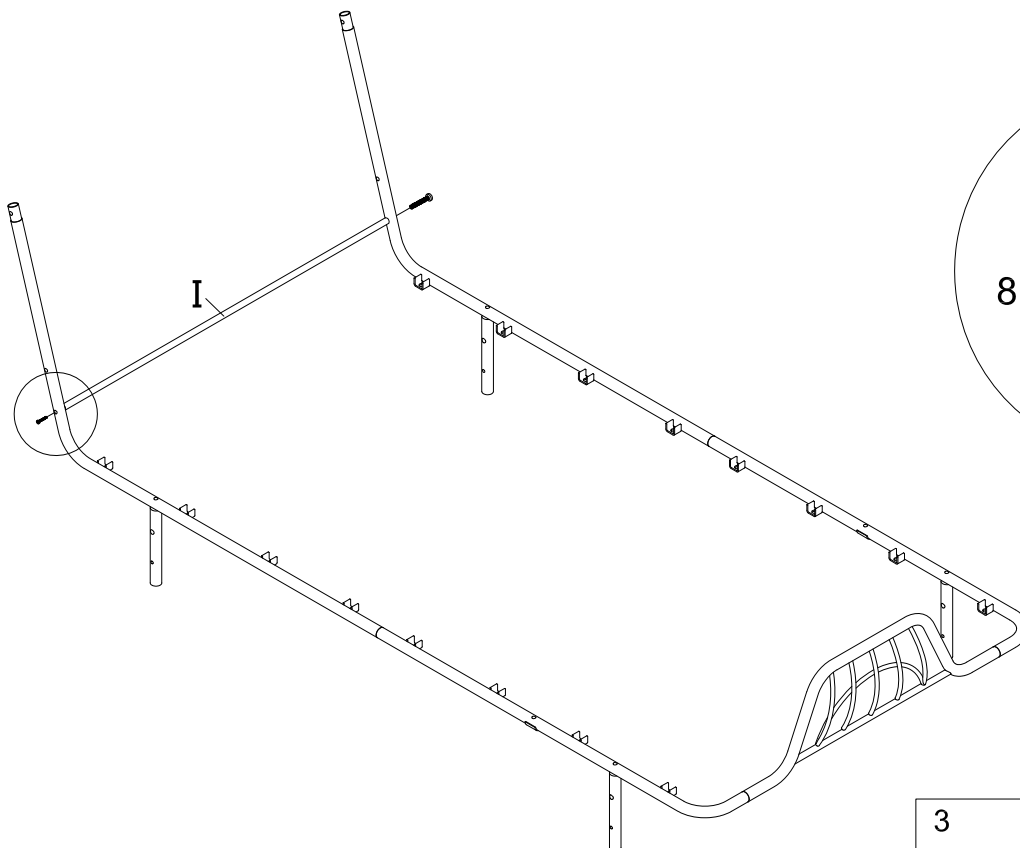

3

M6x40



2pcs

STEP 5.

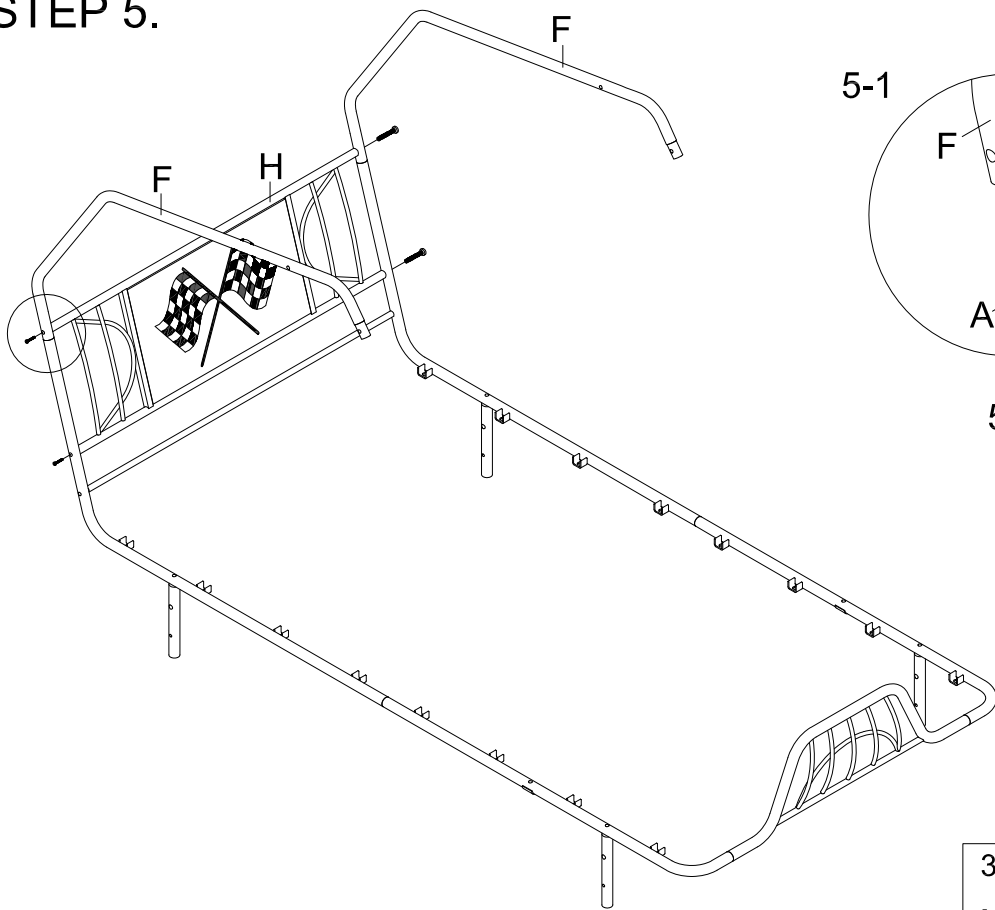

5-1

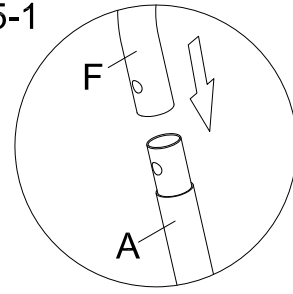

5-2

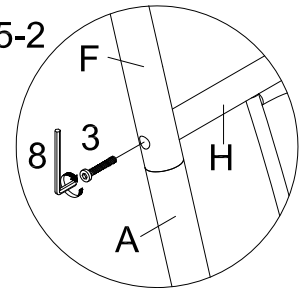

3

M6x40



4pcs

STEP 6.

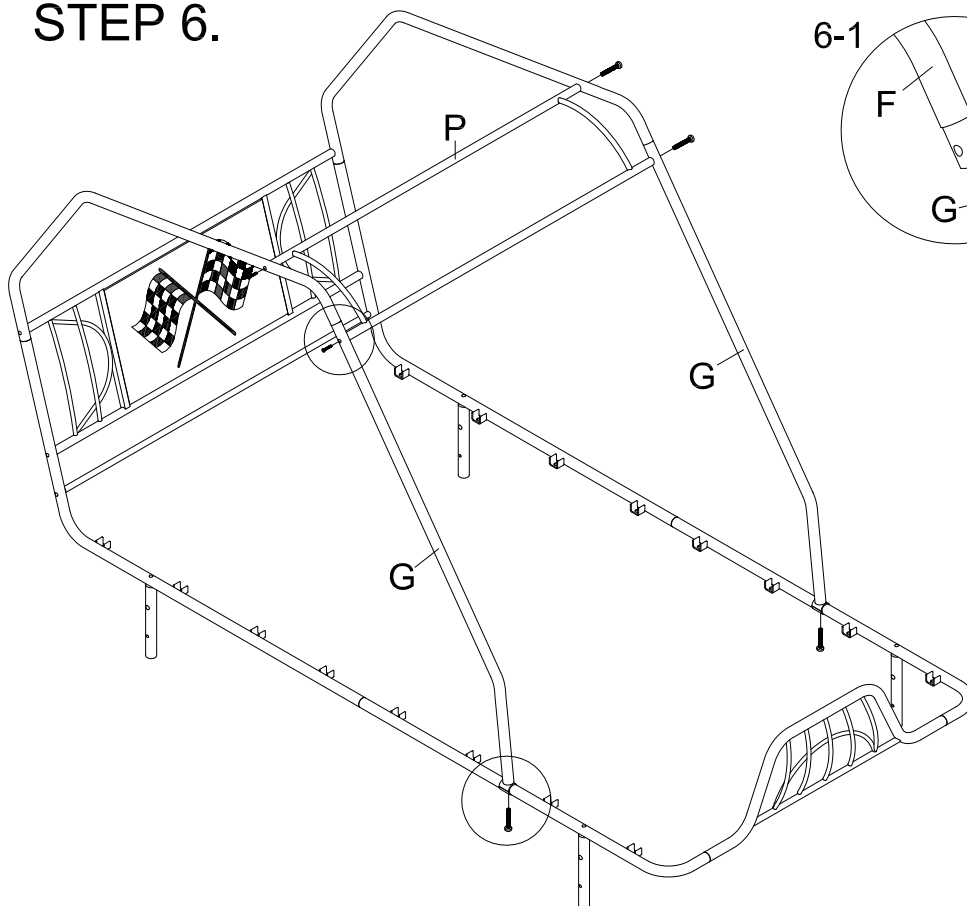

6-1

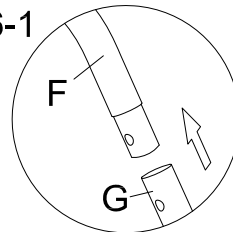

6-2

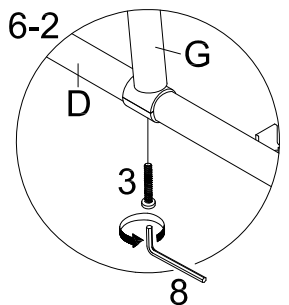

6-3

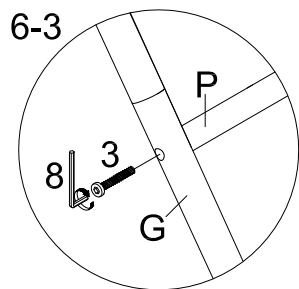

3



M6x40

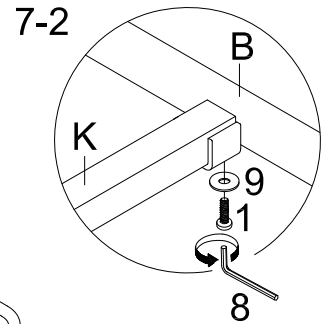
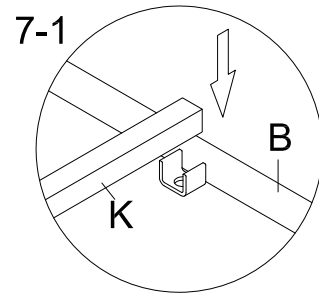
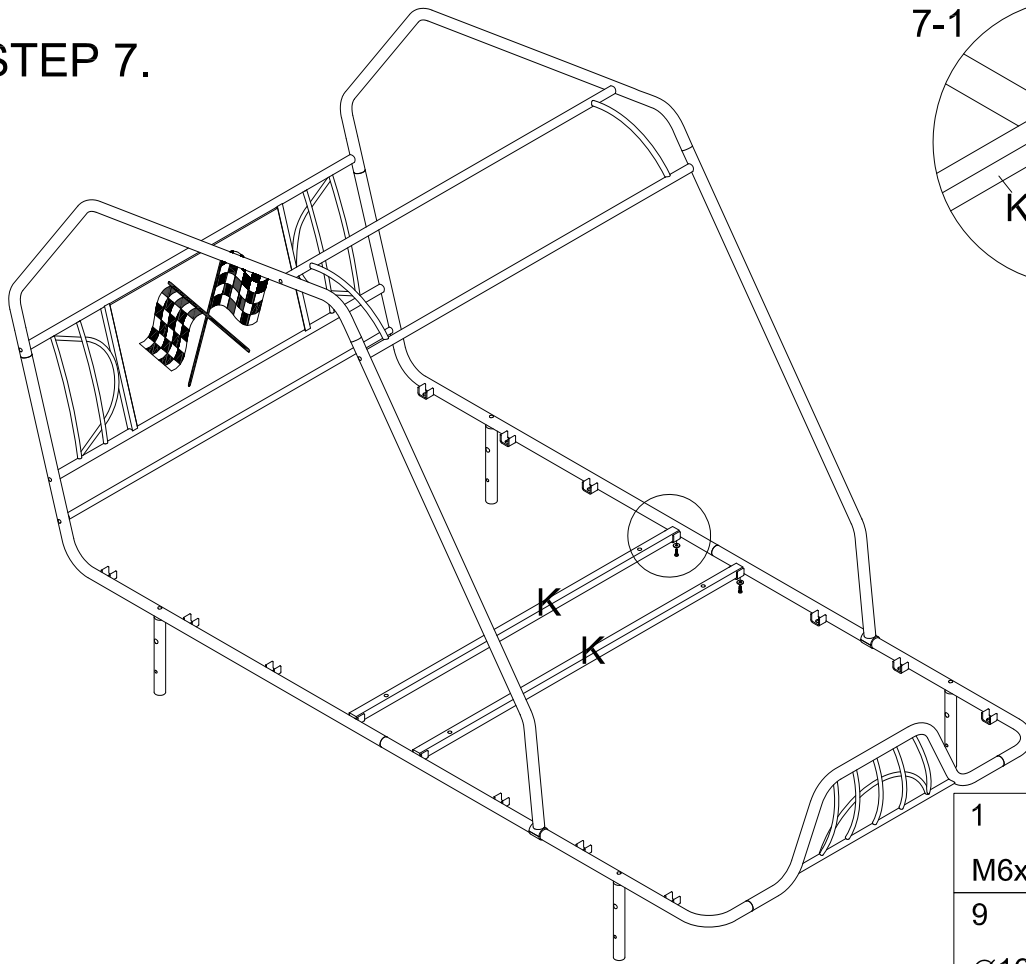

6pcs

STEP 7.



1		4pcs
M6x15		
9		4pcs
Ø16xØ7x1.0		

STEP 8.

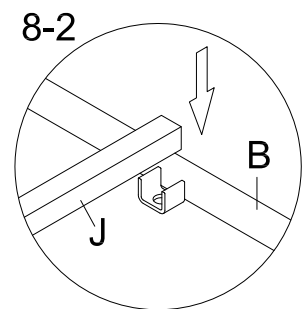
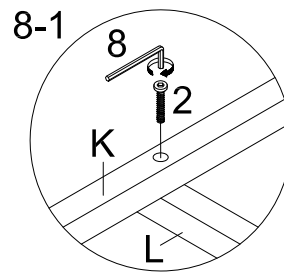
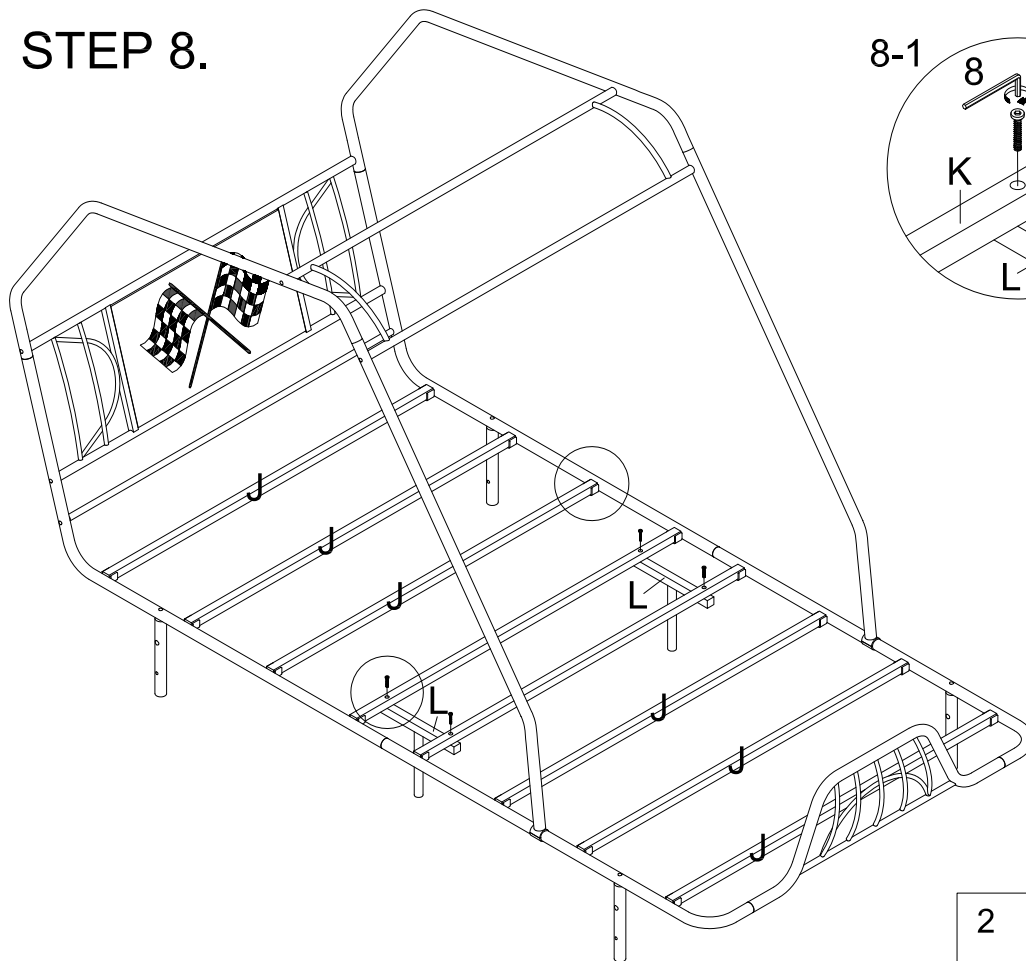

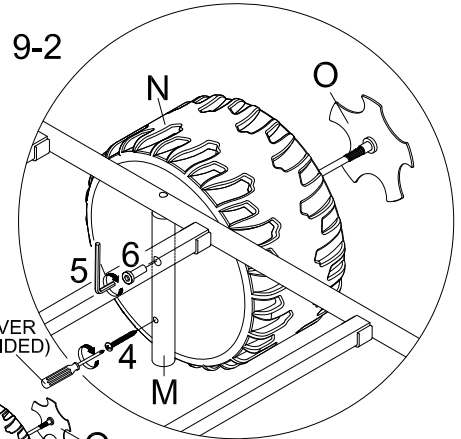
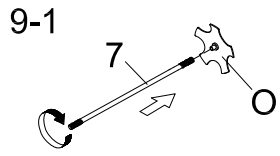
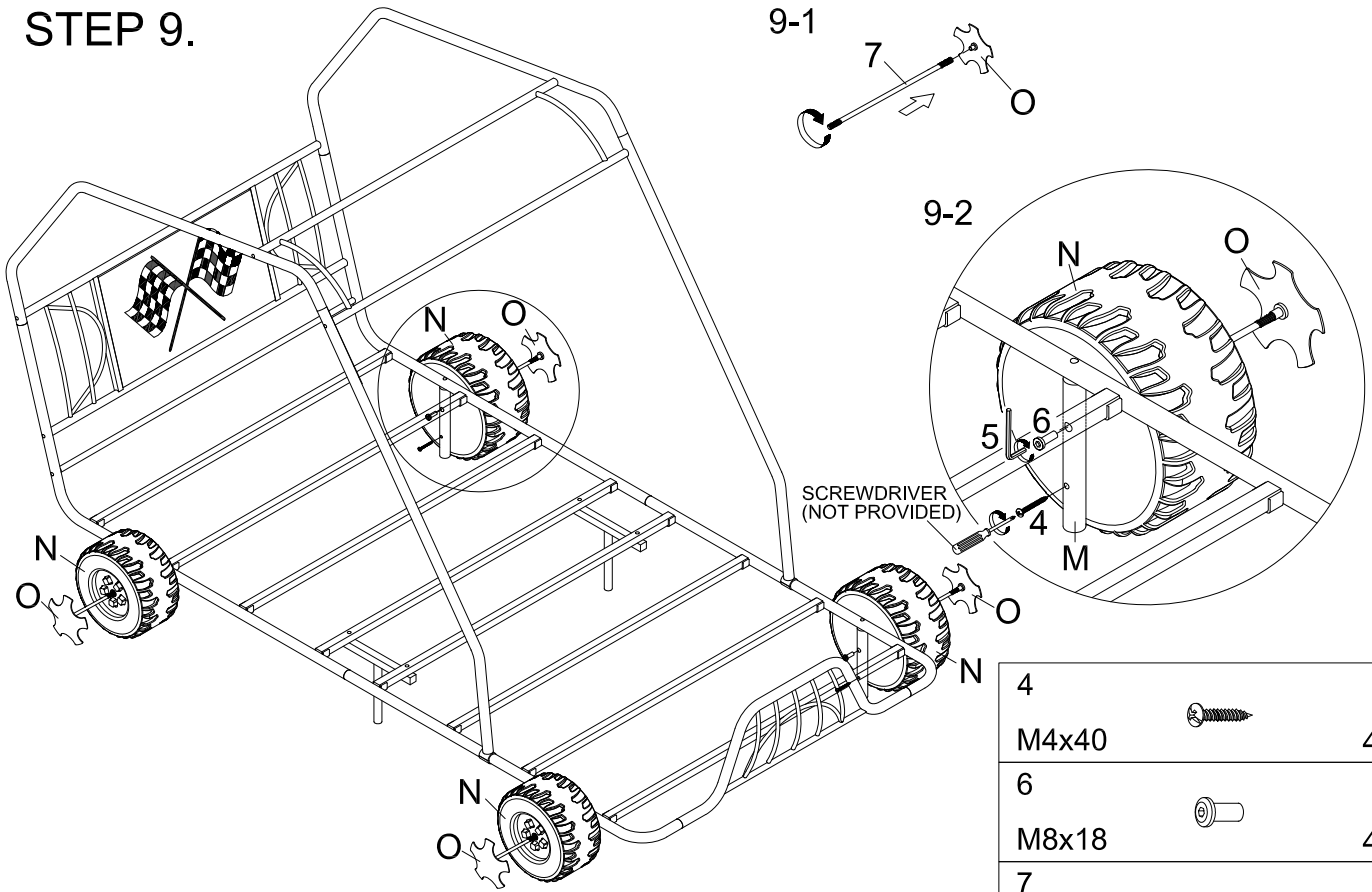

2		4pcs
M6x30		

STEP 9.

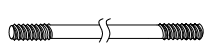

SCREWDRIVER
(NOT PROVIDED)

4		4pcs
M4x40		
6		4pcs
M8x18		
7		4pcs
M8x195		

STEP 10.

