



**ITEM NO. SCHD1539**

Scan for manual,  
video & advice.



If you have any questions or concerns,  
don't hesitate to reach out to us.

Call us: +1(833)324-2464 (8 AM to 5 PM PST Monday-Friday)  
Email: [customerservice@hulalahome.com](mailto:customerservice@hulalahome.com)

# MAINTENANCE AND WARNINGS

*Thank You For Choosing Our Furniture.*

*Please read the instructions and warnings carefully before use, to ensure safe and satisfactory operation of this product.*

## NOTE :

This brochure contains IMPORTANT safety info. Please read and keep it for future reference.



Weight Limit  
**200 LBS**

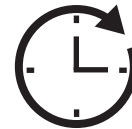

Installation:  
**20 minutes.**







**Two Person**



## Before You Start

*Please follow the steps below:*

-  Unbox the package and check if all parts and accessories are complete.
-  If you find something missing, stop assembly and contact your supplier immediately.
-  Please do not completely tighten all the hardware until the entire assembly is completed! Be sure to tighten all the hardware once the assembly completed.
-  NOTE: Should be assembled on soft surface to keep balance.

## *After-Sales Service*

- If you encounter any issues or need technical support during use, please contact our after-sales team. We offer long-term maintenance and warranty services.



## Warranty

- ⚠ We strive to offer high , quality products, and we also try our best to satisfy each and every customer that orders from us with product or service as needed. Each customer must provide a record of their order such as the order number, or item receipt for any items that are out of the warranty period you may also still receive replacement parts by purchasing them with our company if they are available.
- ⚠ Are you having difficulty with assembly? Missing parts? Please send email with your order number to [customerservice@hulalahome.com](mailto:customerservice@hulalahome.com)
- ⚠ For return, please check the return policy with the retailer or market place you bought from. Appreciate your purchasing from us. Pop up your life by our furniture piece!

### ***Daily Maintenance***

- Keep furniture away from heat.
- Do not use cleaning agents containing acids, alkalis, or corrosive substances, as they may damage the surface. It is recommended to use neutral cleaning agents or specialized furniture cleaners.
- Do not place furniture under direct sunlight, material will possibly fade over time.
- Do not use on site dry cleaning machine.
- Children should not climb or jump on the furniture.
- Do not write on furniture without a padded barrier to protect the surface.
- Not for commercial use, for residential use only.

# Exploded Diagram

Please confirm that you have received all the parts in the box and start the installation.

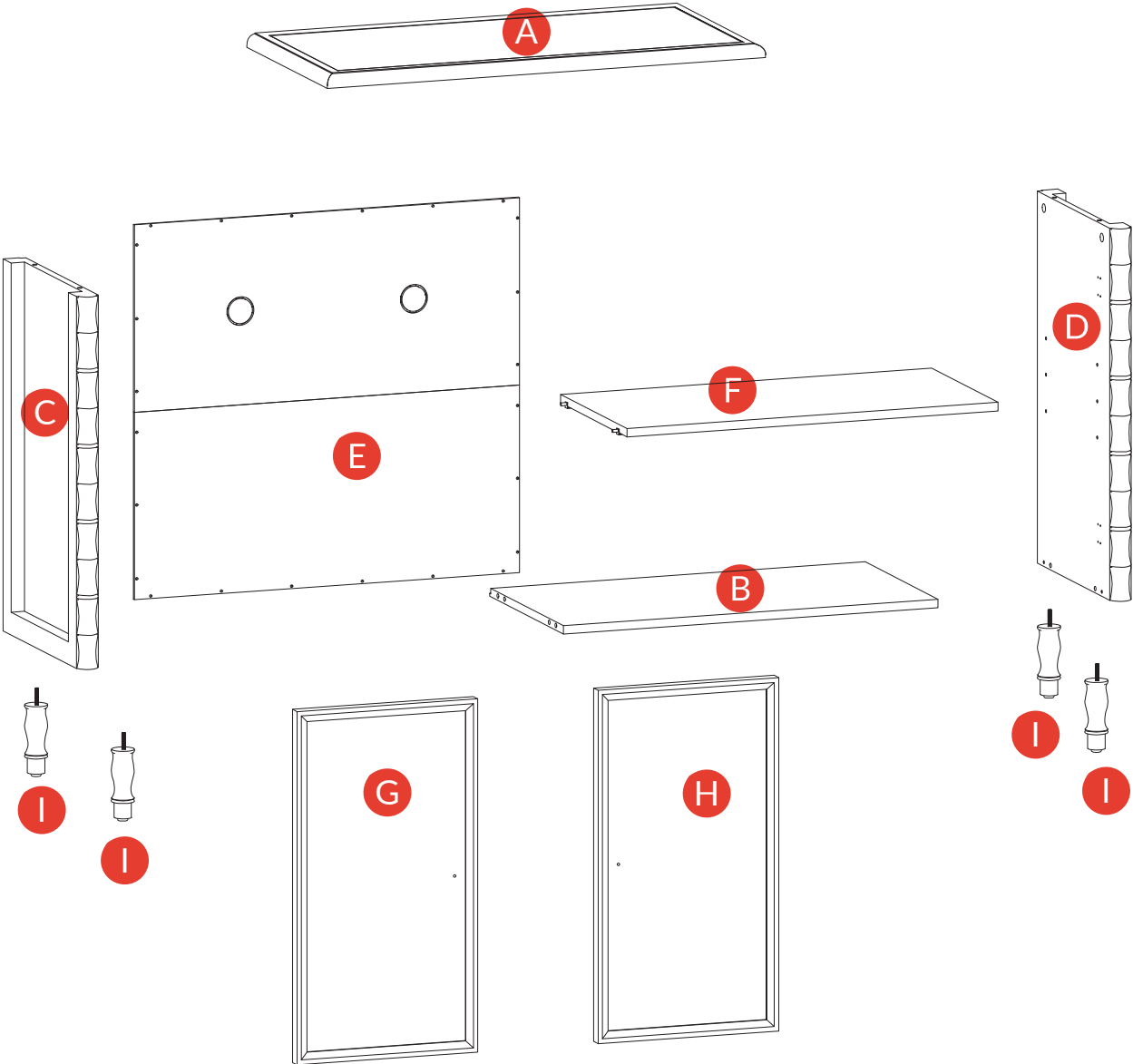

# Parts List

**A** x1



Panel

**B** x1



Baseplate

**C** x1



Left side panel

**D** x1

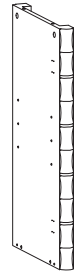

Right side panel

**E** x1

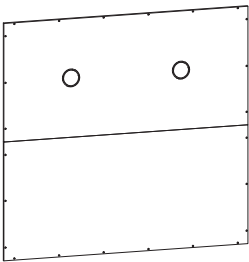

back panel

**F** x1



shelf board

**G** x1

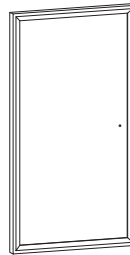

Left door panel

**H** x1

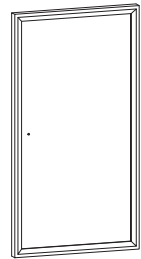

Right door panel

**I** x4



Legs

# Hardware List

1 x4

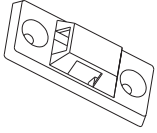

Anti-tip component

2 x4

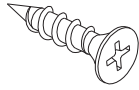

Self-tapping screw

3 x2

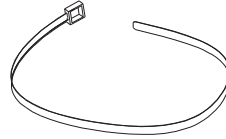

Hardware pack

4 x4

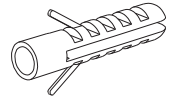

Expansion pipe  
L30mm

5 x4

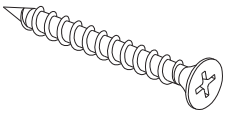

Self-tapping screw  
D4\*40

6 x1

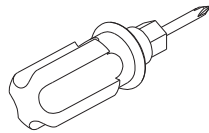

Screwdriver

7 x8+1

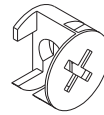

Expansion pipe

8 x8+1

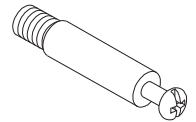

three in one  
M6x35mm

9 x8+1



tree top  
Ø8\*30

10 x1



door stopper

11 x4

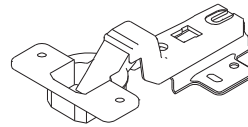

Internal clamp door hinge  
Ø35 mm

12 x4

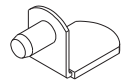

Layer board support

13 x24+3

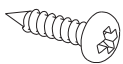

Self-tapping screw  
D4\*16mm

14 x24+3

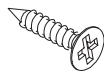

Self-tapping screw  
D4x16mm

15 x2+1

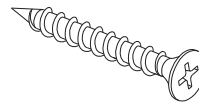

Direct repair screw  
D4x35mm

16 x4+2



Huamei Patch

17 x2



Hold hands

18 x2+1

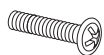



Pull screw  
D4x18mm

# ASSEMBLY INSTRUCTIONS

## Step 01

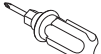
As shown in the figure: Insert the 3-in-1 rod (8) into the hole corresponding to the side plate (C/D). Lock with screwdriver (6) Load the tree top (9) into the hole corresponding to the side (C/D)

8	 x 4	M6x35	6	 x 1	Screwdriver
9	 x 4	Ø8x35mm			

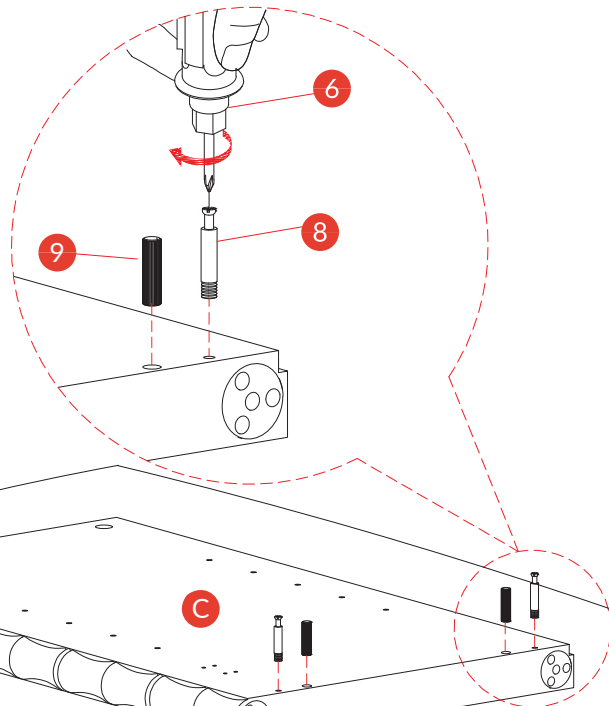
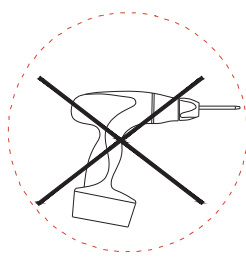
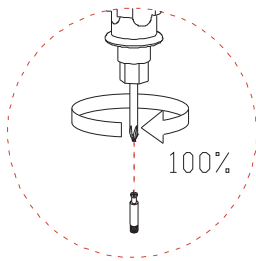

## Step 02

As shown in the figure: put the eccentric wheel (7) into the hole corresponding to the bottom plate (B), and lock it with a screwdriver (6).

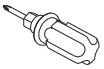
7		x 4	Expansion pipe
6		x 1	Screwdriver

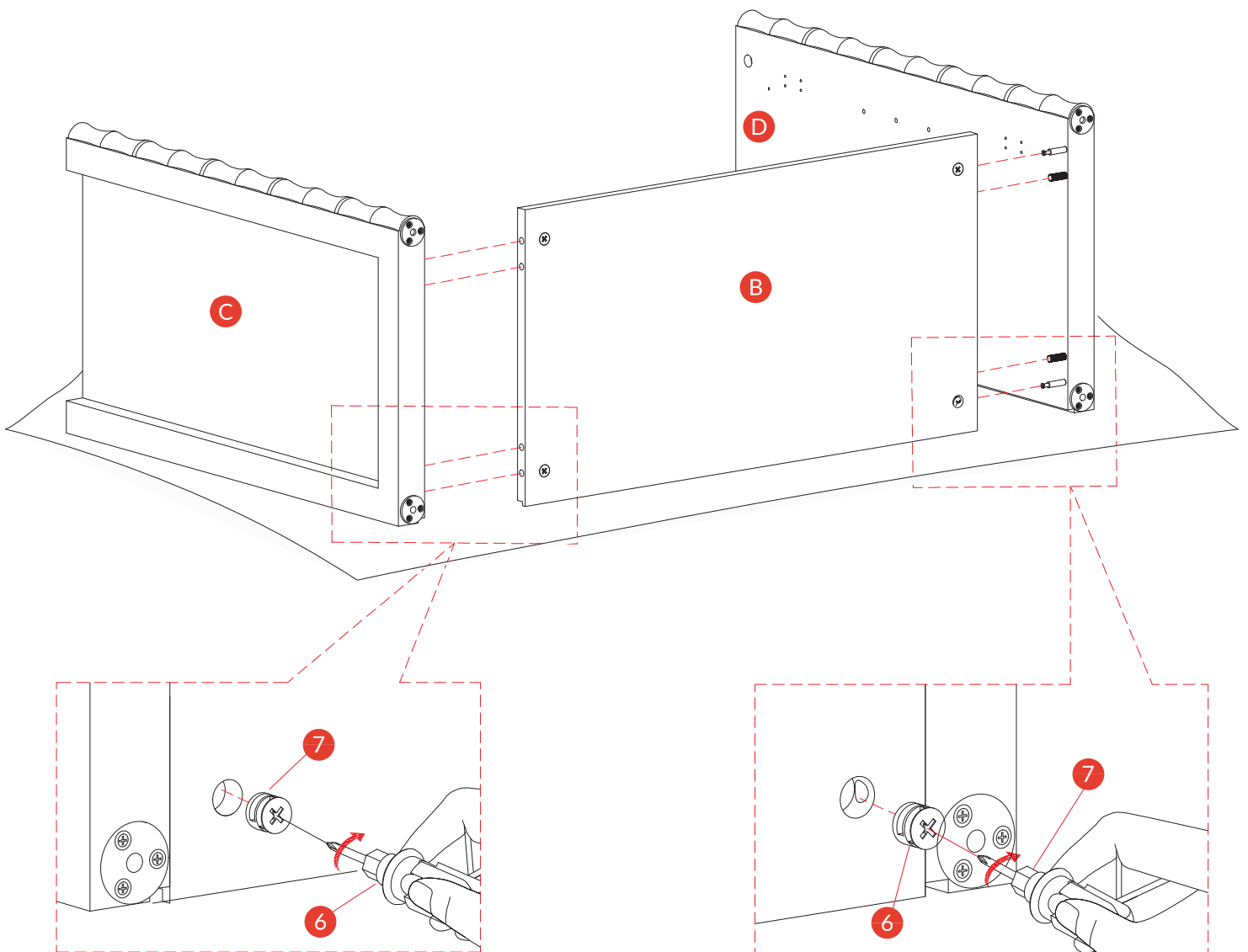

## Step 03

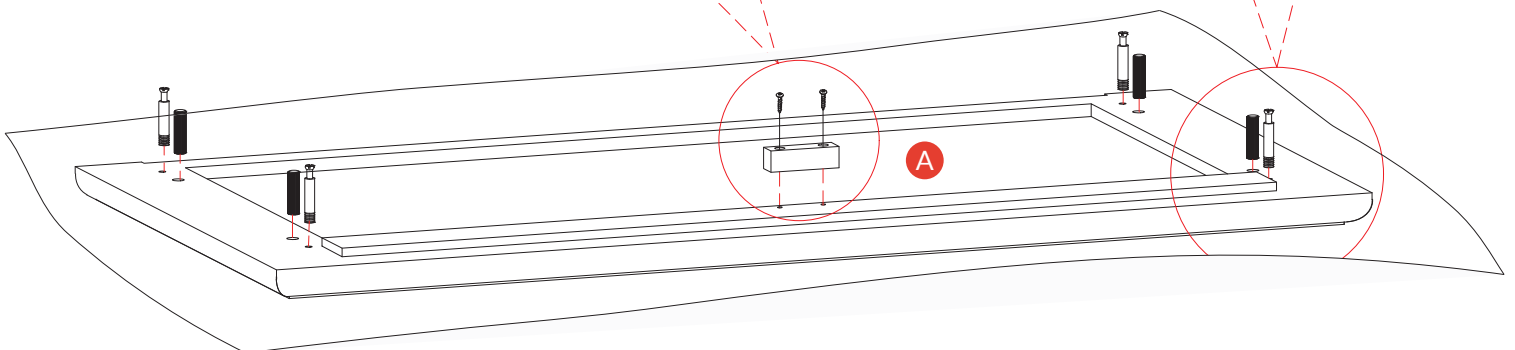
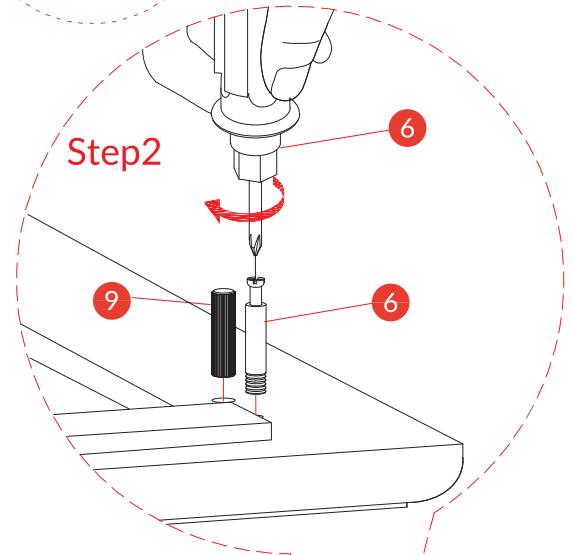
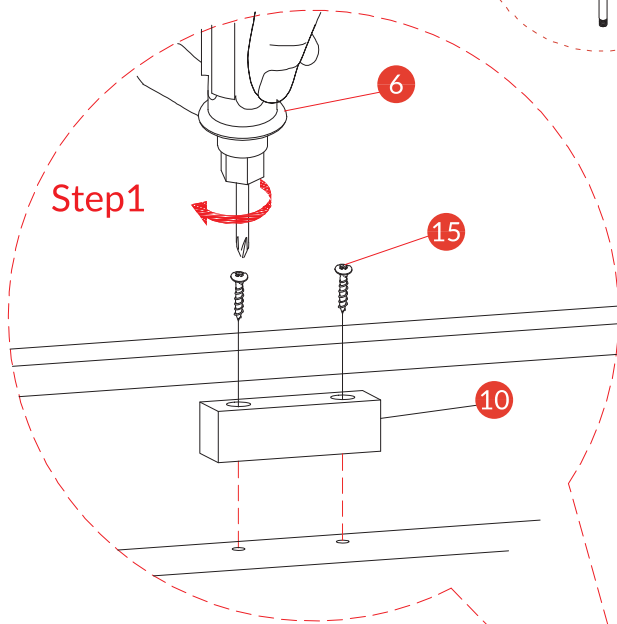
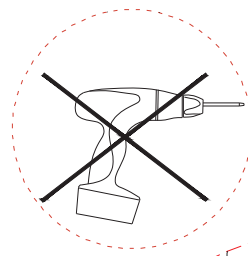
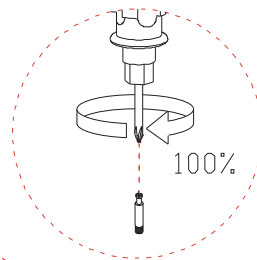

As shown in the figure: Screw (15) is inserted into the hole corresponding to the roof plate (A) through the wooden door stall (10), and locked with a screwdriver (6). Install the tree top (9) into the hole corresponding to the roof plate (A). Put the 3-in-1 (8) into the hole corresponding to the top plate (A) and lock it with a screwdriver (6).

9	x 4	Ø6x30mm	10	x 1	door stopper
15	x 2	D4x35mm	8	x 4	Ø6x35mm
6	x 1	Screwdriver			



## Step 04

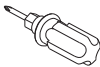

As shown in the figure: Install the eccentric wheel (7) into the hole corresponding to the side plate (C/D) and lock it with a screwdriver (6)  
Paste the masking sticker (16) to the hole corresponding to the side plate (C/D)

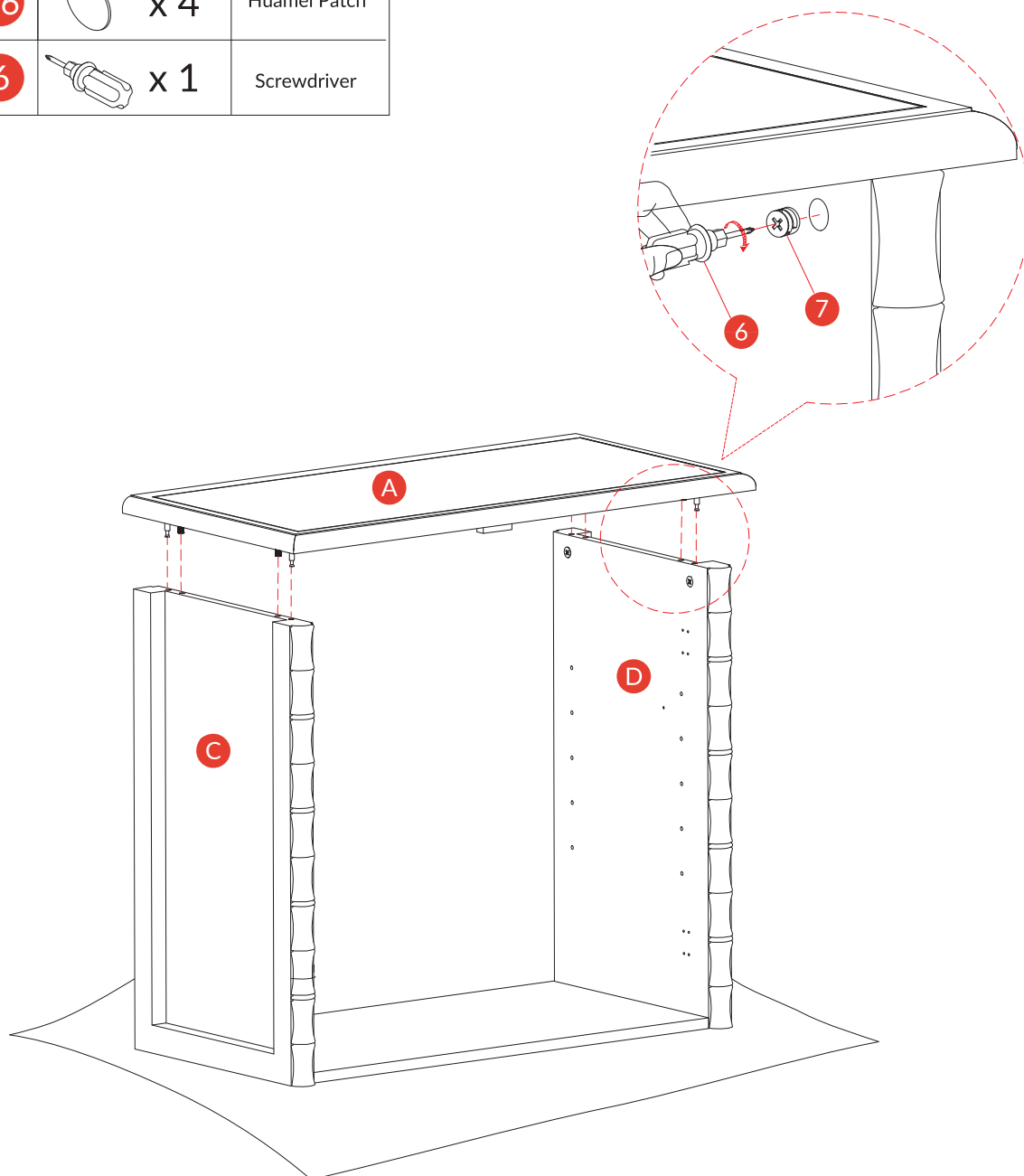
7		x 4	Expansion pipe
16		x 4	Huamei Patch
6		x 1	Screwdriver



## Step 05

Open the back panel (E), place it into the slot on the back of the cabinet, insert the screws (13) through the corresponding holes on the back panel, and tighten them with the screwdriver (6).

13	 x 24	D3x16mm
6	 x 1	Screwdriver

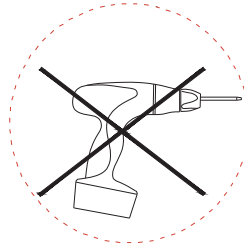
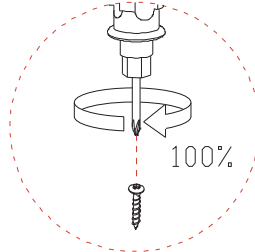

Step1

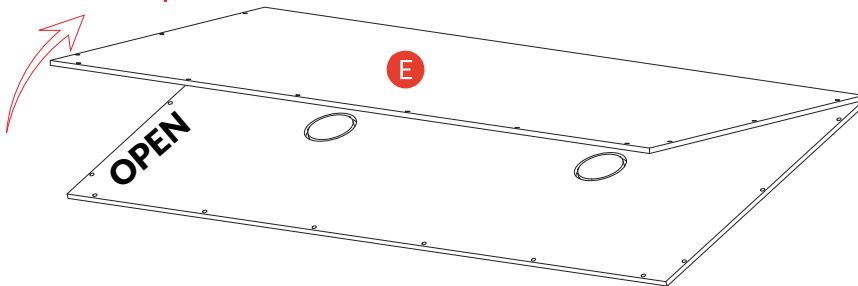

Step2

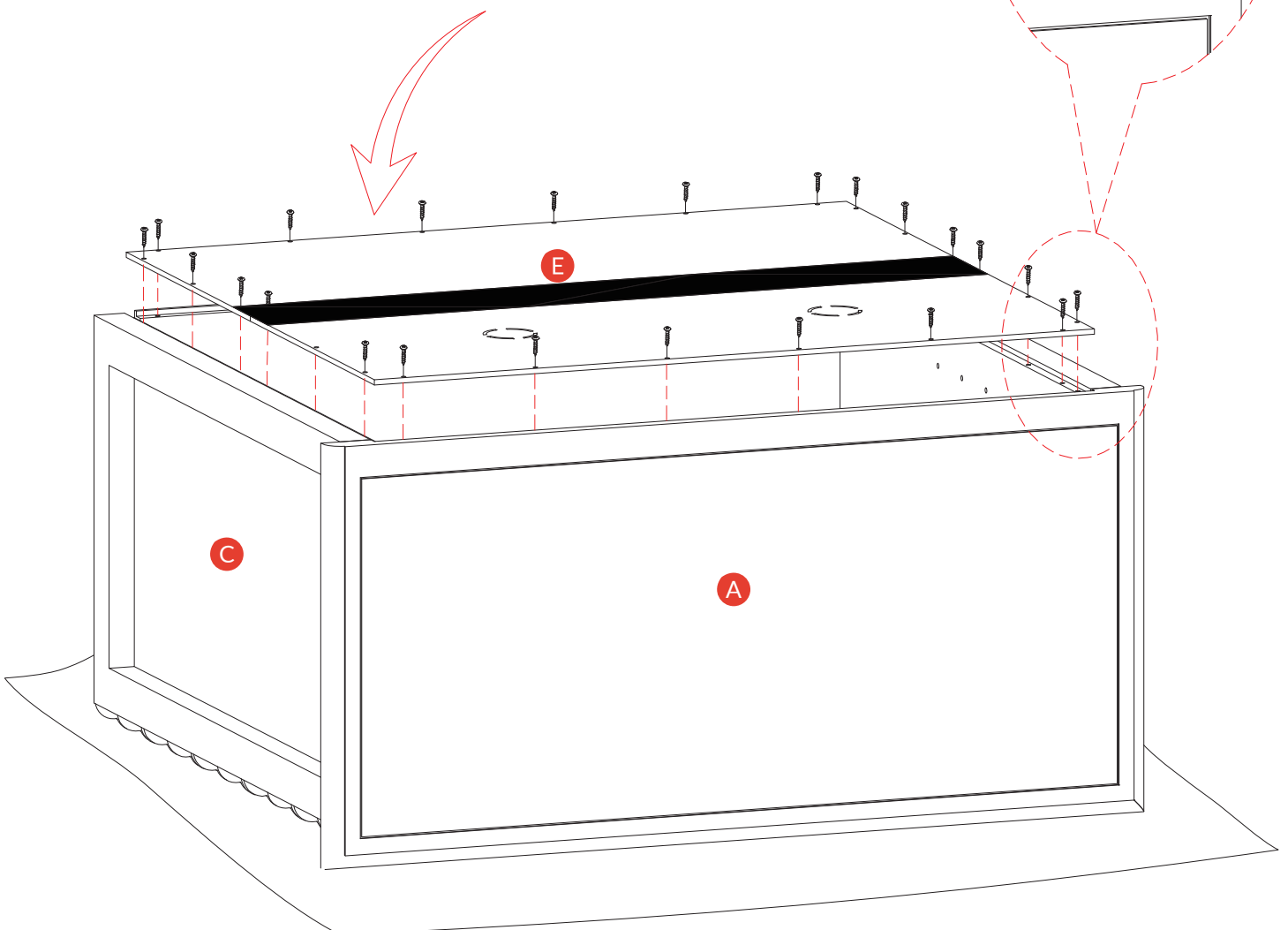
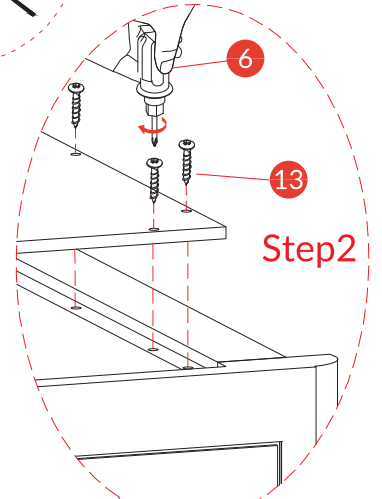

## Step 06

As shown in the figure: Put the foot (I) into the corresponding hole of the assembled cabinet.

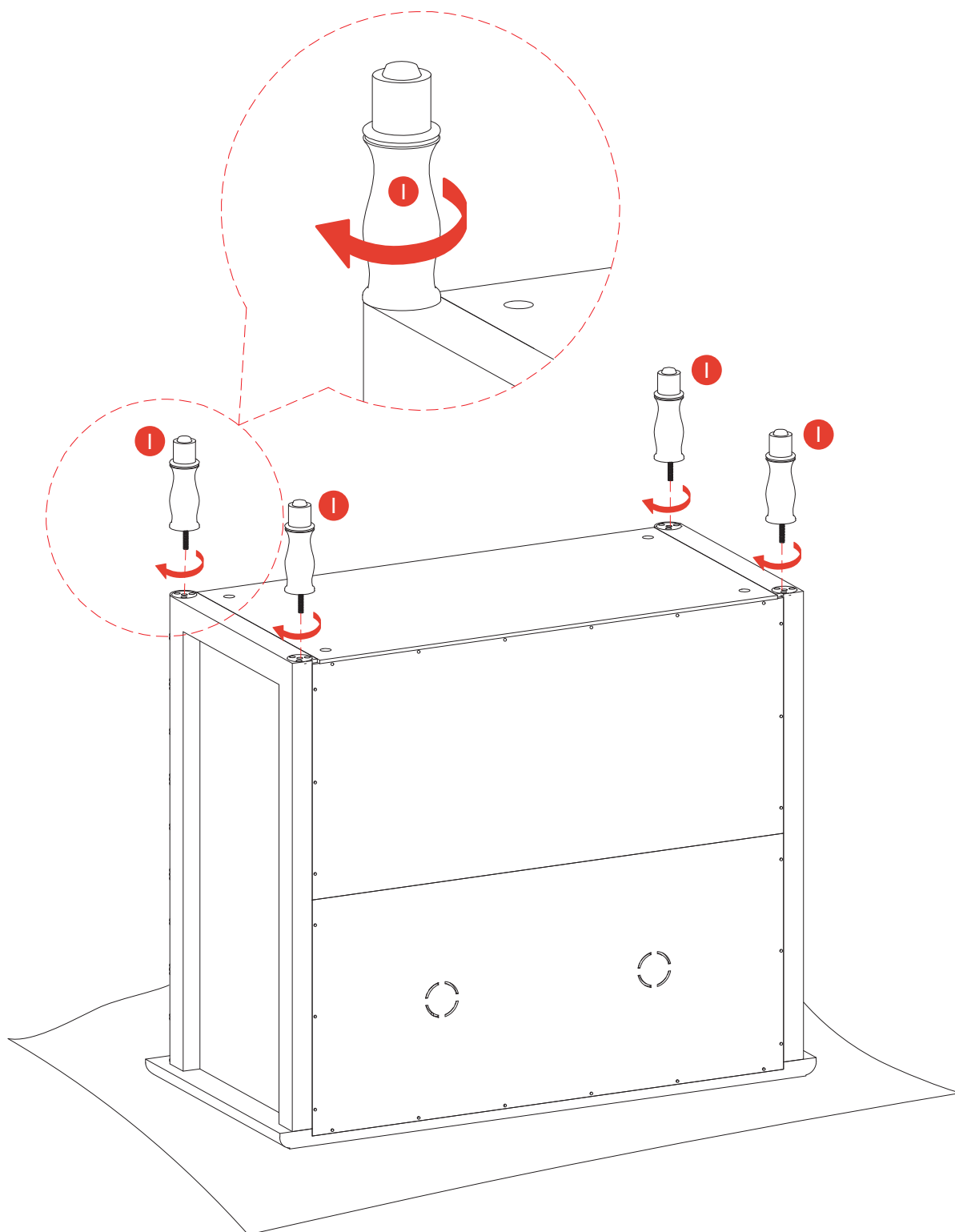

## Step 07

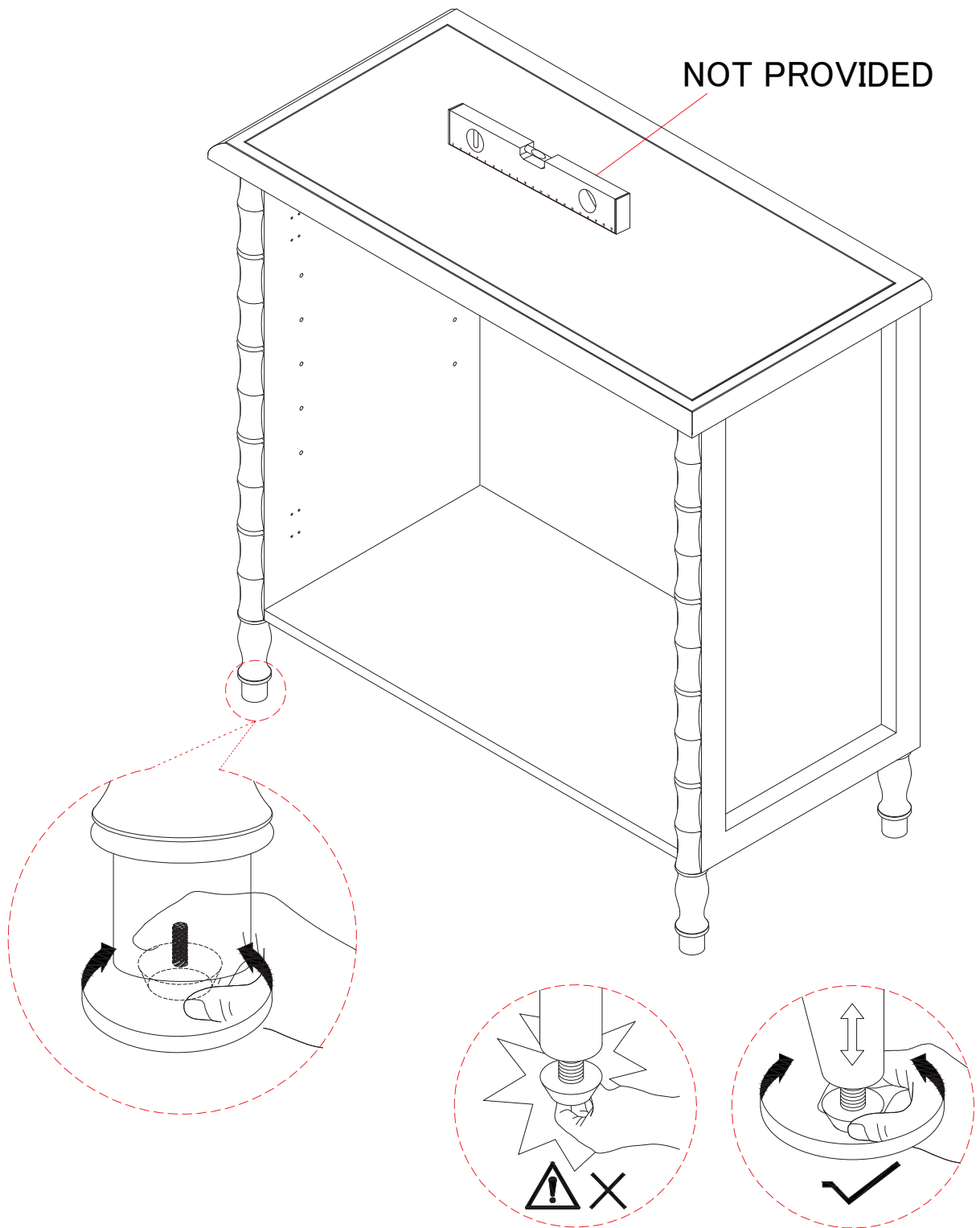



Note:  
Before the next step, adjust the feet of  
the locker to keep it level.



## Step 09

As shown in the figure: Install hinge (11) into the corresponding hole position of door (G/H). Screw (14) through the hole corresponding to the entrance (H) through hinge (11), and lock it with a screwdriver (6).

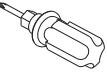

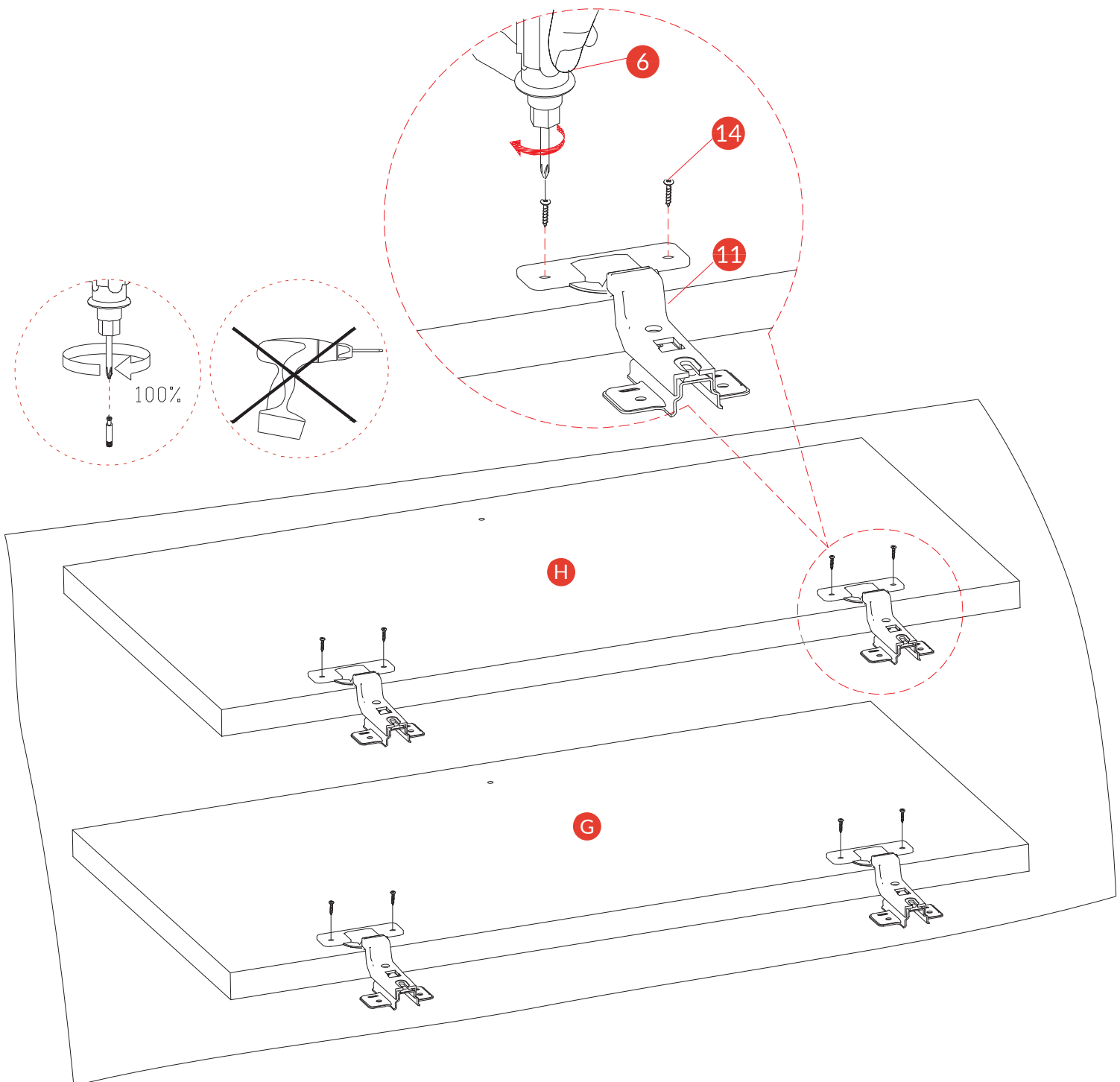
14	 x 8	D4x16mm	11	 x 4	Ø35 mm
6	 x 1	Screwdriver			



# Step 10

As shown in the figure: Put the door (G/H) into the corresponding hole of the cabinet and lock it with a screwdriver (6).

Insert the screw (18) through the door panel (G/H) into the corresponding hole of handle (17) and lock it with a screwdriver (6).

<b>14</b>	 x 16	D4x16mm	<b>17</b>	 x 2
<b>18</b>	 x 2	D4x18mm	<b>6</b>	 x 1

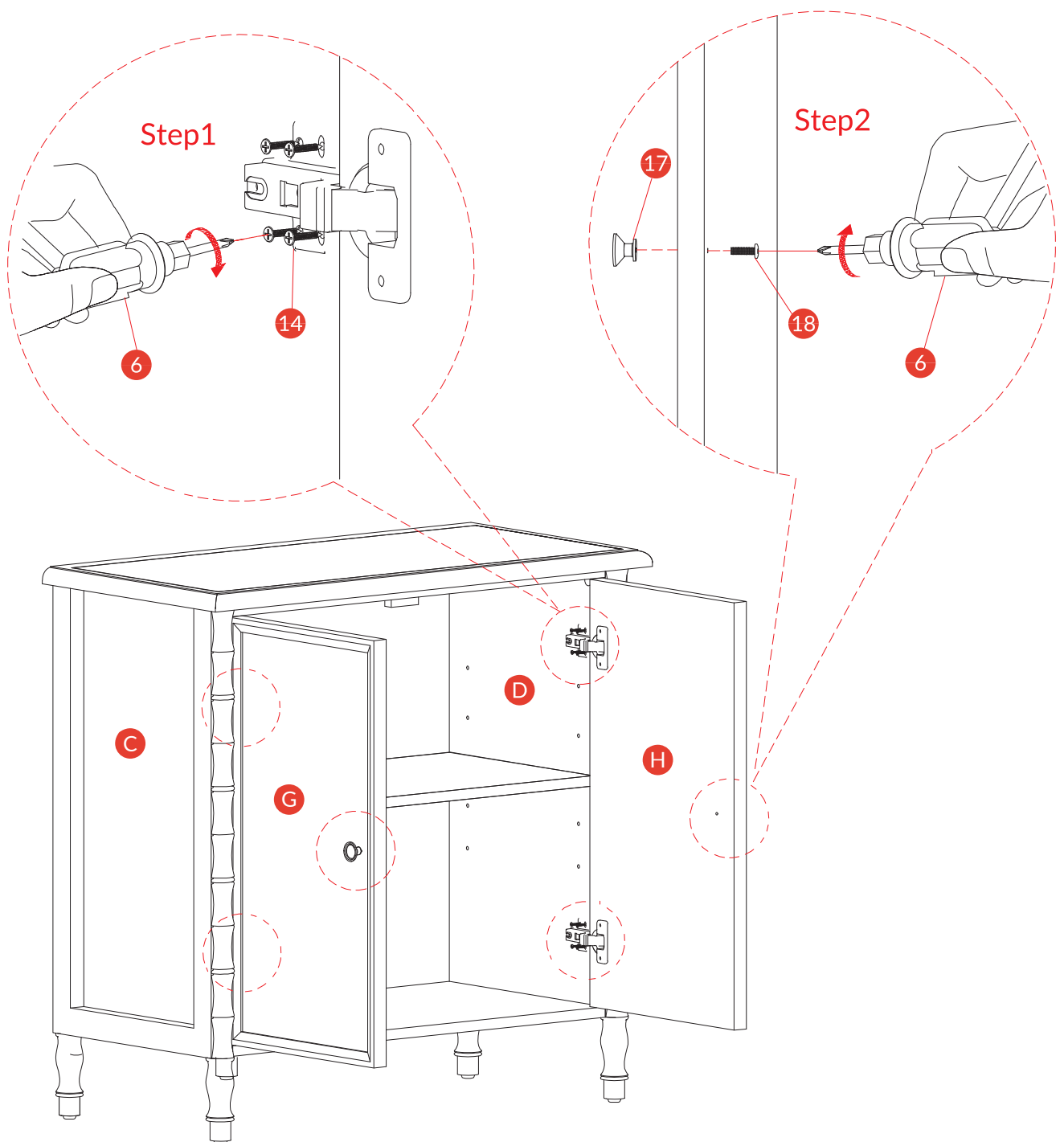

# Door Hinge Adjustment Instructions

Concealed hinges are three-way adjustable.

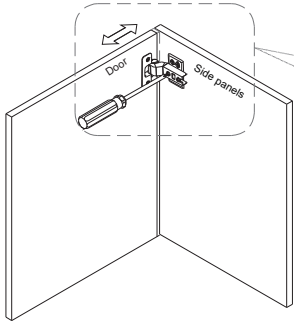

Horizontal by screw adjustment!

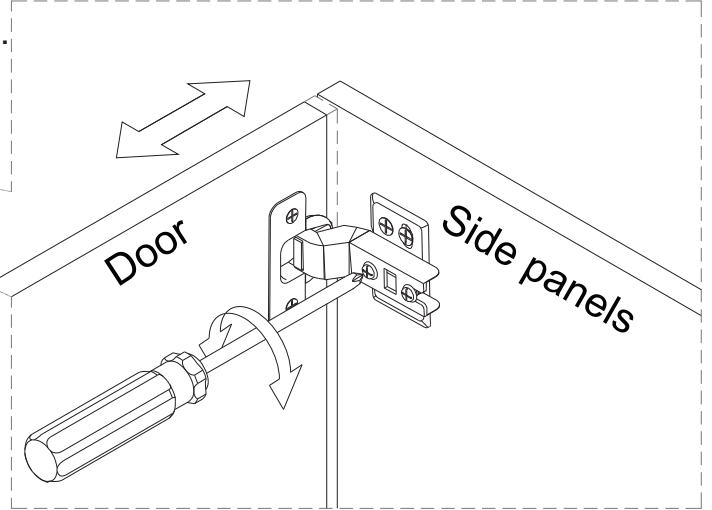

Concealed hinges are three-way adjustable.

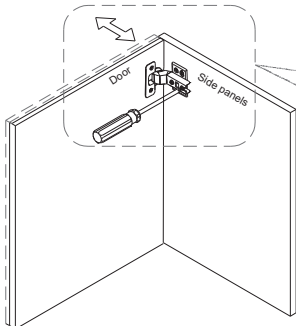

In-and-out by loosening the hinge arm mounting screw or via cam adjustment!

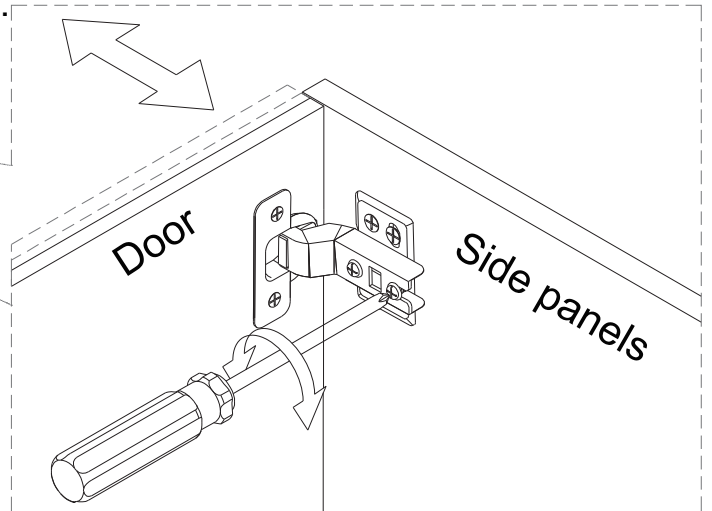

Concealed hinges are three-way adjustable.

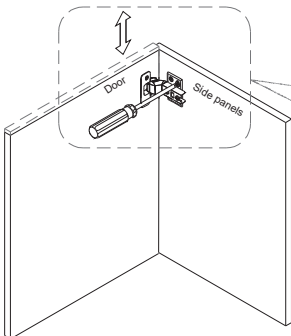

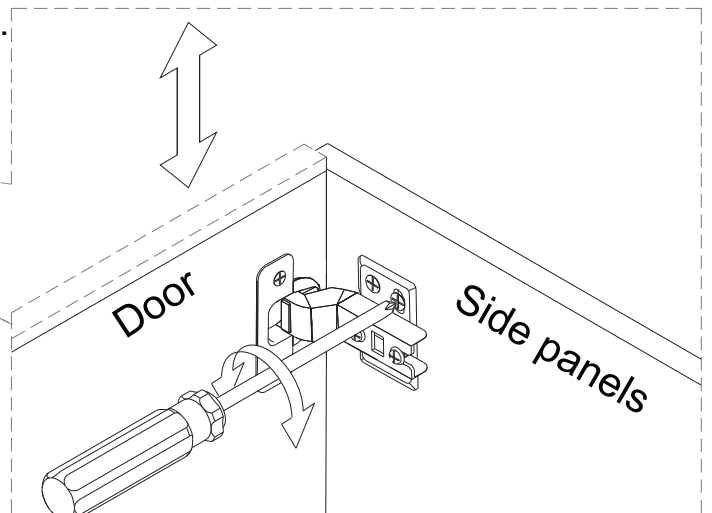

Vertical via slots in the mounting plate or via cam adjustment!



# Step 11

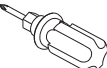

Pass screw (2) through the anti-tilt part (1) and attach it to the corresponding position on the cabinet panel (A), then tighten it with screwdriver (6).

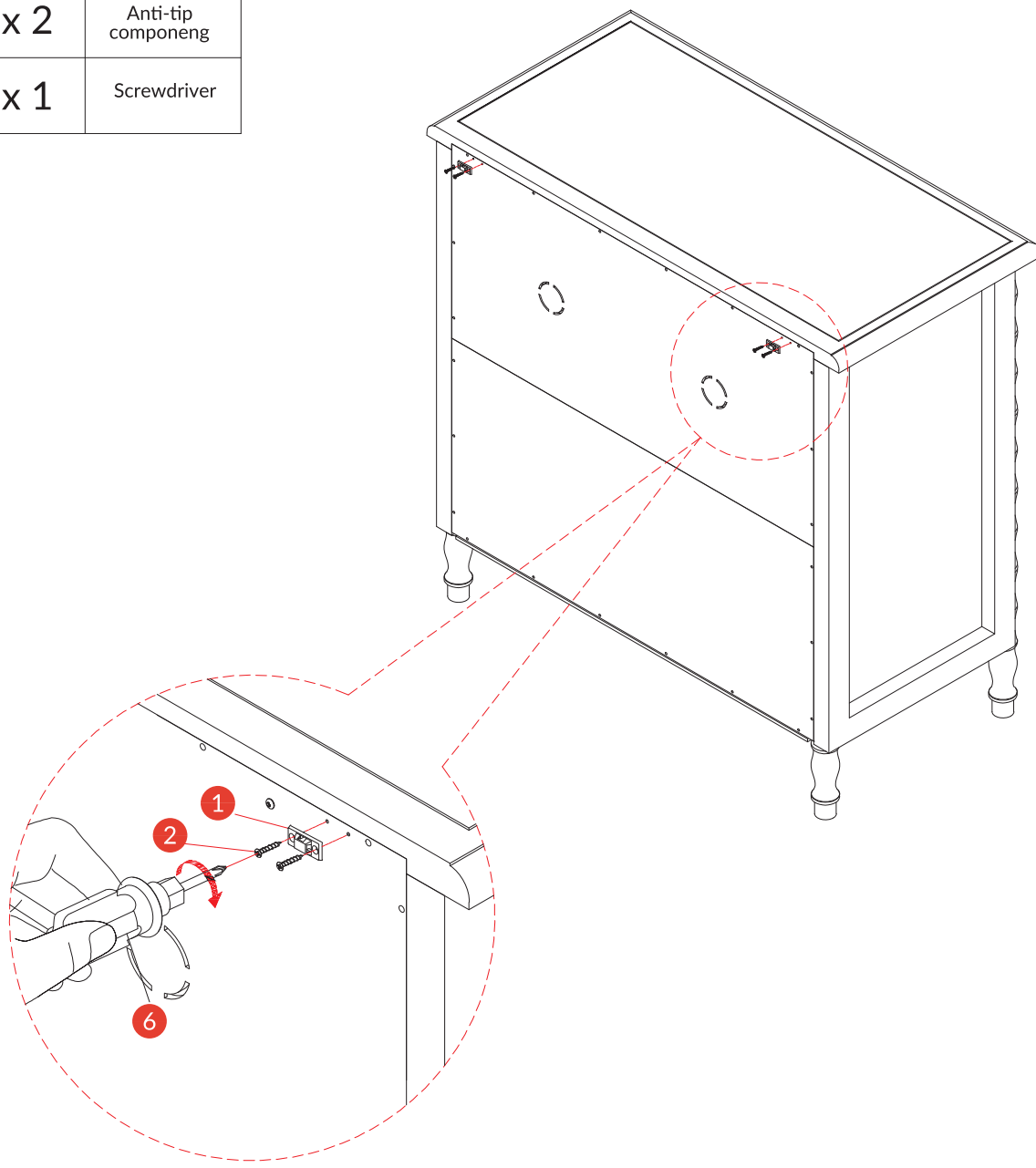
2	 x 4	D4x20mm
1	 x 2	Anti-tip componeng
6	 x 1	Screwdriver

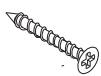

## Step 12

Install Anti-tip device (1) to the wall in this step.

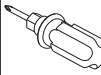
5	 x 4	D4x40mm	1	 x 2	Anti-tip componeng
4	 x 4	L30mm	6	 x 1	Screwdriver

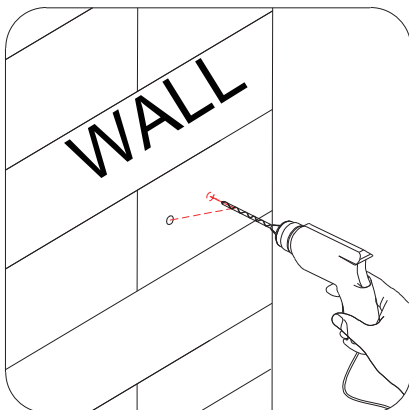
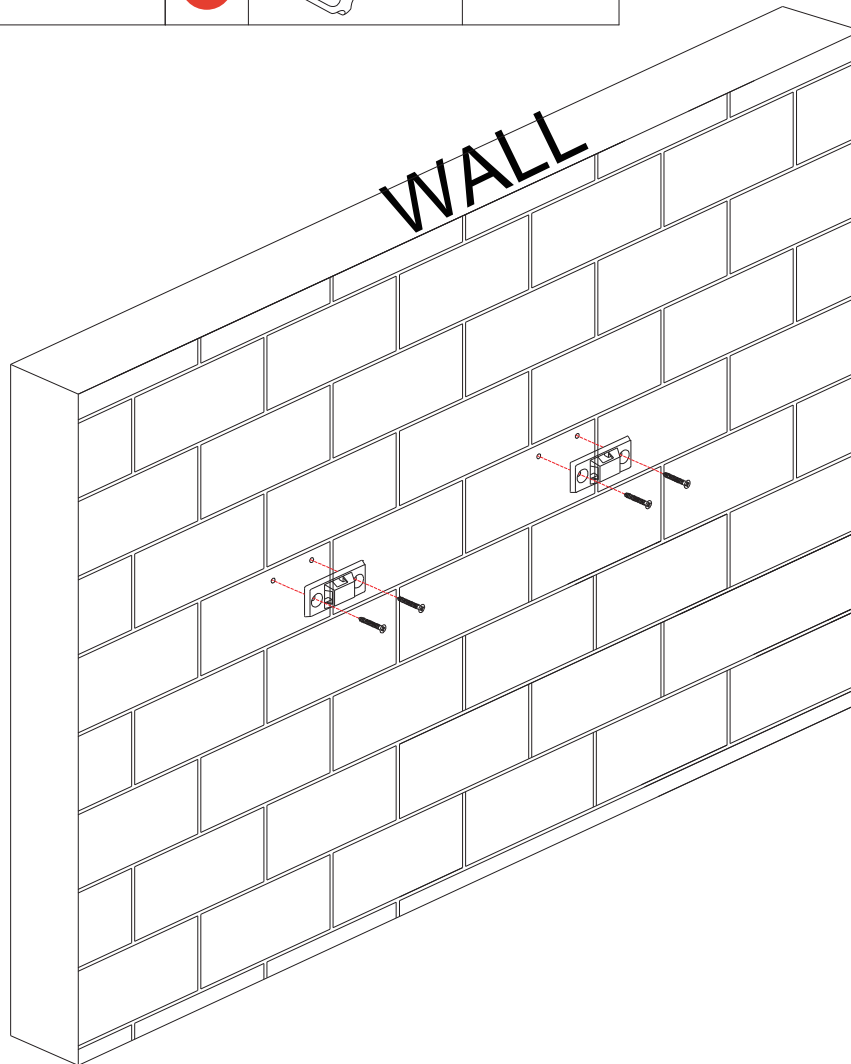

1. Drill a hole in the wall with an electric drill.

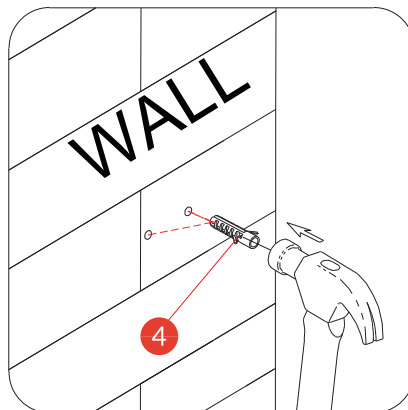

2. Tap the plastic wall anchor into the hole with a hammer.

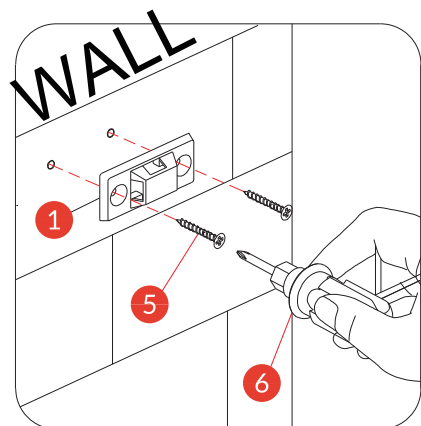

3. Secure the Anti-tip device 1 to the wall with screws 5.

## Step 13

### WARNING

**Children have died from furniture tipover.**

**To reduce the risk of furniture tipover:**

- ALWAYS install Anti-tip device provided.
- For use with televisions weighing 35 lb or less. Use with heavier televisions may result in instability causing tip-over resulting in death or serious injury.
- NEVER allow children to stand, climb or hang on drawers, doors, or shelves.
- NEVER open more than one drawer at a time.
- Place heaviest items in the lowest drawers.

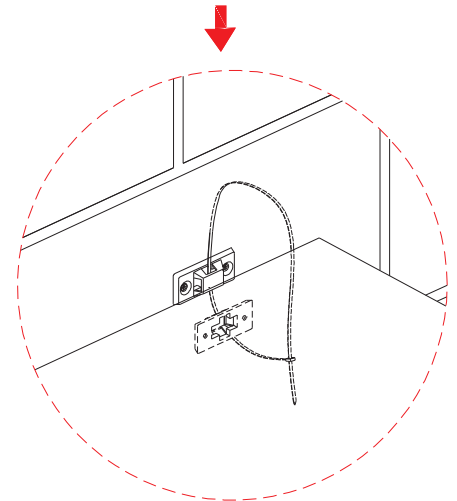
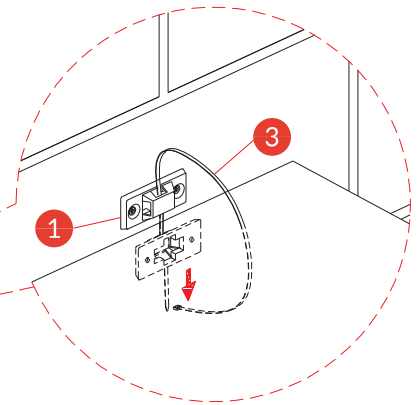
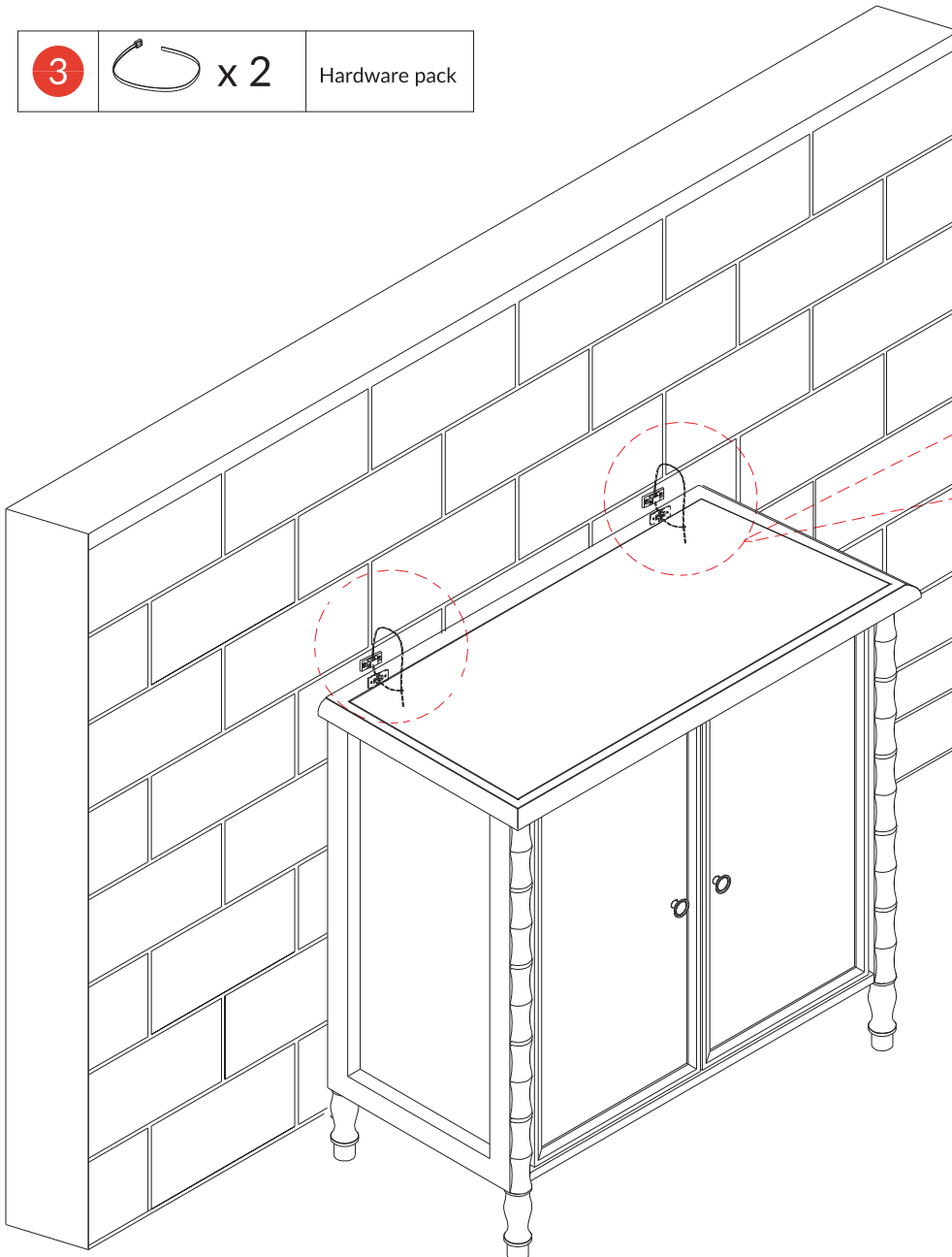
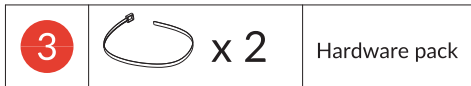

[WWW.HULALAHOME.COM](http://WWW.HULALAHOME.COM)

Email: [customerservice@hulalahome.com](mailto:customerservice@hulalahome.com)

Call us: +1(833)324-2464 (8 AM to 5 PM PST Monday-Friday)