

**PRODUCT GUIDE & ASSEMBLY INSTRUCTIONS**

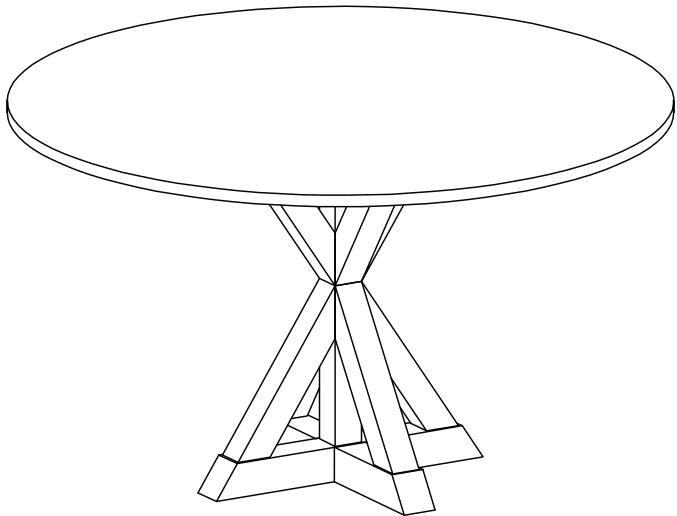

**Dining Table**

Should you prefer to speak with a customer service representative, you may call toll free

## **Guidelines**

**FAILURE TO FOLLOW THESE WARNINGS  
WHEN IN USE COULD RESULT IN INJURY**

- Do not stand on the item or use as a step ladder
- Do not use this item unless all bolts and screws are firmly secured and fastened.
- Check all bolts and screws every 90 days. As necessary tighten if any are loose.
- Lift up then move. Pushing over or dragging this product can result in an injury or cause damage to the floor and piece.

# **WARNING:**

**DO NOT LET CHILDREN PLAY IN OR AROUND THE UNIT DUE TO THE POSSIBLE RISK OF INJURY.**

## **Pre-Assembly Preparation:**

Please read through this instruction booklet before beginning assembly of this item.

## **Two adults are recommended for assembly.**

- Clear out the space for assembly and lay out all parts on Parts List, extra room will allow you to easily determine if all the pieces are present.
- Save all packing materials until assembly is complete to avoid accidentally discarding smaller parts or hardware.
- Keep small parts and pieces away from children and pets until fully assembled.
- Please check for any loose screws and tighten them before you use.

# Parts List



1 Table Top (1)



2 Table Leg (1)



3 Table Support (1)

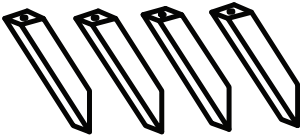

4 Leg Support (4)

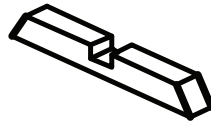

5 Leg Bottom (1)

# Parts List



(H1) Allen Key (1)



(H2) JCBC Screw  
M6x40mm (4)



(H3) JCBC Screw  
M6x60mm (2)



(H4) JCBC Screw  
M6x80mm (2)



(H5) Spring Washer (4)

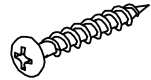

(H6) CSK Screw  
M4x32mm (16)

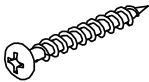

(H7) CSK Screw  
M4x38mm (4)

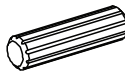

(H8) Wood Dowel (8)



(H9) Adjustment Screw  
(4)

# Step 1

1. Lay Table Leg (P2) with its bottom base facing up.
2. Insert Wood Dowels (H8) into the designated holes at the end of Leg Support (P4). Next, attach the Leg Supports (P4) onto the Table Leg (P2) as shown and align the screw holes on each part.
3. Insert a JCBC Screw (H2) through the screw hole at the bottom-end of the Leg Support (P4) into the screw hole at the middle of the Vertical Leg. Use the Allen Key (H1) to drive (H2) into (P2).

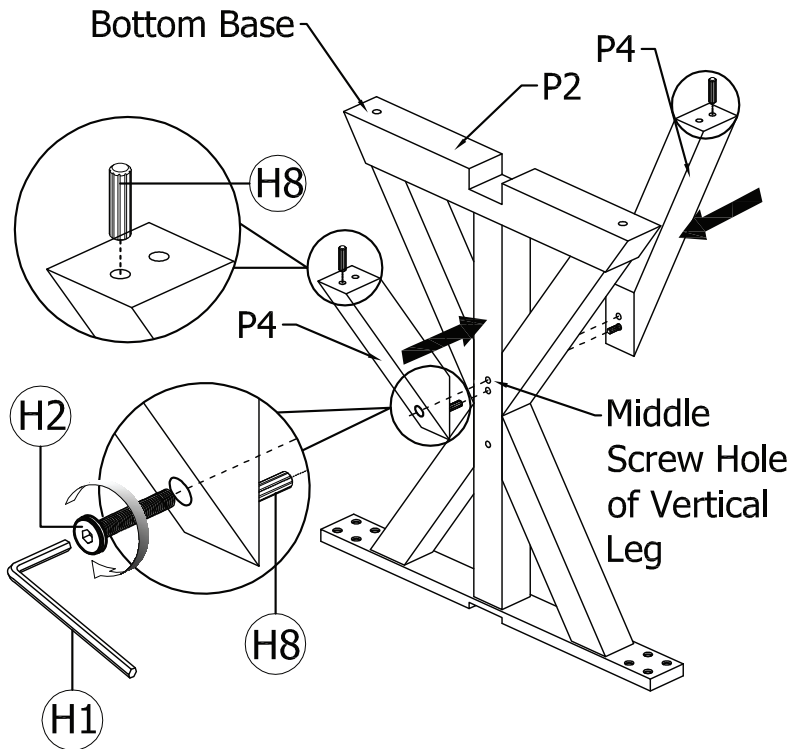

## Step 2

1. Attach the Leg Bottom (P5) onto the assembly from STEP 1 as shown. Make sure the Leg Bottom (P5) is attached to the Leg Support (P4) via the Wood Dowels on (P4) and align the screw holes on each part.
2. Insert the JCBC Screws (H4) fitted with a Spring Washers (H5) into center screw holes of the Leg Bottom (P5) as shown. Use the Allen Key (H1) to drive the screws (H4). Do not tighten completely until both screws are in place.
3. Insert CSK Screws (H7) into the screw holes located at both end of the Leg Bottom (P5) Use a Phillips Screwdriver to drive (H7) into (P5).

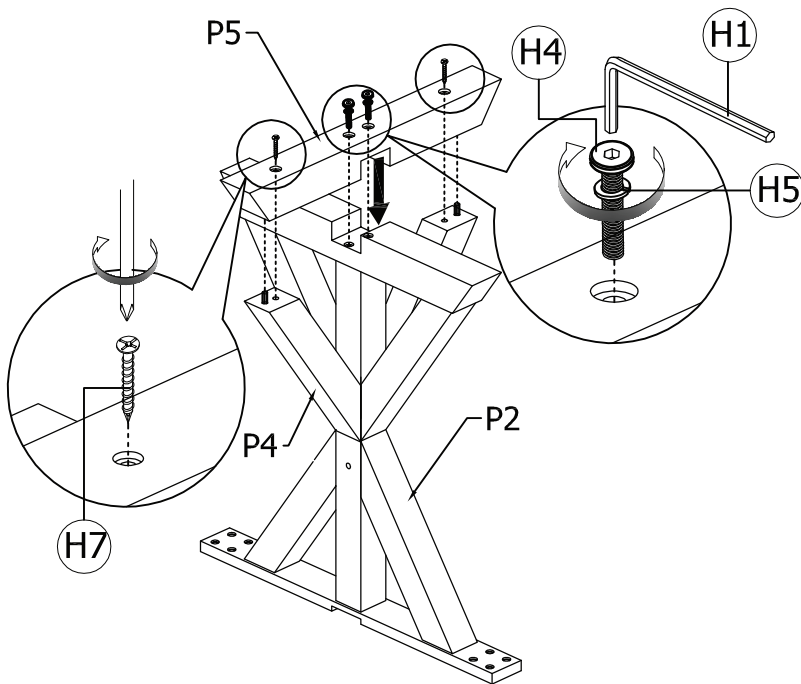



# Step 4

1. Attach the Table Support (P3) onto the assembly from STEP 3 as shown. Make sure the Table Support (P3) is attached to the Leg Support (P4) via the Wood Dowels on (P4) and align the screw holes on each part.

2. Insert JCBC Screws (H3) fitted with Spring Washers (H5) into the center screw holes of the Leg Bottom (P3) as shown. Use the Allen Key (H1) to tighten the screws. Do not tighten completely until both screws are in place.

2. Insert CSK Screws (H7) into the screw holes located at both end of Leg Bottom (P3). Use a Phillips Screwdriver to tighten the CSK Screws (H7) into the Leg Support (P4).

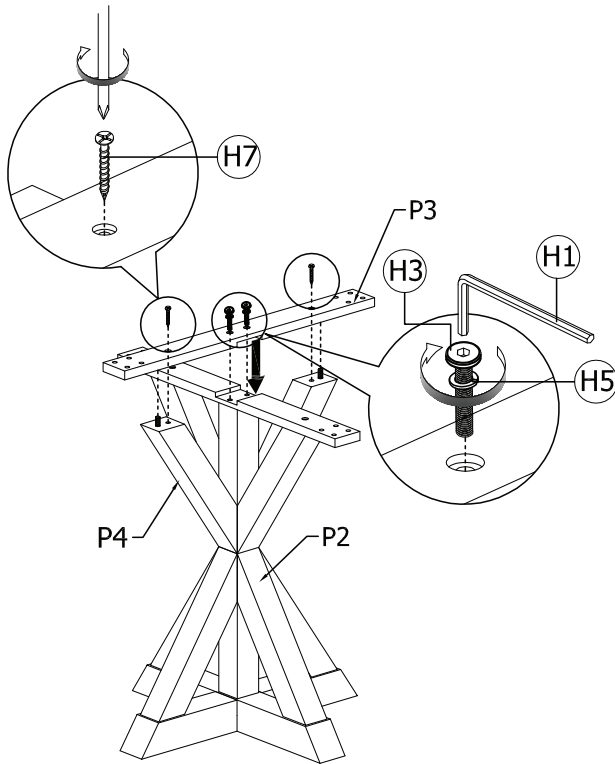

# Step 5

1. With the assistance of another person, you lay the Table Top (P1) bottom-side up on a material that does not scratch or damage the part.

2. Position the assembly from STEP 4 upside down. Align each arm of the Table Support (P2) accordingly to the markings on the Table Top (P1). Insert CSK Screws (H6) into each screw holes on the Table Support (P3). Use a Philips Screwdriver to tighten the screws (H6) to secure the Table Top (P1) to the Table Support (P3).

**Do not over-tighten the screws.**

3. Use your fingers to screw in the Adjustment Screws (H9) into the screw holes on the Leg Bottom as shown.

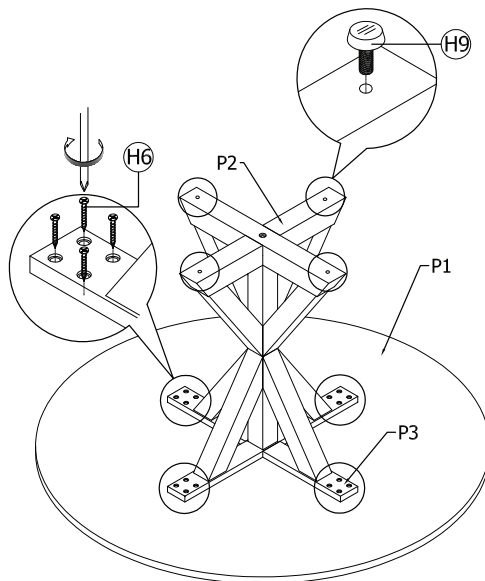

**\*The assembly of the Table is complete. Place the table right-side up. Level the table with Adjustment Screw (H8) as needed.**

# Product Dimension

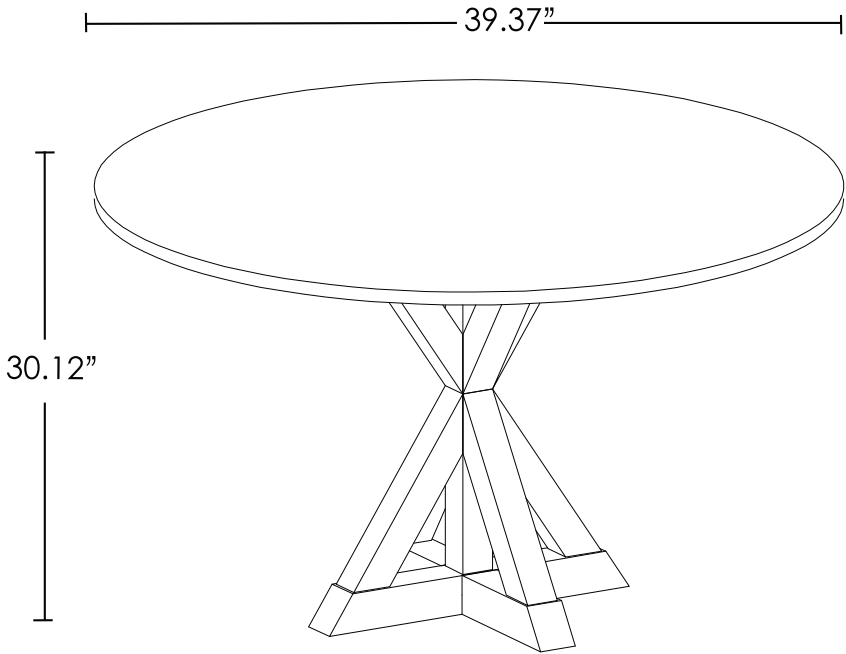

# Limited Warranty

The manufacturer's products are warranted against defects in material and workmanship while owned by the "Original Purchaser". The term "Original Purchaser" is defined as the party or entity which purchases this manufacturer's furniture from an authorized retailer as shown by the original sales receipt. This warranty does not apply to "as is" or previously owned products.

The manufacturer warrants its products to be free from defects in materials and workmanship (normal wear and tear, fading and stretching excepted), for one year from the date of purchase, except as provided below under the limited warranty. The exceptions or exclusions to this warranty are as follows:

1. Any warranty claim that is submitted after the limited warranty period, or without proper proof of purchase will not include the cost of parts, labor, or delivery.
2. This warranty shall not apply to the manufacturer's products which have been subjected to misuse, neglect, alteration, modification, or attachments, either caused by the Original Purchaser, shipping, storage, accident, fire, flood, or acts of God.

In the event of a defect in material or workmanship covered by this warranty, the manufacturer will repair or replace, at their discretion, without charge the warranted parts within a reasonable amount of time. We reserve the right to require damaged parts be returned to us upon request. Natural markings such as scars, brands, grain variations, wrinkles, color variations, etc. will be considered normal characteristics and not construed as defects.

For claims or questions concerning this warranty, please contact customer service department on the web. Be prepared to provide your name, address, daytime phone number, the model and purchase order number of the product, date of purchase, and the website where it was purchased. The manufacturer requires that the original sales receipt be submitted with all requests to confirm that you are the Original Purchaser according to our written warranty.

This warranty gives you specific rights, and you may also have other rights, which vary from state to state (or country to country). All warranties are limited to the Original Purchaser for normal use. Should you prefer to speak with a service representative, you may call toll free.