

# MODEL : B131

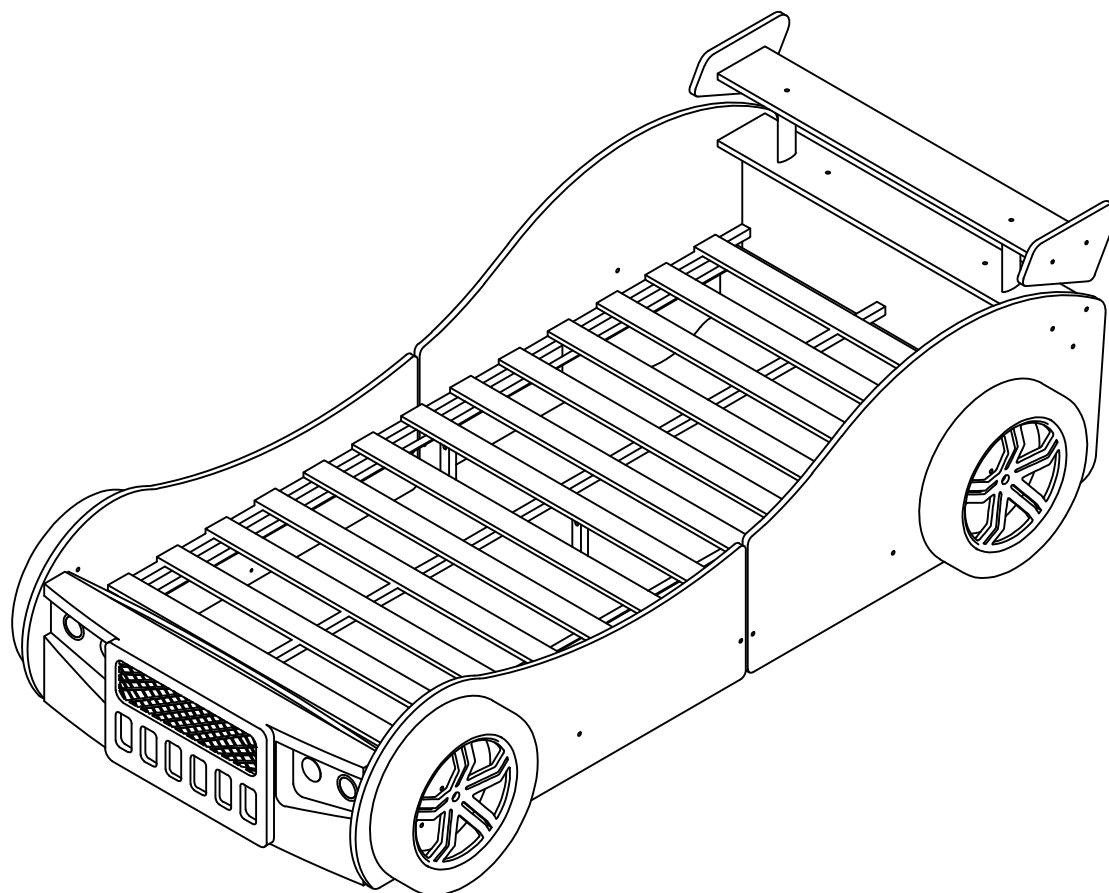

ASSEMBLE DIFFICULTY

1 2 ③ 4 5

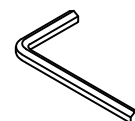
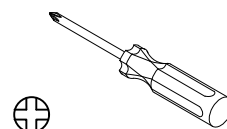
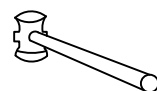
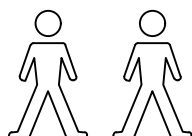









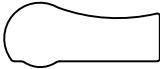







- User Age: 72 Months Or Above.
- Standard Of Paint: EN1725:1998  
EN1022:2005  
EN71-1:2014  
EN71-3:2013+A1:2014





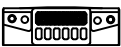

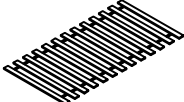

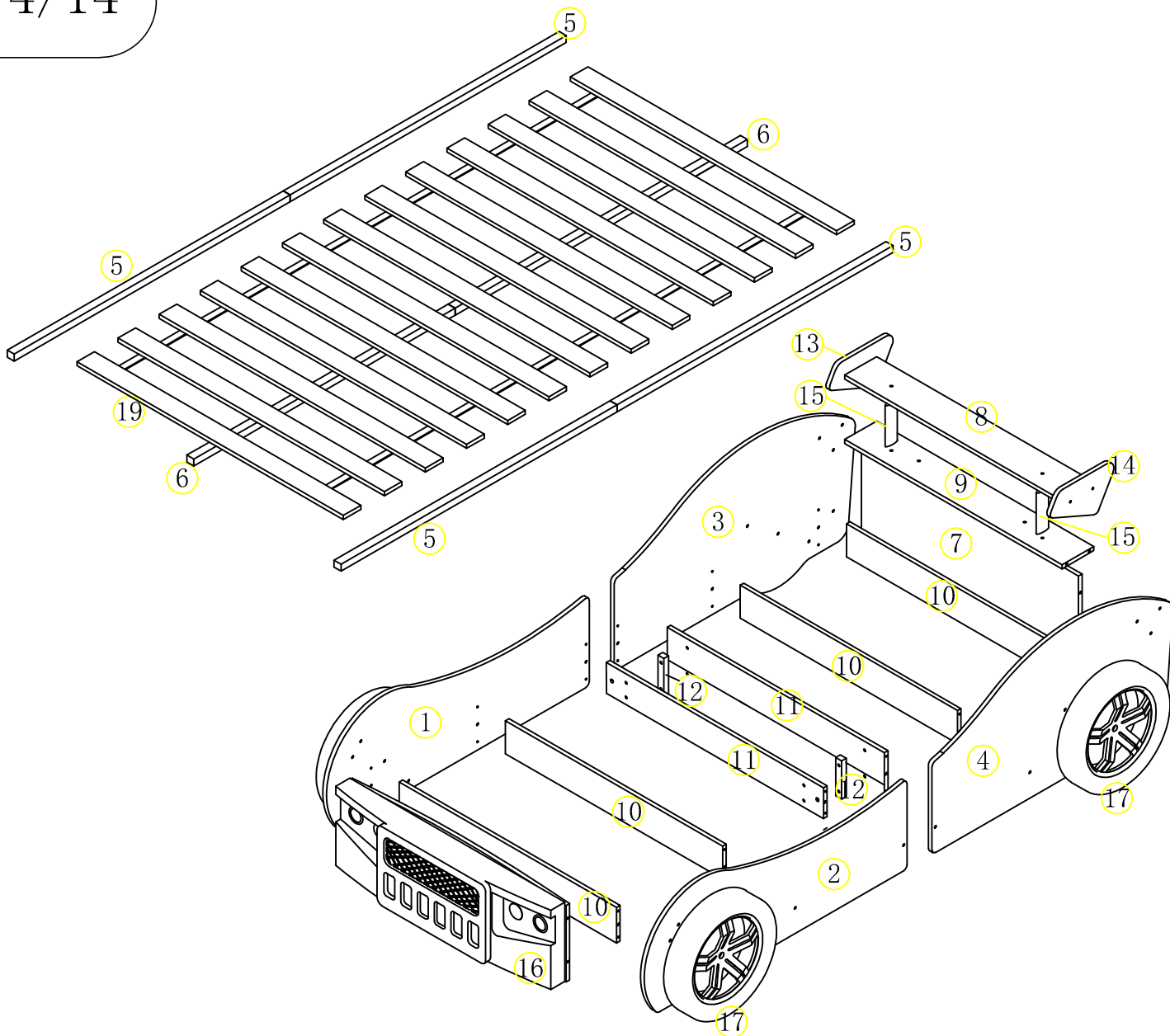



IMPORTANT, RETAIN FOR FUTURE REFERENCE: READ CAREFULLY

- Information regarding maintenance  
Use dry, clean & soft cloth rub on the surface regularly; must not use any wet cloth, hardware or any hard material (such as keys, knife, sand-paper) rub on the surface. Keep away from water and any chemical substances.
- Conditions for use of the product domestic
- Installation only to be carried out by a competent person
- Article consists swallowable small parts, children  $\leq 3$  years should not be without parental guidance (surveillance or monitoring)
- Screw lock must be inserted before joining
- For the safety reason all of the hardware must be screwed tidely.
- This Product must be assembled by adult
- To avoid surface damage, tight all serew must not use over 5Nm power.

## DESCRIPTION OF COMPONENT

ITEM NO	WORK PIECE DESCRIPTION	MEASUREMENT	QTY	SHAPE	PACK IN BOX
(1)	FRONT SIDE BOARD(L)	1066*439*15	1		1/2
(2)	FRONT SIDE BOARD(R)	1066*439*15	1		1/2
(3)	FRONT SIDE BOARD(L)	1066*593*15	1		1/2
(4)	REAR SIDE BOARD(R)	1066*593*15	1		1/2
(5)	BATTEN-1	953*25*22	4		1/2
(6)	BATTEN-2	953*25*22	2		1/2
(7)	BACK PANEL	1000*354*15	1		1/2
(8)	REAR UPPER MIDDLE FILTER	1000*135*15	1		1/2
(9)	REAR LOWER MIDDLE FILTER	1000*135*15	1		1/2
(10)	BEAM	1000*100*15	4		1/2
(11)	MIDDLE HORIZONTAL PLATE	1000*100*15	2		1/2
(12)	ARTICLE RIBS	216*25*20	2		2/2
(13)	REAR UPPER SIDE BOARD(L)	272*162*15	1		2/2
(14)	REAR UPPER SIDE BOARD(R)	272*162*15	1		2/2
(15)	CONNECTED IRON	150*50*20	2		2/2
(16)	FRONT PANEL (ITEM 12-14 INCLUDED IN THIS PART)	1000*300*15	1		2/2
(17)	TYRE (ITEM 16-17 INCLUDED IN THIS PART)	380*380*62	4		2/2
(18)	HARDWARE	216*114*57	1		2/2
(19)	PLYWOOD SLAT	1900*995*12	1		2/2



A	B	C	D	E	F
					
M6*55 QTY:4	QTY:4	M6*50 QTY:30	d6*30 QTY:24	QTY:4	4#*30 QTY:12
G	H	I	J	K	L
					
QTY:30	M6*40 QTY:4	M6*70 QTY:4	4#*20 QTY:12	QTY:4	QTY:1

# SCALE 1:1

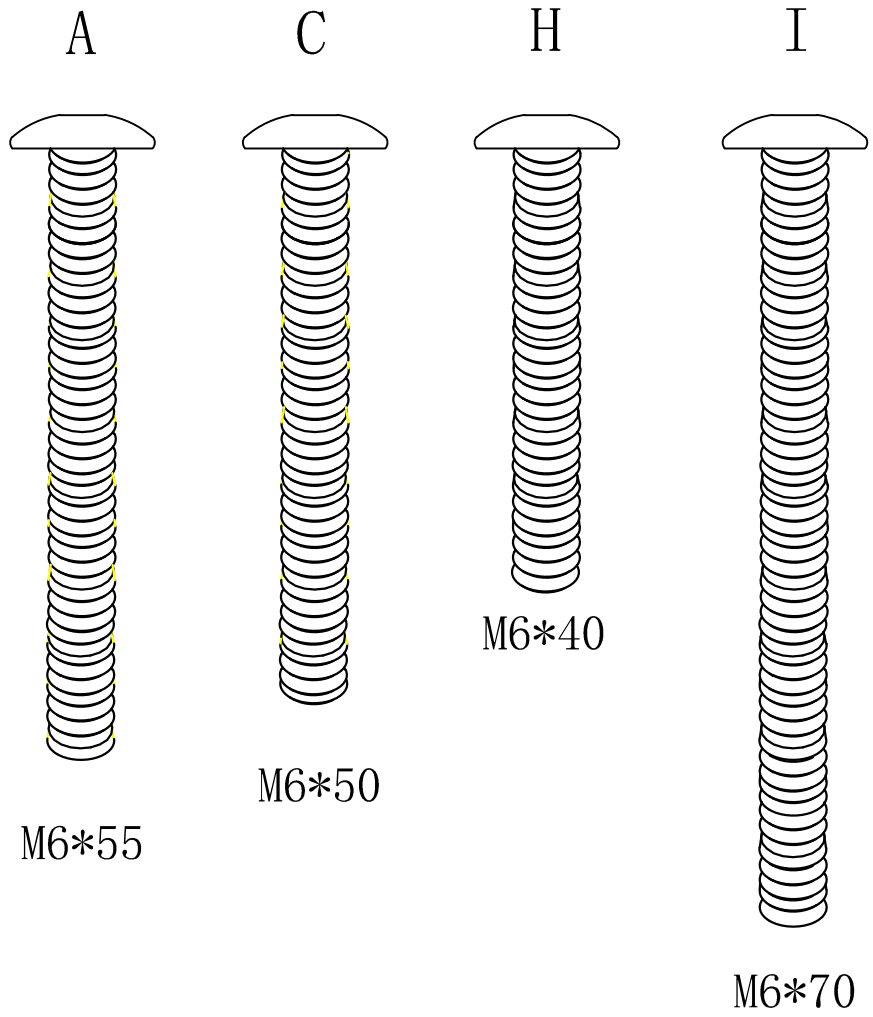

1

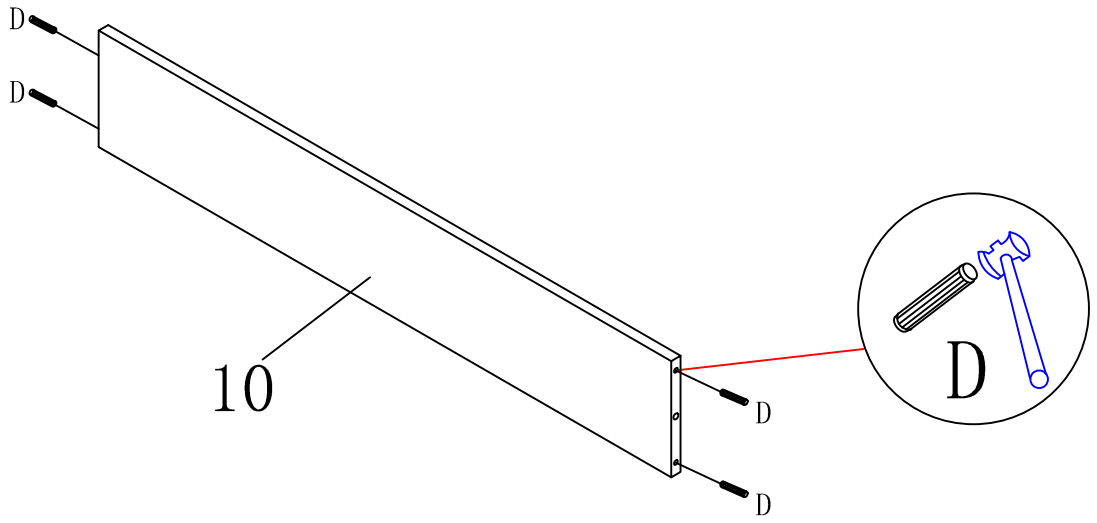

4X

D



d6\*30  
QTY: 16

2

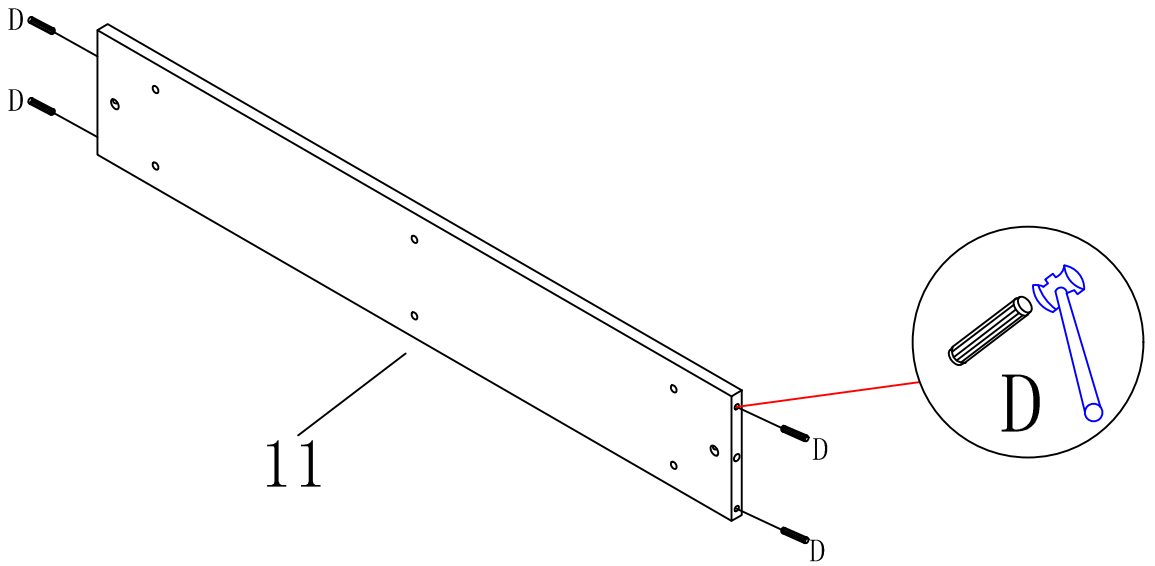

2X



D

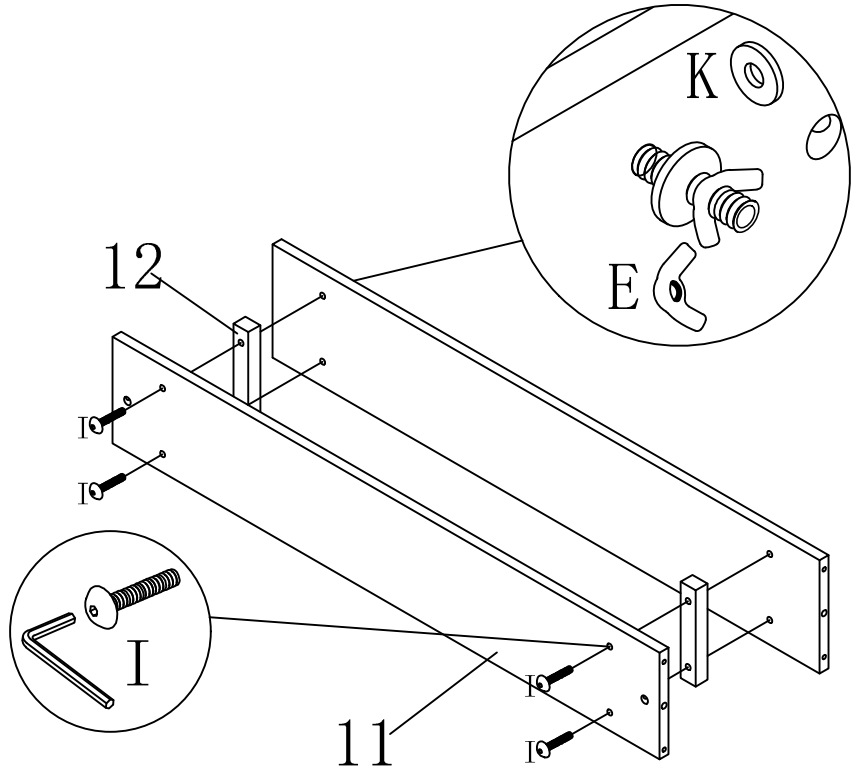

d6\*30  
QTY: 8

3



I		M6*70 QTY:4	E		QTY:4	K		QTY:4
---	---	----------------	---	---	-------	---	---	-------

4

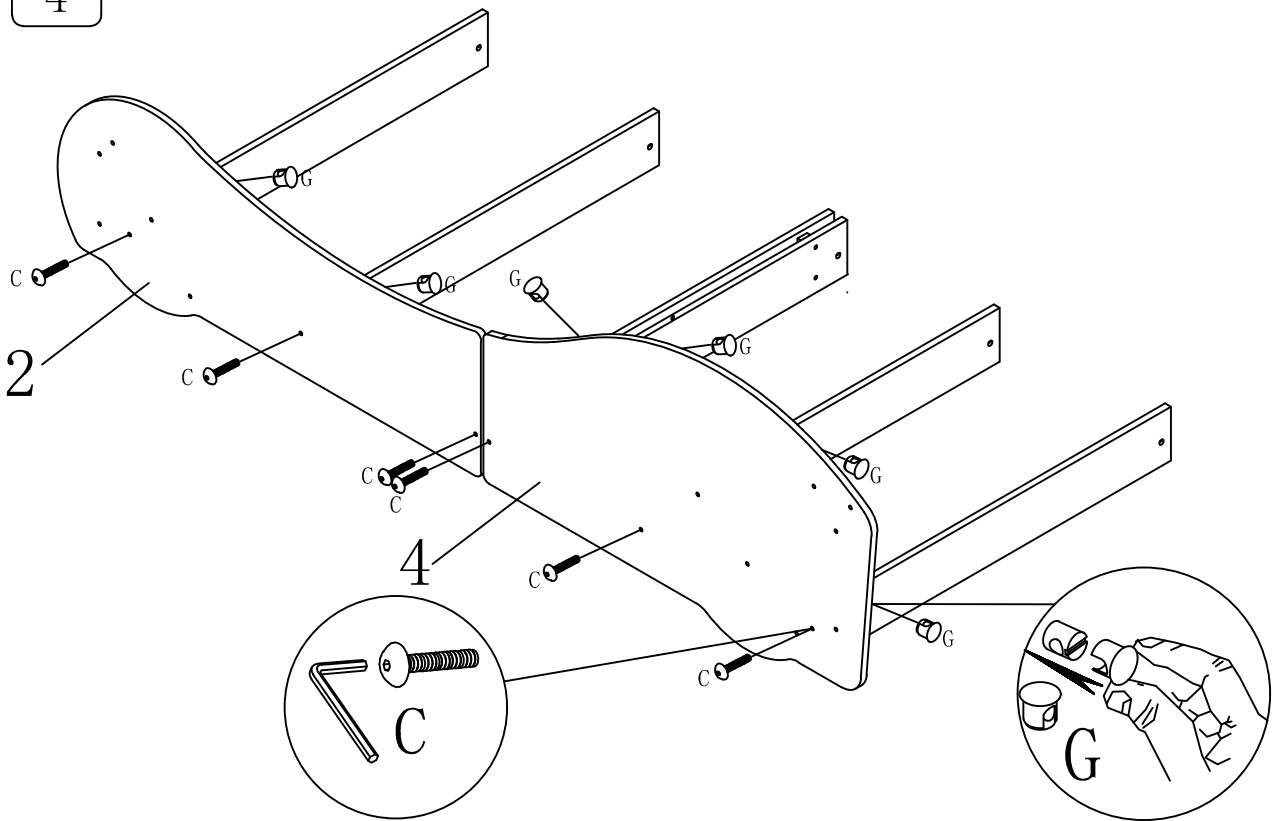

C		M6*50 QTY:6	G		QTY:6
---	---	----------------	---	---	-------

5

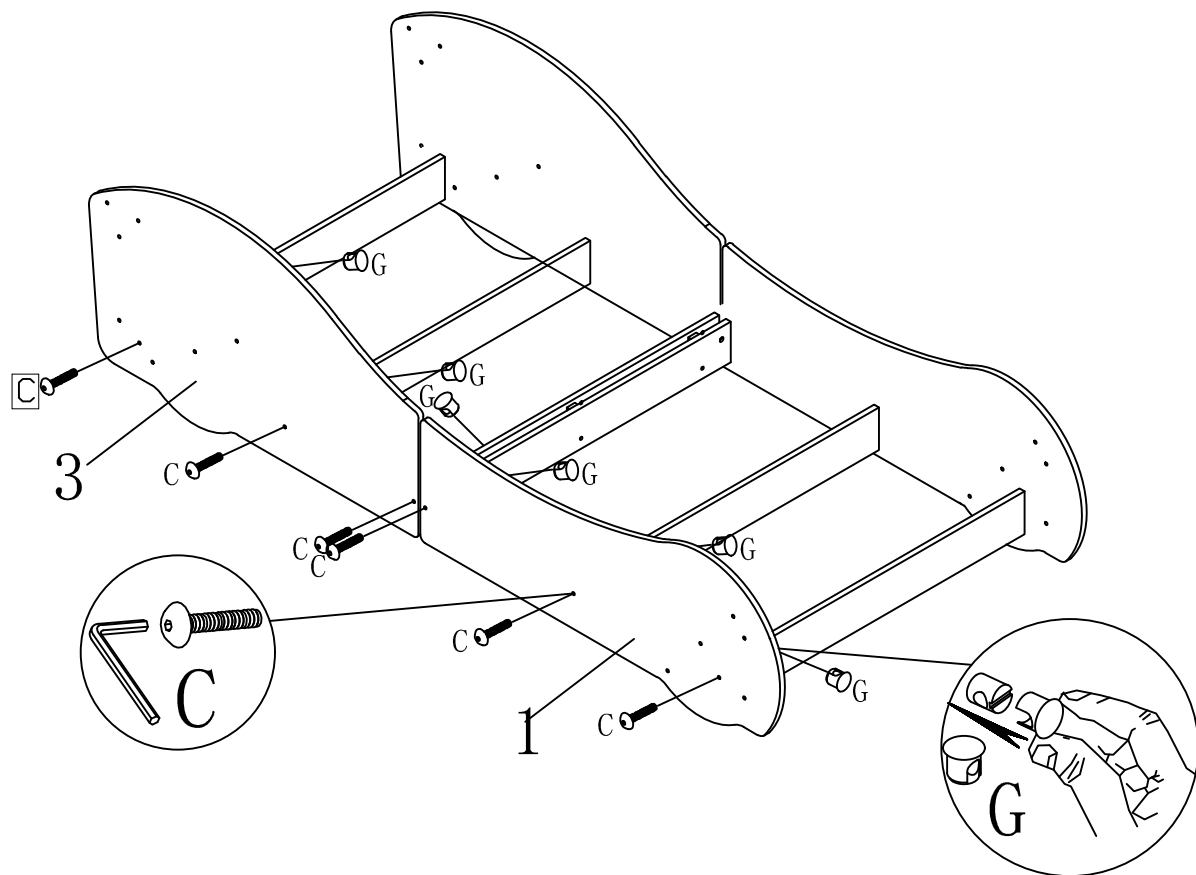

C



M6\*50  
QTY:6

G



QTY:6

6

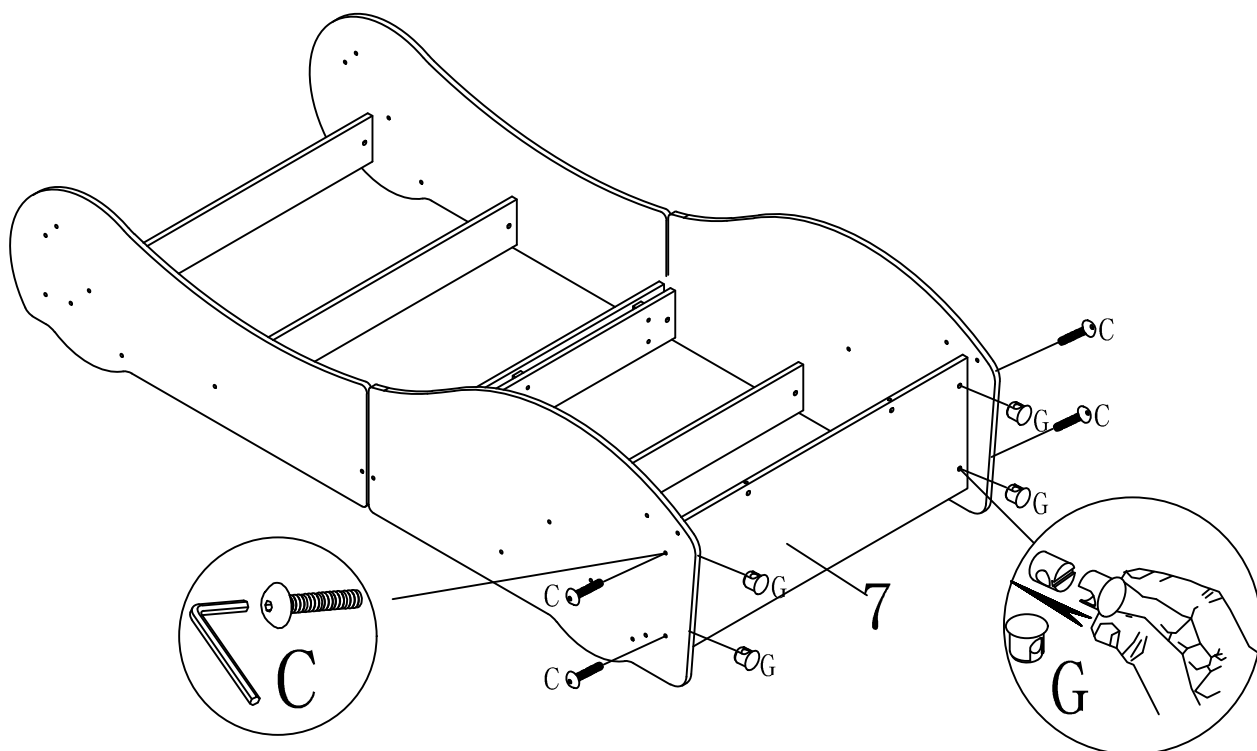

C



M6\*50  
QTY:4

G



QTY:4

7

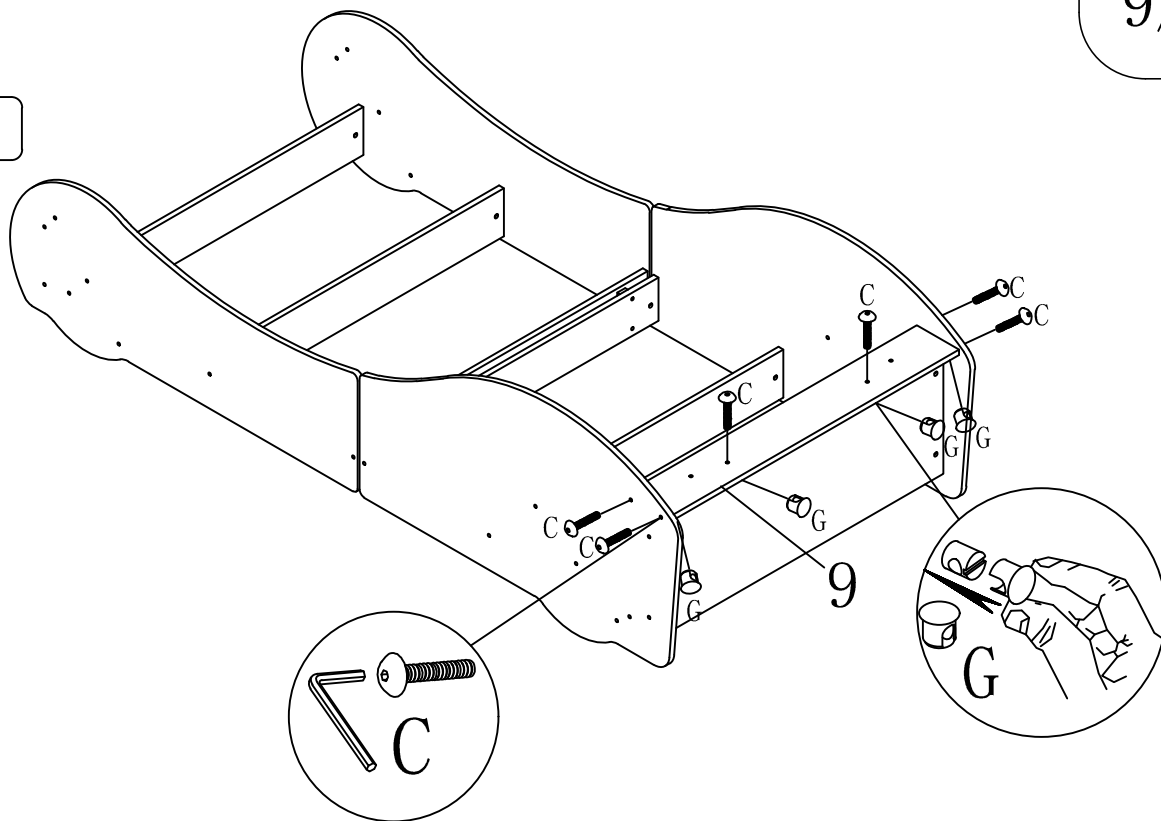

C  M6\*50  
QTY:6

G   QTY:6

8

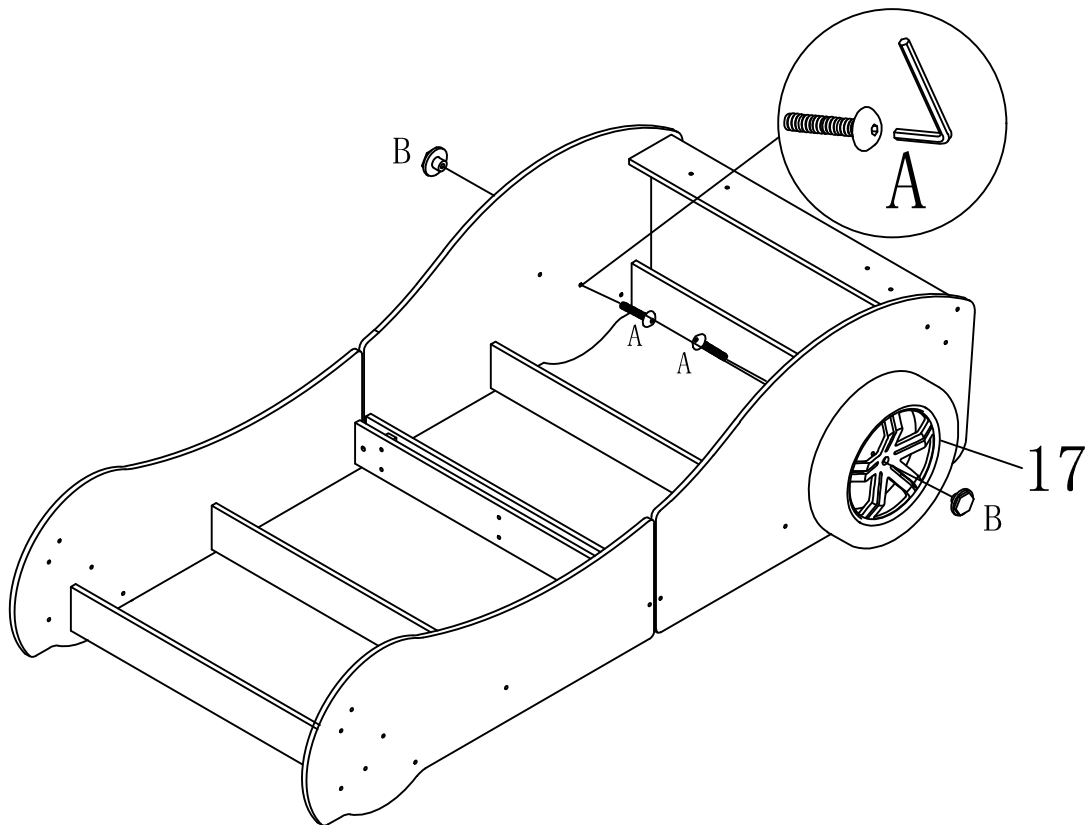

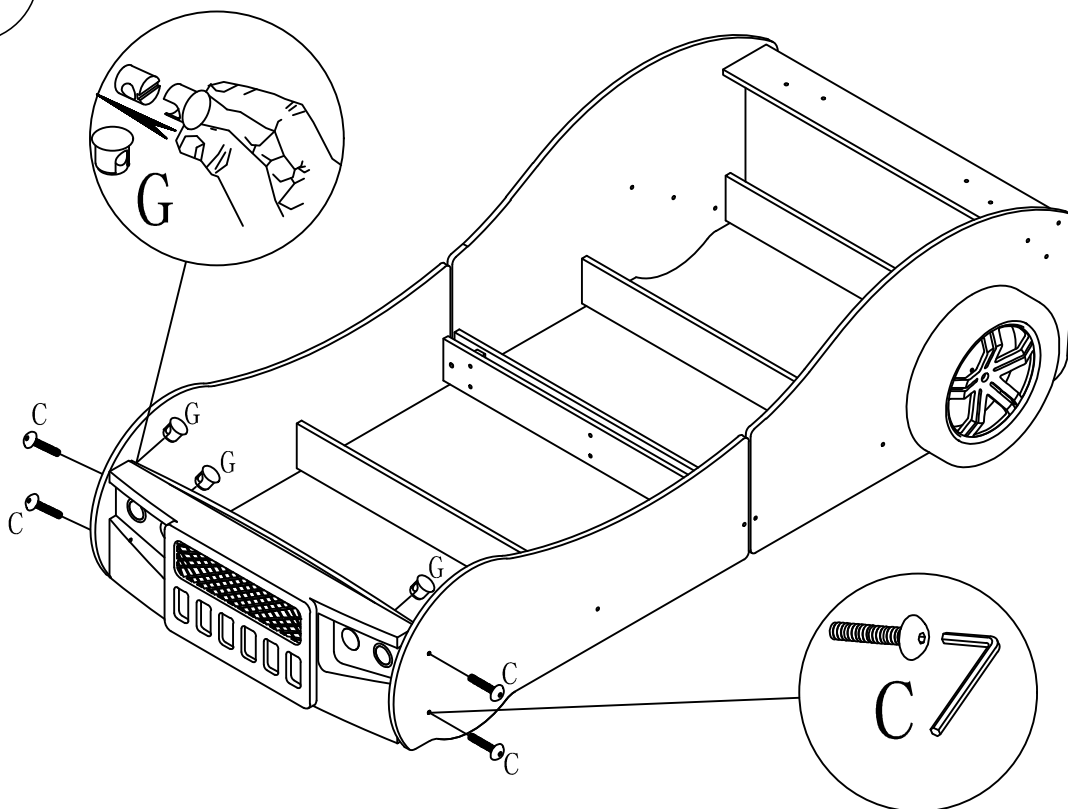

A  M6\*55  
QTY:2

B  QTY:2



C  M6\*50  
QTY: 4

G   QTY: 4

10

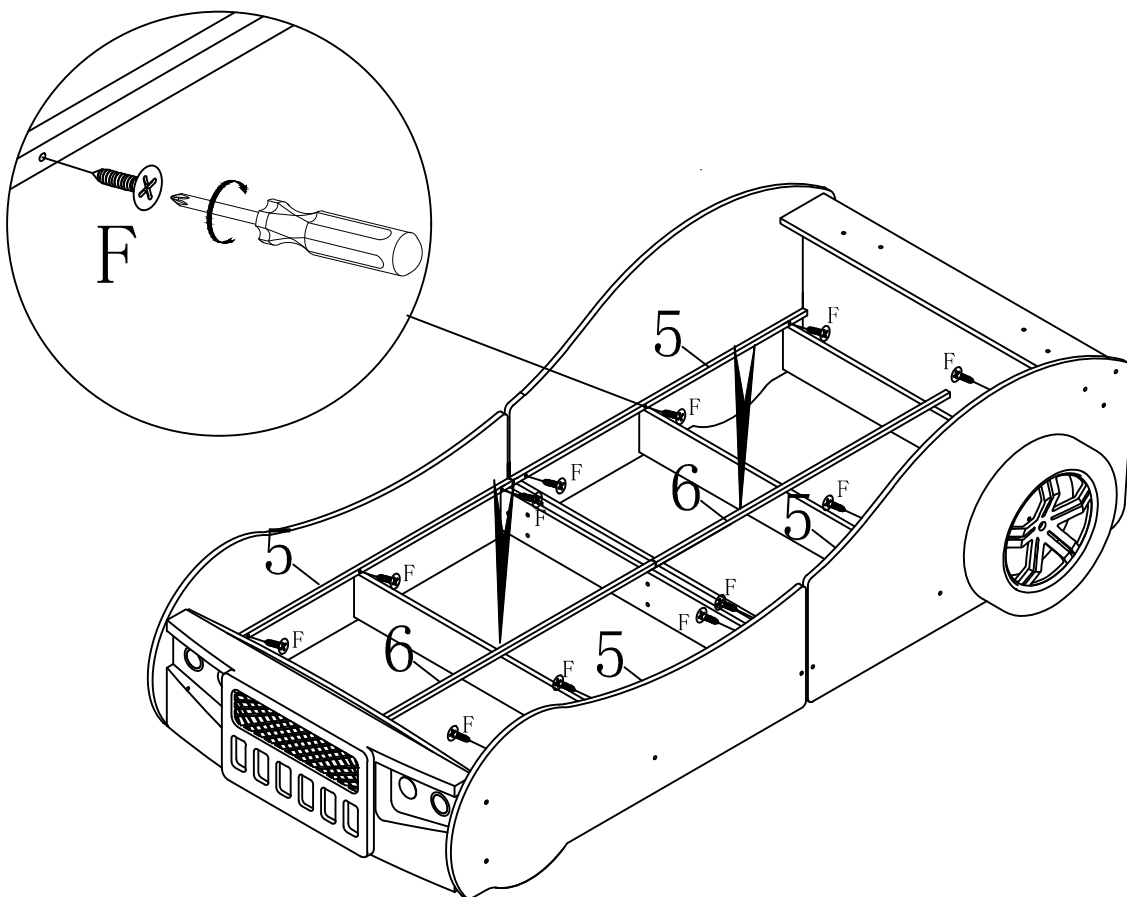

F  4#\*30  
QTY: 12

11

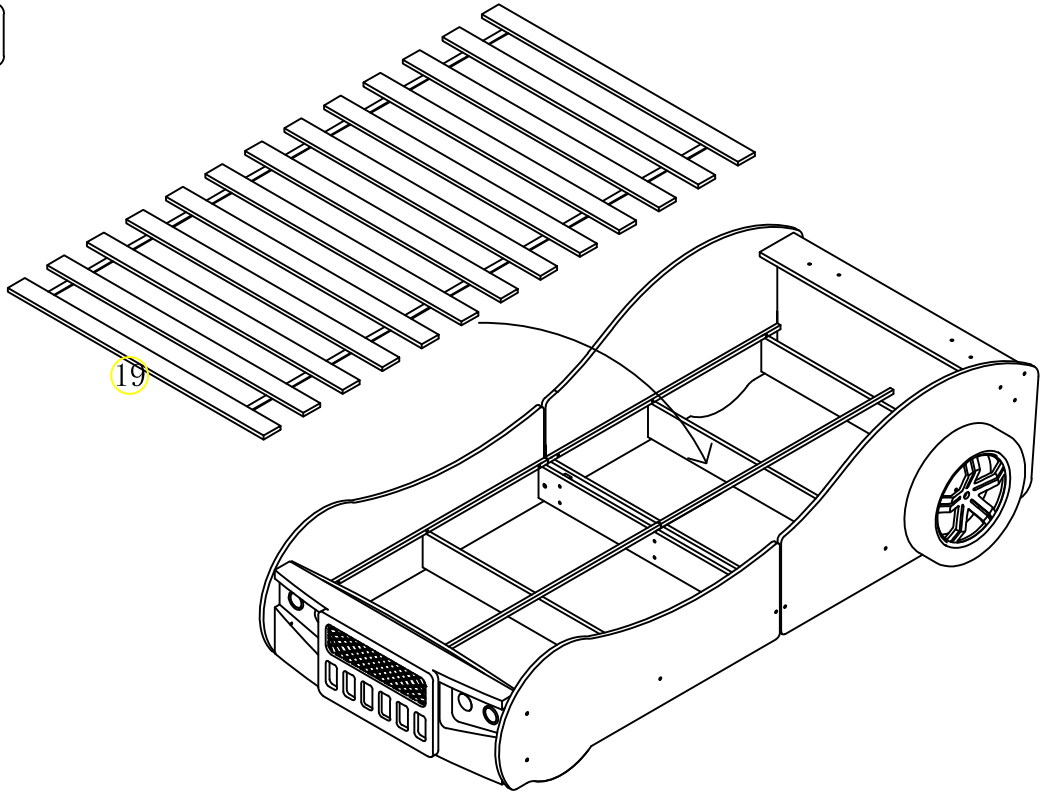

12

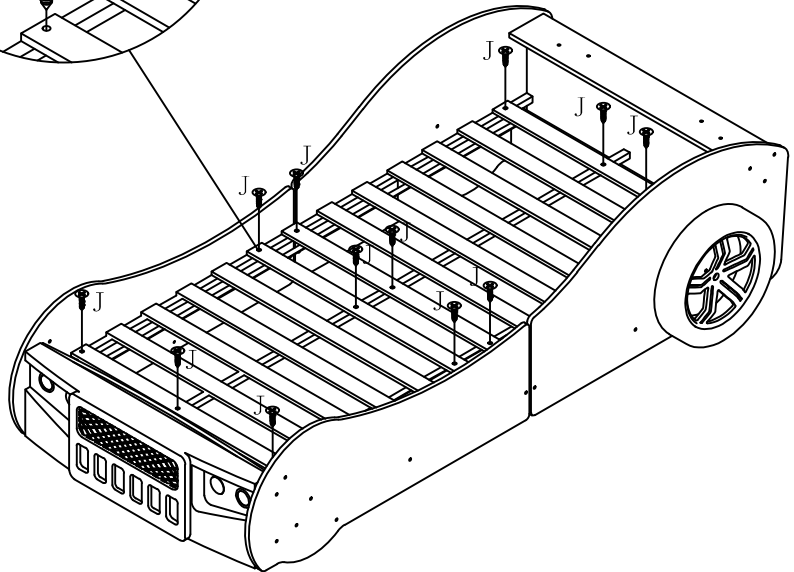
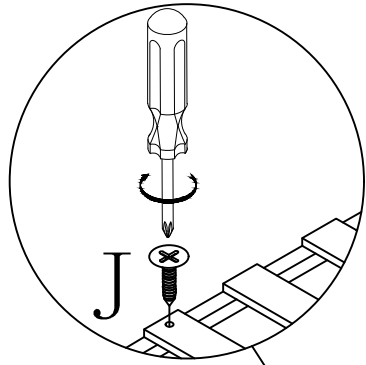

J



4#\*20  
QTY:12

13

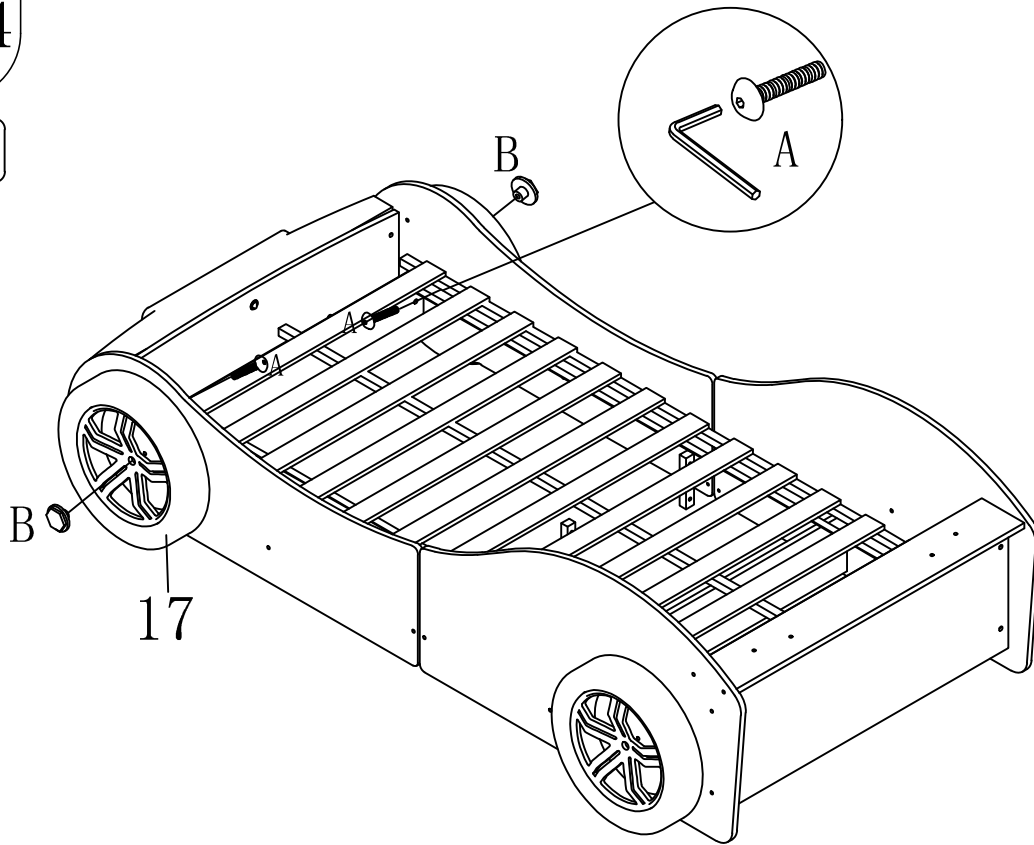

A



M6\*55  
QTY:2

B



QTY:2

14

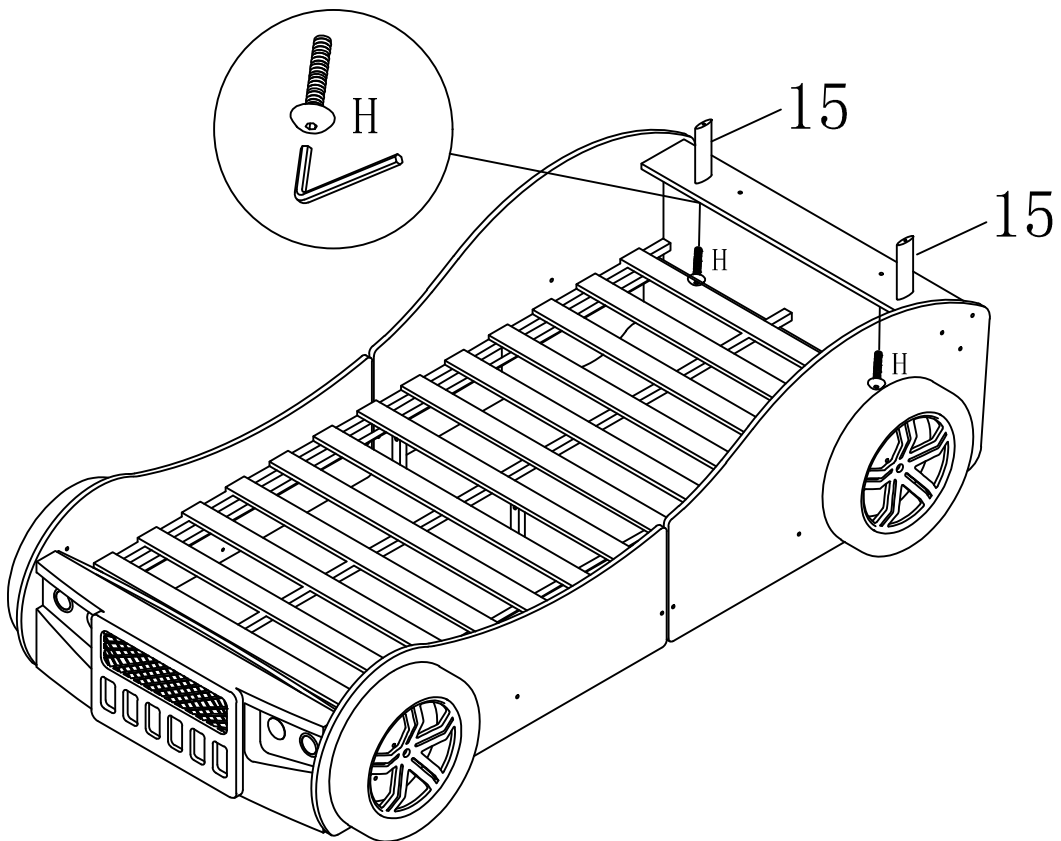

H



M6\*40  
QTY:2

15

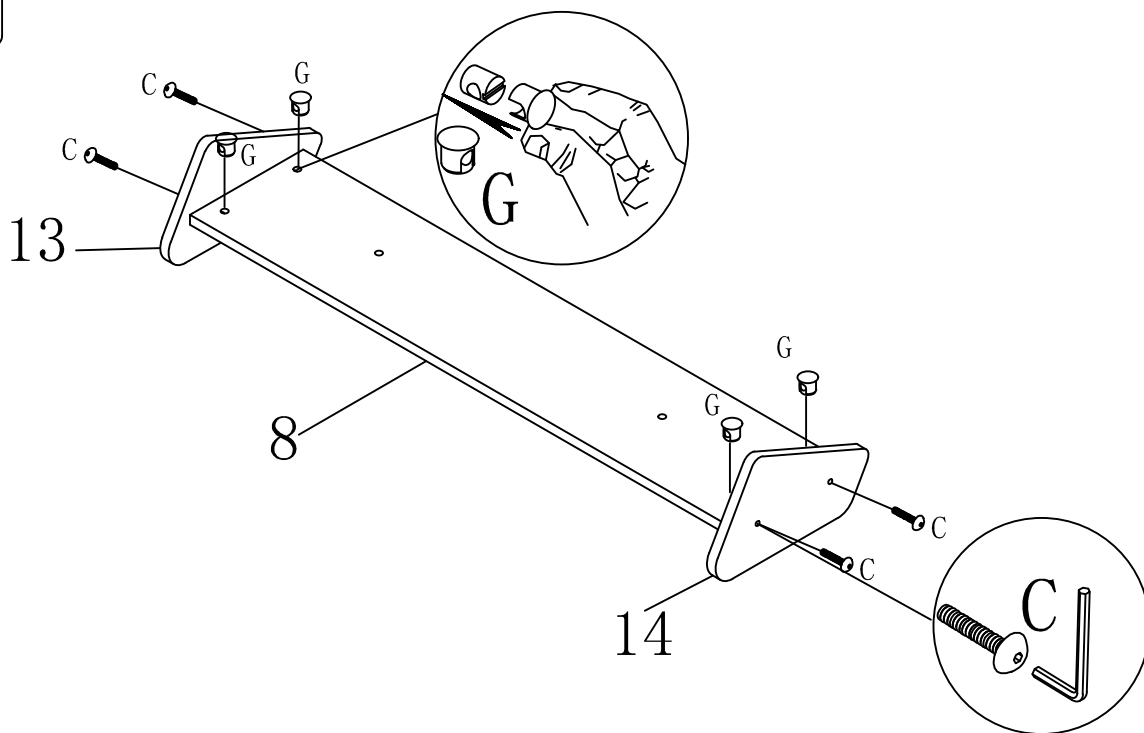

C



M6\*50  
QTY:4

G



QTY:4

16

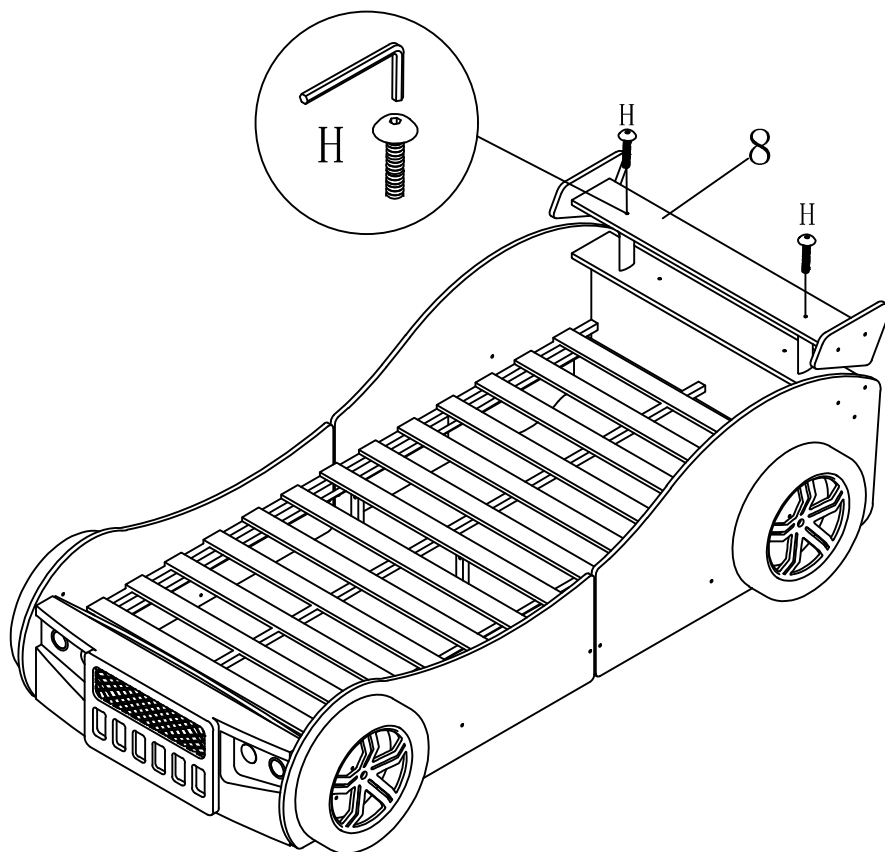

H



M6\*40  
QTY:2

17

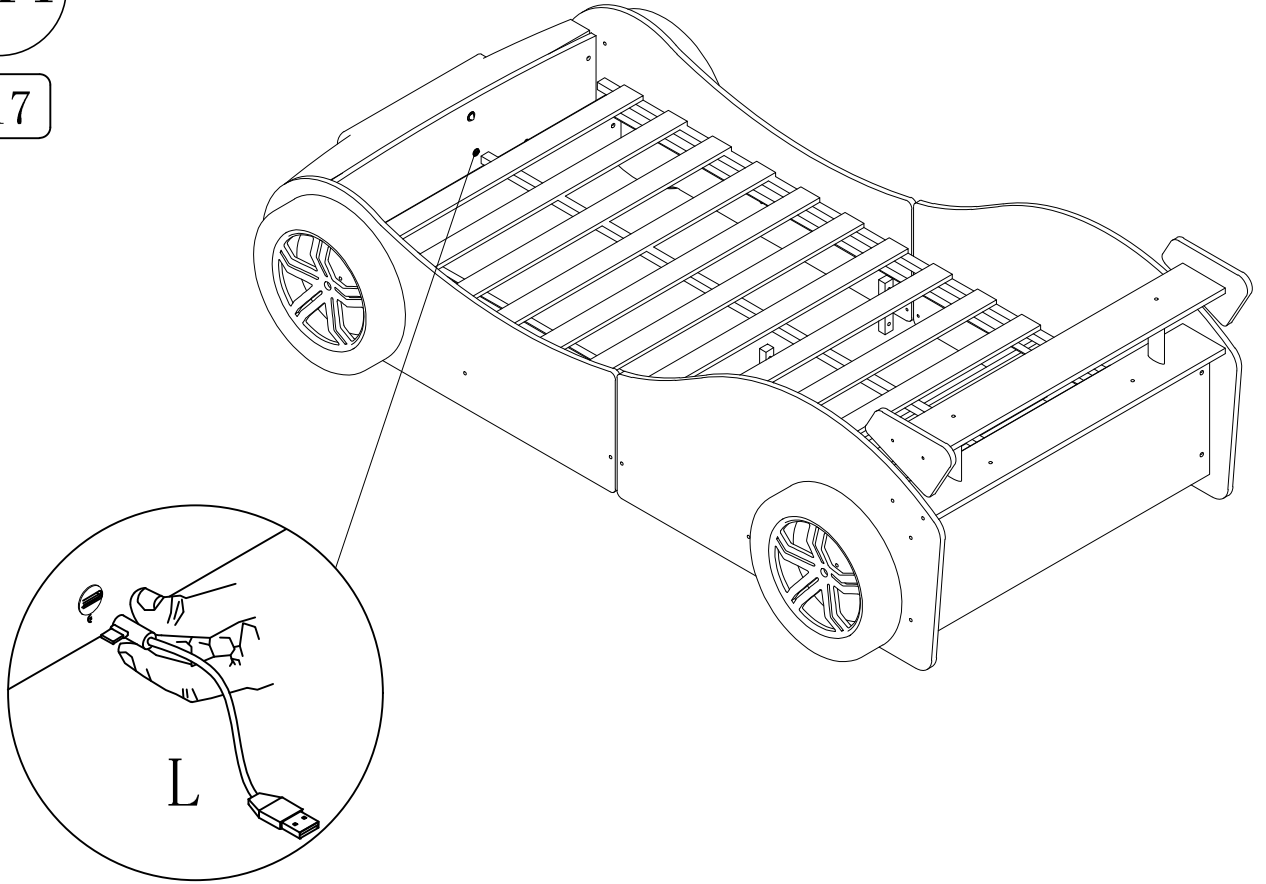

L



QTY: 1

18

