

ASSEMBLY INSTRUCTION

ASSEMBLY INSTRUCTIONS

ASSEMBLY TIPS:

1. Remove hardware from box and sort by size.
2. Please check to see that all hardware and parts are present prior to start of assembly.
3. Please follow attached instructions in the same sequence as numbered to assure fast & easy assembly.



Warning!

1. Don't attempt to repair or modify parts that are broken or defective. Please contact the store immediately.
2. This product is for home use only and not intended for commercial establishment.

PARTS IDENTIFICATION

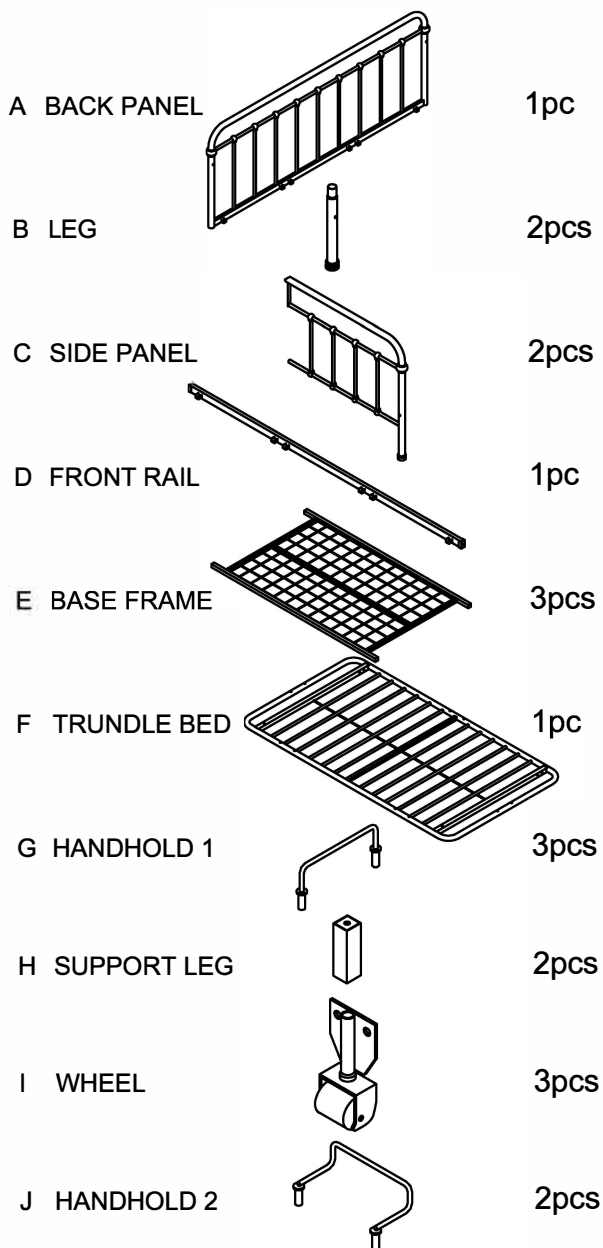

ASSEMBLY TIME PER UNIT: 30 MINUTES

Z HARDWARE LIST:

NO	DESCRIPTION	FIGURE	Q`TY
1	BOLT 5/16"X2-1/4"		2pcs
2	BOLT 1/4"X2-1/4"		4pcs
3	BOLT 1/4"X1-3/4"		4pcs
4	BOLT 1/4"X1-3/8"		2pcs
5	BOLT 1/4"X5/8"		22pcs
6	BOLT 1/4"X2"		2pcs
7	HEX . NUT		6pcs
8	WASHER φ16		18pcs
9	WASHER φ30		2pcs
10	SMALL ALLEN WRENCH 4x4MM		1pc
11	LARGER ALLEN WRENCH 5x5MM		1pc
12	OPEN END WRENCH		1pc

ASSEMBLY

Do not fully tighten all bolts until assembly is complete. This will help all parts to assemble properly.

STEP 1: Align and attach the leg (B) to the back panel (A). As shown on the drawing.

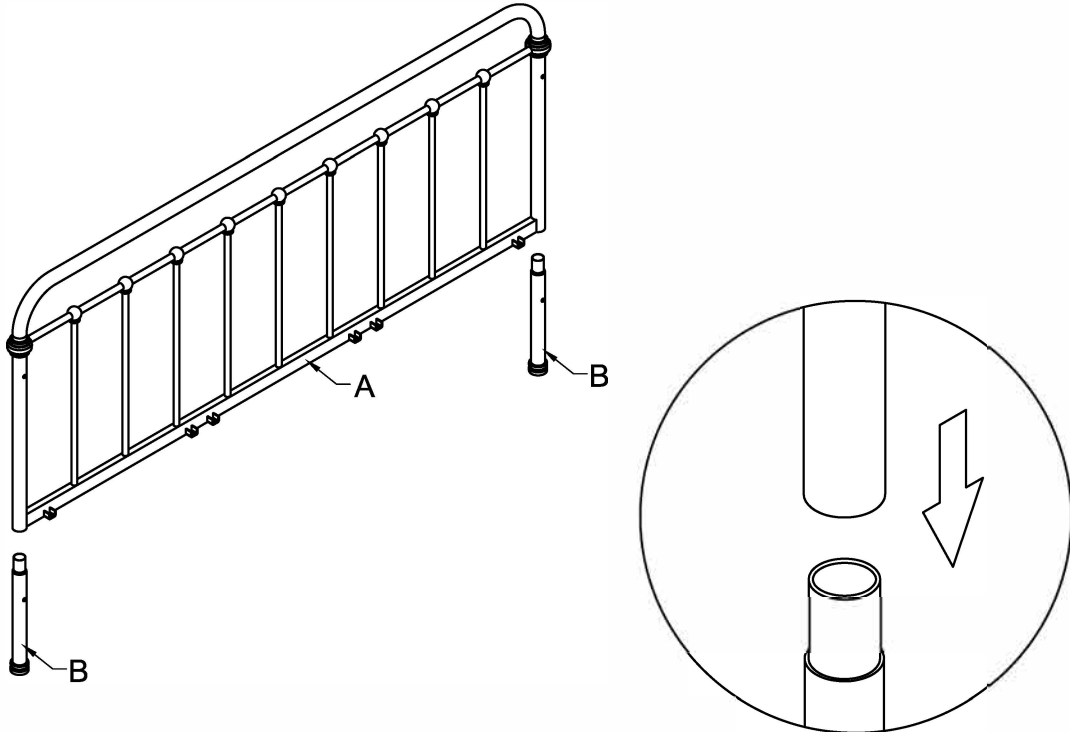

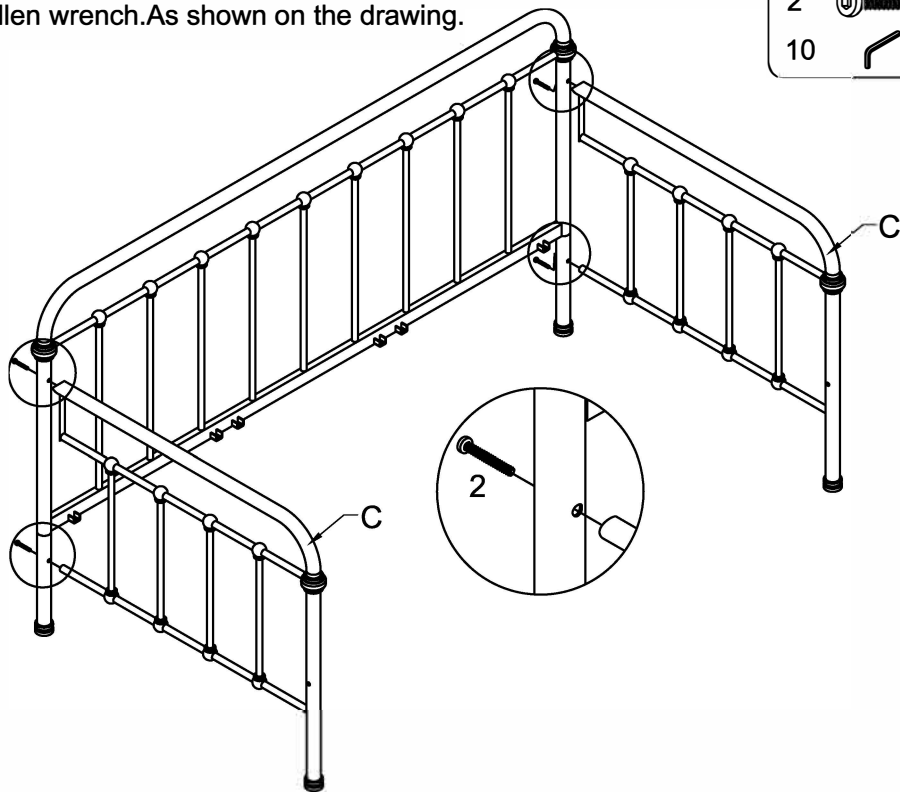

STEP 2: Assemble the side panel (C) to the back panel using bolt (2), tighten with allen wrench. As shown on the drawing.

2  4PCS
10 



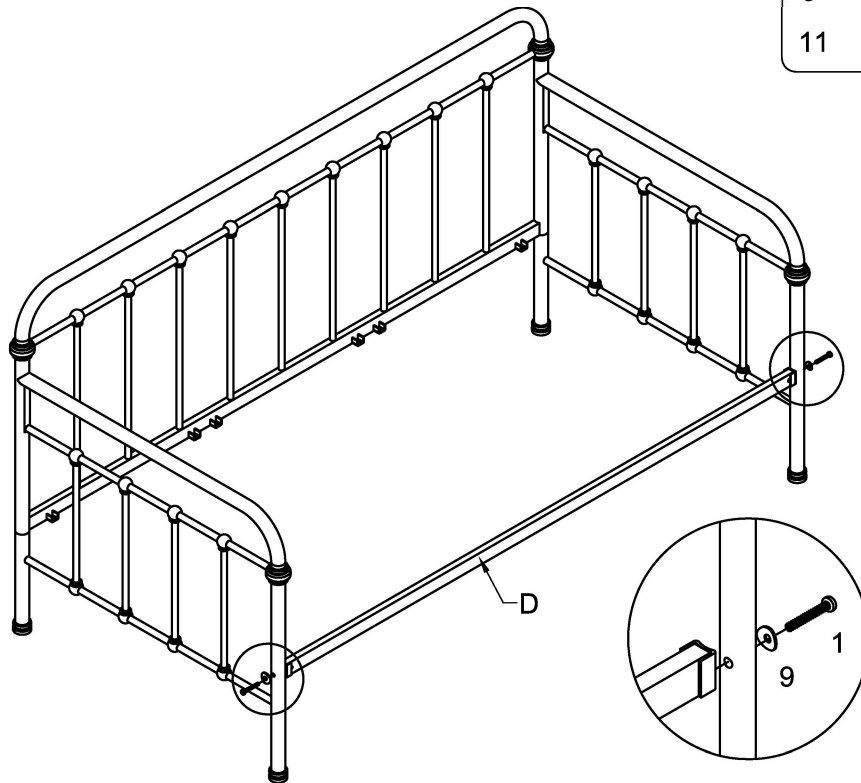

STEP 3: Assemble the front rail (D) to the side panel using bolt (1), washer (9) tighten with allen wrench. As shown on the drawing.

- | | | |
|----|---|------|
| 1 |  | 2PCS |
| 9 |  | 2PCS |
| 11 |  | |







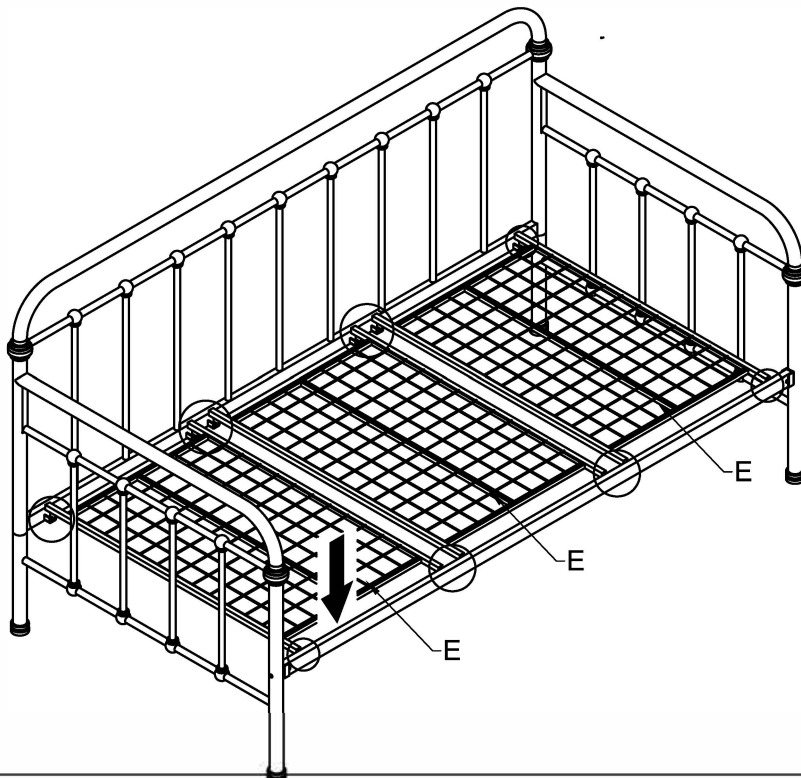

STEP 4: Put the base frame (E) onto the front rail and back panel, using the bolt (5), washer (8), tighten with allen wrench. As shown on the drawing.

- | | | |
|----|---|-------|
| 5 |  | 12PCS |
| 8 |  | 12PCS |
| 10 |  | |



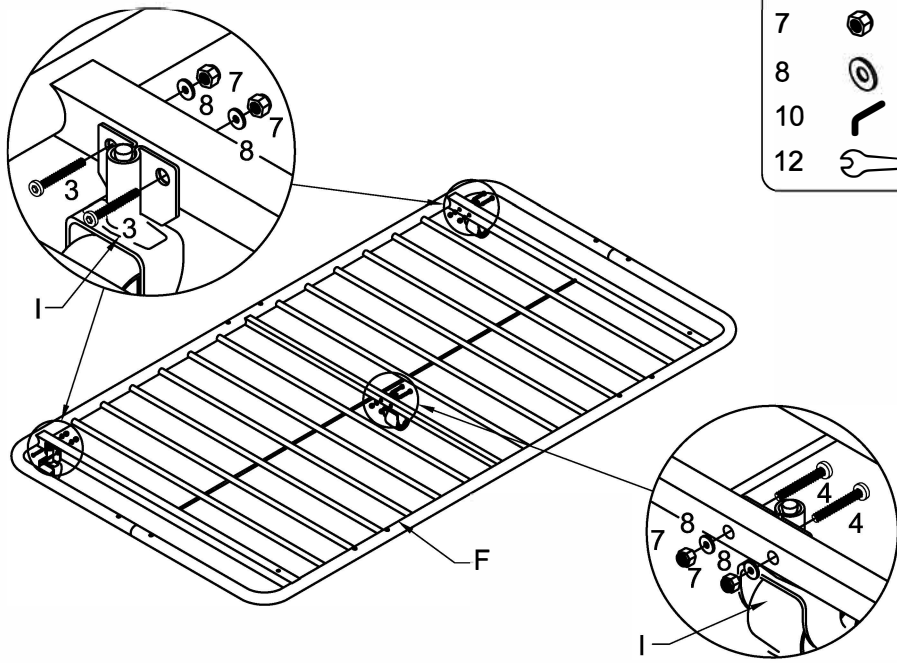

STEP 5: Align and attach the block (I) to the trundle bed (F) using the bolt (3) & (4), washer (8), and hex. nut (7), tighten with allen wrench (10) & (12). As shown on the drawing.

3		4PCS
4		2PCS
7		6PCS
8		6PCS
10		
12		



STEP 6: Align the support leg (H) and the trundle bed (F) then attach them together, using the bolt (6), finally, tighten with allen wrench. As shown on the drawing.

6		2PCS
10		

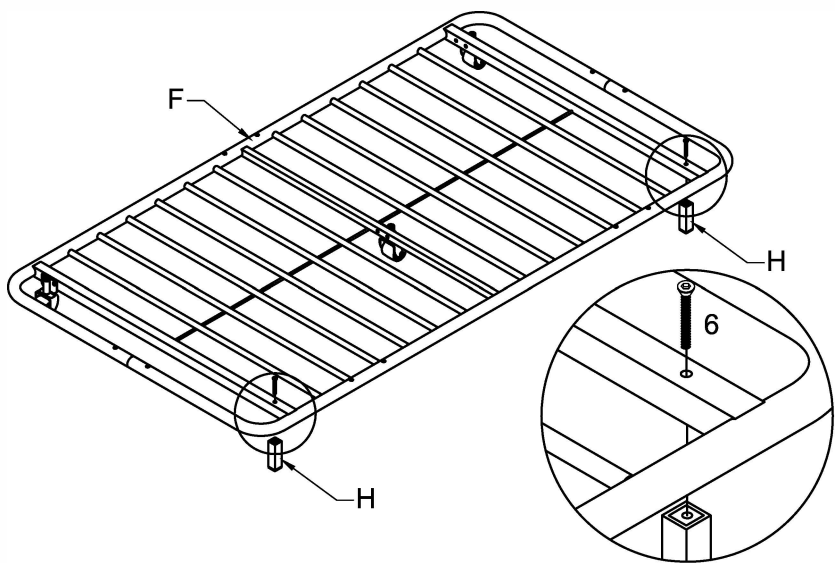

STEP 7:Align the handhold (G) and the trundle bed (F) then attach them together,using the bolt (5),finally, tighten with allen wrench. As shown on the drawing.

5  6PCS
10 

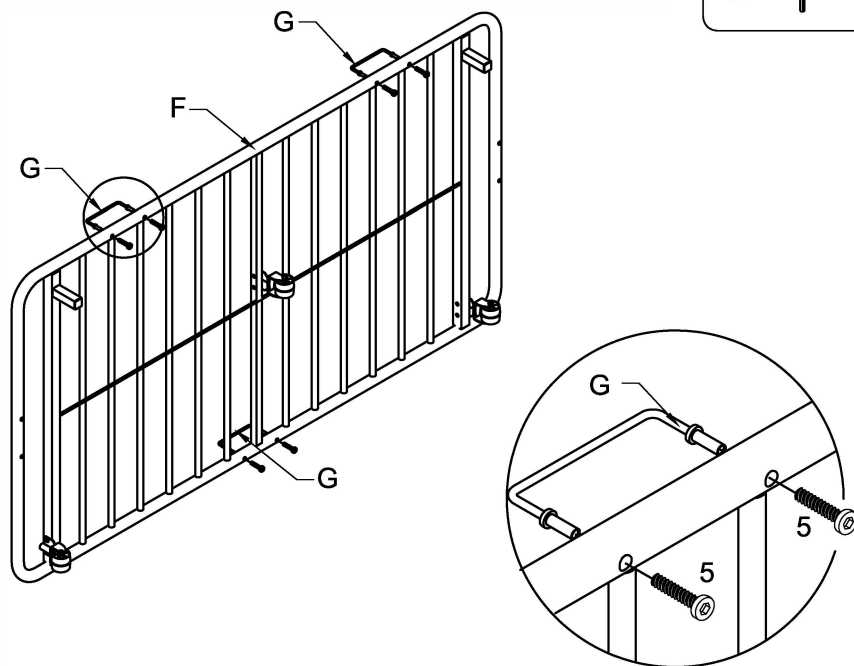

STEP 8:Align the handhold 2 (J) and the trundle bed then attach them together,using the bolt (5),finally, tighten with allen wrench. As shown on the drawing.

5  4PCS
10 

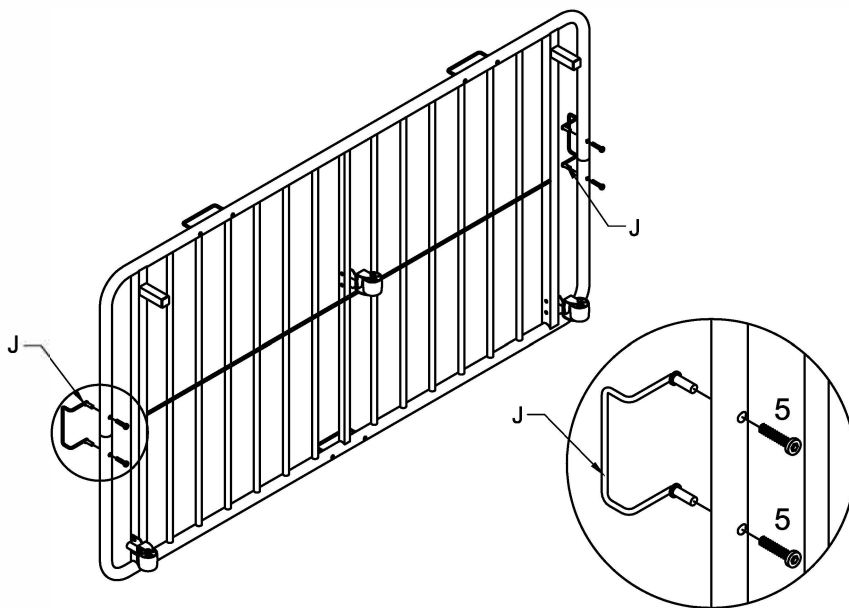

STEP 9: Put the assembled the trundle bed under the daybed, as shown on the drawing.

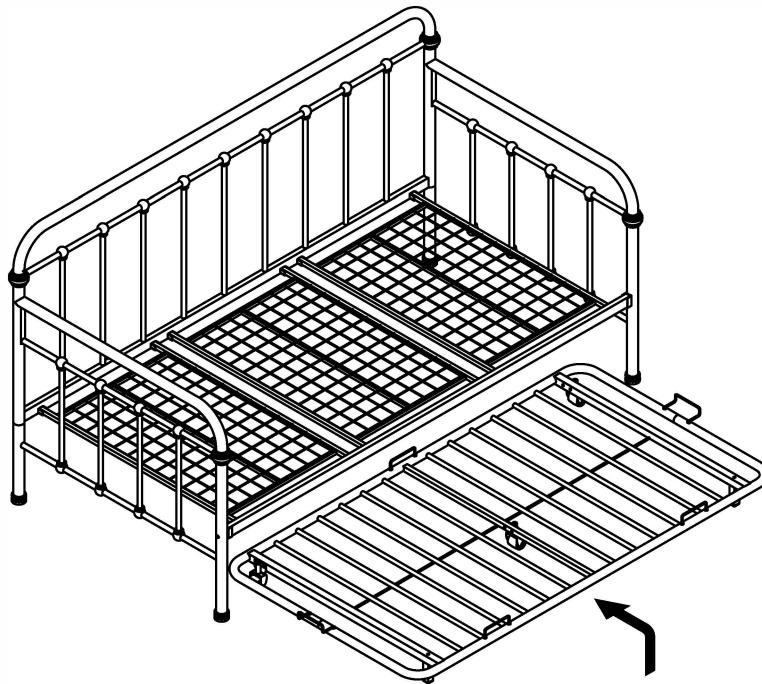

STEP 10: Completed.

